

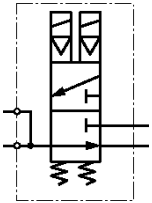

XSz Safety valves

Fail-safe double valves

3/2, G $\frac{1}{4}$ to G2



Inherently fail-safe without residual pressure

Dynamic self monitoring

Double valve control system

For use with pneumatic clutch and brake systems and other 3-way safety functions

Poppet design with feedback signal ports

Fast exhaust capability

Conforms to EN 692, BG, OSHA, SUWA and other approvals

Improves safety and reduces downtime on mechanical power press applications

Quick and easy adjustment of 'overlap' on mechanical presses

No additional electrical monitoring required

Easily fitted into existing systems

Technical data

Medium:

Compressed air, filtered, lubricated and non-lubricated

Operating pressure:

Size 8: 3 to 10 bar

Size 10: 2 to 10 bar

Size 20/32/50: 2 to 8 bar

Ambient temperature:

-10°C to +60°C

Consult our Technical Service for use below +2°C.

Materials

Body: aluminium

Seals: polyurethane and NBR

For full details of our press ancillary equipment please contact our Technical Service.

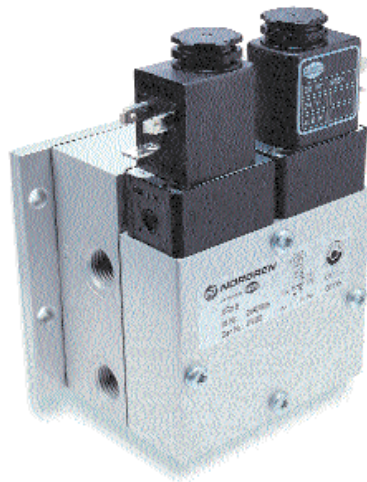

XSz 8

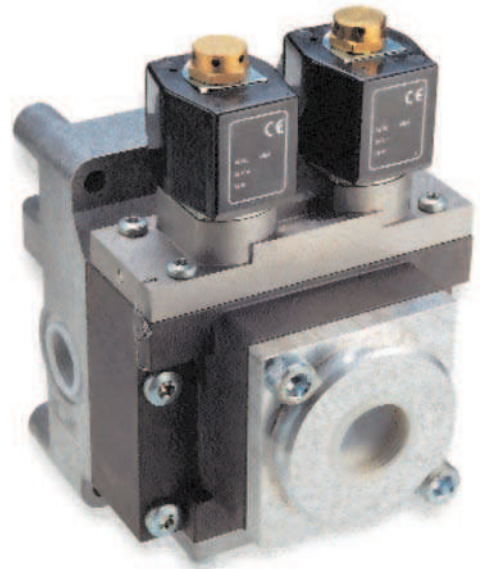

XSz 20

Type	Voltage	Port size				Model G-thread
		P	A	A1	R	
XSz 8*	d.c./a.c.	1/4"	1/4"	–	1/4"	24928063052****
XSz 10**	a.c.	1/2"	1/2"	(1/2")	3/4"	24929000200****
XSz 10**	d.c.	1/2"	1/2"	(1/2")	3/4"	24929010200****
XSz 20**	d.c./a.c.	1/2"	3/4"	(1")	1"	24930000800****
XSz 20**	d.c./a.c.	3/4"	3/4"	(1")	1"	24930400800****
XSz 20**	d.c./a.c.	3/4"	(3/4")	1"	1"	24930420800****
XSz 32	d.c./a.c.	1"	1"	–	1 1/2"	24931300800****
XSz 32	d.c./a.c.	1"	1"	1 1/2"	1 1/2"	24931340800****
XSz 50	d.c./a.c.	1 1/2"	2"	–	2"	24932300800****

**** Insert voltage codes from table below.

Port sizes in brackets are plugged.

Supplied without plug. If required, select model 0570275, see page 384

* Silencer enclosed ** Valve with integrated silencer available

Voltage codes

Voltage	Code
24 V d.c.	02400
24 V a.c.	02450
110 V a.c.	11050
230 V a.c.	23050

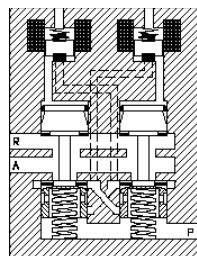

Neutral position

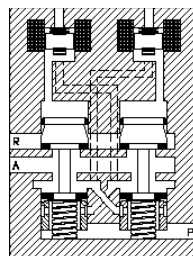

Activator position

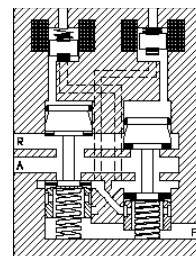

Malfunction position

P = Air pressure port. A = Power port (clutch / brake). R = Exhaust

XSz Safety valves

Fail-safe double valves

3/2, G $\frac{1}{4}$ to G2

XSz 8

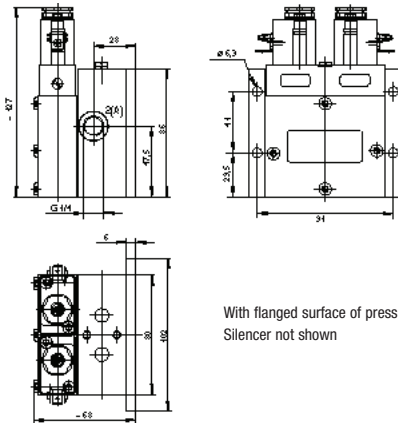

With flanged surface of pressure switch and failure indication element.
Silencer not shown

XSz 10

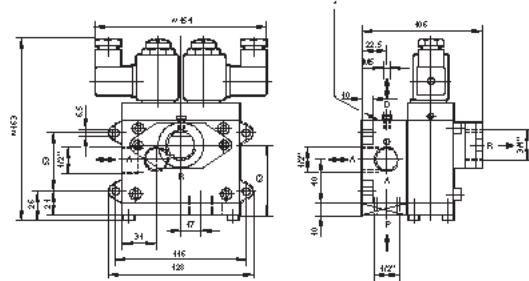

*Flanged surface of pressure switch and failure indication element.
Silencer not shown

XSz 20

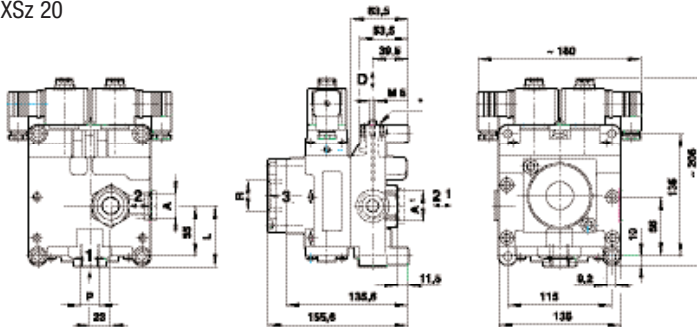

* Flange surface for failure indication element and flange surface for pressure balance.
Silencer not shown

XSz 32

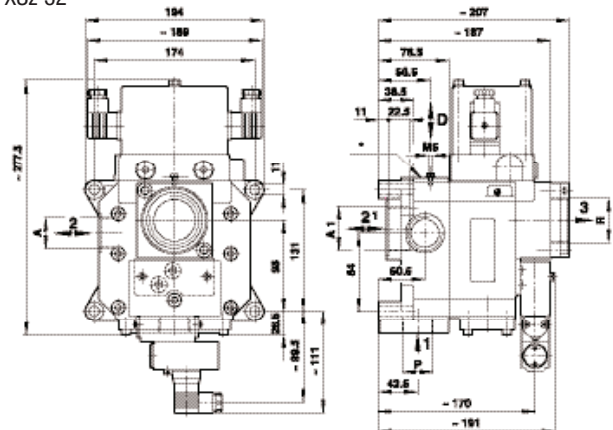

* Flange surface for failure indication element and flange surface for pressure balance.
Silencer not shown

XSz 50

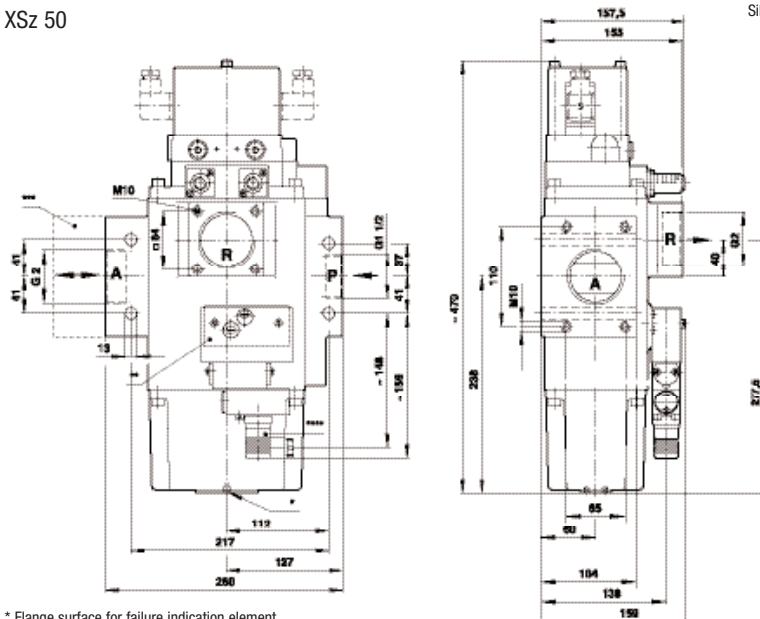

* Flange surface for failure indication element
** Flange surface for pressure balance
*** Flange surface for 18D pressure switch. Adapter flange, type 0545005
**** Piston manometer