



Twin rod cylinder Double acting/standard

STR2-^M/_B Series

● Bore size: φ6/φ10/φ16/φ20/φ25/φ32

JIS symbol



LCW
LCR
LCG
LCX
LCM
STM
STG
STS/STL

STR2

UCA2

ULK*

JSK/M2

JSG

JSC3/JSC4

USSD

UFCD

USC

JSB3

LMB

LML

HCM

HCA

LBC

CAC4

UCAC2

CAC-N

UCAC-N

RCC2

RCS

PCC

SHC

MCP

GLC

MFC

BBS

RRC

GRC

RV3*

NHS

HR

LN

Hand

Chuk

MecHnd/Chuk

ShkAbs

FJ

FK

SpdContr

Ending

Specifications

Descriptions		STR2-M (metal bush bearing)			STR2-B (ball bearing)		
Bore size	mm	φ6	φ10	φ16	φ20	φ25	φ32
Actuation		Double acting					
Working fluid		Compressed air					
Max. working pressure	MPa	0.7 (≈100 psi, 7 bar)					
Min. working pressure	MPa	0.2 (≈29 psi, 2 bar)	0.15 (≈22 psi, 1.5 bar)	0.1 (≈15 psi, 1 bar)			
Proof pressure	MPa	1.05 (≈150 psi, 10.5 bar)					
Ambient temperature	°C	-10 (14°F) to 60 (140°F) (no freezing)					
Port size		M5					Rc1/8
Stroke tolerance	mm	+2.0					
		0					
Adjustable stroke range	mm	0 to -5					
Working piston speed	mm/s	50 to 500					
Non-rotating accuracy	STR2-M	±0.4°	±0.3°			±0.2°	
(reference value)	STR2-B	±0.2°	±0.1°			±0.3°	
Piston rod	STR2-M	Metal bush bearing					
Bearing	STR2-B	Ball bearing					
Cushion		Rubber cushion					
Lubrication		Not required (use turbine oil class 1 ISO VG32 if necessary for lubrication)					
Max absorbed energy	PUSH	0.008	0.061	0.181	0.303	0.68	1.3
	PULL	0.059	0.083	0.083	0.127	0.237	0.311

Stroke length

Bore size	Stroke length (mm)	Max. stroke length (mm)	Min. stroke length (mm)	Min. stroke with switch (mm)
φ6	10, 20, 30, 40, 50	50	5	10
φ10				
φ16	10, 20, 30, 40, 50 60, 70, 80, 90, 100	100		
φ20				
φ25				
φ32				

*1 : In the case of rear piping:

- φ16: 70
- φ20/φ25: 60
- φ32: 50

*2 : Custom stroke length

Available in 1mm increments.
However, the total length is the same as that of the next longer standard stroke length.

Theoretical thrust table

(Unit: N)

Bore size (mm)	Operating direction	Working pressure MPa							
		0.1	0.15	0.2	0.3	0.4	0.5	0.6	0.7
φ6	Push	-	-	11.3	17.0	22.6	28.3	33.9	39.6
	Pull	-	-	6.28	9.42	12.6	15.7	18.8	22.0
φ10	Push	-	-	31.4	47.1	62.8	78.5	94.2	1.10×10 ²
	Pull	-	-	20.1	30.2	40.2	50.3	60.3	70.4
φ16	Push	40.2	60.3	80.4	1.21×10 ²	1.61×10 ²	2.01×10 ²	2.41×10 ²	2.81×10 ²
	Pull	24.5	36.8	49.0	73.5	98.0	1.23×10 ²	1.47×10 ²	1.72×10 ²
φ20	Push	62.8	94.2	1.26×10 ²	1.88×10 ²	2.51×10 ²	3.14×10 ²	3.77×10 ²	4.40×10 ²
	Pull	40.2	60.3	80.4	1.21×10 ²	1.61×10 ²	2.01×10 ²	2.41×10 ²	2.81×10 ²
φ25	Push	98.2	1.47×10 ²	1.96×10 ²	2.95×10 ²	3.93×10 ²	4.91×10 ²	5.89×10 ²	6.87×10 ²
	Pull	67.4	1.01×10 ²	1.35×10 ²	2.02×10 ²	2.70×10 ²	3.37×10 ²	4.04×10 ²	4.72×10 ²
φ32	Push	1.61×10 ²	2.41×10 ²	3.22×10 ²	4.83×10 ²	6.43×10 ²	8.04×10 ²	9.65×10 ²	1.13×10 ³
	Pull	1.21×10 ²	1.81×10 ²	2.41×10 ²	3.62×10 ²	4.83×10 ²	6.03×10 ²	7.24×10 ²	8.44×10 ²

Switch specifications

- 1-color/2-color display

Descriptions	Proximity 2-wire		Proximity 3-wire			Reed 2-wire				
	K2H/K2V	K2YH/K2YV	K3H/K3V	K3PH/K3PV (Custom order)	K3YH/K3YV	K0H/K0V		K5H/K5V		
Applications	Dedicated for programmable controller		For programmable controller, relay			For programmable controller, relay		For programmable controller, relay, IC circuit (no indicator lamp), serial connection		
Output method	-		NPN output	PNP output	NPN output	-				
Power supply voltage	-		10 to 28 VDC			-				
Load voltage	10 to 30 VDC		30 VDC or less			12 VDC/24 VDC	110 VAC	5/12/24 VDC	110 VAC	
Load current	5 to 20 mA (*1)		50 mA or less			5 to 50 mA	7 to 20 mA	50 mA or less	20 mA or less	
Indicator lamp	LED (Lit when ON)	Red/green LED (Lit when ON)	LED (Lit when ON)	Yellow LED (Lit when ON)	Red/green LED (Lit when ON)	LED (Lit when ON)		-		
Leakage current	1 mA or less		10 μA or less			0 mA				
Weight	g	1 m:18 3 m:49 5 m:80	1 m:31 3 m:85 5 m:139	1 m:18 3 m:49 5 m:80	1 m:31 3 m:85 5 m:139	1 m:18 3 m:49 5 m:80				

*1 : The above max. load current is 20 mA at 25°C. The current is lower than 20 mA if operating ambient temperature around the switch is higher than 25°C. (5 to 10 mA at 60°C)

*2 : Refer to Ending Page 1 for other switch specifications.

*3 : Dimensions depend on switch model No. Refer to Ending Page 21 for details.

Cylinder weight

Unit: g

Bore size	Product weight at 0 mm stroke		Additional weight per S = 10 mm
	STR2-M	STR2-B	
φ6	60	64	10
φ10	140	155	14
φ16	240	300	20
φ20	340	405	40
φ25	580	610	52
φ32	1300	1150	83

(Example) Product weight

STR2-M-6-10-K2H-D

- Product weight for 0 mm stroke length ... 60 g
- Additional weight for stroke length 10 mm ... 10 g x 1 = 10 g
- Weight of 2 cylinder switches ... 18 g x 2 = 36 g
- Product weight ... 60 g + 10 g + 36 g = 106 g

Clean-room specifications (Catalog No. CB-033SA)

- Anti-dust generation structure for use in cleanrooms

STR2-B-.....-P7*

STR2-B-.....-P5*

Specifications for rechargeable battery (Catalog No. CC-1226A)

- Design compatible with rechargeable battery manufacturing process.

STR2-M-B-.....-P4*

LCW
LCR
LCG
LCX
LCM
STM
STG
STS/STL
STR2
UCA2
ULK*
JSK/M2
JSG
JSC3/JSC4
USSD
UFCD
USC
JSB3
LMB
LML
HCM
HCA
LBC
CAC4
UCAC2
CAC-N
UCAC-N
RCC2
RCS
PCC
SHC
MCP
GLC
MFC
BBS
RRC
GRC
RV3*
NHS
HR
LN
Hand
Chuk
MecHnd/Chuk
ShkAbs
FJ
FK
SpdContr
Ending

STR2-M B Series

How to order

Without switch (built-in magnet for switch)

STR2 - M - 16 - 30 - F

With switch (built-in magnet for switch)

STR2 - M - 16 - 30 - K0H - R - F

Model No.

A Bearing

B Bore size

C Port thread

D Stroke length

*1

■ The custom stroke length is available in 1 mm increments.

E Switch model No.

*2

F Switch quantity

G Option

*3

*4

⚠ Precautions for model No. selection

*1 : The max stroke length of rear piping "R" is:

- φ6/10 : 50 Stroke
- φ16 : 70 Stroke
- φ20/25 : 60 Stroke
- φ32 : 50 Stroke

*2 : STR2-B-6 and 10 are not compatible with a reed switch.

*3 : The ball bearing is copper and PTFE free "P6" standard.

*4 : The piping port positions for "O" are as shown in the figure below.

Piping port positions for standard (blank)

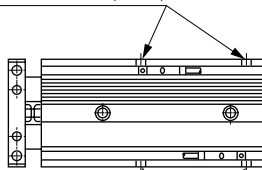

Piping port position on the 180° opposite side (Code: O) piping port

*5 : In the case of G thread, ports on the opposite side (option "O") are not available. Rather than plug sealing, they are simply not provided.
(The standard ports are not provided in the case of option "O".)

Code	Content					
A Bearing						
M	Metal bush bearing					
B	Ball bearing					
B Bore size (mm)						
6	φ6					
10	φ10					
16	φ16					
20	φ20					
25	φ25					
32	φ32					
C Port thread						
Blank	Rc thread					
NN	NPT thread (φ32 only) (custom order product)					
GN	G thread (φ32 only) (custom order product) *5					
D Stroke length (mm)						
Bore size	Stroke length	Custom stroke length				
φ6	5 to 50	In 1 mm increments				
φ10	5 to 50					
φ16	5 to 100					
φ20	5 to 100					
φ25	5 to 100					
φ32	5 to 100					
E Switch model No.						
Axial lead wire	Radial lead wire	Contact	Voltage		Indicator	Lead wire
			AC	DC		
K0H*	K0V*	Reed	●	●	1-color display	2-wire
K5H*	K5V*		●	●	no indicator lamp	
K2H*	K2V*	Proximity		●	1-color display	2-wire
K3H*	K3V*			●	1-color display (custom)	3-wire
K3PH*	K3PV*			●		
K2YH*	K2YV*			●	2-color display	2-wire
K3YH*	K3YV*			●	2-color display	3-wire
* Lead wire length						
Blank	1 m (standard)					
3	3 m (option)					
5	5 m (option)					
F Switch quantity						
R	1 on rod side					
H	1 on head side					
D	2					
G Option						
F	End plate material: steel					
P6	Copper and PTFE free					
O	Piping port position on the 180° opposite side					
R	Rear piping					

[Example of model No.]

STR2-M-16-30-K0H-R-F

Model: Twin rod cylinder, standard

- A** Bearing : Metal bush bearing
- B** Bore size : φ16 mm
- C** Port thread : Rc thread
- D** Stroke length : 30 mm
- E** Switch model No.: Reed K0H switch
- F** Switch quantity : 1 on rod side
- G** Option : End plate material: steel

How to order switch

SW - K0H*

Switch model No.
(Item **E** above)

MEMO

LCW
LCR
LCG
LCX
LCM
STM
STG
STS/STL
STR2
UCA2
ULK*
JSK/M2
JSG
JSC3/JSC4
USSD
UFCD
USC
JSB3
LMB
LML
HCM
HCA
LBC
CAC4
UCAC2
CAC-N
UCAC-N
RCC2
RCS
PCC
SHC
MCP
GLC
MFC
BBS
RRC
GRC
RV3*
NHS
HR
LN
Hand
Chuk
MecHnd/Chuk
ShkAbs
FJ
FK
SpdContr
Ending

STR2-M Series

- LCW
- LCR
- LCG
- LCX
- LCM
- STM
- STG
- STS/STL
- STR2**
- UCA2
- ULK*
- JSK/M2
- JSG
- JSC3/JSC4
- USSD
- UFCD
- USC
- JSB3
- LMB
- LML
- HCM
- HCA
- LBC
- CAC4
- UCAC2
- CAC-N
- UCAC-N
- RCC2
- RCS
- PCC
- SHC
- MCP
- GLC
- MFC
- BBS
- RRC
- GRC
- RV3*
- NHS
- HR
- LN
- Hand
- Chuk
- MecHnd/Chuk
- ShkAbs
- FJ
- FK
- SpdContr
- Ending

Internal structure and parts list (metal bush bearing φ6/φ10)

- Standard
STR2-M
- End plate material: steel
STR2-M-F
- Copper and PTFE free
STR2-M-P6
- Piping port position on the 180° opposite side
STR2-M ... -O

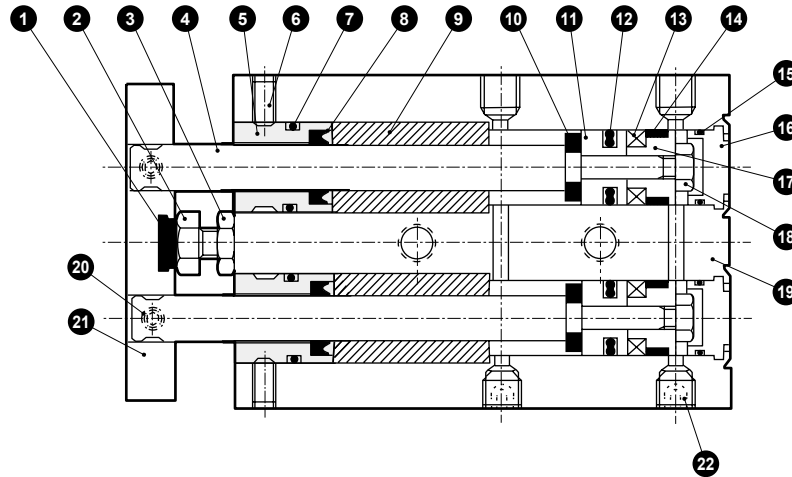

No.	Part name	Material	Remarks	No.	Part name	Material	Remarks
1	Cushion rubber (H)	Urethane rubber		12	Piston packing	Nitrile rubber	
2	Hexagon head bolt	Stainless steel		13	Magnet	Plastic	
3	Hexagon nut	Stainless steel		14	Wear ring	Acetal resin	
4	Piston rod	Stainless steel		15	O-ring	Nitrile rubber	
5	Housing	Stainless steel		16	Cap	Aluminum alloy	Chromate
6	Hexagon socket set screw	Stainless steel		17	Spacer	Aluminum alloy	Chromate
7	O-ring	Nitrile rubber		18	Hexagon nut	Steel	Zinc chromate
8	Rod packing	Nitrile rubber		19	Cylinder body	Aluminum alloy	Hard alumite
9	Bush *1	Copper alloy		20	Hexagon socket set screw	Stainless steel	
10	Cushion rubber (R)	Urethane rubber		21	End plate *2	Aluminum alloy	Alumite
11	Piston	Aluminum alloy	Chromate	22	Hexagon socket set screw	Stainless steel	

*1 : Cast iron oil-impregnated bearing for copper and PTFE free.

*2 : The steel end plate is zinc chromate.

Repair parts list

STR2-M (standard), STR2-M-F (end plate material: steel), STR2-M-P6 (copper and PTFE free)

Bore size (mm)	Kit No.	Repair parts No.
φ6	STR2-6K	1 7 8 10 12 14
φ10	STR2-10K	

Note : Specify the kit No. when placing an order.

Internal structure and parts list (metal bush bearing $\phi 16/\phi 20/\phi 25/\phi 32$)

- Standard
STR2-M
- End plate material: steel
STR2-M-F
- Copper and PTFE free
STR2-M-P6
- Piping port position on the 180° opposite side
STR2-M ... -O

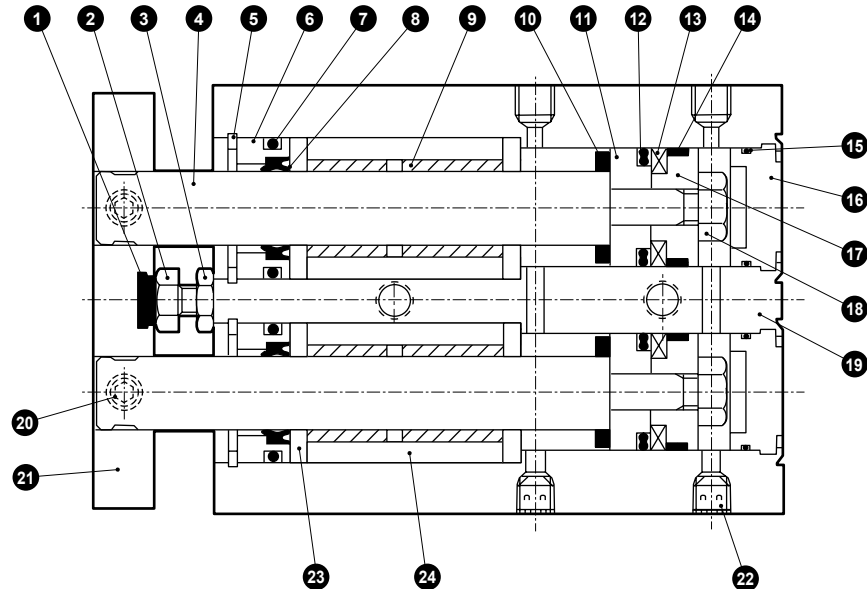

No.	Part name	Material	Remarks	No.	Part name	Material	Remarks
1	Cushion rubber (H)	Urethane rubber		13	Magnet	Plastic	
2	Hexagon head bolt	Stainless steel		14	Wear ring	Acetal resin	
3	Hexagon nut	Stainless steel		15	O-ring	Nitrile rubber	
4	Piston rod	Stainless steel ($\phi 16, \phi 20$) Steel ($\phi 25, \phi 32$)	Industrial chrome plating	16	Cap	Aluminum alloy	Chromate
5	Snap ring for hole	Stainless steel		17	Spacer	Aluminum alloy	Chromate
6	Housing	Aluminum alloy	Chromate	18	Hexagon nut	Steel	Zinc chromate
7	O-ring	Nitrile rubber		19	Cylinder body	Aluminum alloy	Hard alumite
8	Rod packing	Nitrile rubber		20	Hexagon socket set screw	Stainless steel	
9	Bush *1	Copper alloy		21	End plate *2	Aluminum alloy	Alumite
10	Cushion rubber (R)	Urethane rubber		22	Hexagon socket set screw	Stainless steel	
11	Piston	Aluminum alloy	Chromate	23	Spacer	Aluminum alloy	Chromate
12	Piston packing	Nitrile rubber		24	Aluminum housing	Aluminum alloy	Chromate

*1 : Cast iron oil-impregnated bearing for copper and PTFE free.

*2 : The steel end plate is zinc chromate.

Repair parts list

STR2-M (standard), STR2-M-F (end plate material: steel), STR2-M-P6 (copper and PTFE free)

Bore size (mm)	Kit No.	Repair parts No.
$\phi 16$	STR2-16K	
$\phi 20$	STR2-20K	1 7 8
$\phi 25$	STR2-25K	10 12 14
$\phi 32$	STR2-32K	

Note : Specify the kit No. when placing an order.

LCW
LCR
LCG
LCX
LCM
STM
STG
STS/STL
STR2
UCA2
ULK*
JSK/M2
JSG
JSC3/JSC4
USSD
UFCD
USC
JSB3
LMB
LML
HCM
HCA
LBC
CAC4
UCAC2
CAC-N
UCAC-N
RCC2
RCS
PCC
SHC
MCP
GLC
MFC
BBS
RRC
GRC
RV3*
NHS
HR
LN
Hand
Chuk
MecHnd/Chuk
ShkAbs
FJ
FK
SpdContr
Ending

STR2-M-R Series

Internal structure and parts list (metal bush bearing $\phi 6/\phi 10/\phi 16/\phi 20/\phi 25/\phi 32$)

● Rear piping STR2-M-R $\phi 6, \phi 10$

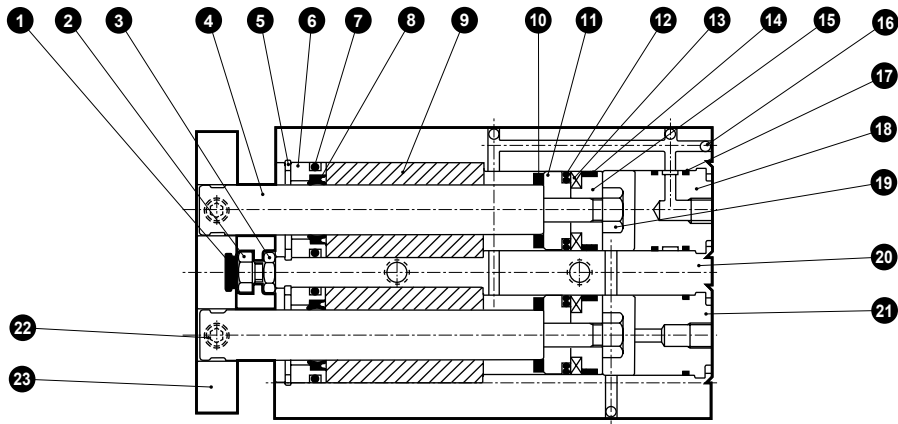

$\phi 16$ to $\phi 32$

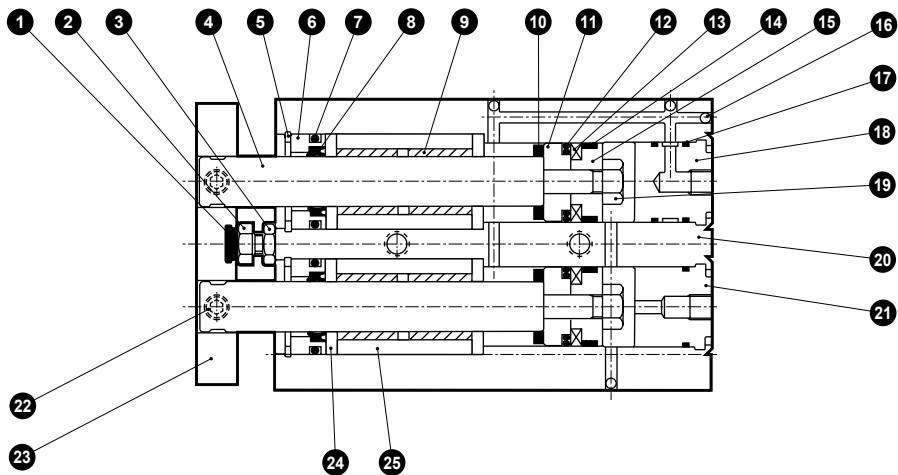

No.	Part name	Material	Remarks	No.	Part name	Material	Remarks
1	Cushion rubber (H)	Urethane rubber		13	Magnet	Plastic	
2	Hexagon head bolt	Stainless steel		14	Wear ring	Acetal resin	
3	Hexagon nut	Stainless steel		15	Spacer	Aluminum alloy	Chromate
4	Piston rod	Stainless steel ($\phi 6$ to $\phi 20$) Steel ($\phi 25, \phi 32$)	Industrial chrome plating ($\phi 16$ to $\phi 32$)	16	Steel ball	Steel	
5	Snap ring for hole	Stainless steel		17	O-ring	Nitrile rubber	
6	Housing	Stainless steel ($\phi 6, \phi 10$) Aluminum alloy ($\phi 16$ to $\phi 32$)	Chromate	18	Cap (A)	Aluminum alloy	Chromate
7	O-ring	Nitrile rubber		19	Hexagon nut	Steel	Zinc chromate
8	Rod packing	Nitrile rubber		20	Cylinder body	Aluminum alloy	Hard alumite
9	Bush	Copper alloy		21	Cap (B)	Aluminum alloy	Chromate
10	Cushion rubber (R)	Urethane rubber		22	Hexagon socket set screw	Stainless steel	
11	Piston	Aluminum alloy	Chromate	23	End plate	Aluminum alloy	Alumite
12	Piston packing	Nitrile rubber		24	Spacer	Aluminum alloy	Chromate
				25	Aluminum housing	Aluminum alloy	Chromate

Repair parts list

STR2-M-R (rear piping)

Bore size (mm)	Kit No.	Repair parts No.
$\phi 6$	STR2-6K	
$\phi 10$	STR2-10K	
$\phi 16$	STR2-16K	1 7 8
$\phi 20$	STR2-20K	10 12 14
$\phi 25$	STR2-25K	
$\phi 32$	STR2-32K	

Note : Specify the kit No. when placing an order.

Internal structure and parts list (ball bearing $\phi 6/\phi 10$)

- Standard
STR2-B
- End plate material: steel
STR2-B-F
- Piping port position on the 180° opposite side
STR2-B ... -O

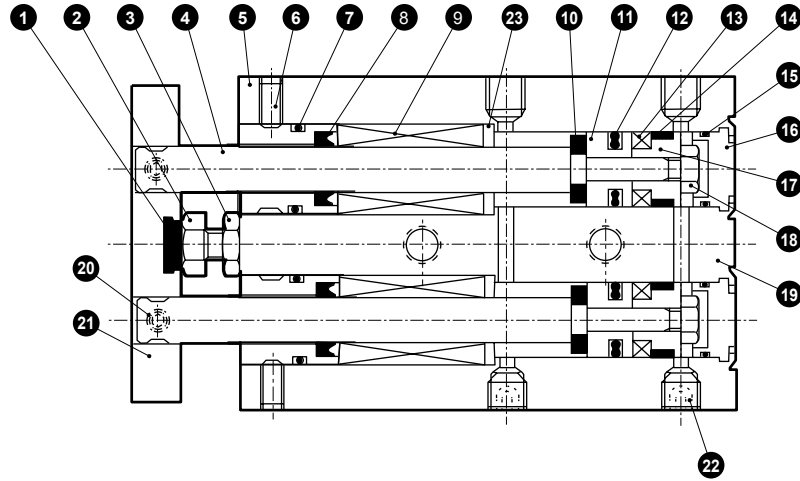

No.	Part name	Material	Remarks	No.	Part name	Material	Remarks
1	Cushion rubber (H)	Urethane rubber		13	Magnet	Plastic	
2	Hexagon head bolt	Stainless steel		14	Wear ring	Acetal resin	
3	Hexagon nut	Stainless steel		15	O-ring	Nitrile rubber	
4	Piston rod	Steel	Industrial chrome plating	16	Cap	Aluminum alloy	Chromate
5	Housing	Stainless steel		17	Spacer	Aluminum alloy	Chromate
6	Hexagon socket set screw	Stainless steel		18	Hexagon nut	Steel	Zinc chromate
7	O-ring	Nitrile rubber		19	Cylinder body	Aluminum alloy	Hard alumite
8	Rod packing	Nitrile rubber		20	Hexagon socket set screw	Stainless steel	
9	Bearing			21	End plate *1	Aluminum alloy	Alumite
10	Cushion rubber (R)	Urethane rubber		22	Hexagon socket set screw	Stainless steel	
11	Piston	Aluminum alloy	Chromate	23	Spacer	Aluminum alloy	Chromate
12	Piston packing	Nitrile rubber					

*1 : The steel end plate is zinc chromate.

Repair parts list

STR2-B (standard), STR2-B-F (end plate material: steel)

Bore size (mm)	Kit No.	Repair parts No.
$\phi 6$	STR2-6K	1 7 8 10 12 14
$\phi 10$	STR2-10K	

Note : Specify the kit No. when placing an order.

LCW
LCR
LCG
LCX
LCM
STM
STG
STS/STL
STR2
UCA2
ULK*
JSK/M2
JSG
JSC3/JSC4
USSD
UFCD
USC
JSB3
LMB
LML
HCM
HCA
LBC
CAC4
UCAC2
CAC-N
UCAC-N
RCC2
RCS
PCC
SHC
MCP
GLC
MFC
BBS
RRC
GRC
RV3*
NHS
HR
LN
Hand
Chuk
MecHnd/Chuk
ShkAbs
FJ
FK
SpdContr
Ending

STR2-B Series

LCW
LCR
LCG
LCX
LCM
STM
STG
STS/STL
STR2
UCA2
ULK*
JSK/M2
JSG
JSC3/JSC4
USSD
UFCD
USC
JSB3
LMB
LML
HCM
HCA
LBC
CAC4
UCAC2
CAC-N
UCAC-N
RCC2
RCS
PCC
SHC
MCP
GLC
MFC
BBS
RRC
GRC
RV3*
NHS
HR
LN
Hand
Chuk
MecHnd/Chuk
ShkAbs
FJ
FK
SpdContr
Ending

Internal structure and parts list (ball bearing $\phi 16/\phi 20/\phi 25/\phi 32$)

- Standard
STR2-B
- End plate material: steel
STR2-B-F
- Piping port position on the 180° opposite side
STR2-B ... -O

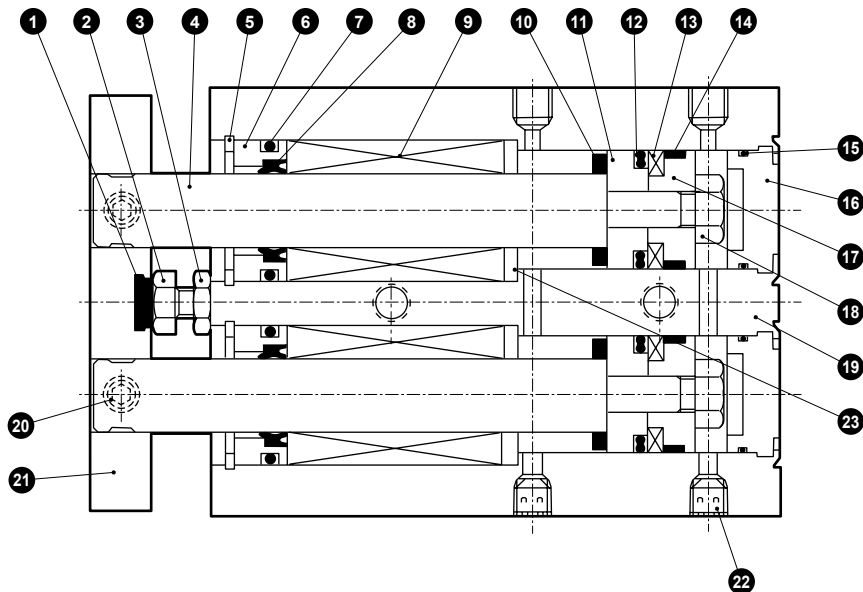

No.	Part name	Material	Remarks	No.	Part name	Material	Remarks
1	Cushion rubber (H)	Urethane rubber		13	Magnet	Plastic	
2	Hexagon head bolt	Stainless steel		14	Wear ring	Acetal resin	
3	Hexagon nut	Stainless steel		15	O-ring	Nitrile rubber	
4	Piston rod	Steel	Industrial chrome plating	16	Cap	Aluminum alloy	Chromate
5	Snap ring for hole	Stainless steel		17	Spacer	Aluminum alloy	Chromate
6	Housing	Aluminum alloy	Chromate	18	Hexagon nut	Steel	Zinc chromate
7	O-ring	Nitrile rubber		19	Cylinder body	Aluminum alloy	Hard alumite
8	Rod packing	Nitrile rubber		20	Hexagon socket set screw	Stainless steel	
9	Bearing			21	End plate *1	Aluminum alloy	Alumite
10	Cushion rubber (R)	Urethane rubber		22	Hexagon socket set screw	Stainless steel	
11	Piston	Aluminum alloy	Chromate	23	Spacer	Aluminum alloy	Chromate
12	Piston packing	Nitrile rubber					

*1 : The steel end plate is zinc chromate.

Repair parts list

STR2-B (standard), STR2-B-F (end plate material: steel)

Bore size (mm)	Kit No.	Repair parts No.
$\phi 16$	STR2-16K	
$\phi 20$	STR2-20K	1 7 8
$\phi 25$	STR2-25K	10 12 14
$\phi 32$	STR2-32K	

Internal structure and parts list (ball bearing)

● Rear piping
STR2-B-R

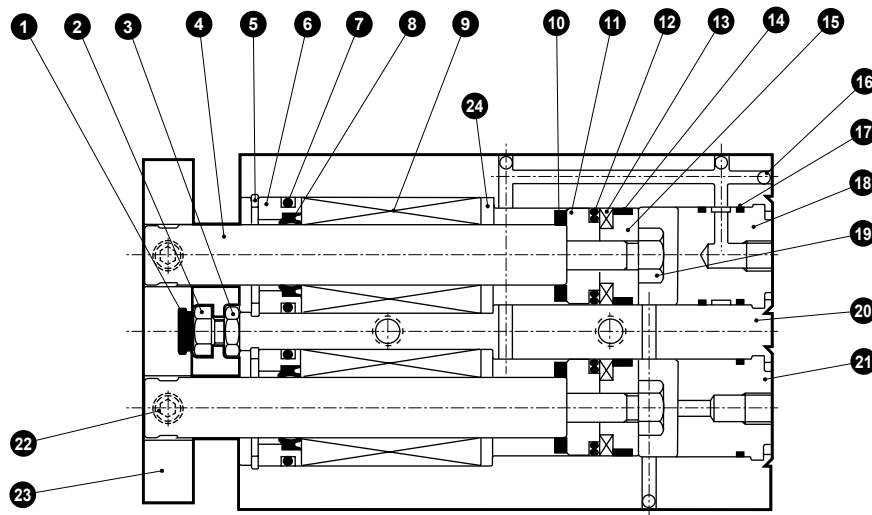

LCW
LCR
LCG
LCX
LCM
STM
STG
STS/STL
STR2
UCA2
ULK*
JSK/M2
JSG
JSC3/JSC4
USSD
UFCD
USC
JSB3
LMB
LML
HCM
HCA
LBC
CAC4
UCAC2
CAC-N
UCAC-N
RCC2
RCS
PCC
SHC
MCP
GLC
MFC
BBS
RRC
GRC
RV3*
NHS
HR
LN
Hand
Chuk
MecHnd/Chuk
ShkAbs
FJ
FK
SpdContr
Ending

No.	Part name	Material	Remarks	No.	Part name	Material	Remarks
1	Cushion rubber (H)	Urethane rubber		13	Magnet	Plastic	
2	Hexagon head bolt	Stainless steel		14	Wear ring	Acetal resin	
3	Hexagon nut	Stainless steel		15	Spacer	Aluminum alloy	Chromate
4	Piston rod	Steel	Industrial chrome plating	16	Steel ball	Steel	
5	Snap ring for hole	Stainless steel		17	O-ring	Nitrile rubber	
6	Housing	Stainless steel (φ6, φ10) Aluminum alloy (φ16 to φ32)	Chromate	18	Cap (A)	Aluminum alloy	Chromate
7	O-ring	Nitrile rubber		19	Hexagon nut	Steel	Zinc chromate
8	Rod packing	Nitrile rubber		20	Cylinder body	Aluminum alloy	Hard alumite
9	Bearing			21	Cap (B)	Aluminum alloy	Chromate
10	Cushion rubber (R)	Urethane rubber		22	Hexagon socket set screw	Stainless steel	
11	Piston	Aluminum alloy	Chromate	23	End plate	Aluminum alloy	Alumite
12	Piston packing	Nitrile rubber		24	Spacer	Aluminum alloy	Chromate

Repair parts list

STR2-B-R (rear piping)

Bore size (mm)	Kit No.	Repair parts No.
φ 6	STR2-6K	
φ10	STR2-10K	
φ16	STR2-16K	1 7 8
φ20	STR2-20K	10 12 14
φ25	STR2-25K	
φ32	STR2-32K	

Note : Specify the kit No. when placing an order.



Dimensions (φ6 to φ32)

● Standard, end plate material: steel (F), copper and PTFE free (P6), piping port position on the 180° opposite side (O)

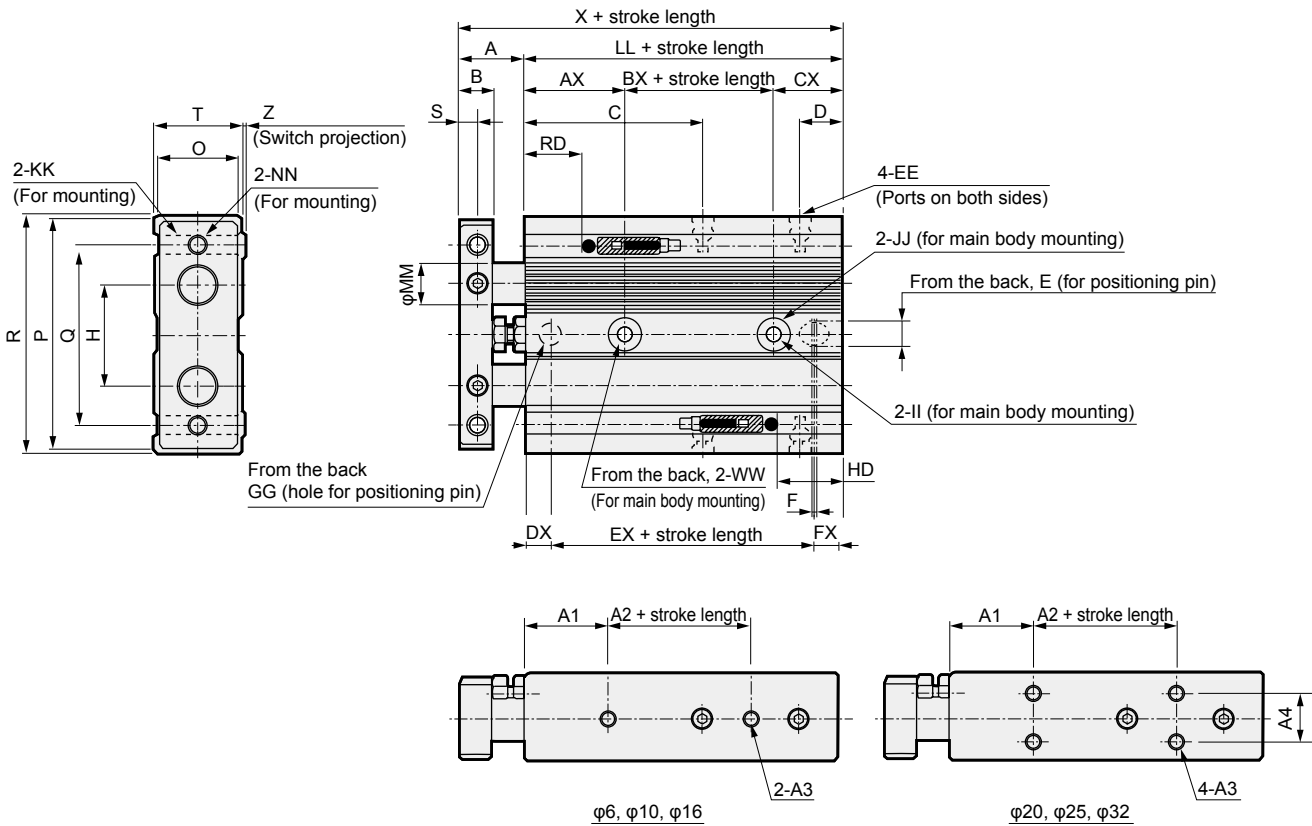

*1 : HD and RD dimensions for 10 mm stroke length differ from these dimensions according to the setting.
 *2 : When using a custom stroke length, the total length is the same as that of the next longer standard stroke length.
 *3 : Refer to page 610 for HD, RD and protruding dimensions of the 2-color display switch.

Code	Basic, O, F and P6 basic dimensions																
Bore size (mm)	A	B	C	D	E	EE	F	GG	H	II	JJ	KK	LL	MM	NN	O	P
φ 6	12	6	24.5	7.5	4 ^{+0.07} _{-0.02} depth 4	M5	1	4 ^{+0.07} _{-0.02} depth 4	14	3.4	6.5 spot face depth 3.3	M3 through	44	4	M3 through	11	34
φ10	14	6	35	7	4 ^{+0.07} _{-0.02} depth 4	M5	1	4 ^{+0.07} _{-0.02} depth 4	20	4.3	8 spot face depth 4.4	M4 through	55	6	M4 through	13	42
φ16	16	8	43	9.5	6 ^{+0.07} _{-0.02} depth 6	M5	1	6 ^{+0.07} _{-0.02} depth 6	25	4.3	8 spot face depth 4.4	M5 through	66	10	M5 through	19	52
φ20	20	10	46	9.5	6 ^{+0.07} _{-0.02} depth 6	M5	1	6 ^{+0.07} _{-0.02} depth 6	28	5.2	9.5 spot face depth 5.4	M5 through	75	12	M5 through	24	60
φ25	22	12	44	10.5	6 ^{+0.07} _{-0.02} depth 6	M5	1	6 ^{+0.07} _{-0.02} depth 6	34	6.3	11 spot face depth 6.5	M6 through	75	14	M6 through	30	70
φ32	22	12	56	11	6 ^{+0.07} _{-0.02} depth 6	Rc1/8	1	6 ^{+0.07} _{-0.02} depth 6	44	6.3	11 spot face depth 6.5	M6 through	91	16	M6 through	36	94

Code																	K0/K5/K2/K3		
Bore size (mm)	Q	R	S	T	WW	X	AX	BX	CX	DX	EX	FX	Z	A1	A2	A3	A4	HD	RD
φ 6	29	36	3	13	M4 depth 5	56	20	10	14	7	30	7	1.0	15	10	M3 depth 4	-	3.5 *1	21 *1
φ10	36	44	3	15	M5 depth 6	69	24	14	17	8	38	9	1.0	15	20	M3 depth 3.5	-	2.5 *1	33 *1
φ16	45	58	4	21	M5 depth 6	82	24	26	16	8	50	8	0.5	20	25	M4 depth 4	-	7	39.5
φ20	50	62	5	27	M6 depth 8	95	24	33	18	9	57	9	0.5	20	30	M4 depth 4	13	10.5	45
φ25	60	72	6	33	M8 depth 8	97	24	33	18	9	57	9	0.5	20	30	M5 depth 6	18	11.5	43.5
φ32	75	96	6	38	M8 depth 8	113	24	47	20	9	73	9	0.5	20	40	M5 depth 8	24	15.5	55.5

*4 : STR2-B-6 and 10 are not compatible with K0 and K5 reed switches.
 *5 : The cylinder may tilt due to the uneven surface if it is installed with the spot face side (JJ) contacted. In this case, change the port position or use the option of piping port position on the 180° opposite side (O) to keep the spot face side from being the contacting surface.

Dimensions (φ6 to φ32)



● Rear piping (R)

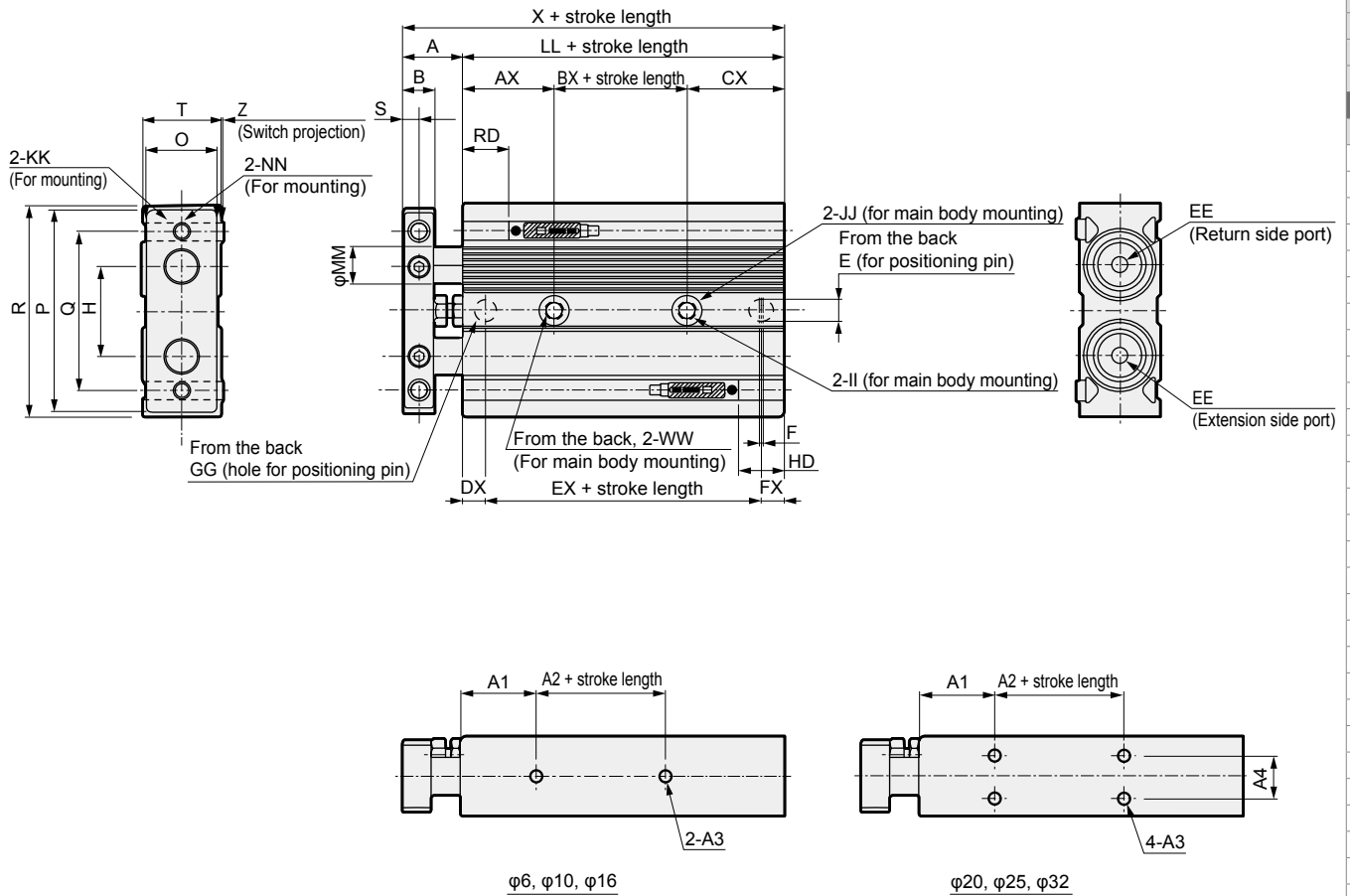

- *1 : HD and RD dimensions for 10 mm stroke length differ from these dimensions according to the setting.
- *2 : When using a custom stroke length, the total length is the same as that of the next longer standard stroke length.
- *3 : Refer to page 610 for HD, RD and protruding dimensions of the 2-color display switch.

Code	R Basic dimensions																
Bore size (mm)	A	B	E	EE	F	GG	H	II	JJ	KK	LL	MM	NN	O	P		
φ 6	12	6	4 ^{+0.07} _{-0.02} depth 4	M5	1	4 ^{+0.07} _{-0.02} depth 4	14	3.4	6.5 spot face depth 3.3	M3 through	54	4	M3 through	11	34		
φ10	14	6	4 ^{+0.07} _{-0.02} depth 4	M5	1	4 ^{+0.07} _{-0.02} depth 4	20	4.3	8 spot face depth 4.4	M4 through	65	6	M4 through	13	42		
φ16	16	8	6 ^{+0.07} _{-0.02} depth 6	M5	1	6 ^{+0.07} _{-0.02} depth 6	25	4.3	8 spot face depth 4.4	M5 through	76	10	M5 through	19	52		
φ20	20	10	6 ^{+0.07} _{-0.02} depth 6	M5	1	6 ^{+0.07} _{-0.02} depth 6	28	5.2	9.5 spot face depth 5.4	M5 through	85	12	M5 through	24	60		
φ25	22	12	6 ^{+0.07} _{-0.02} depth 6	M5	1	6 ^{+0.07} _{-0.02} depth 6	34	6.3	11 spot face depth 6.5	M6 through	85	14	M6 through	30	70		
φ32	22	12	6 ^{+0.07} _{-0.02} depth 6	Rc1/8	1	6 ^{+0.07} _{-0.02} depth 6	44	6.3	11 spot face depth 6.5	M6 through	101	16	M6 through	36	94		

Code	K0/K5/K2/K3																		
Bore size (mm)	Q	R	S	T	WW	X	AX	BX	CX	DX	EX	FX	Z	A1	A2	A3	A4	HD	RD
φ 6	29	36	3	13	M4 depth 5	66	20	10	24	7	40	7	1.0	15	10	M3 depth 4	-	13.5	21
φ10	36	44	3	15	M5 depth 6	79	24	14	27	8	48	9	1.0	15	20	M3 depth 3.5	-	12.5	33
φ16	45	58	4	21	M5 depth 6	92	24	26	26	8	60	8	0.5	20	25	M4 depth 4	-	17	39.5
φ20	50	62	5	27	M6 depth 8	105	24	33	28	9	67	9	0.5	20	30	M4 depth 4	13	20.5	45
φ25	60	72	6	33	M8 depth 8	107	24	33	28	9	67	9	0.5	20	30	M5 depth 6	18	21.5	43.5
φ32	75	96	6	38	M8 depth 8	123	24	47	30	9	83	9	0.5	20	40	M5 depth 8	24	25.5	55.5

- *4 : STR2-B-6 and 10 are not compatible with K0 and K5 reed switches.
- *5 : The cylinder may tilt due to the uneven surface if it is installed with the spot face side (JJ) contacted. In this case, change the port position or use the option of piping port position on the 180° opposite side (O) to keep the spot face side from being the contacting surface.

- LCW
- LCR
- LCG
- LCX
- LCM
- STM
- STG
- STS/STL
- STR2**
- UCA2
- ULK*
- JSK/M2
- JSG
- JSC3/JSC4
- USSD
- UFCD
- USC
- JSB3
- LMB
- LML
- HCM
- HCA
- LBC
- CAC4
- UCAC2
- CAC-N
- UCAC-N
- RCC2
- RCS
- PCC
- SHC
- MCP
- GLC
- MFC
- BBS
- RRC
- GRC
- RV3*
- NHS
- HR
- LN
- Hand
- Chuk
- MecHnd/Chuk
- ShkAbs
- FJ
- FK
- SpdContr
- Ending

LCW
LCR
LCG
LCX
LCM
STM
STG
STS/STL
STR2
UCA2
ULK*
JSK/M2
JSG
JSC3/JSC4
USSD
UFCD
USC
JSB3
LMB
LML
HCM
HCA
LBC
CAC4
UCAC2
CAC-N
UCAC-N
RCC2
RCS
PCC
SHC
MCP
GLC
MFC
BBS
RRC
GRC
RV3*
NHS
HR
LN
Hand
Chuk
MecHnd/Chuk
ShkAbs
FJ
FK
SpdContr
Ending

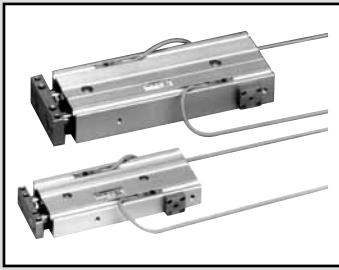

Twin rod cylinder/double acting/position locking

STR2-^M_BQ Series

● Bore size: φ16/φ20/φ25/φ32

JIS symbol

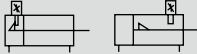

Specifications

Descriptions		STR2-MQ (metal bush bearing)				STR2-BQ (ball bearing)			
Bore size	mm	φ16	φ20	φ25	φ32				
Actuation		Double acting/position locking							
Working fluid		Compressed air							
Max. working pressure	MPa	0.7 (≈100 psi, 7 bar)							
Min. working pressure	MPa	0.15 (≈22 psi, 1.5 bar)							
Proof pressure	MPa	1.05 (≈150 psi, 10.5 bar)							
Ambient temperature	°C	-10 (14°F) to 60 (140°F) (no freezing)							
Port size		M5				Rc1/8			
Stroke tolerance	mm	+2.0 0							
Adjustable stroke range	mm	Not adjustable (with head side position locking)/0 to -5 (with rod side position locking)							
Working piston speed	mm/s	50 to 500							
Non-rotating accuracy (reference value)	STR2-M	±0.3°				±0.2°			
	STR2-B	±0.1°				±0.3°			
Piston rod bearing	STR2-M	Metal bush bearing							
	STR2-B	Ball bearing							
Cushion		Rubber cushion							
Lubrication		Not required (use turbine oil class 1 ISO VG32 if necessary for lubrication)							
Position locking mechanism		Rod side or head side							
Holding force	N	Max. thrust x 0.7							
Max absorbed energy	PUSH	0.181	0.303	0.68	1.3				
	PULL	0.083	0.127	0.237	0.311				

Stroke length

Bore size	Stroke length (mm)	Max. stroke length (mm)	Min. stroke length (mm)	Min. stroke with switch (mm)
φ16	10, 20, 30, 40, 50 60, 70, 80, 90, 100	100	5	10
φ20				
φ25				
φ32				

*1: Custom stroke length is available as custom order.

Theoretical thrust table

(Unit: N)

Bore size (mm)	Operating direction	Working pressure MPa							
		0.1	0.15	0.2	0.3	0.4	0.5	0.6	0.7
φ16	Push	40.2	60.3	80.4	1.21 × 10 ²	1.61 × 10 ²	2.01 × 10 ²	2.41 × 10 ²	2.81 × 10 ²
	Pull	24.5	36.8	49.0	73.5	98.0	1.23 × 10 ²	1.47 × 10 ²	1.72 × 10 ²
φ20	Push	62.8	94.2	1.26 × 10 ²	1.88 × 10 ²	2.51 × 10 ²	3.14 × 10 ²	3.77 × 10 ²	4.40 × 10 ²
	Pull	40.2	60.3	80.4	1.21 × 10 ²	1.61 × 10 ²	2.01 × 10 ²	2.41 × 10 ²	2.81 × 10 ²
φ25	Push	98.2	1.47 × 10 ²	1.96 × 10 ²	2.95 × 10 ²	3.93 × 10 ²	4.91 × 10 ²	5.89 × 10 ²	6.87 × 10 ²
	Pull	67.4	1.01 × 10 ²	1.35 × 10 ²	2.02 × 10 ²	2.70 × 10 ²	3.37 × 10 ²	4.04 × 10 ²	4.72 × 10 ²
φ32	Push	1.61 × 10 ²	2.41 × 10 ²	3.22 × 10 ²	4.83 × 10 ²	6.43 × 10 ²	8.04 × 10 ²	9.65 × 10 ²	1.13 × 10 ³
	Pull	1.21 × 10 ²	1.81 × 10 ²	2.41 × 10 ²	3.62 × 10 ²	4.83 × 10 ²	6.03 × 10 ²	7.24 × 10 ²	8.44 × 10 ²

⚠ Be sure to read the safety precautions of the **position locking STR2-Q** on pages 620 to 623 before use.

Switch specifications

- 1-color/2-color display

Descriptions	Proximity 2-wire		Proximity 3-wire			Reed 2-wire			
	K2H/K2V	K2YH/K2YV	K3H/K3V	K3PH/K3PV (Custom order)	K3YH/K3YV	K0H/K0V		K5H/K5V	
Applications	Dedicated for programmable controller		For programmable controller, relay			For programmable controller, relay		For programmable controller, relay, IC circuit (without indicator lamp), serial connection	
Output method	-		NPN output	PNP output	NPN output	-			
Power supply voltage	-		10 to 28 VDC			-			
Load voltage	10 to 30 VDC		30 VDC or less			12 VDC/24 VDC	110 VAC	5/12/24 VDC	110 VAC
Load current	5 to 20 mA (*1)		50 mA or less			5 to 50 mA	7 to 20 mA	50 mA or less	20 mA or less
Indicator lamp	LED (Lit when ON)	Red/green LED (Lit when ON)	LED (Lit when ON)	Yellow LED (Lit when ON)	Red/green LED (Lit when ON)	LED (Lit when ON)		-	
Leakage current	1 mA or less		10 µA or less			0 mA			
Weight g	1 m:18 3 m:49 5 m:80	1 m:31 3 m:85 5 m:139	1 m:18 3 m:49 5 m:80	1 m:31 3 m:85 5 m:139	1 m:31 3 m:85 5 m:139	1 m:18 3 m:49 5 m:80			

*1 : The above max. load current is 20 mA at 25°C. The current is lower than 20 mA if operating ambient temperature around the switch is higher than 25°C. (5 to 10 mA at 60°C)

*2 : Refer to Ending Page 1 for other switch specifications.

*3 : Dimensions depend on switch model No. Refer to Ending Page 21 for details.

Cylinder weight

Unit: g

Bore size	Product weight at 0 mm stroke		Additional weight per S = 10 mm
	STR2-M	STR2-B	
φ16	390	405	31
φ20	605	605	43
φ25	910	890	59
φ32	1430	1480	84

(Example) Product weight

STR2-MQ-16-10-H-K2H-D

- Product weight for 0 mm stroke length ... 390 g
- Additional weight for stroke length 10 mm ... 31 g x 1 = 31 g
- Weight of 2 cylinder switches ... 18 g x 2 = 36 g
- Product weight ... 390 g + 31 g + 36 g = 457 g

Specifications for rechargeable battery

(Catalog No. CC-1226A)

- Design compatible with rechargeable battery manufacturing process.

STR2-MQ-.....-P4*

LCW
LCR
LCG
LCX
LCM
STM
STG
STS/STL
STR2
UCA2
ULK*
JSK/M2
JSG
JSC3/JSC4
USSD
UFCD
USC
JSB3
LMB
LML
HCM
HCA
LBC
CAC4
UCAC2
CAC-N
UCAC-N
RCC2
RCS
PCC
SHC
MCP
GLC
MFC
BBS
RRC
GRC
RV3*
NHS
HR
LN
Hand
Chuk
MecHnd/Chuk
ShkAbs
FJ
FK
SpdContr
Ending

STR2-M^BQ Series

How to order

Without switch (built-in magnet for switch)

STR2 - (M) Q - (16) - (30) - (H) - (O)

With switch (built-in magnet for switch)

STR2 - (M) Q - (16) - (30) - (H) - (K0H) - (R) - (O)

Model No.

A Bearing

B Bore size

C Port thread

D Stroke length

Refer to page 584 for the min. stroke length.
 ■ Custom stroke length Available as custom-order.

E Position locking mechanism

F Switch model No.

G Switch quantity

H Option
*1

⚠ Precautions for model No. selection

*1: The piping port positions for "O" are as shown in the figure below.

Piping port position on the 180° opposite side
(Code: O) piping port

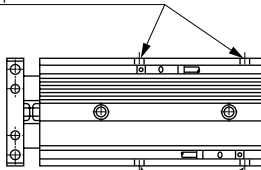

Piping port positions for standard (blank)

*2: In the case of G thread, ports on the opposite side (option "O") are not available. Rather than plug sealing, they are simply not provided. (The standard ports are not provided in the case of option "O".)

[Example of model No.]

STR2-MQ-16-30-H-K0H-R-O

Model: Twin rod cylinder, position locking

- A** Bearing : Metal bush bearing
- B** Bore size : φ16 mm
- C** Port thread : Rc thread
- D** Stroke length : 30 mm
- E** Position locking mechanism : With head side position locking
- F** Switch model No.: Reed K0H switch
- G** Switch quantity : 1 on rod side
- H** Option : Piping port position on the 180° opposite side

Code	Content					
A Bearing						
M	Metal bush bearing					
B	Ball bearing					
B Bore size (mm)						
16	φ16					
20	φ20					
25	φ25					
32	φ32					
C Port thread						
Blank	Rc thread					
NN	NPT thread (φ32 only) (custom order product)					
GN	G thread (φ32 only) (custom order product) *2					
D Stroke length (mm)						
10	10					
20	20					
30	30					
40	40					
50	50					
60	60					
70	70					
80	80					
90	90					
100	100					
E Position locking mechanism						
H	With head side position locking					
R	With rod side position locking					
F Switch model No.						
Axial lead wire	Radial lead wire	Contact	Voltage		Indicator	Lead wire
			AC	DC		
K0H*	K0V*	Reed	●	●	1-color display no indicator lamp	2-wire
			●	●		
K2H*	K2V*	Proximity		●	1-color display	2-wire
				●		
K3H*	K3V*	Proximity		●	1-color display (custom)	3-wire
				●		
K3PH*	K3PV*	Proximity		●	1-color display (custom)	3-wire
				●		
K2YH*	K2YV*	Proximity		●	2-color display	2-wire
				●		
K3YH*	K3YV*	Proximity		●	2-color display	3-wire
				●		
* Lead wire length						
Blank	1 m (standard)					
3	3 m (option)					
5	5 m (option)					
G Switch quantity						
R	1 on rod side					
H	1 on head side					
D	2					
H Option						
F	End plate material: steel					
O	Piping port position on the 180° opposite side					

How to order switch

SW - **K0H***

Switch model No.
(Item **F** above)

MEMO

LCW
LCR
LCG
LCX
LCM
STM
STG
STS/STL
STR2
UCA2
ULK*
JSK/M2
JSG
JSC3/JSC4
USSD
UFCD
USC
JSB3
LMB
LML
HCM
HCA
LBC
CAC4
UCAC2
CAC-N
UCAC-N
RCC2
RCS
PCC
SHC
MCP
GLC
MFC
BBS
RRC
GRC
RV3*
NHS
HR
LN
Hand
Chuk
MecHnd/Chuk
ShkAbs
FJ
FK
SpdContr
Ending

STR2-MQ Series

Internal structure and parts list (metal bush bearing)

- Position locking
with rod side position locking
STR2-MQ-R
- Piping port position on the 180° opposite side
STR2-MQ ... -R ... -O

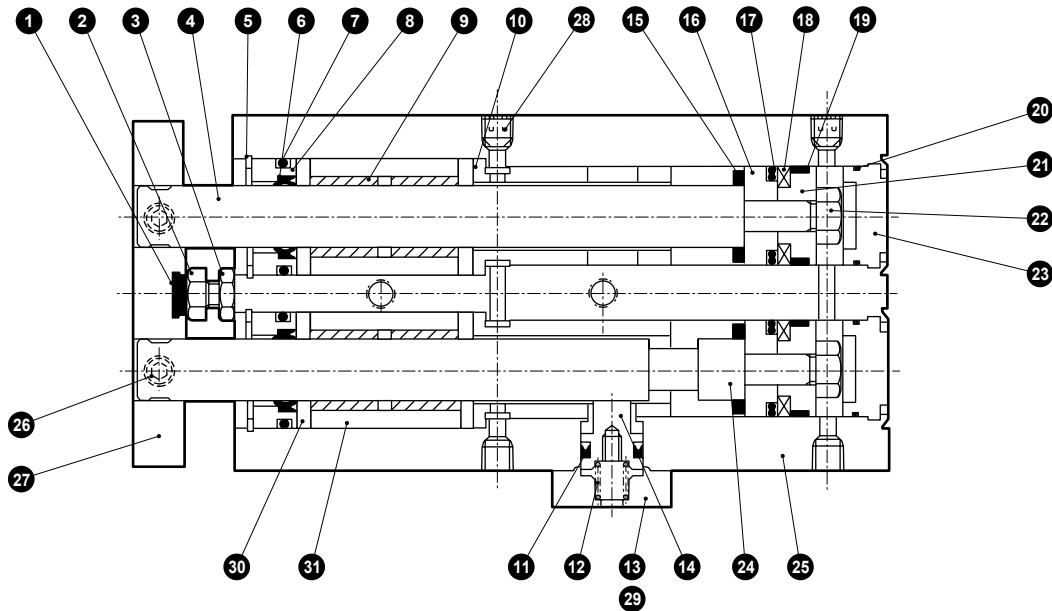

No.	Part name	Material	Remarks	No.	Part name	Material	Remarks
1	Cushion rubber (H)	Urethane rubber		17	Piston packing	Nitrile rubber	
2	Hexagon head bolt	Stainless steel		18	Magnet	Plastic	
3	Hexagon nut	Stainless steel		19	Wear ring	Acetal resin	
4	Piston rod (2)	Stainless steel (φ16, φ20) Steel (φ25, φ32)	Industrial chrome plating	20	O-ring	Nitrile rubber	
5	Snap ring for hole	Stainless steel		21	Spacer	Aluminum alloy	Chromate
6	Rod packing	Nitrile rubber		22	Hexagon nut	Steel	Zinc chromate
7	O-ring	Nitrile rubber		23	Cap	Aluminum alloy	Chromate
8	Housing	Aluminum alloy	Chromate	24	Piston rod (1)	Stainless steel (φ16, φ20) Steel (φ25, φ32)	Industrial chrome plating
9	Bush	Copper alloy		25	Cylinder body	Aluminum alloy	Hard alumite
10	Adaptor	Aluminum alloy	Chromate	26	Hexagon socket set screw	Stainless steel	
11	Stopper packing	Nitrile rubber		27	End plate	Aluminum alloy	Alumite
12	Coil spring	Piano wire	Electrodeposition	28	Hexagon socket set screw	Stainless steel	
13	Stopper cover	Aluminum alloy	Alumite	29	Hexagon socket head cap screw	Stainless steel	
14	Stopper piston	Stainless steel		30	Spacer	Aluminum alloy	Chromate
15	Cushion rubber (R)	Urethane rubber		31	Aluminum housing	Aluminum alloy	Chromate
16	Piston	Aluminum alloy	Chromate				

Repair parts list

Bore size (mm)	Kit No.	Repair parts No.
φ16	STR2-Q-16K	
φ20	STR2-Q-20K	1 6 7 11
φ25	STR2-Q-25K	15 17 19
φ32	STR2-Q-32K	

Note: Specify the kit No. when placing an order.

Internal structure and parts list (metal bush bearing)

- Position locking
with head side position locking
STR2-MQ-H
- Piping port position on the 180° opposite side
STR2-MQ-H ... -O

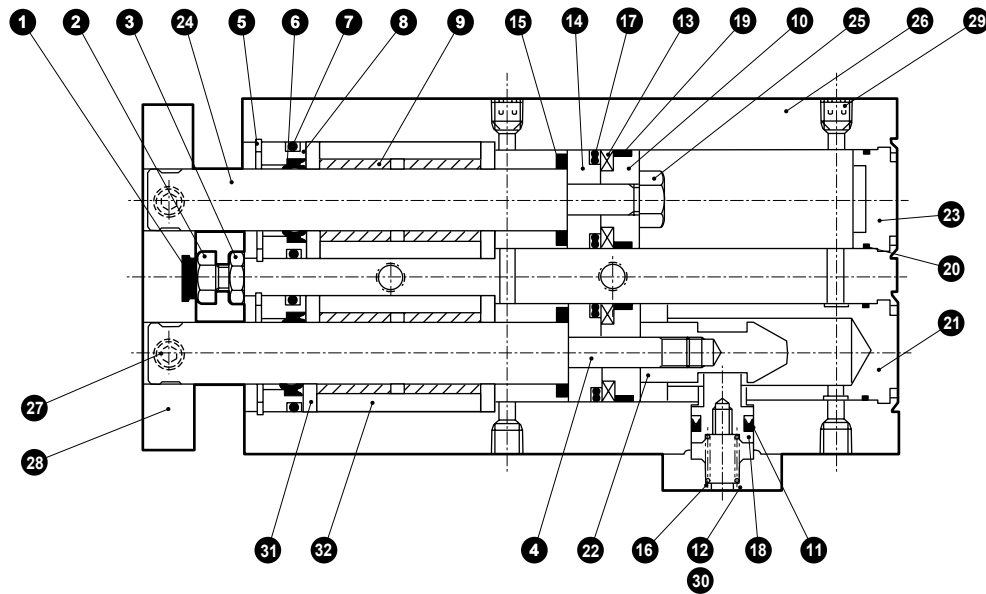

No.	Part name	Material	Remarks	No.	Part name	Material	Remarks
1	Cushion rubber (H)	Urethane rubber		17	Piston packing	Nitrile rubber	
2	Hexagon head bolt	Stainless steel		18	Stopper piston	Stainless steel	
3	Hexagon nut	Stainless steel		19	Wear ring	Acetal resin	
4	Piston rod (2)	Stainless steel (φ16, φ20) Steel (φ25, φ32)	Industrial chrome plating	20	O-ring	Nitrile rubber	
5	Snap ring for hole	Stainless steel		21	Head cover	Aluminum alloy	Chromate
6	Rod packing	Nitrile rubber		22	Sleeve	Stainless steel	
7	O-ring	Nitrile rubber		23	Cap	Aluminum alloy	Chromate
8	Housing	Aluminum alloy	Chromate	24	Piston rod (1)	Stainless steel (φ16, φ20) Steel (φ25, φ32)	Industrial chrome plating
9	Bush	Copper alloy		25	Hexagon nut	Steel	Zinc chromate
10	Spacer	Aluminum alloy	Chromate	26	Cylinder body	Aluminum alloy	Hard alumite
11	Stopper packing	Nitrile rubber		27	Hexagon socket set screw	Stainless steel	
12	Stopper cover	Aluminum alloy	Alumite	28	End plate	Aluminum alloy	Alumite
13	Magnet	Plastic		29	Hexagon socket set screw	Stainless steel	
14	Piston	Aluminum alloy	Chromate	30	Hexagon socket head cap screw	Stainless steel	
15	Cushion rubber (R)	Urethane rubber		31	Spacer	Aluminum alloy	Chromate
16	Coil spring	Piano wire	Electrodeposition	32	Aluminum housing	Aluminum alloy	Chromate

Repair parts list

Bore size (mm)	Kit No.	Repair parts No.
φ16	STR2-Q-16K	
φ20	STR2-Q-20K	1 6 7 11
φ25	STR2-Q-25K	15 17 19
φ32	STR2-Q-32K	

Note: Specify the kit No. when placing an order.

LCW
LCR
LCG
LCX
LCM
STM
STG
STS/STL
STR2
UCA2
ULK*
JSK/M2
JSG
JSC3/JSC4
USSD
UFCD
USC
JSB3
LMB
LML
HCM
HCA
LBC
CAC4
UCAC2
CAC-N
UCAC-N
RCC2
RCS
PCC
SHC
MCP
GLC
MFC
BBS
RRC
GRC
RV3*
NHS
HR
LN
Hand
Chuk
MecHnd/Chuk
ShkAbs
FJ
FK
SpdContr
Ending

STR2-BQ Series

LCW
LCR
LCG
LCX
LCM
STM
STG
STS/STL
STR2
UCA2
ULK*
JSK/M2
JSG
JSC3/JSC4
USSD
UFCD
USC
JSB3
LMB
LML
HCM
HCA
LBC
CAC4
UCAC2
CAC-N
UCAC-N
RCC2
RCS
PCC
SHC
MCP
GLC
MFC
BBS
RRC
GRC
RV3*
NHS
HR
LN
Hand
Chuk
MecHnd/Chuk
ShkAbs
FJ
FK
SpdContr
Ending

Internal structure and parts list (ball bearing)

- Position locking
with rod side position locking
STR2-BQ-R
- Piping port position on the 180° opposite side
STR2-BQ ... -R ... -O

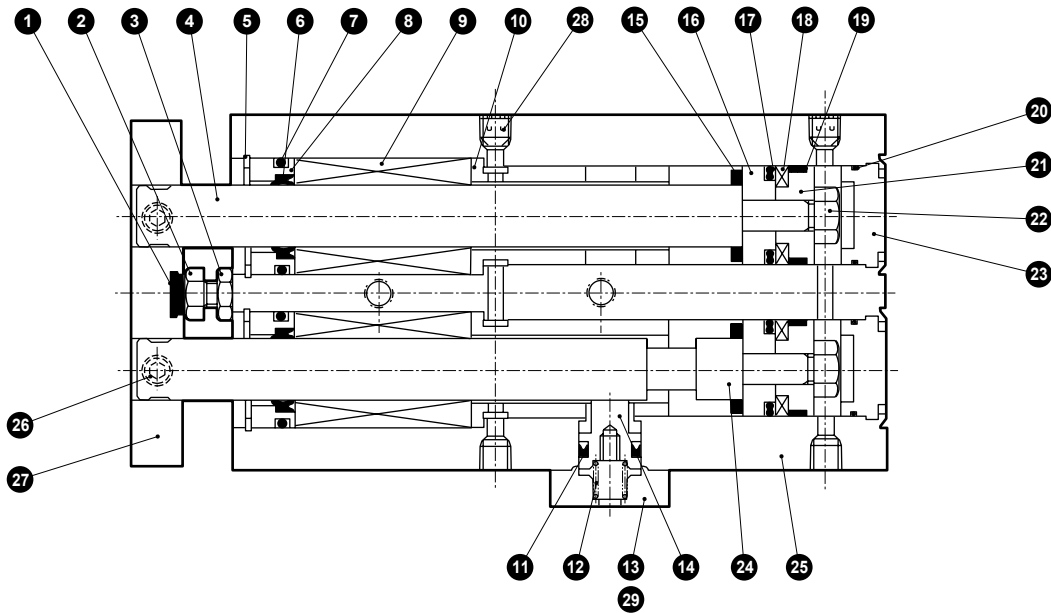

No.	Part name	Material	Remarks	No.	Part name	Material	Remarks
1	Cushion rubber (H)	Urethane rubber		16	Piston	Aluminum alloy	Chromate
2	Hexagon head bolt	Stainless steel		17	Piston packing	Nitrile rubber	
3	Hexagon nut	Stainless steel		18	Magnet	Plastic	
4	Piston rod (2)	Steel	Industrial chrome plating	19	Wear ring	Acetal resin	
5	Snap ring for hole	Stainless steel		20	O-ring	Nitrile rubber	
6	Rod packing	Nitrile rubber		21	Spacer	Aluminum alloy	Chromate
7	O-ring	Nitrile rubber		22	Hexagon nut	Steel	Zinc chromate
8	Housing	Aluminum alloy	Chromate	23	Cap	Aluminum alloy	Chromate
9	Bearing			24	Piston rod (1)	Steel	Industrial chrome plating
10	Adaptor	Aluminum alloy	Chromate	25	Cylinder body	Aluminum alloy	Hard alumite
11	Stopper packing	Nitrile rubber		26	Hexagon socket set screw	Stainless steel	
12	Coil spring	Piano wire	Electrodeposition	27	End plate	Aluminum alloy	Alumite
13	Stopper cover	Aluminum alloy	Alumite	28	Hexagon socket set screw	Stainless steel	
14	Stopper piston	Stainless steel		29	Hexagon socket head cap screw	Stainless steel	
15	Cushion rubber (R)	Urethane rubber					

Repair parts list

Bore size (mm)	Kit No.	Repair parts No.
φ16	STR2-Q-16K	
φ20	STR2-Q-20K	1 6 7 11
φ25	STR2-Q-25K	15 17 19
φ32	STR2-Q-32K	

Note: Specify the kit No. when placing an order.

Internal structure and parts list (ball bearing)

- Position locking
with head side position locking
STR2-BQ-H
- Piping port position on the 180° opposite side
STR2-BQ-H ... -O

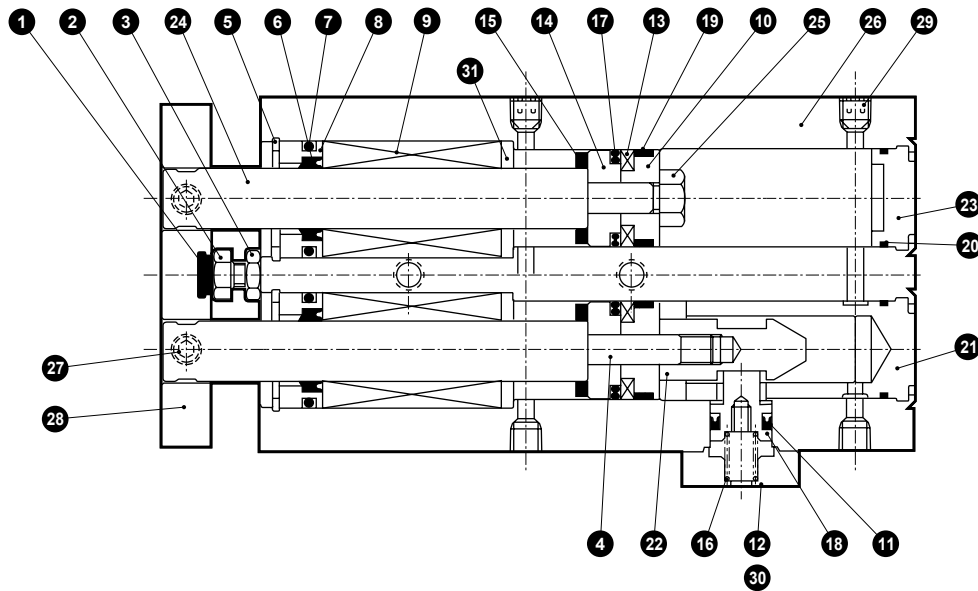

No.	Part name	Material	Remarks	No.	Part name	Material	Remarks
1	Cushion rubber (H)	Urethane rubber		17	Piston packing	Nitrile rubber	
2	Hexagon head bolt	Stainless steel		18	Stopper piston	Stainless steel	
3	Hexagon nut	Stainless steel		19	Wear ring	Acetal resin	
4	Piston rod (2)	Steel	Industrial chrome plating	20	O-ring	Nitrile rubber	
5	Snap ring for hole	Stainless steel		21	Head cover	Aluminum alloy	Chromate
6	Rod packing	Nitrile rubber		22	Sleeve	Stainless steel	
7	O-ring	Nitrile rubber		23	Cap	Aluminum alloy	Chromate
8	Housing	Aluminum alloy	Chromate	24	Piston rod (1)	Steel	Industrial chrome plating
9	Bearing			25	Hexagon nut	Steel	Zinc chromate
10	Spacer	Aluminum alloy	Chromate	26	Cylinder body	Aluminum alloy	Hard alumite
11	Stopper packing	Nitrile rubber		27	Hexagon socket set screw	Stainless steel	
12	Stopper cover	Aluminum alloy	Alumite	28	End plate	Aluminum alloy	Alumite
13	Magnet	Plastic		29	Hexagon socket set screw	Stainless steel	
14	Piston	Aluminum alloy	Chromate	30	Hexagon socket head cap screw	Stainless steel	
15	Cushion rubber (R)	Urethane rubber		31	Spacer	Aluminum alloy	Chromate
16	Coil spring	Piano wire	Electrodeposition				

Repair parts list

Bore size (mm)	Kit No.	Repair parts No.
φ16	STR2-Q-16K	
φ20	STR2-Q-20K	1 6 7 11
φ25	STR2-Q-25K	15 17 19
φ32	STR2-Q-32K	

Note: Specify the kit No. when placing an order.

LCW
LCR
LCG
LCX
LCM
STM
STG
STS/STL
STR2
UCA2
ULK*
JSK/M2
JSG
JSC3/JSC4
USSD
UFCD
USC
JSB3
LMB
LML
HCM
HCA
LBC
CAC4
UCAC2
CAC-N
UCAC-N
RCC2
RCS
PCC
SHC
MCP
GLC
MFC
BBS
RRC
GRC
RV3*
NHS
HR
LN
Hand
Chuk
MecHnd/Chuk
ShkAbs
FJ
FK
SpdContr
Ending

STR2-M_BQ Series



Dimensions (φ16 to φ32)

- Position locking (Q), head side position locking (H) and piping port position on the 180° opposite side (O)

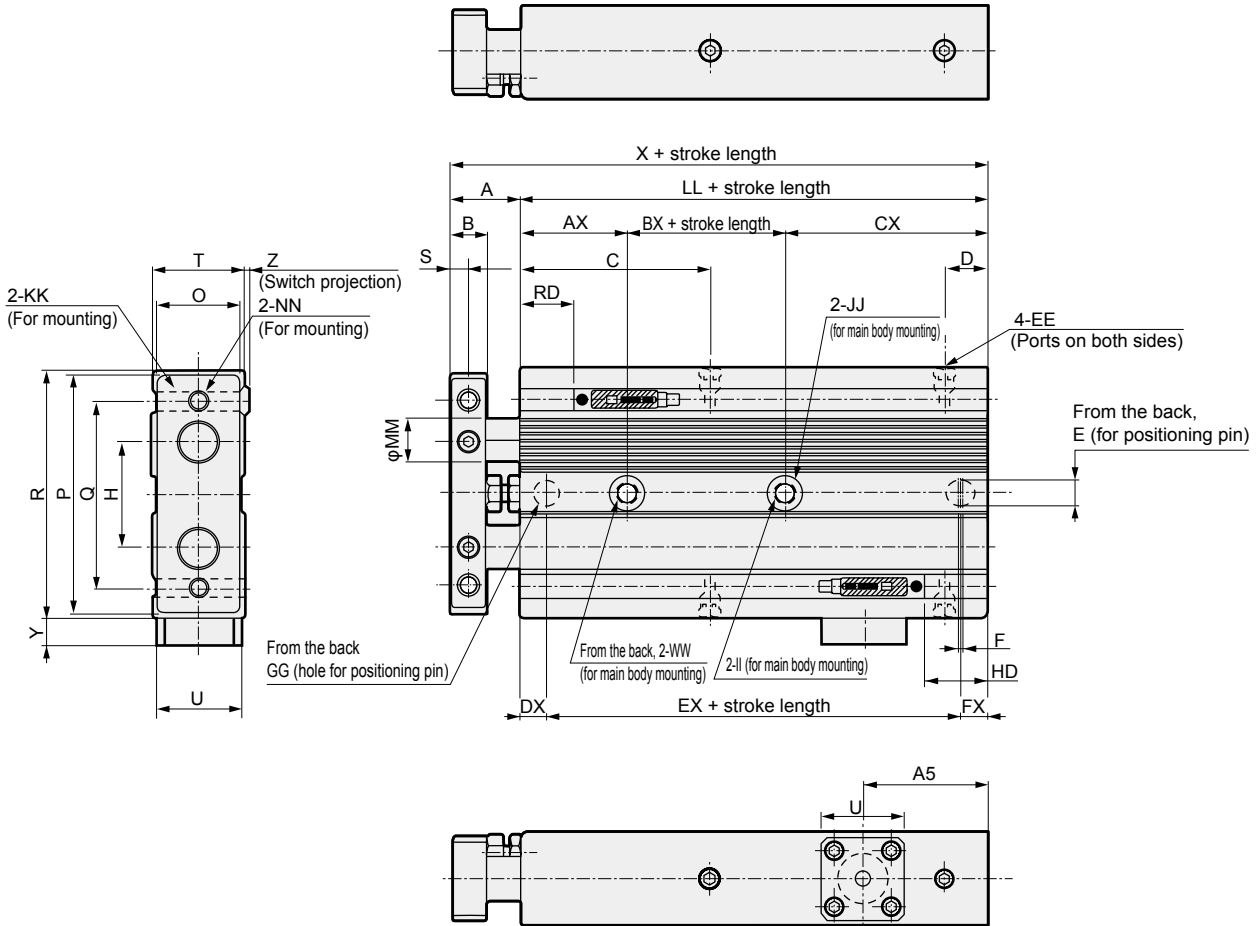

*1 : HD and RD dimensions for 10 mm stroke length differ from these dimensions according to the setting.

*2 : Refer to page 610 for HD, RD and protruding dimensions of the 2-color display switch.

*3 : The cylinder may tilt due to the uneven surface if it is installed with the spot face side (JJ) contacted. In this case, change the port position or use the option of piping port position on the 180° opposite side (O) to keep the spot face side from being the contacting surface.

Code	Q-H Basic dimensions																
Bore size (mm)	A	B	C	D	E	EE	F	GG	H	II	JJ	KK	LL	MM	NN	O	P
φ16	16	8	43	9.5	6 ^{-0.07} / _{-0.02} depth 6	M5	1	6 ^{-0.07} / _{-0.02} depth 6	25	4.3	8 spot face depth 4.4	M5 through	96	10	M5 through	19	52
φ20	20	10	46	9.5	6 ^{-0.07} / _{-0.02} depth 6	M5	1	6 ^{-0.07} / _{-0.02} depth 6	28	5.2	9.5 spot face depth 5.4	M5 through	105	12	M5 through	24	60
φ25	22	12	44	10.5	6 ^{-0.07} / _{-0.02} depth 6	M5	1	6 ^{-0.07} / _{-0.02} depth 6	34	6.3	11 spot face depth 6.5	M6 through	105	14	M6 through	30	70
φ32	22	12	56	11	6 ^{-0.07} / _{-0.02} depth 6	Rc1/8	1	6 ^{-0.07} / _{-0.02} depth 6	44	6.3	11 spot face depth 6.5	M6 through	121	16	M6 through	36	94

Code	K0/K5/K2/K3																	
Bore size (mm)	Q	R	S	T	U	WW	X	Y	AX	BX	CX	DX	EX	FX	Z	A5	HD	RD
φ16	45	58	4	21	19	M5 depth 6	112	6	24	26	46	8	80	8	0.5	28	37	39.5
φ20	50	62	5	27	23	M6 depth 8	125	7.5	24	33	48	9	87	9	0.5	25	40.5	45
φ25	60	72	6	33	23	M8 depth 8	127	7.5	24	33	48	9	87	9	0.5	28	41.5	43.5
φ32	75	96	6	38	23	M8 depth 8	143	7.5	24	47	50	9	103	9	0.5	27.5	45.5	55.5

Dimensions (φ16 to φ32)



- Position locking (Q), rod side position locking (R) and piping port position on the 180° opposite side (O)

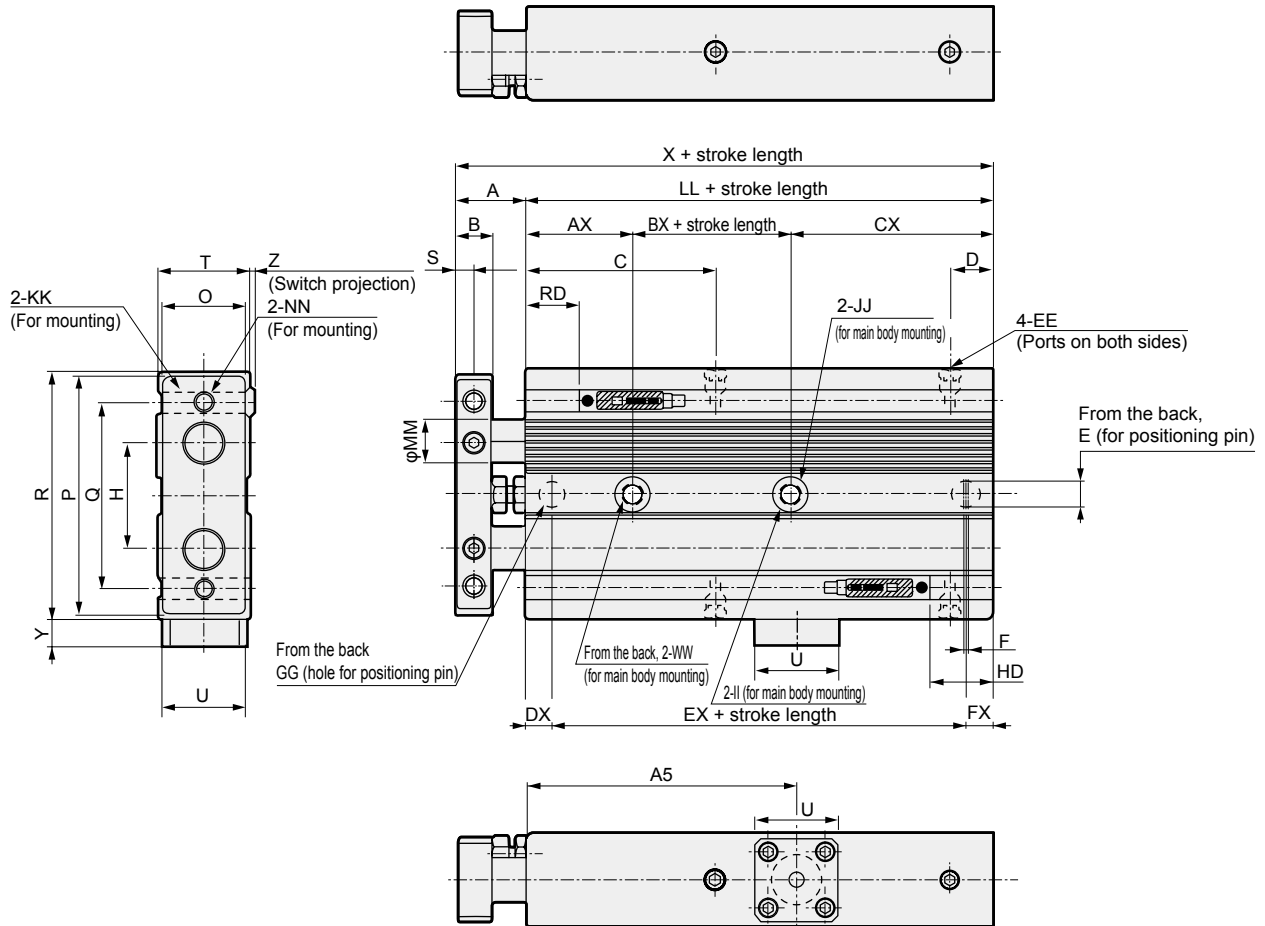

*1 : HD and RD dimensions for 10 mm stroke length differ from these dimensions according to the setting.

*2 : Refer to page 610 for HD, RD and protruding dimensions of the 2-color display switch.

*3 : The cylinder may tilt due to the uneven surface if it is installed with the spot face side (JJ) contacted. In this case, change the port position or use the option of piping port position on the 180° opposite side (O) to keep the spot face side from being the contacting surface.

Code	Q-R Basic dimensions																
Bore size (mm)	A	B	C	D	E	EE	F	GG	H	II	JJ	KK	LL	MM	NN	O	P
φ16	16	8	43	9.5	6 ^{-0.07} / _{-0.02} depth 6	M5	1	6 ^{-0.07} / _{-0.02} depth 6	25	4.3	8 spot face depth 4.4	M5 through	96	10	M5 through	19	52
φ20	20	10	46	9.5	6 ^{-0.07} / _{-0.02} depth 6	M5	1	6 ^{-0.07} / _{-0.02} depth 6	28	5.2	9.5 spot face depth 5.4	M5 through	105	12	M5 through	24	60
φ25	22	12	44	10.5	6 ^{-0.07} / _{-0.02} depth 6	M5	1	6 ^{-0.07} / _{-0.02} depth 6	34	6.3	11 spot face depth 6.5	M6 through	105	14	M6 through	30	70
φ32	22	12	56	11	6 ^{-0.07} / _{-0.02} depth 6	Rc1/8	1	6 ^{-0.07} / _{-0.02} depth 6	44	6.3	11 spot face depth 6.5	M6 through	121	16	M6 through	36	94

Code	Q-R Basic dimensions															K0/K5/K2/K3		
Bore size (mm)	Q	R	S	T	U	WW	X	Y	AX	BX	CX	DX	EX	FX	Z	A5	HD	RD
φ16	45	58	4	21	19	M5 depth 6	112	6	24	26	46	8	80	8	0.5	61.5	7	69.5
φ20	50	62	5	27	23	M6 depth 8	125	7.5	24	33	48	9	87	9	0.5	61.5	10.5	75
φ25	60	72	6	33	23	M8 depth 8	127	7.5	24	33	48	9	87	9	0.5	61.5	11.5	73.5
φ32	75	96	6	38	23	M8 depth 8	143	7.5	24	47	50	9	103	9	0.5	72.5	15.5	85.5

- LCW
- LCR
- LCG
- LCX
- LCM
- STM
- STG
- STS/STL
- STR2**
- UCA2
- ULK*
- JSK/M2
- JSG
- JSC3/JSC4
- USSD
- UFCD
- USC
- JSB3
- LMB
- LML
- HCM
- HCA
- LBC
- CAC4
- UCAC2
- CAC-N
- UCAC-N
- RCC2
- RCS
- PCC
- SHC
- MCP
- GLC
- MFC
- BBS
- RRC
- GRC
- RV3*
- NHS
- HR
- LN
- Hand
- Chuk
- MecHnd/Chuk
- ShkAbs
- FJ
- FK
- SpdContr
- Ending



Twin rod cylinder/double acting/low speed

STR2-M^BO Series

● Bore size: φ6/φ10/φ16/φ20/φ25/φ32

JIS symbol



Specifications

Descriptions		STR2-MO (metal bush bearing)			STR2-BO (ball bearing)		
Bore size	mm	φ6	φ10	φ16	φ20	φ25	φ32
Actuation		Double acting/low speed					
Working fluid		Compressed air					
Max. working pressure	MPa	0.7 (≈100 psi, 7 bar)					
Min. working pressure	MPa	0.2 (≈29 psi, 2 bar)	0.15 (≈22 psi, 1.5 bar)	0.1 (≈15 psi, 1 bar)			
Proof pressure	MPa	1.05 (≈150 psi, 10.5 bar)					
Ambient temperature	°C	-10 (14°F) to 60 (140°F) (no freezing)					
Port size		M5					Rc1/8
Stroke tolerance	mm	+2.0					
		0					
Adjustable stroke range	mm	0 to -5					
Working piston speed	mm/s	10 to 200					
Non-rotating accuracy (reference value)	STR2-M	±0.4°		±0.3°			±0.2°
	STR2-B	±0.2°		±0.1°			±0.3°
Piston rod	STR2-M	Metal bush bearing					
Bearing	STR2-B	Ball bearing					
Cushion		Rubber cushion					
Lubrication		Not available					
Max absorbed energy	PUSH	0.008	0.061	0.181	0.303	0.68	1.3
	PULL	0.059	0.083	0.083	0.127	0.237	0.311

Stroke length

Bore size	Stroke length (mm)	Max. stroke length (mm)	Min. stroke length (mm)	Min. stroke with switch (mm)
φ6	10, 20, 30, 40, 50	50	5	10
φ10				
φ16	10, 20, 30, 40, 50 60, 70, 80, 90, 100	100		
φ20				
φ25				
φ32				

Note: The custom stroke length is available in 1 mm increments.

However, the total length is the same as that of the next longer standard stroke length.

Theoretical thrust table

(Unit: N)

Bore size (mm)	Operating direction	Working pressure MPa							
		0.1	0.15	0.2	0.3	0.4	0.5	0.6	0.7
φ6	Push	-	-	11.3	17.0	22.6	28.3	33.9	39.6
	Pull	-	-	6.28	9.42	12.6	15.7	18.8	22.0
φ10	Push	-	-	31.4	47.1	62.8	78.5	94.2	1.10 × 10 ²
	Pull	-	-	20.1	30.2	40.2	50.3	60.3	70.4
φ16	Push	40.2	60.3	80.4	1.21 × 10 ²	1.61 × 10 ²	2.01 × 10 ²	2.41 × 10 ²	2.81 × 10 ²
	Pull	24.5	36.8	49.0	73.5	98.0	1.23 × 10 ²	1.47 × 10 ²	1.72 × 10 ²
φ20	Push	62.8	94.2	1.26 × 10 ²	1.88 × 10 ²	2.51 × 10 ²	3.14 × 10 ²	3.77 × 10 ²	4.40 × 10 ²
	Pull	40.2	60.3	80.4	1.21 × 10 ²	1.61 × 10 ²	2.01 × 10 ²	2.41 × 10 ²	2.81 × 10 ²
φ25	Push	98.2	1.47 × 10 ²	1.96 × 10 ²	2.95 × 10 ²	3.93 × 10 ²	4.91 × 10 ²	5.89 × 10 ²	6.87 × 10 ²
	Pull	67.4	1.01 × 10 ²	1.35 × 10 ²	2.02 × 10 ²	2.70 × 10 ²	3.37 × 10 ²	4.04 × 10 ²	4.72 × 10 ²
φ32	Push	1.61 × 10 ²	2.41 × 10 ²	3.22 × 10 ²	4.83 × 10 ²	6.43 × 10 ²	8.04 × 10 ²	9.65 × 10 ²	1.13 × 10 ³
	Pull	1.21 × 10 ²	1.81 × 10 ²	2.41 × 10 ²	3.62 × 10 ²	4.83 × 10 ²	6.03 × 10 ²	7.24 × 10 ²	8.44 × 10 ²

Switch specifications

- 1-color/2-color display

Descriptions	Proximity 2-wire		Proximity 3-wire			Reed 2-wire				
	K2H/K2V	K2YH/ K2YV	K3H/K3V	K3PH/K3PV (custom order)	K3YH/ K3YV	K0H/K0V		K5H/K5V		
Applications	Dedicated for programmable controller		For programmable controller, relay			For programmable controller, relay		For programmable controller, relay, IC circuit (without indicator lamp), serial connection		
Output method	-		NPN output	PNP output	NPN output	-				
Power supply voltage	-		10 to 28 VDC			-				
Load voltage	10 to 30 VDC		30 VDC or less			12 VDC/24 VDC	110 VAC	5/12/24 VDC	110 VAC	
Load current	5 to 20 mA (*1)		50 mA or less			5 to 50 mA	7 to 20 mA	50 mA or less	20 mA or less	
Indicator lamp	LED (Lit when ON)	Red/green LED (Lit when ON)	LED (Lit when ON)	Yellow LED (Lit when ON)	Red/green LED (Lit when ON)	LED (Lit when ON)		-		
Leakage current	1 mA or less		10 μA or less			0 mA				
Weight	g	1 m:18 3 m:49 5 m:80	1 m:31 3 m:85 5 m:139	1 m:18 3 m:49 5 m:80	1 m:31 3 m:85 5 m:139	1 m:18 3 m:49 5 m:80				

*1 : The above max. load current is 20 mA at 25°C. The current is lower than 20 mA if operating ambient temperature around the switch is higher than 25°C. (5 to 10 mA at 60°C)

*2 : Refer to Ending Page 1 for other switch specifications.

*3 : Dimensions depend on switch model No. Refer to Ending Page 21 for details.

Cylinder weight

Unit: g

Bore size	Product weight at 0 mm stroke		Additional weight per S = 10 mm
	STR2-M	STR2-B	
φ6	60	64	10
φ10	140	155	14
φ16	240	300	20
φ20	340	405	40
φ25	580	610	52
φ32	1300	1150	83

(Example) Product weight

STR2-M-6-10-K2H-D

- Product weight for 0 mm stroke length ... 60 g
- Additional weight for stroke length 10 mm ... 10 g x 1 = 10 g
- Weight of 2 cylinder switches ... 18 g x 2 = 36 g
- Product weight ... 60 g + 10 g + 36 g = 106 g

LCW
LCR
LCG
LCX
LCM
STM
STG
STS/STL
STR2
UCA2
ULK*
JSK/M2
JSG
JSC3/JSC4
USSD
UFCD
USC
JSB3
LMB
LML
HCM
HCA
LBC
CAC4
UCAC2
CAC-N
UCAC-N
RCC2
RCS
PCC
SHC
MCP
GLC
MFC
BBS
RRC
GRC
RV3*
NHS
HR
LN
Hand
Chuk
MecHnd/Chuk
ShkAbs
FJ
FK
SpdContr
Ending

STR2-M^BO Series

How to order

Without switch (built-in magnet for switch)

STR2 - (M) O - (16) - (30) - (O)

With switch (built-in magnet for switch)

STR2 - (M) O - (16) - (30) - (K0H) - (R) - (O)

Model No.

A Bearing

B Bore size

C Port thread

D Stroke length

■ Custom stroke length
Available in 1 mm increments.
However, the total length is the same as that of the next longer standard stroke length.

E Switch model No.
*1

F Switch quantity

G Option
*2

⚠ Precautions for model No. selection

*1 : STR2-B-6 and 10 are not compatible with a reed switch.

*2 : The piping port positions for "O" are as shown in the figure below.

Piping port positions for standard (blank)

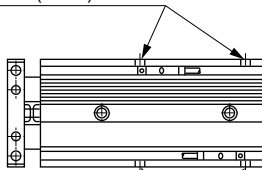

Piping port position on the 180° opposite side (Code: O) piping port

*3 : In the case of G thread, ports on the opposite side (option "O") are not available. Rather than plug sealing, they are simply not provided.
(The standard ports are not provided in the case of option "O".)

[Example of model No.]

STR2-MO-16-30-K0H-R-O

Model: Twin rod cylinder, low speed

- A** Bearing : Metal bush bearing
- B** Bore size : φ16 mm
- C** Port thread : Rc thread
- D** Stroke length : 30 mm
- E** Switch model No. : Reed K0H switch
- F** Switch quantity : 1 on rod side
- G** Option : Piping port position on the 180° opposite side

Code	Content					
A Bearing						
M	Metal bush bearing					
B	Ball bearing					
B Bore size (mm)						
6	φ6					
10	φ10					
16	φ16					
20	φ20					
25	φ25					
32	φ32					
C Port thread						
Blank	Rc thread					
NN	NPT thread (φ32 only) (custom order product)					
GN	G thread (φ32 only) (custom order product) *3					
D Stroke length (mm)						
Bore size	Stroke length	Custom stroke length				
φ6	5 to 50	In 1 mm increments				
φ10	5 to 50					
φ16	5 to 100					
φ20	5 to 100					
φ25	5 to 100					
φ32	5 to 100					
E Switch model No.						
Axial lead wire	Radial lead wire	Contact	Voltage	Indicator	Lead wire	
			AC	DC		
K0H*	K0V*	Reed	●	●	1-color display	2-wire
K5H*	K5V*		●	●	no indicator lamp	
K2H*	K2V*	Proximity	●	●	1-color display	2-wire
K3H*	K3V*		●	●	1-color display (custom)	3-wire
K3PH*	K3PV*		●	●	1-color display (custom)	3-wire
K2YH*	K2YV*		●	●	2-color display	2-wire
K3YH*	K3YV*	●	●	2-color display	3-wire	
* Lead wire length						
Blank	1 m (standard)					
3	3 m (option)					
5	5 m (option)					
F Switch quantity						
R	1 on rod side					
H	1 on head side					
D	2					
G Option						
F	End plate material: steel					
O	Piping port position on the 180° opposite side					

How to order switch

SW - K0H*

Switch model No.
(Item **E** above)

MEMO

LCW
LCR
LCG
LCX
LCM
STM
STG
STS/STL
STR2
UCA2
ULK*
JSK/M2
JSG
JSC3/JSC4
USSD
UFCD
USC
JSB3
LMB
LML
HCM
HCA
LBC
CAC4
UCAC2
CAC-N
UCAC-N
RCC2
RCS
PCC
SHC
MCP
GLC
MFC
BBS
RRC
GRC
RV3*
NHS
HR
LN
Hand
Chuk
MecHnd/Chuk
ShkAbs
FJ
FK
SpdContr
Ending

STR2-MO Series

- LCW
- LCR
- LCG
- LCX
- LCM
- STM
- STG
- STS/STL
- STR2**
- UCA2
- ULK*
- JSK/M2
- JSG
- JSC3/JSC4
- USSD
- UFCD
- USC
- JSB3
- LMB
- LML
- HCM
- HCA
- LBC
- CAC4
- UCAC2
- CAC-N
- UCAC-N
- RCC2
- RCS
- PCC
- SHC
- MCP
- GLC
- MFC
- BBS
- RRC
- GRC
- RV3*
- NHS
- HR
- LN
- Hand
- Chuk
- MecHnd/Chuk
- ShkAbs
- FJ
- FK
- SpdContr
- Ending

Internal structure and parts list (metal bush bearing $\phi 6/\phi 10$)

- Low speed
- STR2-MO**
- Piping port position on the 180° opposite side
- STR2-MO ... -O**

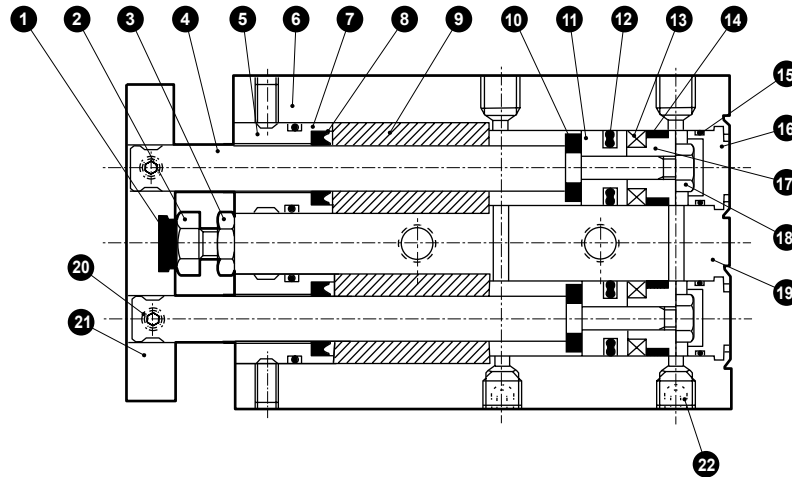

No.	Part name	Material	Remarks	No.	Part name	Material	Remarks
1	Cushion rubber (H)	Urethane rubber		12	Piston packing	Nitrile rubber	
2	Hexagon head bolt	Stainless steel		13	Magnet	Plastic	
3	Hexagon nut	Stainless steel		14	Wear ring	Acetal resin	
4	Piston rod	Stainless steel		15	O-ring	Nitrile rubber	
5	Housing	Stainless steel		16	Cap	Aluminum alloy	Chromate
6	Hexagon socket set screw	Stainless steel		17	Spacer	Aluminum alloy	Chromate
7	O-ring	Nitrile rubber		18	Hexagon nut	Steel	Zinc chromate
8	Rod packing	Nitrile rubber		19	Cylinder body	Aluminum alloy	Hard alumite
9	Bush *1	Copper alloy		20	Hexagon socket set screw	Stainless steel	
10	Cushion rubber (R)	Urethane rubber		21	End plate *2	Aluminum alloy	Alumite
11	Piston	Aluminum alloy	Chromate	22	Hexagon socket set screw	Stainless steel	

Repair parts list

STR2-MO (low speed) * Repair parts other than the piston packing are the same as those of the standard.

Bore size (mm)	Kit No.	Repair parts No.
$\phi 6$	STR2-O-6K	1 7 8 10 12 14
$\phi 10$	STR2-O-10K	

Note: Specify the kit No. when placing an order.

Internal structure and parts list (metal bush bearing $\phi 16/\phi 20/\phi 25/\phi 32$)

- Low speed
STR2-MO
- Piping port position on the 180° opposite side
STR2-MO ... -O

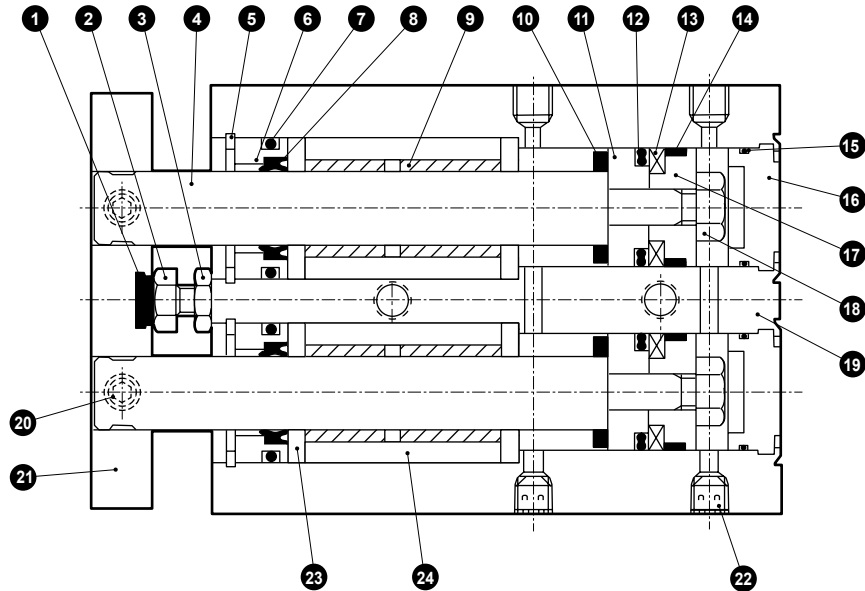

No.	Part name	Material	Remarks	No.	Part name	Material	Remarks
1	Cushion rubber (H)	Urethane rubber		13	Magnet	Plastic	
2	Hexagon head bolt	Stainless steel		14	Wear ring	Acetal resin	
3	Hexagon nut	Stainless steel		15	O-ring	Nitrile rubber	
4	Piston rod	Stainless steel ($\phi 16, \phi 20$) Steel ($\phi 25, \phi 32$)	Industrial chrome plating	16	Cap	Aluminum alloy	Chromate
5	Snap ring for hole	Stainless steel		17	Spacer	Aluminum alloy	Chromate
6	Housing	Aluminum alloy	Chromate	18	Hexagon nut	Steel	Zinc chromate
7	O-ring	Nitrile rubber		19	Cylinder body	Aluminum alloy	Hard alumite
8	Rod packing	Nitrile rubber		20	Hexagon socket set screw	Stainless steel	
9	Bush *1	Copper alloy		21	End plate *2	Aluminum alloy	Alumite
10	Cushion rubber (R)	Urethane rubber		22	Hexagon socket set screw	Stainless steel	
11	Piston	Aluminum alloy	Chromate	23	Spacer	Aluminum alloy	Chromate
12	Piston packing	Nitrile rubber		24	Aluminum housing	Aluminum alloy	Chromate

Repair parts list

STR2-MO (low speed) * Repair parts other than the piston packing are the same as those of the standard.

Bore size (mm)	Kit No.	Repair parts No.
$\phi 16$	STR2-O-16K	
$\phi 20$	STR2-O-20K	1 7 8
$\phi 25$	STR2-O-25K	10 12 14
$\phi 32$	STR2-O-32K	

Note: Specify the kit No. when placing an order.

LCW
LCR
LCG
LCX
LCM
STM
STG
STS/STL
STR2
UCA2
ULK*
JSK/M2
JSG
JSC3/JSC4
USSD
UFCD
USC
JSB3
LMB
LML
HCM
HCA
LBC
CAC4
UCAC2
CAC-N
UCAC-N
RCC2
RCS
PCC
SHC
MCP
GLC
MFC
BBS
RRC
GRC
RV3*
NHS
HR
LN
Hand
Chuk
MecHnd/Chuk
ShkAbs
FJ
FK
SpdContr
Ending

STR2-BO Series

LCW
LCR
LCG
LCX
LCM
STM
STG
STS/STL
STR2
UCA2
ULK*
JSK/M2
JSG
JSC3/JSC4
USSD
UFCD
USC
JSB3
LMB
LML
HCM
HCA
LBC
CAC4
UCAC2
CAC-N
UCAC-N
RCC2
RCS
PCC
SHC
MCP
GLC
MFC
BBS
RRC
GRC
RV3*
NHS
HR
LN
Hand
Chuk
MecHnd/Chuk
ShkAbs
FJ
FK
SpdContr
Ending

Internal structure and parts list (ball bearing $\phi 6/\phi 10$)

- Low speed
STR2-BO
- Piping port position on the 180° opposite side
STR2-BO ... -O

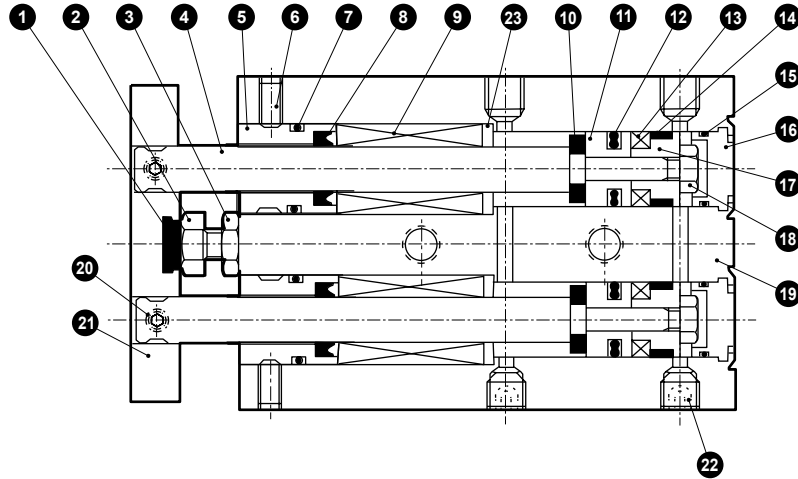

No.	Part name	Material	Remarks	No.	Part name	Material	Remarks
1	Cushion rubber (H)	Urethane rubber		13	Magnet	Plastic	
2	Hexagon head bolt	Stainless steel		14	Wear ring	Acetal resin	
3	Hexagon nut	Stainless steel		15	O-ring	Nitrile rubber	
4	Piston rod	Steel	Industrial chrome plating	16	Cap	Aluminum alloy	Chromate
5	Housing	Stainless steel		17	Spacer	Aluminum alloy	Chromate
6	Hexagon socket set screw	Stainless steel		18	Hexagon nut	Steel	Zinc chromate
7	O-ring	Nitrile rubber		19	Cylinder body	Aluminum alloy	Hard alumite
8	Rod packing	Nitrile rubber		20	Hexagon socket set screw	Stainless steel	
9	Bearing			21	End plate *1	Aluminum alloy	Alumite
10	Cushion rubber (R)	Urethane rubber		22	Hexagon socket set screw	Stainless steel	
11	Piston	Aluminum alloy	Chromate	23	Spacer	Aluminum alloy	Chromate
12	Piston packing	Nitrile rubber					

Repair parts list

STR2-BO (low speed) * Repair parts other than the piston packing are the same as those of the standard.

Bore size (mm)	Kit No.	Repair parts No.
$\phi 6$	STR2-O-6K	1 7 8 10 12 14
$\phi 10$	STR2-O-10K	

Note: Specify the kit No. when placing an order.

Internal structure and parts list (ball bearing $\phi 16/\phi 20/\phi 25/\phi 32$)

- Low speed
STR2-BO
- Piping port position on the 180° opposite side
STR2-BO ... -O

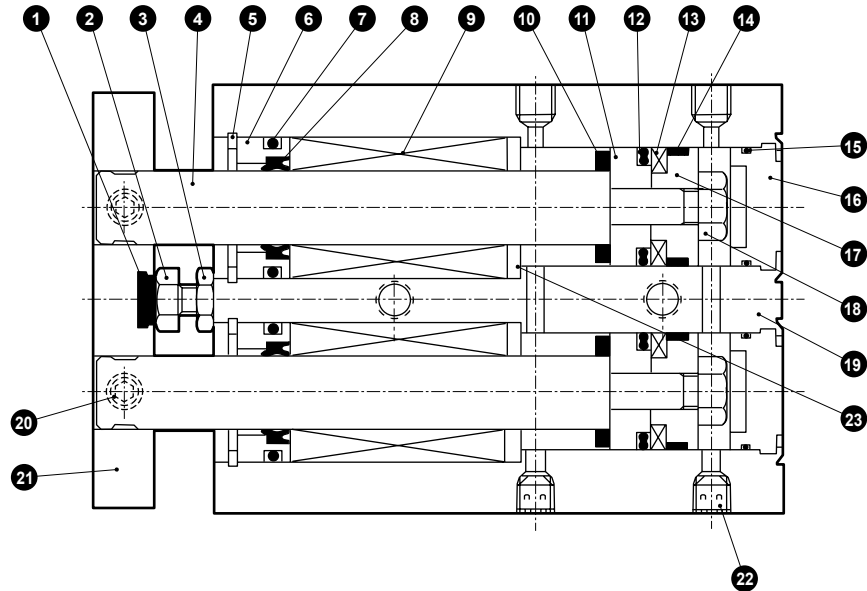

No.	Part name	Material	Remarks	No.	Part name	Material	Remarks
1	Cushion rubber (H)	Urethane rubber		13	Magnet	Plastic	
2	Hexagon head bolt	Stainless steel		14	Wear ring	Acetal resin	
3	Hexagon nut	Stainless steel		15	O-ring	Nitrile rubber	
4	Piston rod	Steel	Industrial chrome plating	16	Cap	Aluminum alloy	Chromate
5	Snap ring for hole	Stainless steel		17	Spacer	Aluminum alloy	Chromate
6	Housing	Aluminum alloy	Chromate	18	Hexagon nut	Steel	Zinc chromate
7	O-ring	Nitrile rubber		19	Cylinder body	Aluminum alloy	Hard alumite
8	Rod packing	Nitrile rubber		20	Hexagon socket set screw	Stainless steel	
9	Bearing			21	End plate *1	Aluminum alloy	Alumite
10	Cushion rubber (R)	Urethane rubber		22	Hexagon socket set screw	Stainless steel	
11	Piston	Aluminum alloy	Chromate	23	Spacer	Aluminum alloy	Chromate
12	Piston packing	Nitrile rubber					

Repair parts list

STR2-BO (low speed) * Repair parts other than the piston packing are the same as those of the standard.

Bore size (mm)	Kit No.	Repair parts No.
$\phi 16$	STR2-O-16K	
$\phi 20$	STR2-O-20K	1 7 8
$\phi 25$	STR2-O-25K	10 12 14
$\phi 32$	STR2-O-32K	

Note: Specify the kit No. when placing an order.

Dimensions

Same as STR2_B^M Series (double acting/standard). Refer to page 582.

LCW
LCR
LCG
LCX
LCM
STM
STG
STS/STL
STR2
UCA2
ULK*
JSK/M2
JSG
JSC3/JSC4
USSD
UFCD
USC
JSB3
LMB
LML
HCM
HCA
LBC
CAC4
UCAC2
CAC-N
UCAC-N
RCC2
RCS
PCC
SHC
MCP
GLC
MFC
BBS
RRC
GRC
RV3*
NHS
HR
LN
Hand
Chuk
MecHnd/Chuk
ShkAbs
FJ
FK
SpdContr
Ending

Twin rod cylinder/double acting/fine speed

STR2-M_BF Series

● Bore size: φ10/φ16/φ20/φ25/φ32

JIS symbol



Specifications

Descriptions		STR2-MF (metal bush bearing), STR2-BF (ball bearing)				
Bore size	mm	φ10	φ16	φ20	φ25	φ32
Actuation		Double acting				
Working fluid		Compressed air				
Max. working pressure	MPa	0.70 (≈100 psi, 7 bar)				
Min. working pressure	MPa	0.15 (≈22 psi, 1.5 bar)		0.1 (≈15 psi, 1 bar)		
Ambient temperature	°C	5 (41°F) to 60 (140°F)				
Port size		M5				Rc1/8
Stroke tolerance	mm	0 to -5				
Working piston speed	mm/s	1 to 200				
Non-rotating accuracy (reference value)	STR2-MF	±0.3°			±0.2°	
	STR2-BF	±0.1°			±0.3°	
Piston rod bearing	STR2-MF	Metal bush bearing				
	STR2-BF	Ball bearing				
Cushion		Rubber cushion				
Lubrication		Lubrication not possible				
Allowable absorbed energy	J	0.061	0.181	0.303	0.68	1.3

* The low speed (STR2-0) is recommended for φ6.

Stroke length

Model No.	Bore size (mm)	Standard stroke length (mm)	Max. stroke length (mm)	Min. stroke length (mm)	Min. stroke with switch (mm)
STR2-M _B F	φ10	10, 20, 30, 40, 50	50	5	10
	φ16, φ20, φ25, φ32	10, 20, 30, 40, 50, 60, 70, 80, 90, 100	100		

*1: The custom stroke length is available in 1 mm increments. However, the total length is the same as that of the next longer standard stroke length.

Switch specifications

● 1-color/2-color display

Descriptions	Proximity 2-wire		Proximity 3-wire			Reed 2-wire			
	K2H/K2V	K2YH/K2YV	K3H/K3V	K3PH/K3PV (Custom order)	K3YH/K3YV	K0H/K0V		K5H/K5V	
Applications	Dedicated for programmable controller		For programmable controller, relay			For programmable controller, relay		For programmable controller, relay, IC circuit (without indicator lamp), serial connection	
Output method	-		NPN output	PNP output	NPN output	-			
Power supply voltage	-		10 to 28 VDC			-			
Load voltage	10 to 30 VDC		30 VDC or less			12 VDC/24 VDC	110 VAC	5/12/24 VDC	110 VAC
Load current	5 to 20 mA (*1)		50 mA or less			5 to 50 mA	7 to 20 mA	50 mA or less	20 mA or less
Indicator lamp	LED (Lit when ON)	Red/green LED (Lit when ON)	LED (Lit when ON)	Yellow LED (Lit when ON)	Red/green LED (Lit when ON)	LED (Lit when ON)		-	
Leakage current	1 mA or less		10 μA or less			0 mA			
Weight	1 m:18	1 m:31	1 m:18	1 m:31	1 m:18 3 m:49 5 m:80				
	3 m:49	3 m:85	3 m:49	3 m:85					
	5 m:80	5 m:139	5 m:80	5 m:139					

*1 : The above max. load current is 20 mA at 25°C. The current is lower than 20 mA if operating ambient temperature around the switch is higher than 25°C. (5 to 10 mA at 60°C)

*2 : Refer to Ending Page 1 for other switch specifications.

*3 : Dimensions depend on switch model No. Refer to Ending Page 21 for details.

Theoretical thrust table

(Unit: N)

Bore size (mm)	Operating direction	Working pressure MPa							
		0.1	0.15	0.2	0.3	0.4	0.5	0.6	0.7
φ10	Push	-	-	31.4	47.1	62.8	78.5	94.2	1.10×10 ²
	Pull	-	-	20.1	30.2	40.2	50.3	60.3	70.4
φ16	Push	40.2	60.3	80.4	1.21×10 ²	1.61×10 ²	2.01×10 ²	2.41×10 ²	2.81×10 ²
	Pull	24.5	36.8	49.0	73.5	98.0	1.23×10 ²	1.47×10 ²	1.72×10 ²
φ20	Push	62.8	94.2	1.26×10 ²	1.88×10 ²	2.51×10 ²	3.14×10 ²	3.77×10 ²	4.40×10 ²
	Pull	40.2	60.3	80.4	1.21×10 ²	1.61×10 ²	2.01×10 ²	2.41×10 ²	2.81×10 ²
φ25	Push	98.2	1.47×10 ²	1.96×10 ²	2.95×10 ²	3.93×10 ²	4.91×10 ²	5.89×10 ²	6.87×10 ²
	Pull	67.4	1.01×10 ²	1.35×10 ²	2.02×10 ²	2.70×10 ²	3.37×10 ²	4.04×10 ²	4.72×10 ²
φ32	Push	1.61×10 ²	2.41×10 ²	3.22×10 ²	4.83×10 ²	6.43×10 ²	8.04×10 ²	9.65×10 ²	1.13×10 ³
	Pull	1.21×10 ²	1.81×10 ²	2.41×10 ²	3.62×10 ²	4.83×10 ²	6.03×10 ²	7.24×10 ²	8.44×10 ²

How to order

- Without switch (built-in magnet for switch)



- With switch (built-in magnet for switch)

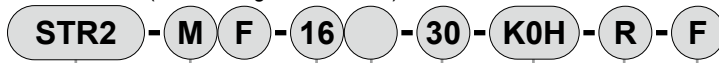

Model No. **A** Bearing

B Bore size

C Port thread

D Stroke length
*1

■ The custom stroke length is available in 1 mm increments. However, the total length is the same as that of the next longer standard stroke length.

E Switch model No.
*2

F Switch quantity

G Option

⚠ Precautions for model selection

*1 : The max stroke length of rear piping "R" is:

- φ16 : 70 stroke
- φ20/φ25 : 60 stroke
- φ32 : 50 stroke

*2 : STR2-BF-10 is not compatible with reed switch.

*3 : In the case of G thread, ports on the opposite side (option "O") are not available. Rather than plug sealing, they are simply not provided.

(The standard ports are not provided in the case of option "O".)

[Example of model No.]

STR2-MF-16-30-K0H-R-F

Model: Twin rod cylinder, fine speed

- A** Bearing : Metal bush bearing
- B** Bore size : φ16 mm
- C** Port thread : Rc thread
- D** Stroke length : 30 mm
- E** Switch model No.: Reed switch K0H, lead wire 1 m
- F** Switch quantity : 1 on rod side
- G** Option : End plate material: steel

How to order switch

- Switch body only



Switch model No.
(Item **E** above)

Code	Content					
A Bearing						
M	Metal bush bearing					
B	Ball bearing					
B Bore size (mm)						
10	φ10					
16	φ16					
20	φ20					
25	φ25					
32	φ32					
C Port thread						
Blank	Rc thread					
NN	NPT thread (φ32 only) (custom order product)					
GN *3	G thread (φ32 only) (custom order product)					
D Stroke length (mm)						
Bore size	Stroke length	Custom stroke length				
φ10	5 to 50	In 1 mm increments				
φ16	5 to 100					
φ20	5 to 100					
φ25	5 to 100					
φ32	5 to 100					
E Switch model No.						
Axial lead wire	Radial lead wire	Contact	Voltage		Display	Lead wire
			AC	DC		
K0H*	K0V*	Reed	●	●	1-color display	2-wire
			●	●	no indicator lamp	
K2H*	K2V*	Proximity		●	1-color	2-wire
				●	display	
K3PH*	K3PV*	Proximity		●	1-color display (custom)	3-wire
				●	2-color	
K2YH*	K2YV*	Proximity		●	display	3-wire
				●	display	
K3YH*	K3YV*	Proximity		●	display	3-wire
				●	display	
* Lead wire length						
Blank	1 m (standard)					
3	3 m (option)					
5	5 m (option)					
F Switch quantity						
R	1 on rod side					
H	1 on head side					
D	2					
G Option						
F	End plate material: steel					

Clean-room specifications (Catalog No. CB-033SA)

- Anti-dust generation structure for use in cleanrooms

STR2-B - - P7*

Dimensions

Same as STR2 Series (double acting/single rod). Refer to page 582.

Technical data

Refer to Measuring methods (in Pneumatic Cylinders I (Catalog No.CB-029SA) on page 1161), for technical data regarding measuring methods.

LCW
LCR
LCG
LCX
LCM
STM
STG
STS/STL
STR2
UCA2
ULK*
JSK/M2
JSG
JSC3/JSC4
USSD
UFCD
USC
JSB3
LMB
LML
HCM
HCA
LBC
CAC4
UCAC2
CAC-N
UCAC-N
RCC2
RCS
PCC
SHC
MCP
GLC
MFC
BBS
RRC
GRC
RV3*
NHS
HR
LN
Hand
Chuk
MecHnd/Chuk
ShkAbs
FJ
FK
SpdContr
Ending

LCW
LCR
LCG
LCX
LCM
STM
STG
STS/STL
STR2
UCA2
ULK*
JSK/M2
JSG
JSC3/JSC4
USSD
UFGD
USC
JSB3
LMB
LML
HCM
HCA
LBC
CAC4
UCAC2
CAC-N
UCAC-N
RCC2
RCS
PCC
SHC
MCP
GLC
MFC
BBS
RRC
GRC
RV3*
NHS
HR
LN
Hand
Chuk
MechHnd/Chuk
ShkAbs
FJ
FK
SpdContr
Ending

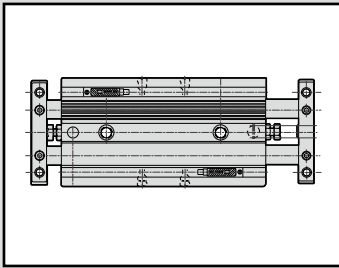

Twin rod cylinder/double acting/double rod

STR2-M_BD Series

● Bore size: φ6/φ10/φ16/φ20/φ25/φ32

JIS symbol



Specifications

Descriptions		STR2-MD (metal bush bearing)			STR2-BD (ball bearing)		
Bore size	mm	φ6	φ10	φ16	φ20	φ25	φ32
Actuation		Double acting/double rod					
Working fluid		Compressed air					
Max. working pressure	MPa	0.7 (≈100 psi, 7 bar)					
Min. working pressure	MPa	0.25 (≈36 psi, 2.5 bar)	0.2 (≈29 psi, 2 bar)	0.15 (≈22 psi, 1.5 bar)			
Proof pressure	MPa	1.05 (≈150 psi, 10.5 bar)					
Ambient temperature	°C	-10 (14°F) to 60 (140°F) (no freezing)					
Port size		M5					Rc1/8
Stroke tolerance	mm	+2.0 0					
Adjustable stroke range	mm	0 to -5					
Working piston speed	mm/s	50 to 500					
Non-rotating accuracy (reference value)	STR2-M	±0.4°	±0.3°			±0.2°	
	STR2-B	±0.2°	±0.1°			±0.3°	
Piston rod	STR2-M	Metal bush bearing					
Bearing	STR2-B	Ball bearing					
Cushion		Rubber cushion					
Lubrication		Not required (use turbine oil class 1 ISO VG32 if necessary for lubrication)					
Max absorbed energy J *1	PULL	0.059	0.083	0.083	0.127	0.237	0.311

*1: The allowable absorbed energy of the double rod is for the PULL only.

Stroke length

Bore size	Stroke length (mm)	Max. stroke length (mm)	Min. stroke length (mm)	Min. stroke with switch (mm)
φ6	10, 20, 30, 40, 50	50	5	10
φ10				
φ16	10, 20, 30, 40, 50	100		
φ20				
φ25				
φ25				
φ32				

Theoretical thrust table

(Unit: N)

Bore size (mm)	Working pressure MPa							
	0.1	0.15	0.2	0.3	0.4	0.5	0.6	0.7
φ6	-	-	6.28	9.42	12.6	15.7	18.8	22.0
φ10	-	-	20.1	30.2	40.2	50.3	60.3	70.4
φ16	24.5	36.8	49.0	73.5	98.0	1.23×10 ²	1.47×10 ²	1.72×10 ²
φ20	40.2	60.3	80.4	1.21×10 ²	1.61×10 ²	2.01×10 ²	2.41×10 ²	2.81×10 ²
φ25	67.4	1.01×10 ²	1.35×10 ²	2.02×10 ²	2.70×10 ²	3.37×10 ²	4.04×10 ²	4.72×10 ²
φ32	1.21×10 ²	1.81×10 ²	2.41×10 ²	3.62×10 ²	4.83×10 ²	6.03×10 ²	7.24×10 ²	8.44×10 ²

Switch specifications

- 1-color/2-color display

Descriptions	Proximity 2-wire		Proximity 3-wire			Reed 2-wire				
	K2H/K2V	K2YH/ K2YV	K3H/K3V	K3PH/K3PV (custom order)	K3YH/ K3YV	K0H/K0V		K5H/K5V		
Applications	Dedicated for programmable controller		For programmable controller, relay			For programmable controller, relay		For programmable controller, relay, IC circuit (without indicator lamp), serial connection		
Output method	-		NPN output	PNP output	NPN output	-				
Power supply voltage	-		10 to 28 VDC			-				
Load voltage	10 to 30 VDC		30 VDC or less			12 VDC/24 VDC	110 VAC	5/12/24 VDC	110 VAC	
Load current	5 to 20 mA (*1)		50 mA or less			5 to 50 mA	7 to 20 mA	50 mA or less	20 mA or less	
Indicator lamp	LED (Lit when ON)	Red/green LED (Lit when ON)	LED (Lit when ON)	Yellow LED (Lit when ON)	Red/green LED (Lit when ON)	LED (Lit when ON)		-		
Leakage current	1 mA or less		10 µA or less			0 mA				
Weight	g	1 m:18 3 m:49 5 m:80	1 m:31 3 m:85 5 m:139	1 m:18 3 m:49 5 m:80	1 m:31 3 m:85 5 m:139	1 m:18 3 m:49 5 m:80				

*1 : The above max. load current is 20 mA at 25°C. The current is lower than 20 mA if operating ambient temperature around the switch is higher than 25°C. (5 to 10 mA at 60°C)

*2 : Refer to Ending Page 1 for other switch specifications.

*3 : Dimensions depend on switch model No. Refer to Ending Page 21 for details.

Cylinder weight

Unit: g

Bore size	Product weight at 0 mm stroke		Additional weight per S = 10 mm
	STR2-M	STR2-B	
φ6	100	95	13
φ10	185	200	20
φ16	450	475	44
φ20	735	730	60
φ25	1160	1120	82
φ32	1960	2060	115

(Example) Product weight

STR2-MD-6-10-K2H-D

- Product weight for 0 mm stroke length ... 100 g
- Additional weight for stroke length 10 mm ... 13 x 1 = 13 g
- Weight of 2 cylinder switches ... 18 g x 2 = 36 g
- Product weight ... 100 g + 13 g + 36 g = 149 g

LCW
LCR
LCG
LCX
LCM
STM
STG
STS/STL
STR2
UCA2
ULK*
JSK/M2
JSG
JSC3/JSC4
USSD
UFCD
USC
JSB3
LMB
LML
HCM
HCA
LBC
CAC4
UCAC2
CAC-N
UCAC-N
RCC2
RCS
PCC
SHC
MCP
GLC
MFC
BBS
RRC
GRC
RV3*
NHS
HR
LN
Hand
Chuk
MecHnd/Chuk
ShkAbs
FJ
FK
SpdContr
Ending

STR2-MD Series

How to order

Without switch (built-in magnet for switch)

STR2 - (M) D - (16) - (30) - (O)

With switch (built-in magnet for switch)

STR2 - (M) D - (16) - (30) - (K0H) - (R) - (O)

Model No.

A Bearing

B Bore size

C Port thread

D Stroke length

Refer to page 604 for the min. stroke length.

E Switch model No.

*1

F Switch quantity

G Option

*2

⚠ Precautions for model No. selection

*1 : STR2-B-6 and 10 are not compatible with a reed switch.

*2 : The piping port positions for "O" are as shown in the figure below.

Piping port positions for standard (blank)

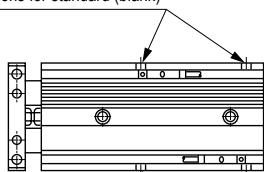

Piping port position on the 180° opposite side (code: 0)

*3 : In the case of G thread, ports on the opposite side (option "O") are not available. Rather than plug sealing, they are simply not provided. (The standard ports are not provided in the case of option "O".)

[Example of model No.]

STR2-MD-16-30-K0H-R-O

Model: Twin rod cylinder, double rod

- A** Bearing : Metal bush bearing
- B** Bore size : φ16 mm
- C** Port thread : Rc thread
- D** Stroke length : 30 mm
- E** Switch model No.: Reed K0H switch
- F** Switch quantity : 1 on rod side
- G** Option : Piping port position on the 180° opposite side

Code	Content				
A Bearing					
M	Metal bush bearing				
B	Ball bearing				
B Bore size (mm)					
6	φ6				
10	φ10				
16	φ16				
20	φ20				
25	φ25				
32	φ32				
C Port thread					
Blank	Rc thread				
NN	NPT thread (φ32 only) (custom order product)				
GN	G thread (φ32 only) (custom order product) *3				
D Stroke length (mm)					
10	10	φ6 to φ32			
20	20				
30	30				
40	40				
50	50				
60	60	φ16 to φ32			
70	70				
80	80				
90	90				
100	100				
E Switch model No.					
Axial lead wire	Radial lead wire	Contact	Voltage AC DC	Indicator	Lead wire
K0H*	K0V*	Reed	● ●	1-color display	2-wire
K5H*	K5V*		● ●	Without indicator lamp	
K2H*	K2V*	Proximity	● ●	1-color display	2-wire
K3H*	K3V*		● ●	1-color display (custom)	3-wire
K3PH*	K3PV*		● ●	2-color display	2-wire
K2YH*	K2YV*		● ●	2-color display	3-wire
K3YH*	K3YV*		● ●		
* Lead wire length					
Blank	1 m (standard)				
3	3 m (option)				
5	5 m (option)				
F Switch quantity					
R	1 on rod side				
H	1 on head side				
D	2				
G Option					
F	End plate material: steel				
O	Piping port position on the 180° opposite side				

How to order switch

SW - K0H*

Switch model No.
(Item **E** above)

Internal structure and parts list (metal bush bearing)

- Double rod

STR2-MD

- Piping port position on the 180° opposite side

STR2-MD ... -O

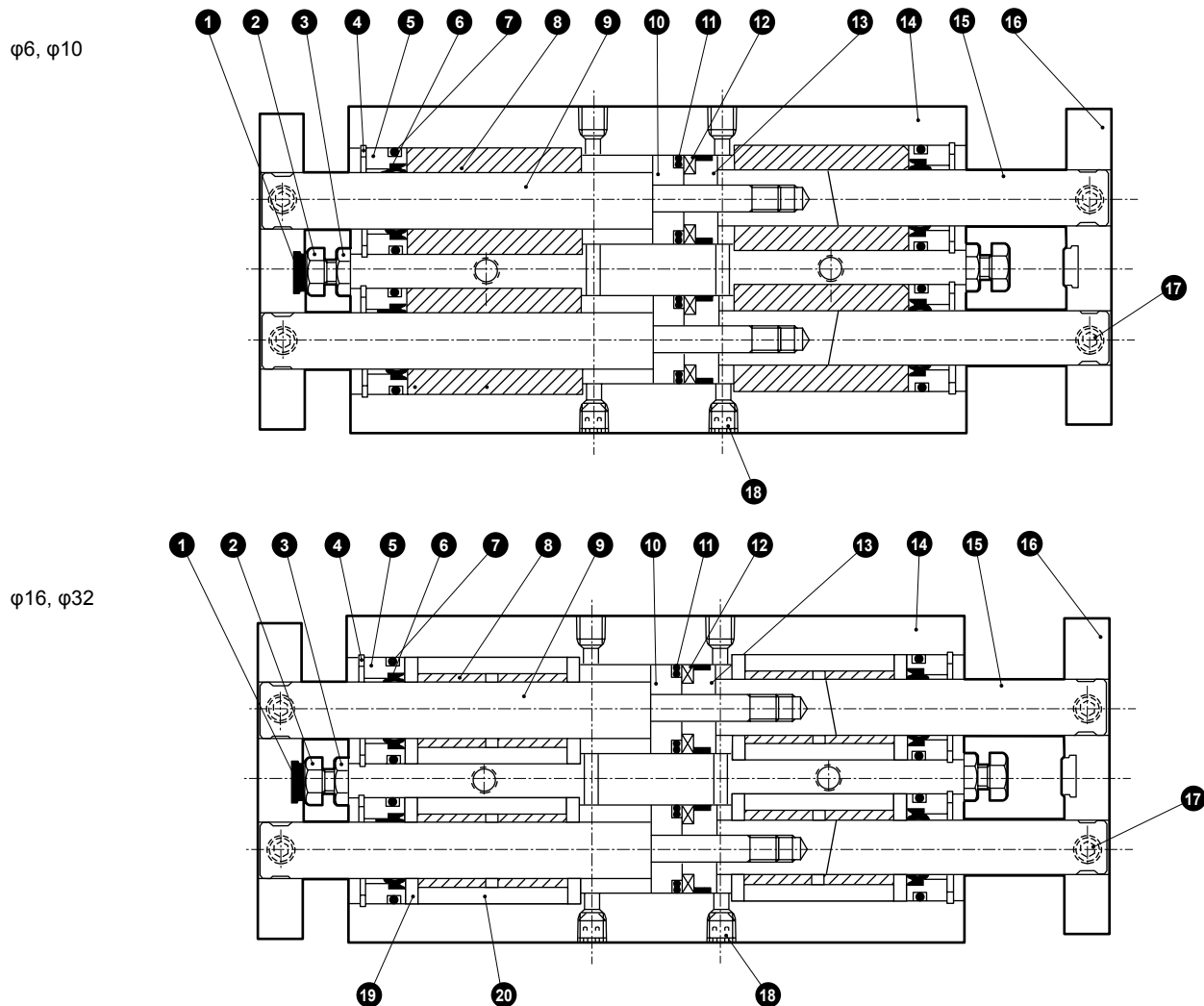

No.	Part name	Material	Remarks	No.	Part name	Material	Remarks
1	Cushion rubber (H)	Urethane rubber		11	Piston packing	Nitrile rubber	
2	Hexagon head bolt	Stainless steel		12	Magnet	Plastic	
3	Hexagon nut	Stainless steel		13	Spacer	Aluminum alloy	Chromate
4	Snap ring for hole	Stainless steel		14	Cylinder body	Aluminum alloy	Hard alumite
5	Housing	Aluminum alloy	Chromate	15	Piston rod (B)	Stainless steel (φ6 to φ20) Steel (φ25, φ32)	Industrial chrome plating (φ16 to φ32)
6	Rod packing	Nitrile rubber		16	End plate	Aluminum alloy	Alumite
7	O-ring	Nitrile rubber		17	Hexagon socket set screw	Stainless steel	
8	Bush	Copper alloy		18	Hexagon socket set screw	Stainless steel	
9	Piston rod (A)	Stainless steel (φ6 to φ20) Steel (φ25, φ32)	Industrial chrome plating (φ16 to φ32)	19	Spacer (φ16 to φ32)	Aluminum alloy	Chromate
10	Piston	Aluminum alloy	Chromate	20	Aluminum housing	Aluminum alloy	Chromate

Repair parts list

Bore size (mm)	Kit No.	Repair parts No.
φ 6	STR2-D-6K	
φ10	STR2-D-10K	
φ16	STR2-D-16K	● 1 ● 6 ● 7
φ20	STR2-D-20K	
φ25	STR2-D-25K	● 11
φ32	STR2-D-32K	

Note: Specify the kit No. when placing an order.

LCW
LCR
LCG
LCX
LCM
STM
STG
STS/STL
STR2
UCA2
ULK*
JSK/M2
JSG
JSC3/JSC4
USSD
UFCD
USC
JSB3
LMB
LML
HCM
HCA
LBC
CAC4
UCAC2
CAC-N
UCAC-N
RCC2
RCS
PCC
SHC
MCP
GLC
MFC
BBS
RRC
GRC
RV3*
NHS
HR
LN
Hand
Chuk
MecHnd/Chuk
ShkAbs
FJ
FK
SpdContr
Ending

STR2-BD Series

- LCW
- LCR
- LCG
- LCX
- LCM
- STM
- STG
- STS/STL
- STR2**
- UCA2
- ULK*
- JSK/M2
- JSG
- JSC3/JSC4
- USSD
- UFCD
- USC
- JSB3
- LMB
- LML
- HCM
- HCA
- LBC
- CAC4
- UCAC2
- CAC-N
- UCAC-N
- RCC2
- RCS
- PCC
- SHC
- MCP
- GLC
- MFC
- BBS
- RRC
- GRC
- RV3*
- NHS
- HR
- LN
- Hand
- Chuk
- MecHnd/Chuk
- ShkAbs
- FJ
- FK
- SpdContr
- Ending

Internal structure and parts list (ball bearing)

- Double rod
- STR2-BD**
- Piping port position on the 180° opposite side
- STR2-BD ... -O**

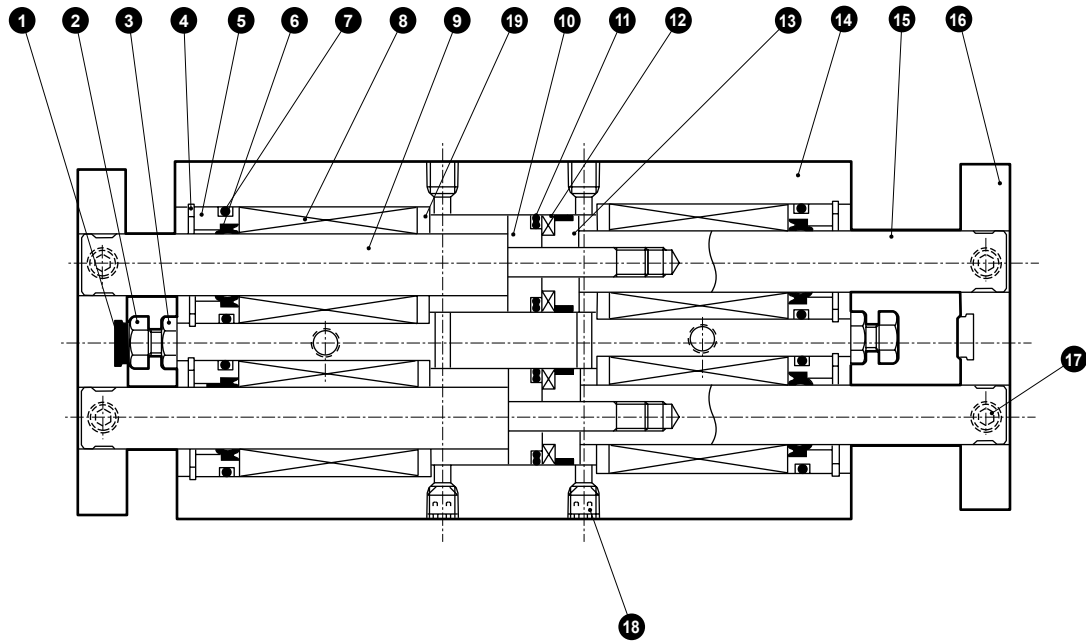

No.	Part name	Material	Remarks	No.	Part name	Material	Remarks
1	Cushion rubber (H)	Urethane rubber		10	Piston	Aluminum alloy	Chromate
2	Hexagon head bolt	Stainless steel		11	Piston packing	Nitrile rubber	
3	Hexagon nut	Stainless steel		12	Magnet	Plastic	
4	Snap ring for hole	Stainless steel		13	Spacer	Aluminum alloy	Chromate
5	Housing	Stainless steel (φ6, φ10) Aluminum alloy (φ16 to φ32)	Chromate	14	Cylinder body	Aluminum alloy	Hard alumite
6	Rod packing	Nitrile rubber		15	Piston rod (B)	Steel	Industrial chrome plating
7	O-ring	Nitrile rubber		16	End plate	Aluminum alloy	Alumite
8	Bearing			17	Hexagon socket set screw	Stainless steel	
9	Piston rod (A)	Steel	Industrial chrome plating	18	Hexagon socket set screw	Stainless steel	
				19	Spacer	Aluminum alloy	Chromate

Repair parts list

Bore size (mm)	Kit No.	Repair parts No.
φ 6	STR2-D-6K	
φ10	STR2-D-10K	
φ16	STR2-D-16K	1 6 7
φ20	STR2-D-20K	11
φ25	STR2-D-25K	
φ32	STR2-D-32K	

Note: Specify the kit No. when placing an order.

Dimensions (φ6 to φ32)



- Double rod (D), piping port position on the 180° opposite side (O)

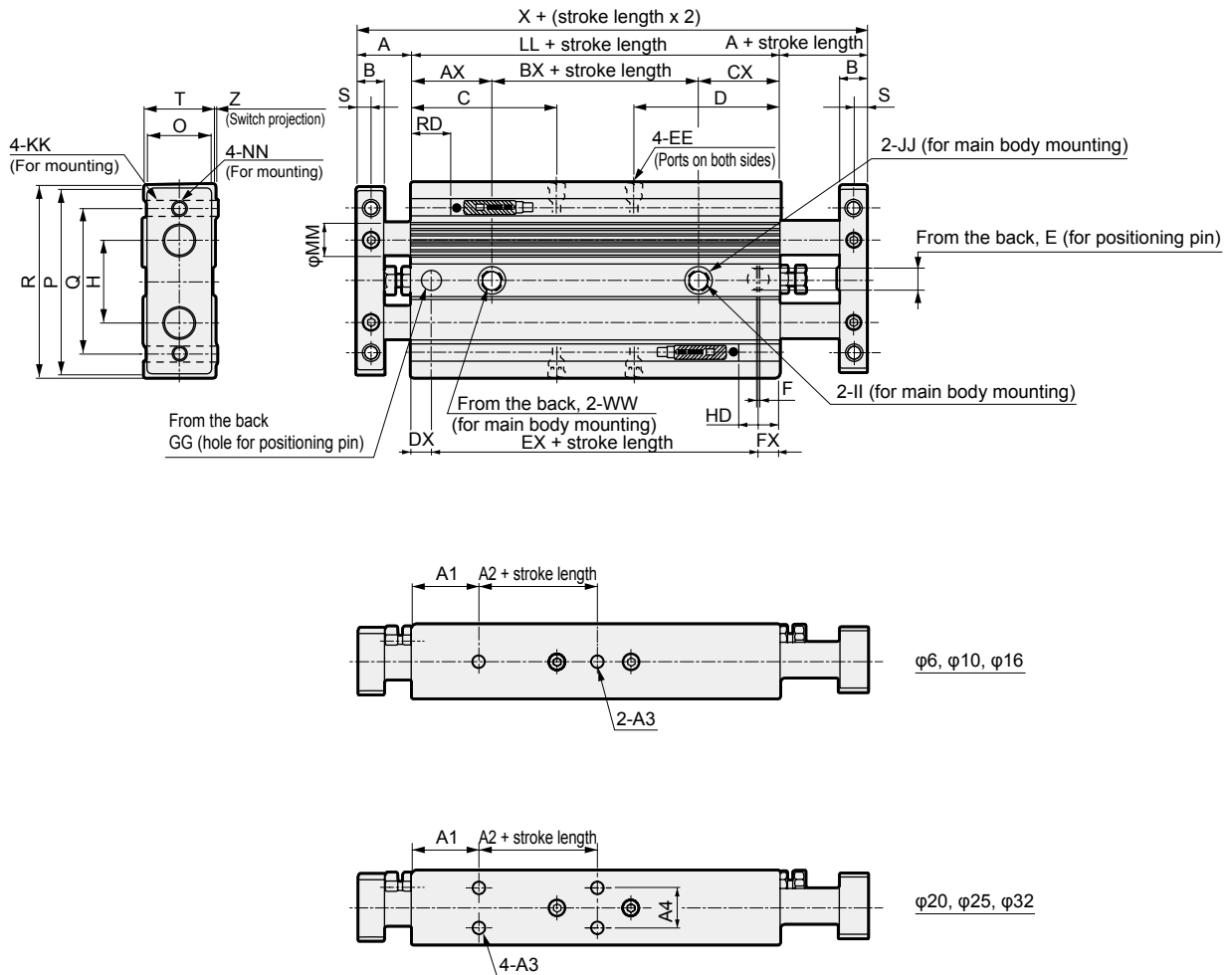

- *1 : HD and RD dimensions for 10 mm stroke length differ from these dimensions according to the setting.
- *2 : Refer to page 611 for HD, RD and protruding dimensions of the 2-color display switch.
- *3 : STR2-B-6 and 10 are not compatible with K0 and K5 reed switches.
- *4 : The cylinder may tilt due to the uneven surface if it is installed with the spot face side (JJ) contacted. In this case, change the port position or use the option of piping port position on the 180° opposite side (O) to keep the spot face side from being the contacting surface.

Code	Basic dimensions																
Bore size (mm)	A	B	C	D	E	EE	F	GG	H	II	JJ	KK	LL	MM	NN	O	P
φ 6	12	6	24.5	24.5	4 ^{+0.07} _{-0.02} depth 4	M5	1	4 ^{+0.07} _{-0.02} depth 4	14	3.4	6.5 spot face depth 3.3	M3 through	61	4	M3 through	11	34
φ10	14	6	35	35	4 ^{+0.07} _{-0.02} depth 4	M5	1	4 ^{+0.07} _{-0.02} depth 4	20	4.3	8 spot face depth 4.4	M4 through	82.5	6	M4 through	13	42
φ16	16	8	43	43	6 ^{+0.07} _{-0.02} depth 6	M5	1	6 ^{+0.07} _{-0.02} depth 6	25	4.3	8 spot face depth 4.4	M5 through	99	10	M5 through	19	52
φ20	20	10	46	46	6 ^{+0.07} _{-0.02} depth 6	M5	1	6 ^{+0.07} _{-0.02} depth 6	28	5.2	9.5 spot face depth 5.4	M5 through	108	12	M5 through	24	60
φ25	22	12	44	44	6 ^{+0.07} _{-0.02} depth 6	M5	1	6 ^{+0.07} _{-0.02} depth 6	34	6.3	11 spot face depth 6.5	M6 through	108	14	M6 through	30	70
φ32	22	12	56	56	6 ^{+0.07} _{-0.02} depth 6	Rc 1/8	1	6 ^{+0.07} _{-0.02} depth 6	44	6.3	11 spot face depth 6.5	M6 through	133	16	M6 through	36	94

Code															K0/K5/K2/K3				
Bore size (mm)	Q	R	S	T	WW	X	AX	BX	CX	DX	EX	FX	Z	A1	A2	A3	A4	HD	RD
φ 6	29	36	3	13	M4 depth 5	85	20	21	20	7	47	7	1.0	15	10	M3 depth 4	-	20.5 *1	21 *1
φ10	36	44	3	15	M5 depth 6	110.5	24	34.5	24	8	65.5	9	1.0	15	20	M3 depth 3.5	-	30.5 *1	32.5 *1
φ16	45	58	4	21	M5 depth 6	131	24	51	24	8	83	8	0.5	20	25	M4 depth 4	-	39	40.5
φ20	50	62	5	27	M6 depth 8	148	24	60	24	9	90	9	0.5	20	30	M4 depth 4	13	43	45
φ25	60	72	6	33	M8 depth 8	152	24	60	24	9	90	9	0.5	20	30	M5 depth 6	18	43.5	44.5
φ32	75	96	6	38	M8 depth 8	177	24	85	24	9	115	9	0.5	20	40	M5 depth 8	24	55.5	57.5

- LCW
- LCR
- LCG
- LCX
- LCM
- STM
- STG
- STS/STL
- STR2**
- UCA2
- ULK*
- JSK/M2
- JSG
- JSC3/JSC4
- USSD
- UFCD
- USC
- JSB3
- LMB
- LML
- HCM
- HCA
- LBC
- CAC4
- UCAC2
- CAC-N
- UCAC-N
- RCC2
- RCS
- PCC
- SHC
- MCP
- GLC
- MFC
- BBS
- RRC
- GRC
- RV3*
- NHS
- HR
- LN
- Hand
- Chuk
- MecHnd/Chuk
- ShkAbs
- FJ
- FK
- SpdContr
- Ending

STR2-M Series

- LCW
- LCR
- LCG
- LCX
- LCM
- STM
- STG
- STS/STL
- STR2**
- UCA2
- ULK*
- JSK/M2
- JSG
- JSC3/JSC4
- USSD
- UFCD
- USC
- JSB3
- LMB
- LML
- HCM
- HCA
- LBC
- CAC4
- UCAC2
- CAC-N
- UCAC-N
- RCC2
- RCS
- PCC
- SHC
- MCP
- GLC
- MFC
- BBS
- RRC
- GRC
- RV3*
- NHS
- HR
- LN
- Hand
- Chuk
- MecHnd/Chuk
- ShkAbs
- FJ
- FK
- SpdContr
- Ending

STR2 Series with switch common dimensions (2-color display switch)

- Standard, low speed (O), position locking (Q), fine speed (F), end plate material: steel (F)
rear piping (R), copper and PTFE free (P6), piping port position on the 180° opposite side (O)

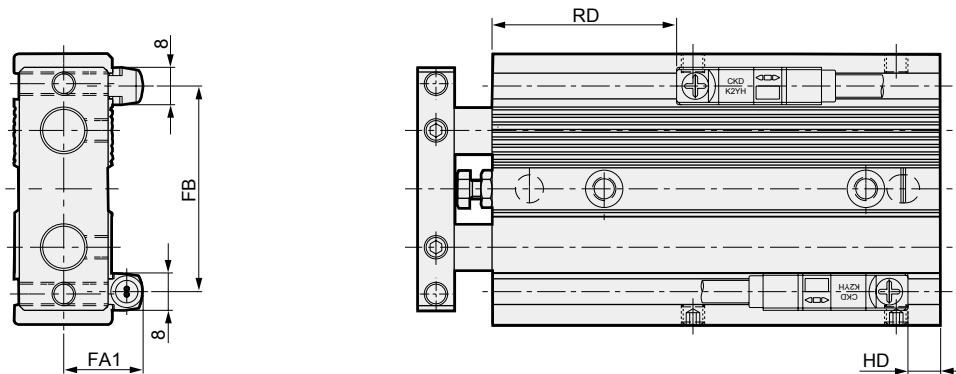

- 2-color display K□YH/V

Code	FA	FB	RD				HD			
			STR2-M-B STR2-M-B-O STR2-M-B-F STR2-M-B-P6 STR2-M-B-O	STR2-M-B-R	STR2-M-B-Q-H	STR2-M-B-Q-R	STR2-M-B STR2-M-B-O STR2-M-B-F STR2-M-B-P6 STR2-M-B-O	STR2-M-B-R	STR2-M-B-Q-H	STR2-M-B-Q-R
φ6	13.5	24	20	20	-	-	2.5	12.5	-	-
φ10	14.5	34	32	32	-	-	1	11	-	-
φ16	17	44	38.5	38.5	38.5	68.5	5.5	15.5	35.5	5.5
φ20	20	49	44	44	44	74	9.5	19.5	39.5	9.5
φ25	23	58	42.5	42.5	42.5	72.5	10.5	20.5	40.5	10.5
φ32	25.5	71	54.5	54.5	54.5	84.5	14.5	24.5	44.5	14.5

STR2 Series with switch common dimensions (2-color display switch)

- Double rod (D)

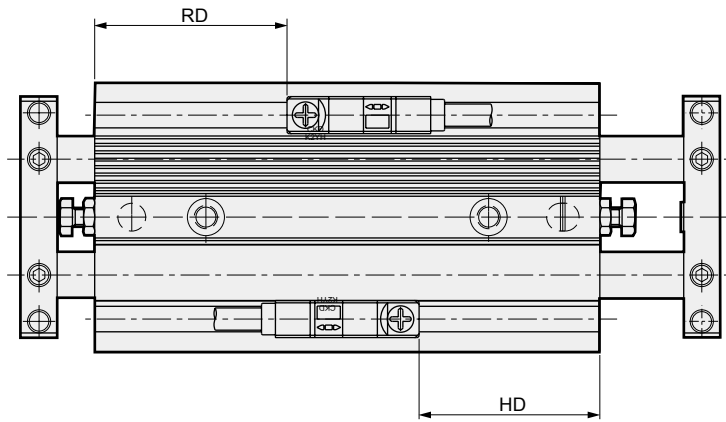
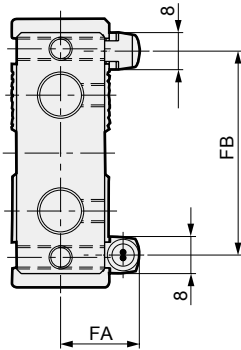

- 2-color display K□YH/V

Code	FA	FB	RD	HD
φ6	13.5	24	20	19.5
φ10	14.5	34	31	29
φ16	17	44	39	38
φ20	20	49	44	42
φ25	23	58	43.5	42.5
φ32	25.5	71	56.5	54.5

- LCW
- LCR
- LCG
- LCX
- LCM
- STM
- STG
- STS/STL
- STR2**
- UCA2
- ULK*
- JSK/M2
- JSG
- JSC3/JSC4
- USSD
- UFCD
- USC
- JSB3
- LMB
- LML
- HCM
- HCA
- LBC
- CAC4
- UCAC2
- CAC-N
- UCAC-N
- RCC2
- RCS
- PCC
- SHC
- MCP
- GLC
- MFC
- BBS
- RRC
- GRC
- RV3*
- NHS
- HR
- LN
- Hand
- Chuk
- MecHnd/Chuk
- ShkAbs
- FJ
- FK
- SpdContr
- Ending