

Magnet rodless cylinder

- Basic (guide combined) **MRL2-(F) Series**
- Simplified guide 1-piston **MRL2-G(F) Series**
- Simplified guide 2-piston **MRL2-W(F) Series**

● Bore size: $\phi 6$, $\phi 10$, $\phi 16$, $\phi 20$, $\phi 25$, $\phi 32$
 JIS symbol



Specifications

Descriptions	MRL2(L,F) , MRL2-G(L,F) , MRL2-W(L,F)						
Bore size	mm	$\phi 6$	$\phi 10$	$\phi 16$	$\phi 20$	$\phi 25$	$\phi 32$
Actuation		Double acting					
Working fluid		Compressed air					
Max. working pressure	MPa	0.7 (≈ 100 psi, 7 bar)					
Min. working pressure	MPa	0.3 (≈ 44 psi, 3 bar) (*1)			0.2 (≈ 29 psi, 2 bar)		
Proof pressure	MPa	1.05 (≈ 150 psi, 10.5 bar)					
Ambient temperature	$^{\circ}\text{C}$	-10 (14 $^{\circ}\text{F}$) to 60 (140 $^{\circ}\text{F}$) (fine speed: 5 (41 $^{\circ}\text{F}$) to 60 (140 $^{\circ}\text{F}$)) (no freezing)					
Port size		M5				Rc1/8	
Stroke tolerance	mm	+1.5 0 (to 1000)			+2.0 0 (to 1500)		
Working piston speed	mm/s	50 to 500 (fine speed: 1 to 200)					
Cushion		Rubber cushion					
Lubrication		Not required (use turbine oil ISO VG32 if necessary for lubrication); However, not available with fine speed					
Magnet holding force (*2)	N	19	63	166	294	350	574
Adjustable stroke range (single side) (*3)	mm	3	4	6	8.5	10	10

*1: The value for MRL2-G-6-C (with shock absorber) is 0.4.

*2: The simplified guide 2-piston (W) will be a 2-fold value.

*3: The stroke length of MRL2 (basic) cannot be adjusted.

Stroke length

Bore size (mm)	Standard stroke length (mm)	Max. stroke length (mm)	Max. stroke with switch (mm)	Max. stroke length (mm) of common piping with switch	Max. stroke length of fine speed (mm)	Min. stroke length (mm)
$\phi 6$	50, 100, 150, 200	300	200	-	300	1
$\phi 10$	50, 100, 150, 200, 250, 300	500	300	300	500	
$\phi 16$	100, 150, 200, 250, 300, 400, 500	1000	500	500	800	
$\phi 20$	200, 250, 300, 350, 400, 500, 600, 700	1500	700	700	800	
$\phi 25$	200, 250, 300, 350, 400, 500, 600, 700	1500	700	700	800	
$\phi 32$	200, 250, 300, 350, 400, 500, 600, 700	1500	700	700	700	

■ The custom stroke length is available in 1 mm increments.

Number of installed T type switches and min. stroke length (mm)

Switch quantity	1				2				3				4			
Switch model No.	T*V	T*H	T*YV	T*YH	T*V	T*H	T*YV	T*YH	T*V	T*H	T*YV	T*YH	T*V	T*H	T*YV	T*YH
Bore size (mm)																
$\phi 6$ or equiv.	5	5	5	5	20	50	40	70	40	85	71	115	60	120	101	160
$\phi 10$ or equiv.	5	5	5	5	20	50	40	70	40	85	71	115	60	120	101	160
$\phi 16$ or equiv.	5	5	5	5	20	50	40	70	40	85	71	115	60	120	101	160
$\phi 20$ or equiv.	5	5	5	5	20	50	40	70	40	85	71	115	60	120	101	160
$\phi 25$ or equiv.	5	5	5	5	20	50	40	70	40	85	71	115	60	120	101	160
$\phi 32$ or equiv.	5	5	5	5	20	50	40	70	40	85	71	115	60	120	101	160

Switch specifications

- 1-color/2-color display

Descriptions	Proximity 2-wire				Proximity 3-wire			
	T1H/T1V	T2H/T2V	T2YH/T2YV	T2WH/T2WV	T3H/T3V	T3PH/T3PV (custom order)	T3YH/T3YV	T3WH/T3WV
Applications	For programmable controller, relay, compact solenoid valve		Dedicated for programmable controller		For programmable controller, relay			
Output method	-				NPN output	PNP output	NPN output	NPN output
Power supply voltage	-				10 to 28 VDC			
Load voltage	85 to 265 VAC	10 to 30 VDC		24 VDC ±10%	30 VDC or less			
Load current	5 to 100 mA	5 to 20 mA (*2)			100 mA or less		50 mA or less	
Indicator lamp	LED (Lit when ON)	LED (Lit when ON)	Red/green LED (Lit when ON)	Red/green LED (Lit when ON)	LED (Lit when ON)	Yellow LED (Lit when ON)	Red/green LED (Lit when ON)	Red/green LED (Lit when ON)
Leakage current	1 mA or less with 100 VAC, 2 mA or less with 200 VAC		1 mA or less		10 µA or less			
Weight	g	1 m:33 3 m:87 5 m:142	1 m:18 3 m:49 5 m:80	1 m:33 3 m:87 5 m:142	1 m:18 3 m:49 5 m:80	1 m:18 3 m:49 5 m:80	1 m:33 3 m:87 5 m:142	1 m:18 3 m:49 5 m:80

*1: Refer to Ending Page 1 for other switch specifications.

*2: The above max. load current is 20 mA at 25°C. The current will be lower than 20 mA when operating ambient temperature around the switch is higher than 25°C. (5 to 10 mA at 60°C)

*3: Dimensions depend on switch model No. Refer to Ending Page 18 for details.

Cylinder weight

Unit (g)

Model No.	Without switch		With switch		Common piping with switch	
	Weight for 0 mm stroke length	Additional weight per S = 100mm	Weight for 0 mm stroke length	Additional weight per S = 100mm	Weight for 0 mm stroke length	Additional weight per S = 100mm
MRL2-6	73	13	103	39	-	-
MRL2-10	143	28	169	48	-	-
MRL2-16	278	43	313	63	-	-
MRL2-20	542	85	587	105	-	-
MRL2-25	954	98	1017	128	-	-
MRL2-32	1230	195	1301	225	-	-
MRL2-G-6	193	28	223	54	-	-
MRL2-G-10	368	53	394	73	411	94
MRL2-G-16	635	85	670	105	691	126
MRL2-G-20	1197	155	1242	175	1269	196
MRL2-G-25	1852	196	1915	226	1997	289
MRL2-G-32	2297	390	2368	420	2455	483
MRL2-W-6	203	28	233	54	-	-
MRL2-W-10	398	53	424	73	441	94
MRL2-W-16	710	85	745	105	766	126
MRL2-W-20	1367	155	1412	175	1439	196
MRL2-W-25	2206	196	2269	226	2351	289
MRL2-W-32	2859	390	2930	420	3017	483

*1: The weight of the switch is not included in the product weight of types with switch and common piping with switch.

Theoretical thrust table

- MRL2, MRL2-G

(Unit: N)

Bore size (mm)	Operating direction	Working pressure MPa					
		0.2	0.3	0.4	0.5	0.6	0.7
φ6	Push/Pull	-	8.48	11.3	14.1	17.0	19.8
φ10	Push/Pull	-	23.6	31.4	39.3	47.1	55.0
φ16	Push/Pull	40.2	60.3	80.4	1.01 × 10 ²	1.21 × 10 ²	1.41 × 10 ²
φ20	Push/Pull	62.8	94.2	1.26 × 10 ²	1.57 × 10 ²	1.88 × 10 ²	2.20 × 10 ²
φ25	Push/Pull	98.2	1.47 × 10 ²	1.96 × 10 ²	2.45 × 10 ²	2.95 × 10 ²	3.44 × 10 ²
φ32	Push/Pull	1.61 × 10 ²	2.41 × 10 ²	3.22 × 10 ²	4.02 × 10 ²	4.83 × 10 ²	5.63 × 10 ²

- MRL2-W

(Unit: N)

Bore size (mm)	Operating direction	Working pressure MPa					
		0.2	0.3	0.4	0.5	0.6	0.7
φ6	Push/Pull	-	17.0	22.6	28.3	33.9	39.6
φ10	Push/Pull	-	47.1	62.8	78.5	94.2	1.10 × 10 ²
φ16	Push/Pull	80.4	1.21 × 10 ²	1.61 × 10 ²	2.01 × 10 ²	2.41 × 10 ²	2.81 × 10 ²
φ20	Push/Pull	1.26 × 10 ²	1.88 × 10 ²	2.51 × 10 ²	3.14 × 10 ²	3.77 × 10 ²	4.40 × 10 ²
φ25	Push/Pull	1.96 × 10 ²	2.95 × 10 ²	3.93 × 10 ²	4.91 × 10 ²	5.89 × 10 ²	6.87 × 10 ²
φ32	Push/Pull	3.22 × 10 ²	4.83 × 10 ²	6.43 × 10 ²	8.04 × 10 ²	9.65 × 10 ²	1.13 × 10 ³

- SCP*3
- CMK2
- CMA2
- SCM
- SCG
- SCA2
- SCS2
- CKV2
- CAV2/COVP/N2
- SSD2
- SSG
- SSD
- CAT
- MDC2
- MVC
- SMG
- MSD/MSDG
- FC*
- STK
- SRL3
- SRG3
- SRM3
- SRT3
- MRL2
- MRG2
- SM-25
- ShkAbs
- FJ
- FK
- Spd Contr
- Ending

MRL2/MRL2-G Series

How to order

Without switch (without magnet for switch)

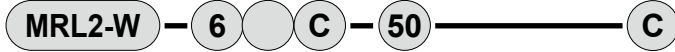

With switch (built-in magnet for switch)

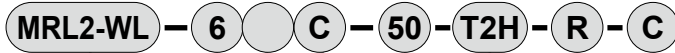

A Model No.

B Bore size

C Port thread
*1

D Cushion
*2

E Stroke length
*3

F Switch model No.

* indicates the lead wire length.
*5

G Switch quantity

H Option
*6

⚠ Precautions for model No. selection

*1 : When the cushion is a rubber cushion (blank), the port thread will be the following.
NPT thread: NN G thread: GN

*2 : In the case of MRL2-G and W with the "C" rubber-air cushion, the stopper protrudes from the end plate by approximately 1 mm at shipment. Note that the rubber-air cushion may not function if the stopper is moved to adjust the stroke length.

*3 : Refer to the following table for max. stroke length with switch.

*4 : Refer to page 1722 for min. stroke length with switch and max. stroke length for fine speed.

*5 : Switches other than **F** Switch model No. are also available. (Custom order) Refer to Ending Page 1 for details.

*6 : When selecting a common piping with "R" switch, select the model No. with a switch (MRL2-L).

Bore size (mm)	Max. stroke length with switch (mm)
φ6	200
φ10	300
φ16	500
φ20	700
φ25	700
φ32	700

[Example of model No.]

MRL2-WL-10-50-T2H-R-C

Model: Rodless cylinder

- A** Model No. : Simplified guide 2-piston
- B** Bore size : φ10 mm
- C** Port thread : Rc thread
- D** Cushion : Rubber cushion
- E** Stroke length : 50 mm
- F** Switch model No. : Proximity switch T2H
- G** Switch quantity : 1 on R side
- H** Option : With shock absorber

Code	Content	
A Model No.		
Basic	MRL2	Without switch
	MRL2-L	With switch
	MRL2-F	Fine speed
	MRL2-LF	Fine speed, with switch
Simplified guide 1-piston	MRL2-G	Without switch
	MRL2-GL	With switch
	MRL2-GF	Fine speed
Simplified guide 2-piston	MRL2-W	Without switch
	MRL2-WL	With switch
	MRL2-WF	Fine speed
	MRL2-WLF	Fine speed, with switch

B Bore size (mm)	
6	φ6
10	φ10
16	φ16
20	φ20
25	φ25
32	φ32

C Port thread	
Blank	Rc thread
N	NPT thread (φ25 and over) (custom order product)
G	G thread (φ25 and over) (custom order product)

D Cushion	
Blank	Rubber cushion
C	Rubber-air cushion

E Stroke length (mm)		
Bore size	Stroke length *4	Custom stroke length
φ6	1 to 300	In 1 mm increments
φ10	1 to 500	
φ16	1 to 1000	
φ20 to φ32	1 to 1500	

F Switch model No.						
Axial lead wire	Radial lead wire	Contact	Voltage		Display	Lead wire
			AC	DC		
T1H*	T1V*	Proximity	●		1-color display	2-wire
T2H*	T2V*			●		
T3H*	T3V*			●		2-color display
T2WH*	T2WV*			●	2-wire	
T2YH*	T2YV*			●		
T3WH*	T3WV*			●	3-wire	
T3YH*	T3YV*		●			
T3PH*	T3PV*		●	1-color display (custom)		

* Lead wire length	
Blank	1 m (standard)
3	3 m (option)
5	5 m (option)

G Switch quantity	
R	1 on R side
L	1 on L side
D	2
T	3
4	4 (when there are more than 4 switches, indicate switch quantity.)

H Option	
C	With shock absorber (basic cannot be selected.)
S	With scraper (fine speed cannot be selected)
R	Common piping with switch (basic and φ6 cannot be selected.)

How to order switch

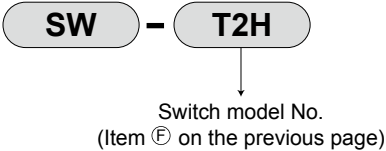

How to order discrete shock absorber

Used when changing from the standard to that with a shock absorber

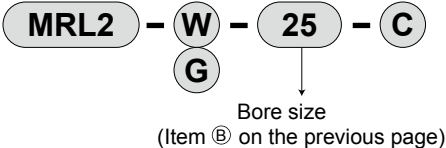

· Shock absorber and mounting nut (hexagon nut) set of 1 each.

(Reference)

Applicable shock absorber model No.

Model	Shock absorber model No.
MRL2-W-6, MRL2-G-6	NCK-00-0.1
MRL2-W-10, MRL2-G-10	NCK-00-0.1-C
MRL2-W-16, MRL2-G-16	NCK-00-0.3-C
MRL2-W-20, MRL2-G-20	NCK-00-0.7-C
MRL2-W-25, MRL2-G-25	NCK-00-1.2-C
MRL2-W-32, MRL2-G-32	NCK-00-1.2-C

Clean-room specifications (Catalog No. CB-033SA)

- Anti-dust generation structure for use in cleanrooms

MRL2 - * - - P72

MRL2 - * - - P52

Specifications for rechargeable battery (Catalog No. CC-1226A)

- Design compatible with rechargeable battery manufacturing process

MRL2 - - P4*

- SCP*3
- CMK2
- CMA2
- SCM
- SCG
- SCA2
- SCS2
- CKV2
- CAV2/COVP/N2
- SSD2
- SSG
- SSD
- CAT
- MDC2
- MVC
- SMG
- MSD/MSDG
- FC*
- STK
- SRL3
- SRG3
- SRM3
- SRT3
- MRL2**
- MRG2
- SM-25
- ShkAbs
- FJ
- FK
- Spd Contr
- Ending

Internal structure and parts list MRL2 (basic)

● MRL2 (basic)

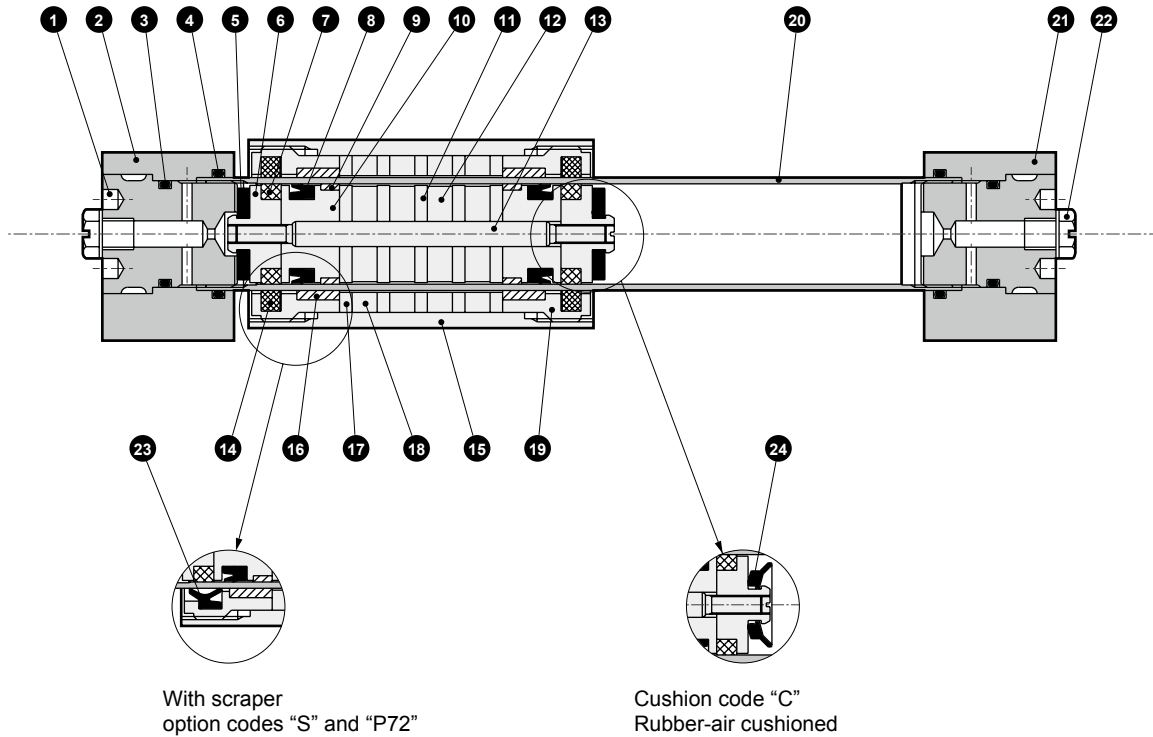

Cannot be disassembled

Parts list

No.	Part name	Material	Remarks	No.	Part name	Material	Remarks
1	End cap	Aluminum alloy	Chromate	13	Piston shaft	Stainless steel	
2	End plate (L)	Aluminum alloy	Alumite	14	Lube keeping structure (for slider)	Special rubber	None with P72
3	O-ring	Nitrile rubber		15	Slider	Aluminum alloy	Alumite
4	O-ring	Nitrile rubber		16	Slider wear ring	Polyacetal resin	
5	Cushion rubber	Urethane rubber		17	Slider yoke	Steel	Zinc chromate
6	Piston (2)	Aluminum alloy	Chromate	18	Magnet	Special alloy	
7	Lube keeping structure (for piston)	Special rubber		19	Slider cover	Aluminum alloy	Chromate
8	Piston packing	Nitrile rubber		20	Cylinder tube	Stainless steel	
9	Piston wear ring	Polyacetal resin		21	End plate (R)	Aluminum alloy	Alumite
10	Piston (1)	Aluminum alloy	Chromate	22	Plug	Copper alloy or steel	
11	Piston yoke	Steel	Zinc chromate	23	Scraper	Urethane rubber	
12	Magnet	Special alloy		24	Rubber-air cushion	Special rubber	

Note: The magnetic strength of the embedded magnet is powerful. Do not disassemble.

Internal structure and parts list MRL2 (basic)

● MRL2-L (with switch)

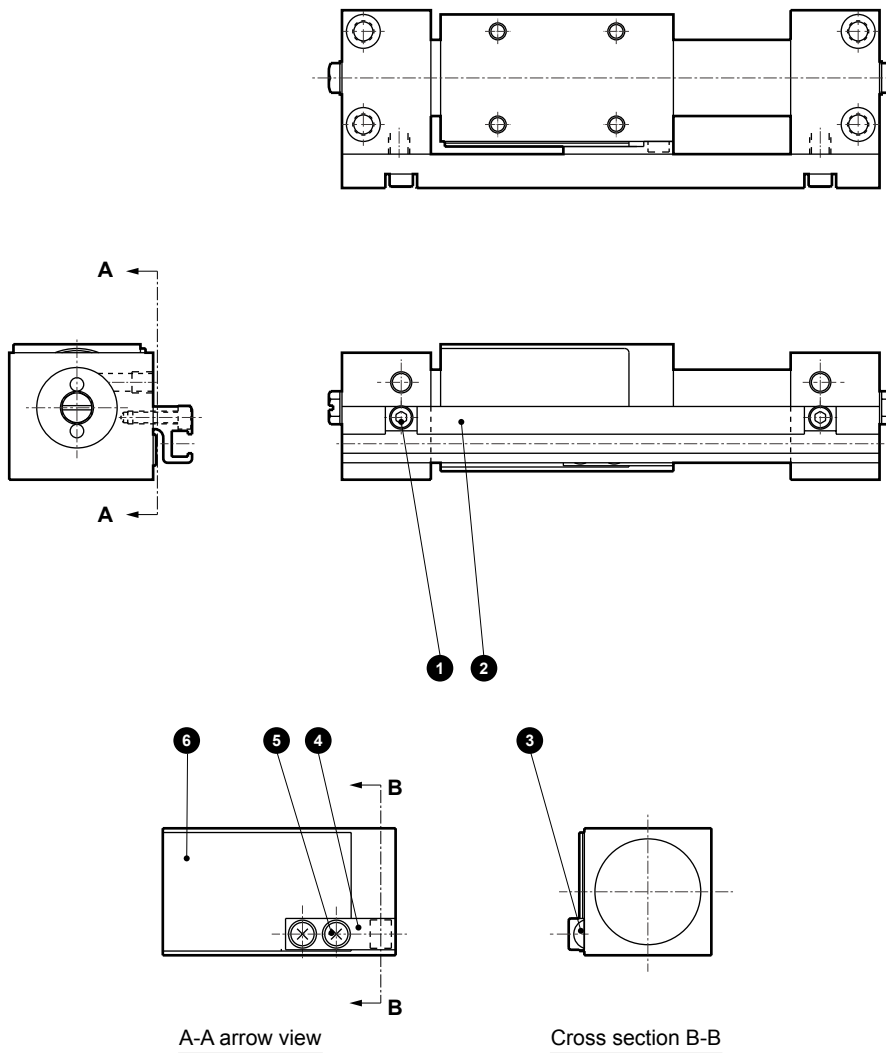

Cannot be disassembled

● Only available with MRL2-L-6

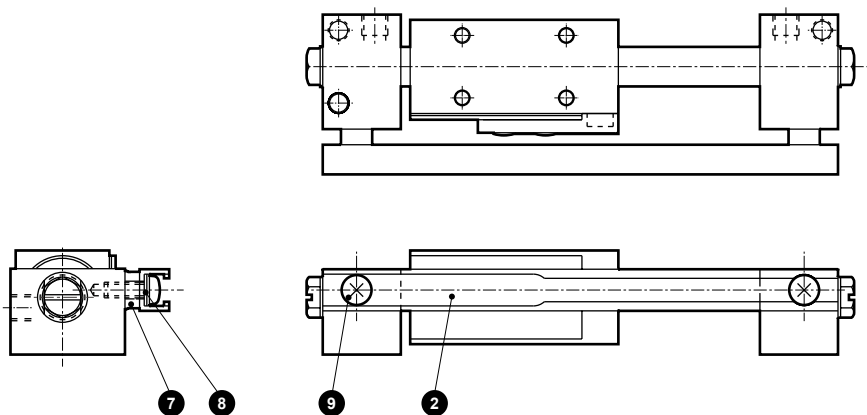

Cannot be disassembled

Parts list

No.	Part name	Material	Remarks	No.	Part name	Material	Remarks
1	Hexagon socket head cap screw	Stainless steel		6	Shield plate	Steel	Nickeling
2	Switch rail	Aluminum alloy	Alumite	7	Spacer	Copper alloy	Nickeling
3	Magnet	Special alloy		8	Plain washer	Stainless steel	
4	Magnet holder	Polyacetal resin		9	Cross-recessed pan head machine screw	Stainless steel	
5	Cross-recessed pan head machine screw	Stainless steel					

- SCP*3
- CMK2
- CMA2
- SCM
- SCG
- SCA2
- SCS2
- CKV2
- CAV2/COVP/N2
- SSD2
- SSG
- SSD
- CAT
- MDC2
- MVC
- SMG
- MSD/MSDG
- FC*
- STK
- SRL3
- SRG3
- SRM3
- SRT3
- MRL2**
- MRG2
- SM-25
- ShkAbs
- FJ
- FK
- Spd Contr
- Ending



Dimensions: MRL2 (basic)

● MRL2 (basic) without switch

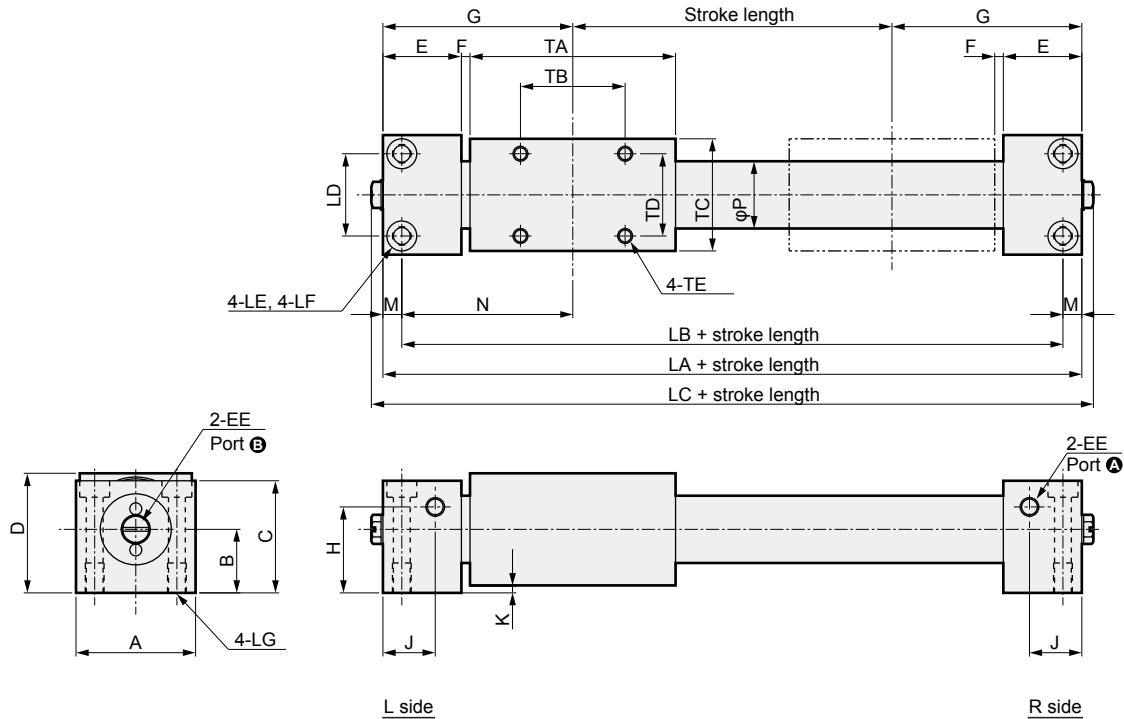

Note: It is possible to select **A** and **B** for air piping port.
 The unit will be shipped with the plug assembled onto port **B**.
 · φ6 to φ20: Plug (FPL-M5)
 · φ25, φ32: Hexagon socket head cap taper thread plug

Code	Dimensions					Mounting dimensions							
	LA	LC	A	C	D	LB	LD	LE	LF	LG	TB	TD	TE
φ6	74	80.2	20	16.5	20	68	14	φ3.5	-	M4 depth 6	20	12	M3 depth 4.5
φ10	80	86.2	26	24	26	72	18	φ3.5	φ6.5 spot face depth 3.3	M4 depth 8	20	18	M3 depth 4.5
φ16	102	108.2	32	30	32	92	22	φ4.5	φ8 spot face depth 4.4	M5 depth 8	28	22	M4 depth 6
φ20	128	134.2	38	36	38	116	26	φ5.5	φ9.5 spot face depth 5.4	M6 depth 12	44	26	M4 depth 6
φ25	130	132.2	52	45	48	118	40	φ5.5	φ9.5 spot face depth 5.4	M6 depth 12	40	30	M6 depth 6
φ32	138	140.2	60	53	56	124	46	φ6.9	φ11 spot face depth 6.5	M8 depth 12	40	40	M6 depth 9

Code	General dimensions												
	B	E	EE	F	G	H	J	K	M	N	P	TA	TC
φ6	11	15	M5 depth 4	2	37	9	9.5	2	3	34	7.6	40	18
φ10	14	18	M5 depth 4	2	40	5.5	10	2	4	36	12	40	24
φ16	17	21	M5 depth 4	2.5	51	23	14	2	5	46	18	55	30
φ20	20	24	M5 depth 4	3	64	28	15.5	2	6	58	23	74	36
φ25	25.5	27	Rc1/8	3	65	29	17	3	6	59	28	70	45
φ32	29.5	27	Rc1/8	3	69	37	17	3	7	62	35	78	53

Dimensions: MRL2 (basic)



● MRL2-L (basic) with switch

● For $\phi 6$

● For $\phi 10$

● For $\phi 16$ to $\phi 32$

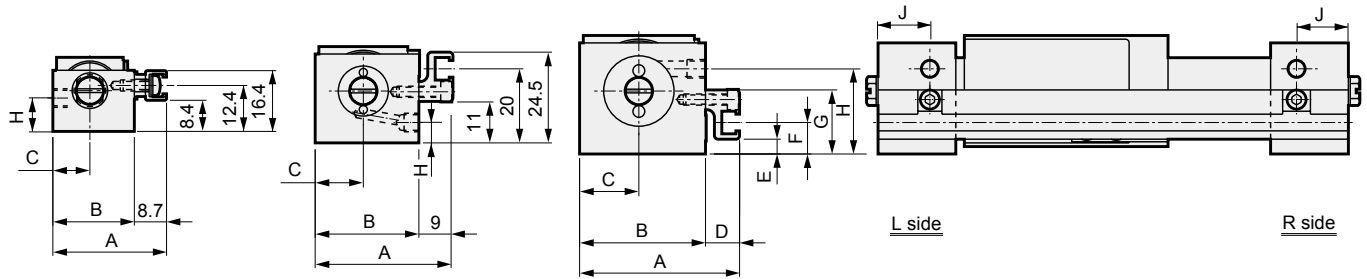

Code	A	B	C	D	E	F	G	H	J
Bore size (mm)									
$\phi 6$	30.7	22	10	-	-	-	-	9	9.5
$\phi 10$	37	28	13	-	-	-	-	5.5	10
$\phi 16$	43	34	16	9.0	4	8.5	17.3	23	14
$\phi 20$	49	40	19	9.0	9	13.5	22.3	28	15.5
$\phi 25$	60.7	52	26	8.7	2	7.5	21	29	17
$\phi 32$	68.7	60	30	8.7	10	15.5	29	37	17

SCP*3

CMK2

CMA2

SCM

SCG

SCA2

SCS2

CKV2

CAV2/
COVP/IN2

SSD2

SSG

SSD

CAT

MDC2

MVC

SMG

MSD/
MSDG

FC*

STK

SRL3

SRG3

SRM3

SRT3

MRL2

MRG2

SM-25

ShkAbs

FJ

FK

Spd
Contr

Ending

MRL2-G Series

Internal structure and parts list MRL2-G (simplified guide 1-piston)

● MRL2-G (simplified guide 1-piston)

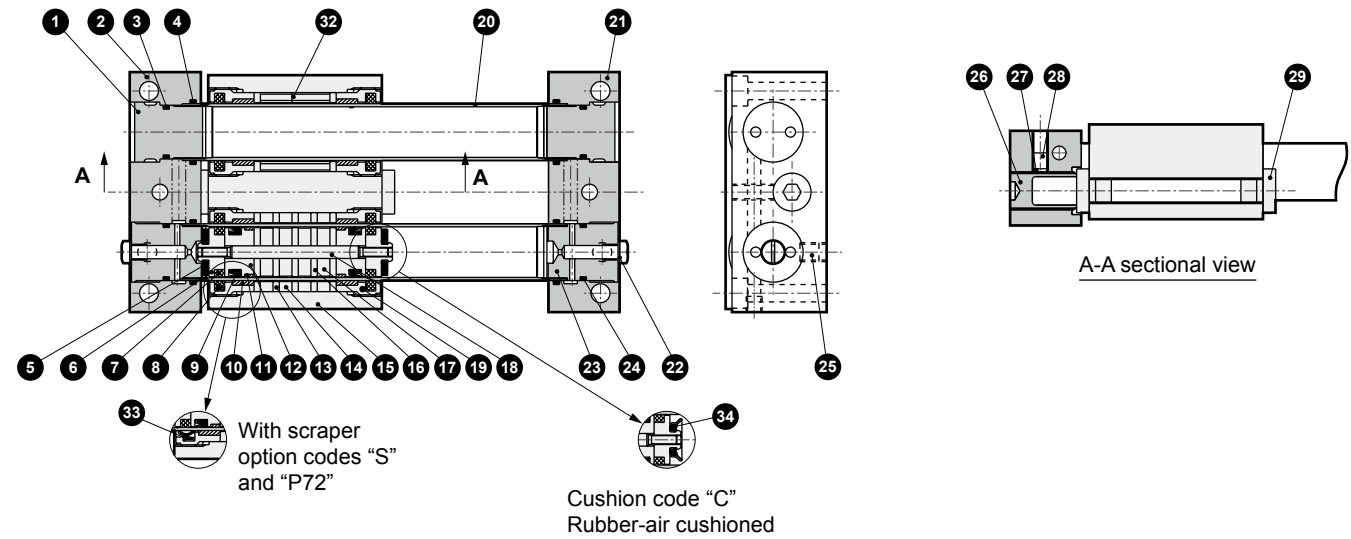

● MRL2-G*-C (with shock absorber)

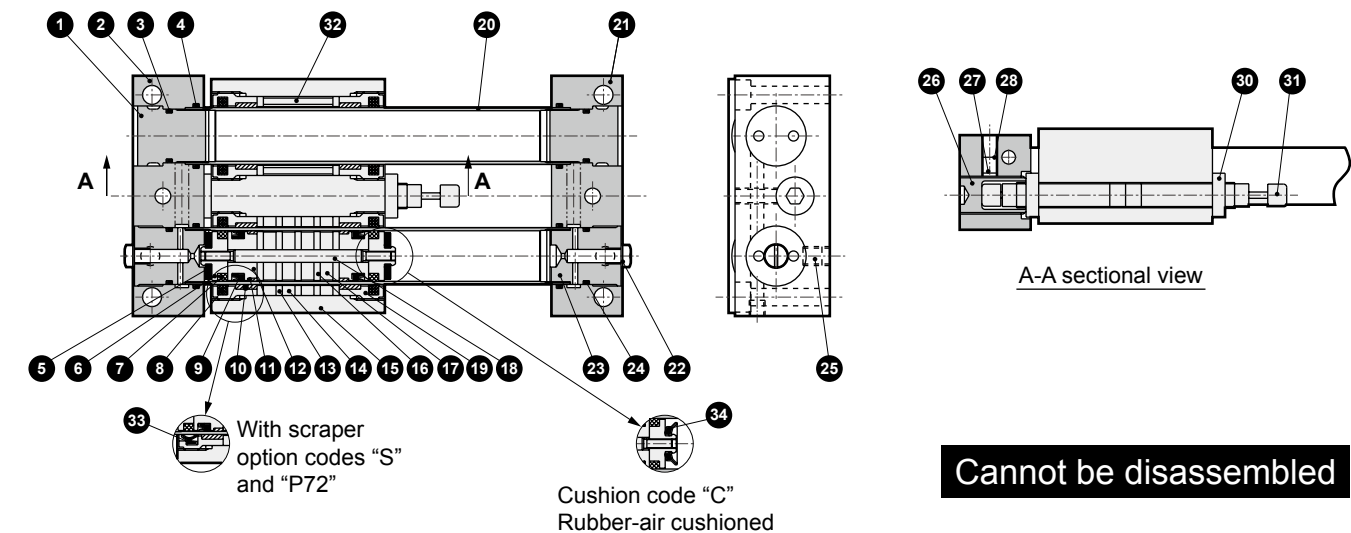

Cannot be disassembled

Parts list

No.	Part name	Material	Remarks	No.	Part name	Material	Remarks
1	End cap	Aluminum alloy	Chromate	18	Piston shaft	Stainless steel	
2	End plate (L)	Aluminum alloy	Alumite	19	Slider cover	Aluminum alloy	Chromate
3	O-ring	Nitrile rubber		20	Cylinder tube	Stainless steel	
4	O-ring	Nitrile rubber		21	End plate (R)	Aluminum alloy	Alumite
5	Cushion rubber	Urethane rubber		22	Plug	Copper alloy or steel	
6	Piston (2)	Aluminum alloy	Chromate	23	End cap	Aluminum alloy	Chromate
7	Lube keeping structure (for piston)	Special rubber		24	O-ring	Nitrile rubber	
8	Lube keeping structure (for slider)	Special rubber	None with P72	25	Hexagon socket set screw	Alloy steel	
9	Piston packing	Nitrile rubber		26	Stopper	Alloy steel	Nickeling
10	Slider wear ring	Polyacetal resin		27	Set shoe	Aluminum alloy	
11	Piston wear ring	Polyacetal resin		28	Hexagon socket set screw	Stainless steel	
12	Piston (1)	Aluminum alloy	Chromate	29	Stopper bolt	Steel	Nickeling
13	Slider yoke	Steel	Zinc chromate	30	Hexagon nut	Steel	
14	Magnet	Special alloy		31	Shock absorber		
15	Slider	Aluminum alloy	Alumite	32	Spacer	Stainless steel	
16	Piston yoke	Steel	Zinc chromate	33	Scraper	Urethane rubber	
17	Magnet	Special alloy		34	Rubber-air cushion	Special rubber	

Note: The magnetic strength of the magnet is powerful. Do not disassemble.

Internal structure and parts list MRL2-G (simplified guide 1-piston)

● MRL2-GL (with switch)

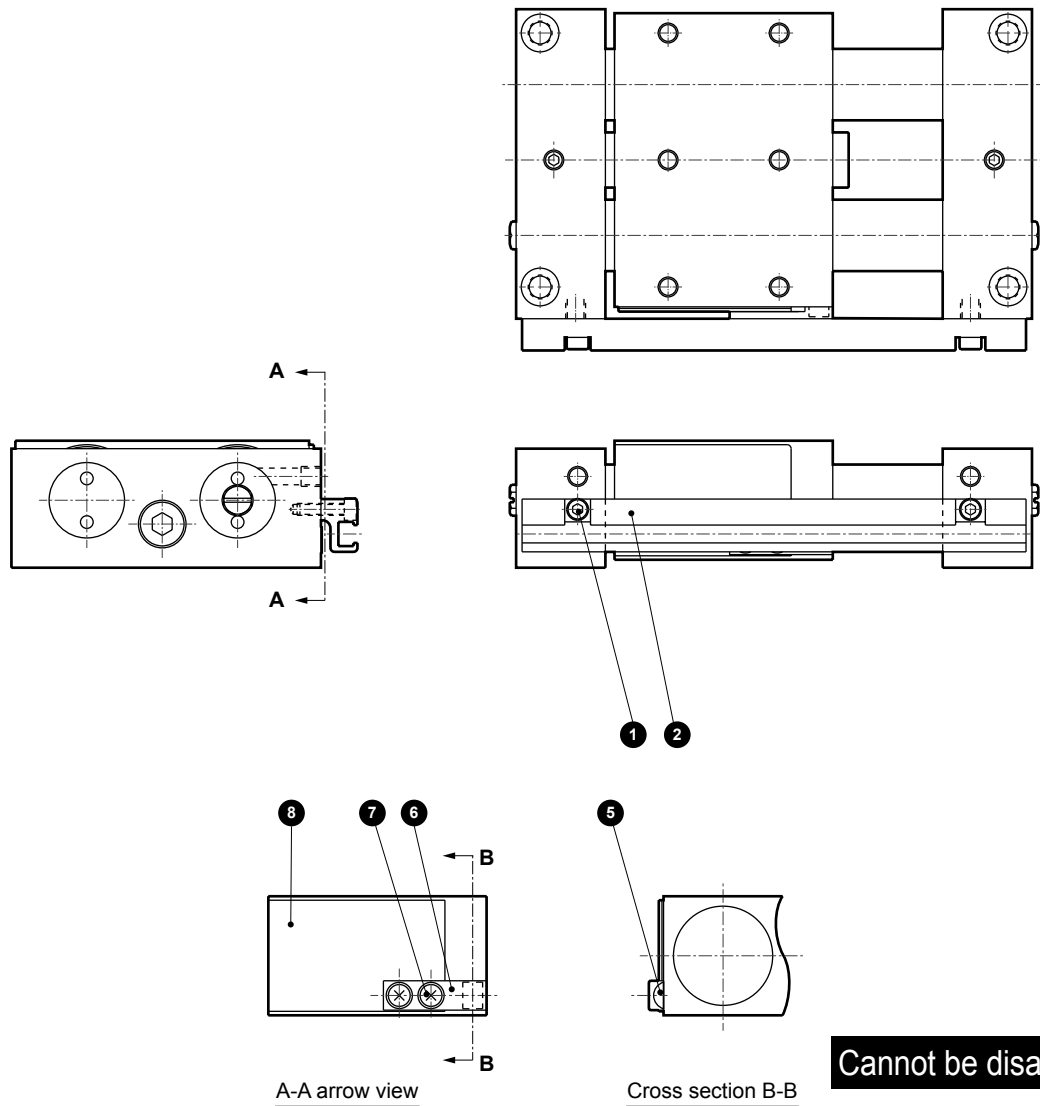

● MRL2-GL-*R (common piping with switch)

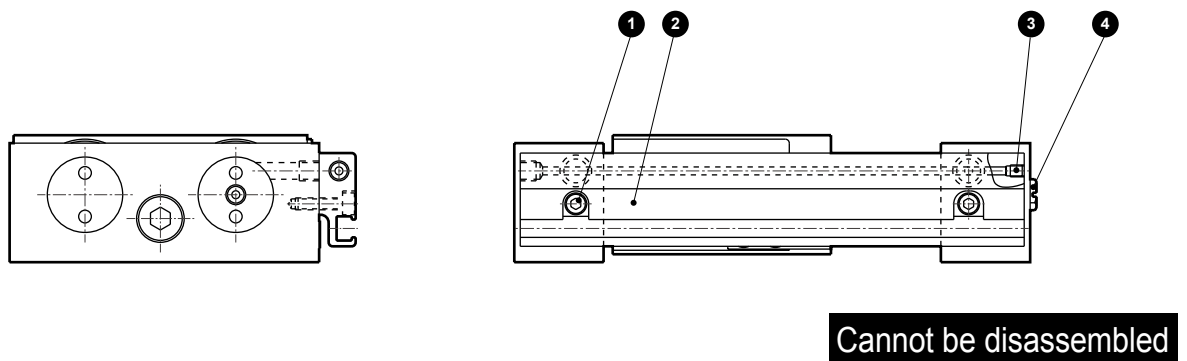

Parts list

No.	Part name	Material	Remarks	No.	Part name	Material	Remarks
1	Hexagon socket head cap screw	Stainless steel		5	Magnet	Special alloy	
2	Switch rail	Aluminum alloy	Alumite	6	Magnet holder	Polyacetal resin	
3	Hexagon socket set screw	Stainless steel		7	Cross-recessed pan head machine screw	Stainless steel	
4	Plug	Copper alloy or steel		8	Shield plate	Steel	Nickeling

SCP*3

CMK2

CMA2

SCM

SCG

SCA2

SCS2

CKV2

CAV2/
COVP/N2

SSD2

SSG

SSD

CAT

MDC2

MVC

SMG

MSD/
MSDG

FC*

STK

SRL3

SRG3

SRM3

SRT3

MRL2

MRG2

SM-25

ShkAbs

FJ

FK

Spd
Contr

Ending

MRL2-W Series

Internal structure and parts list MRL2-W (simplified guide 2-piston)

● MRL2-W (simplified guide 2-piston)

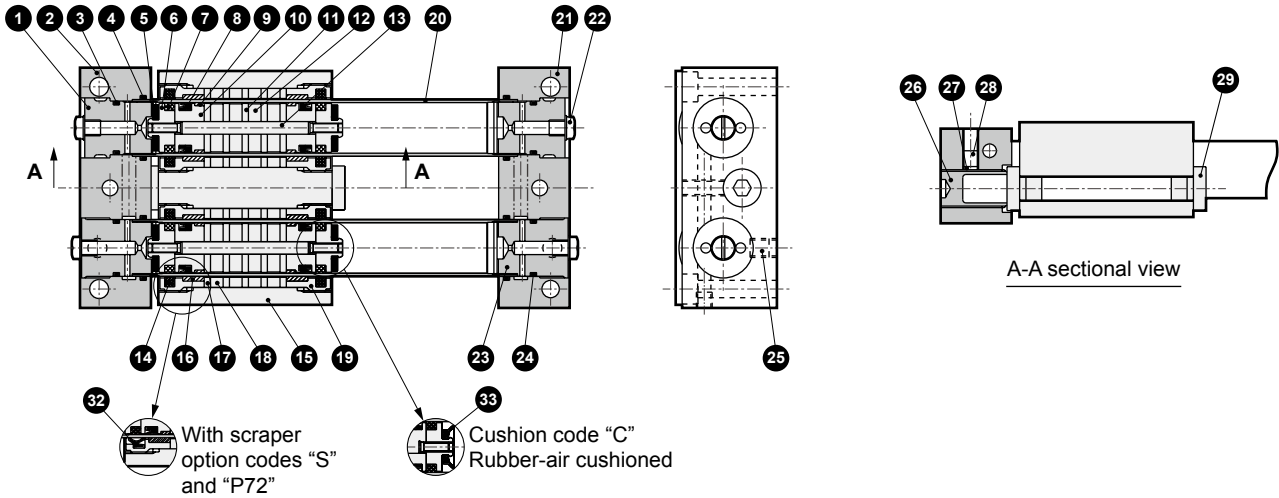

● MRL2-W*-C (with shock absorber)

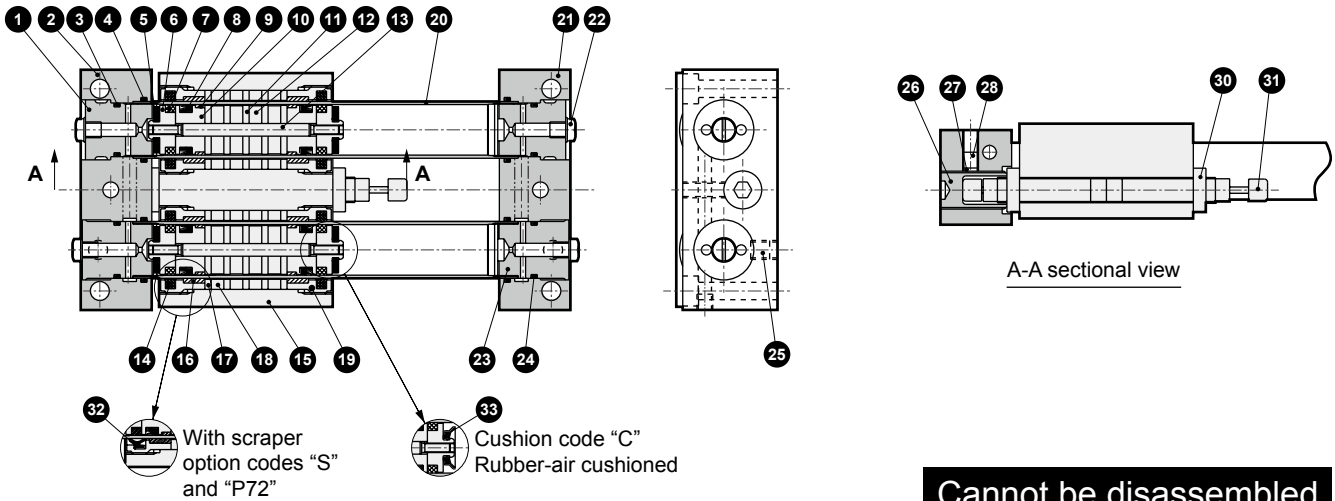

Cannot be disassembled

Parts list

No.	Part name	Material	Remarks	No.	Part name	Material	Remarks
1	End cap	Aluminum alloy	Chromate	17	Slider yoke	Steel	Zinc chromate
2	End plate (L)	Aluminum alloy	Alumite	18	Magnet	Special alloy	
3	O-ring	Nitrile rubber		19	Slider cover	Aluminum alloy	Chromate
4	O-ring	Nitrile rubber		20	Cylinder tube	Stainless steel	
5	Cushion rubber	Urethane rubber		21	End plate (R)	Aluminum alloy	Alumite
6	Piston (2)	Aluminum alloy	Chromate	22	Plug	Copper alloy or steel	
7	Lube keeping structure (for piston)	Special rubber		23	End cap	Aluminum alloy	Chromate
8	Piston packing	Nitrile rubber		24	O-ring	Nitrile rubber	
9	Piston wear ring	Polyacetal resin		25	Hexagon socket set screw	Alloy steel	
10	Piston (1)	Aluminum alloy	Chromate	26	Stopper	Alloy steel	Nickeling
11	Piston yoke	Steel	Zinc chromate	27	Set shoe	Aluminum alloy	
12	Magnet	Special alloy		28	Hexagon socket set screw	Stainless steel	
13	Piston shaft	Stainless steel		29	Stopper bolt	Steel	Nickeling
14	Lube keeping structure (for slider)	Special rubber		30	Hexagon nut	Steel	
15	Slider	Aluminum alloy	Alumite	31	Shock absorber		
16	Slider wear ring	Polyacetal resin		32	Scraper	Urethane rubber	
				33	Rubber-air cushion	Special rubber	

Note: The magnetic strength of the magnet is powerful. Do not disassemble.

Internal structure and parts list MRL2-W (simplified guide 2-piston)

● MRL2-WL (with switch)

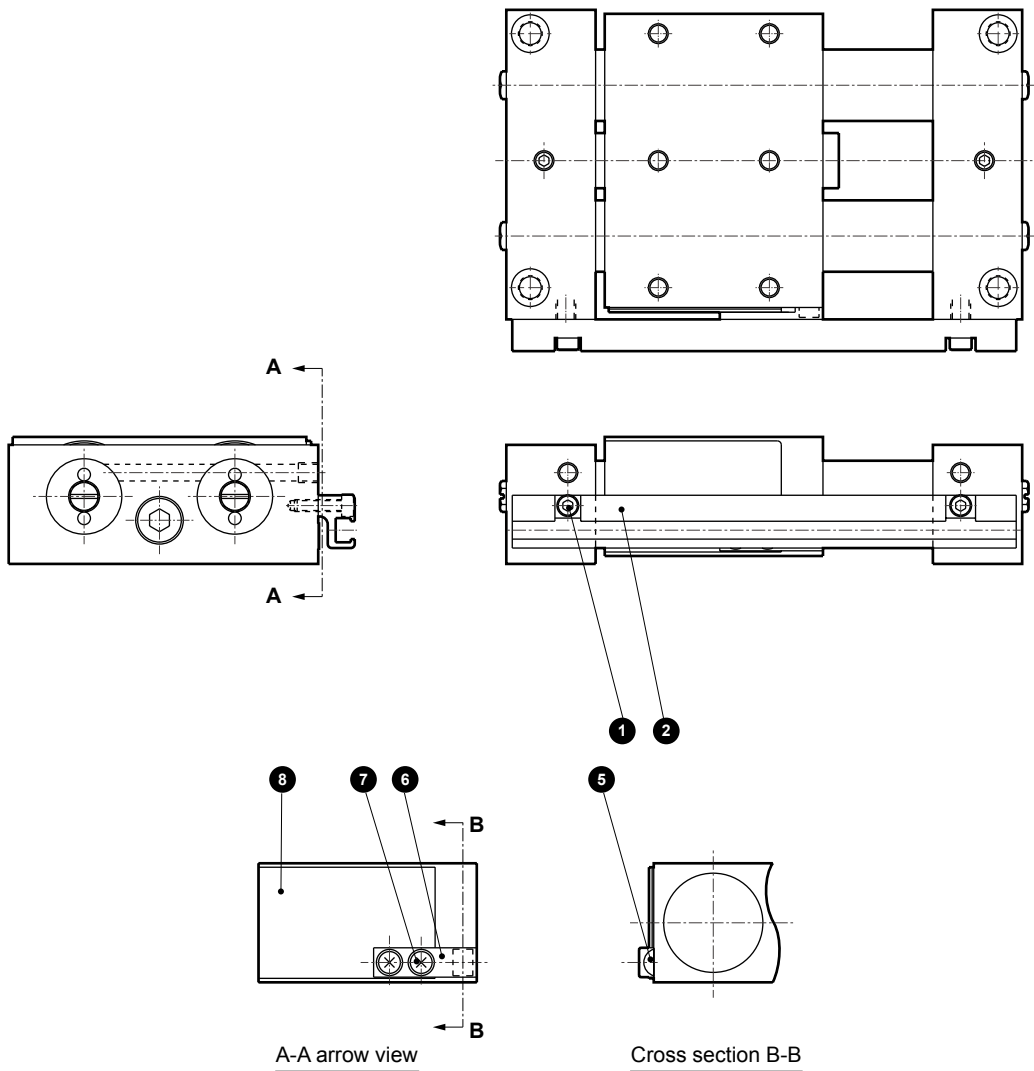

Cannot be disassembled

● MRL2-WL-* -R (common piping with switch)

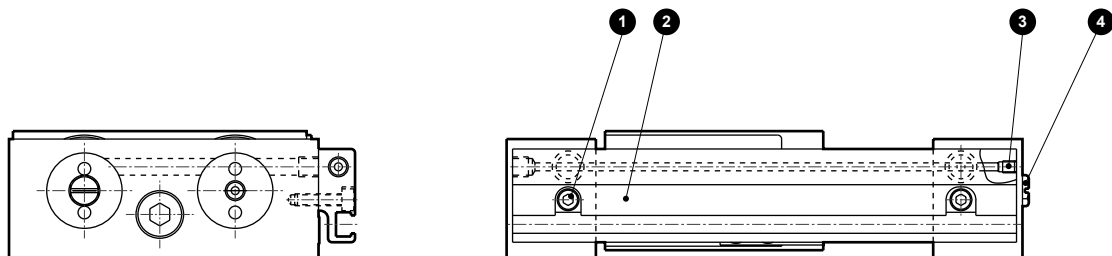

Cannot be disassembled

Parts list

No.	Part name	Material	Remarks	No.	Part name	Material	Remarks
1	Hexagon socket head cap screw	Stainless steel		5	Magnet	Special alloy	
2	Switch rail	Aluminum alloy	Alumite	6	Magnet holder	Polyacetal resin	
3	Hexagon socket set screw	Stainless steel		7	Cross-recessed pan head machine screw	Stainless steel	
4	Plug	Copper alloy or steel		8	Shield plate	Steel	Nickeling

- SCP*3
- CMK2
- CMA2
- SCM
- SCG
- SCA2
- SCS2
- CKV2
- CAV2/
COVP/IN2
- SSD2
- SSG
- SSD
- CAT
- MDC2
- MVC
- SMG
- MSD/
MSDG
- FC*
- STK
- SRL3
- SRG3
- SRM3
- SRT3
- MRL2**
- MRG2
- SM-25
- ShkAbs
- FJ
- FK
- Spd
Contr
- Ending



Dimensions: MRL2-G (simplified guide 1-piston)/MRL2-W (simplified guide 2-piston)

- MRL2-G (simplified guide 1-piston) without switch
- MRL2-W (simplified guide 2-piston) without switch

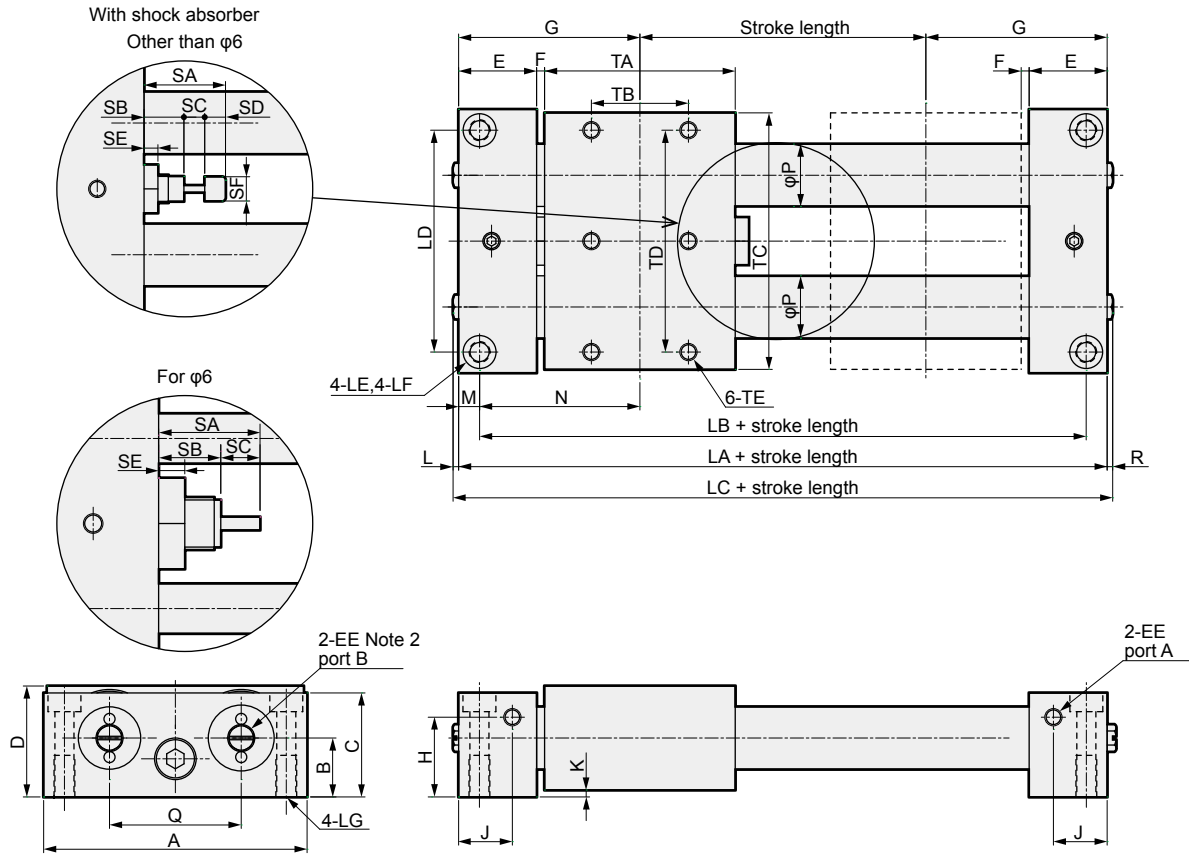

*1: It is possible to select **A** and **B** for air piping port.
 The unit will be shipped with the plug assembled onto port **B**.
 · φ6 to φ20: Plug (FPL-M5)
 · φ25, φ32: Hexagon socket head cap taper thread plug

*2: MRL2-W is "4-EE".

Code	Dimensions								Mounting dimensions							
	LA	LC	L	R	A	C	D	LB	LD	LE	LF	LG	TB	TD	TE	
φ6	74	80.2	3.1	3.1	46	20	24	68	40	φ3.5	-	M4 depth 6	20	38	M3 depth 4.5	
φ10	83	87.2	1.6	2.6	64	24	26	74	54	φ4.5	φ8 spot face depth 4.4	M5 depth 10	20	55	M4 depth 6	
φ16	105	109.2	1.6	2.6	76	30	32	93	64	φ5.5	φ9.5 spot face depth 5.4	M6 depth 12	28	64	M5 depth 8	
φ20	131	135.2	1.6	2.6	90	36	38	119	77	φ6.9	φ11 spot face depth 6.5	M8 depth 12	44	78	M5 depth 8	
φ25	136	138	0	2	108	45	48	122	90	φ6.9	φ11 spot face depth 6.5	M8 depth 12	40	90	M6 depth 9	
φ32	144	146	0	2	126	53	56	130	108	φ6.9	φ11 spot face depth 6.5	M8 depth 12	40	104	M6 depth 9	

Code	General dimensions																			
	B	E	EE	F	G	H	J	K	M	N	P	Q	SA	SB	SC	SD	SE	SF	TA	TC
φ6	13	15	M5 depth 4	2	37	9	9.5	2	3	34	7.6	26	15.5	9.5	6	-	4	-	40	44
φ10	14	19.5	M5 depth 4	2	41.5	5.5	11.5	2	4.5	37	12	34	20.5	9.5	5	6	4	6	40	62
φ16	17	22.5	M5 depth 4	2.5	52.5	23	15.5	2	6	46.5	18	38	23.5	11.5	6	6	4	7	55	74
φ20	20	25.5	M5 depth 4	3	65.5	28	17	2	6	59.5	23	46	25.5	10.5	8	7	4	8	74	88
φ25	25.5	30	Rc1/8	3	68	29	20	3	7	61	28	50	30	12.5	10	7.5	5	10	70	101
φ32	29.5	30	Rc1/8	3	72	37	20	3	7	65	35	60	30	12.5	10	7.5	5	10	78	119

Dimensions: MRL2-G (simplified guide 1-piston)/MRL2-W (simplified guide 2-piston)

- MRL2-GL (simplified guide 1-piston) with switch
- MRL2-WL (simplified guide 2-piston) with switch



- For $\phi 6$

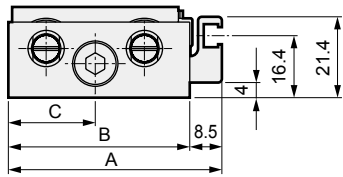

- For $\phi 10$

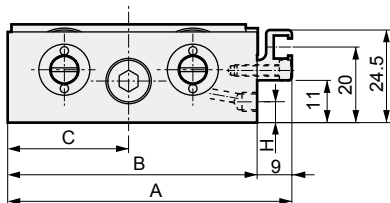

- For $\phi 16$ to $\phi 32$

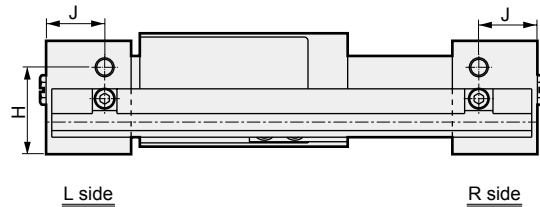
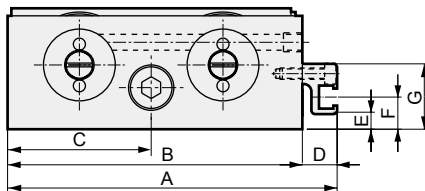

Code	A	B	C	D	E	F	G	H	J
Bore size (mm)									
$\phi 6$	56.5	48	23	-	-	-	-	9	9.5
$\phi 10$	75	66	32	-	-	-	-	5.5	11.5
$\phi 16$	87	78	38	9	4	8.5	17.3	23	15.5
$\phi 20$	101	92	45	9	9	13.5	22.3	28	17
$\phi 25$	116.7	108	54	8.7	2	7.5	21	29	20
$\phi 32$	134.7	126	63	8.7	10	15.5	29	37	20

- MRL2-GL-*R (simplified guide 1-piston) common piping with switch
- MRL2-WL-*R (simplified guide 2-piston) common piping with switch

- For $\phi 10$

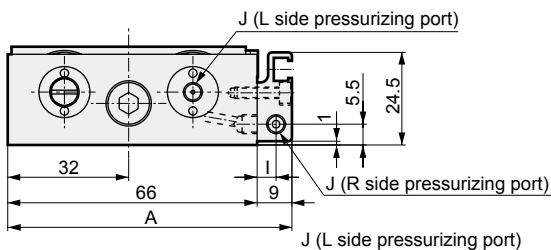

- For $\phi 16$ to $\phi 32$

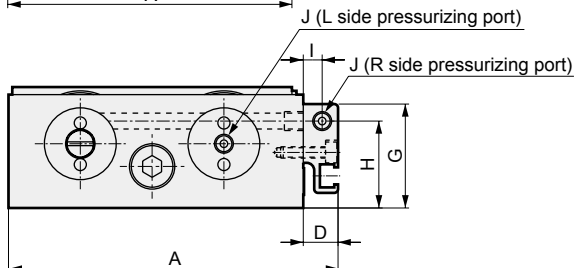

Code	A	D	G	H	I	J
Bore size (mm)						
$\phi 10$	75	-	-	-	5	M5 depth 4
$\phi 16$	87	9	27.5	23	5	M5 depth 4
$\phi 20$	101	9	32.5	28	5	M5 depth 4
$\phi 25$	122	14	45	29	7.5	Rc1/8
$\phi 32$	140	14	53	37	7.5	Rc1/8

- SCP*3
- CMK2
- CMA2
- SCM
- SCG
- SCA2
- SCS2
- CKV2
- CAV2/
COVP/N2
- SSD2
- SSG
- SSD
- CAT
- MDC2
- MVC
- SMG
- MSD/
MSDG
- FC*
- STK
- SRL3
- SRG3
- SRM3
- SRT3
- MRL2**
- MRG2
- SM-25
- ShkAbs
- FJ
- FK
- Spd
Contr
- Ending

MRL2 Series

Switch mounting position dimensions

● MRL2-L-* (switch: T2^{H/V}, T3^{H/V}, T2W^{H/V}, T3W^{H/V})
GL
WL

● For $\phi 6$ ● For $\phi 10$ ● For $\phi 16$ to $\phi 32$

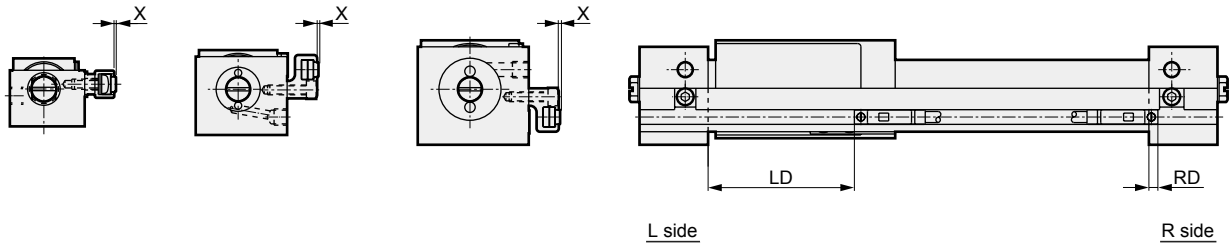

Code	T2 ^{H/V} , T3 ^{H/V}			T2W ^{H/V} , T3W ^{H/V}		
	Bore size (mm)	RD	LD	X	RD	HD
$\phi 6$	3.5	27	0.5	1.5	29	0.5
$\phi 10$	2.5	27	0.5	0.5	29	0.5
$\phi 16$	2.5	44	0.5	0.5	46	0.5
$\phi 20$	1	63.5	0.5	-1	65.5	0.5
$\phi 25$	2	58	0.5	0	60	0.5
$\phi 32$	1.5	67.5	0.5	-0.5	69	0.5

● MRL2-L-* (switch: T1^{H/V}, T2Y^{H/V}, T3Y^{H/V})
GL
WL

● For $\phi 6$ ● For $\phi 10$ ● For $\phi 16$ to $\phi 32$

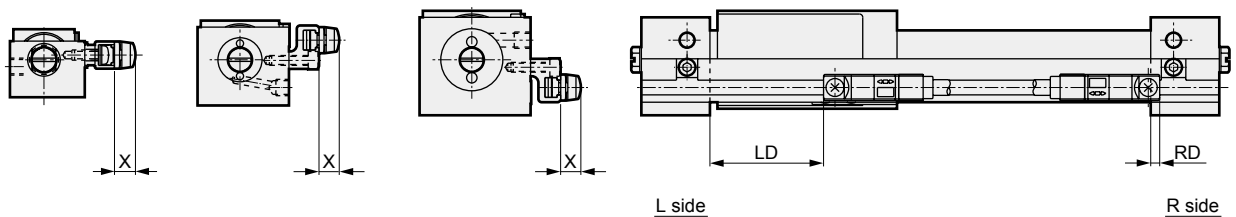

Code	RD	LD	X
$\phi 6$	4.5	26	6(11.5)
$\phi 10$	3.5	26	6(11.5)
$\phi 16$	3.5	43	6(11.5)
$\phi 20$	2	62.5	6(11.5)
$\phi 25$	3	57	6(11.5)
$\phi 32$	2.5	66	6(11.5)

*1: Values in () are for T1^{H/V}.