

LCW
LCR
LCG
LCX
LCM
STM
STG
STS/STL
STR2
UCA2
ULK*
JSK/M2
JSG
JSC3/JSC4
USSD
UFCD
USC
JSB3
LMB
LML
HCM
HCA
LBC
CAC4
UCAC2
CAC-N
UCAC-N
RCC2
RCS
PCC
SHC
MCP
GLC
MFC
BBS
RRC
GRC
RV3*
NHS
HR
LN
Hand
Chuk
MecHnd/Chuk
ShkAbs
FJ
FK
SpdContr
Ending

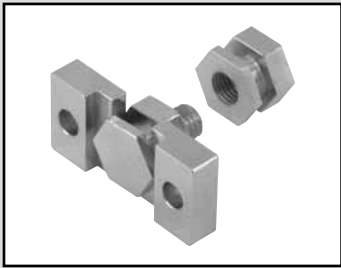

Simplified floating fitting

FK Series

● Cylinder diameter: $\phi 6$ to $\phi 100$



Specifications

Model No.		Allowable load *1 (N)	Allowable eccentricity (mm)	Backlash amount in thrust direction (mm)
Male thread	Female thread			
FK-M3-N	FK-M3	63	±0.3	0.1 to 0.3
FK-M4-N	FK-M4	110		
FK-M5-N	FK-M5	179		
FK-M6-N	FK-M6	253		
FK-M8-N	FK-M8 × 1.0	462		
—	FK-M8 × 1.25	462		
FK-M10-N	FK-M10	734		
—	FK-M12	1069		
—	FK-M14	1466		
FK-M16-N	FK-M16	2003		
—	FK-M18	2448		
FK-M20-N	—	3130		
—	FK-M22	3896		
—	FK-M26	6219		
—	—	—		

*1: Allowable load indicates static load.

How to order

● Simplified floating fitting

FK - M3-N

Model No.

Ⓐ Thread size

Code	Content		
Ⓐ Thread size			
M3-N	M3 × 0.5	Male thread	
M4-N	M4 × 0.7		
M5-N	M5 × 0.8		
M6-N	M6 × 1.0		
M8-N	M8 × 1.25		
M10-N	M10 × 1.5		
M16-N	M16 × 2.0		
M20-N	M20 × 2.5		
M3	M3 × 0.5		Female thread
M4	M4 × 0.7		
M5	M5 × 0.8		
M6	M6 × 1.0		
M8 × 1.0	M8 × 1.0		
M8 × 1.25	M8 × 1.25		
M10	M10 × 1.25		
M12	M12 × 1.5		
M14	M14 × 1.5		
M16	M16 × 1.5		
M18	M18 × 1.5		
M22	M22 × 1.5		
M26	M26 × 1.5		

Specifications for rechargeable battery (Catalog No. CC-1226A)

FK - [Thread size] - P40

● Design compatible with rechargeable battery manufacturing process

* Contact CKD for details.

Dimensions



Material : Steel
Surface treatment : Nickeling

● Bracket (1)

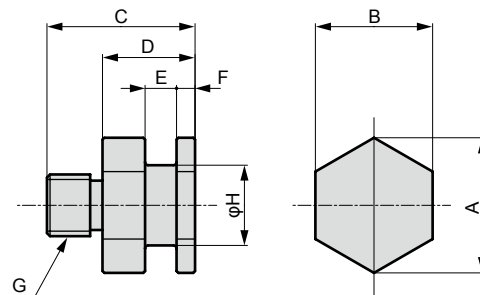

● Bracket (2)

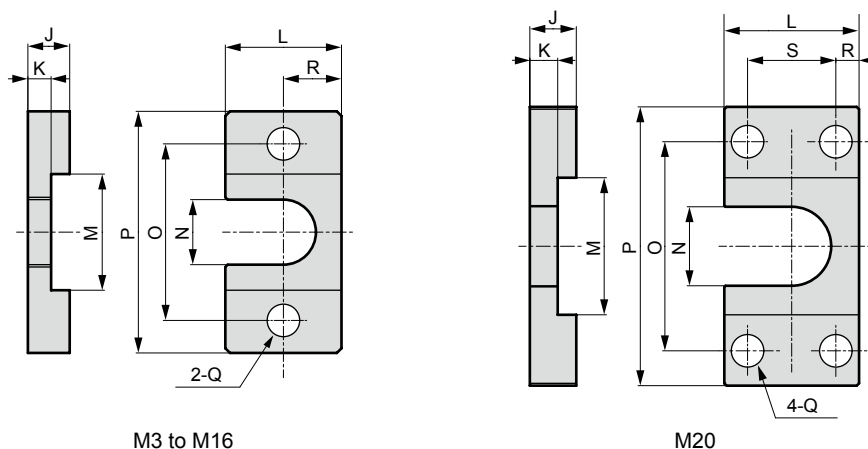

M3 to M16

M20

Bracket (1)

Model No.	Cylinder	A	B	C	D	E	F	G	H	Weight g
FK-M3-N	SSD/SSD2-12	11.6	10	15	10	3.1 ^{+0.1} ₀	2	M3×0.5	6	5.3
FK-M4-N	SSD/SSD2-16	11.6	10	15.5	10	3.1 ^{+0.1} ₀	2	M4×0.7	6	5.5
FK-M5-N	SSD/SSD2-20, FCD-25	13.9	12	16.5	10	3.1 ^{+0.1} ₀	2	M5×0.8	8	8.3
FK-M6-N	SSD/SSD2-25, FCD-32	13.9	12	19	10	3.1 ^{+0.1} ₀	2	M6×1.0	8	8.9
FK-M8-N	SSD/SSD2-32, 40, FCD-40, 50	21.9	19	23	15	5.1 ^{+0.1} ₀	3	M8×1.25	13	30.8
FK-M10-N	SSD/SSD2-50, 63, FCD-63	21.9	19	24	15	5.1 ^{+0.1} ₀	3	M10×1.5	13	32.7
FK-M16-N	SSD/SSD2-80	37	32	31	20	7.1 ^{+0.1} ₀	4	M16×2.0	23	122.5
FK-M20-N	SSD/SSD2-100	53.1	46	43	28	12.1 ^{+0.1} ₀	7	M20×2.5	32	333

Bracket (2)

Model No.	Cylinder	J	K	L	M	N	O	P	Q	R	S	Weight g
FK-M3-N	SSD/SSD2-12	6	3 ⁰ _{-0.1}	16	14	7	24	34	4.5	8	—	16
FK-M4-N	SSD/SSD2-16	6	3 ⁰ _{-0.1}	16	14	7	24	34	4.5	8	—	16
FK-M5-N	SSD/SSD2-20, FCD-25	6	3 ⁰ _{-0.1}	19	16	9	26	36	4.5	9.5	—	19.6
FK-M6-N	SSD/SSD2-25, FCD-32	6	3 ⁰ _{-0.1}	19	16	9	26	36	4.5	9.5	—	19.6
FK-M8-N	SSD/SSD2-32, 40, FCD-40, 50	9	5 ⁰ _{-0.1}	25	25	14	38	52	7	12.5	—	54.5
FK-M10-N	SSD/SSD2-50, 63, FCD-63	9	5 ⁰ _{-0.1}	25	25	14	38	52	7	12.5	—	54.5
FK-M16-N	SSD/SSD2-80	12	7 ⁰ _{-0.1}	44	42	25	62	85	11	22	—	216
FK-M20-N	SSD/SSD2-100	22	12 ⁰ _{-0.1}	65	59	34	90	120	14	13.5	38	788

LCW
LCR
LCG
LCX
LCM
STM
STG
STS/STL
STR2
UCA2
ULK*
JSK/M2
JSG
JSC3/JSC4
USSD
UFCD
USC
JSB3
LMB
LML
HCM
HCA
LBC
CAC4
UCAC2
CAC-N
UCAC-N
RCC2
RCS
PCC
SHC
MCP
GLC
MFC
BBS
RRC
GRC
RV3*
NHS
HR
LN
Hand
Chuk
MecHnd/Chuk
ShkAbs
FJ
FK
SpdContr

Ending

Dimensions



Material : Steel
Surface treatment : Nickeling

● Bracket (1)

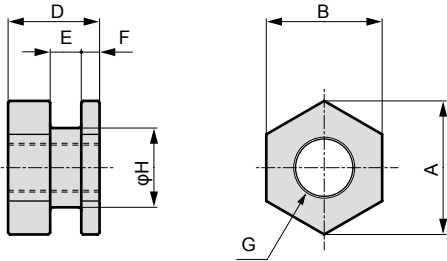

● Bracket (2)

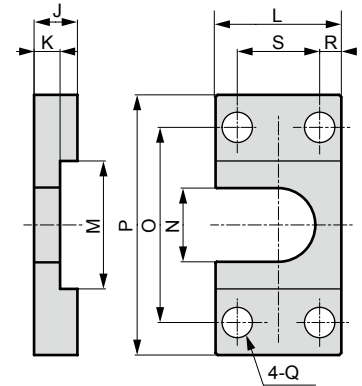
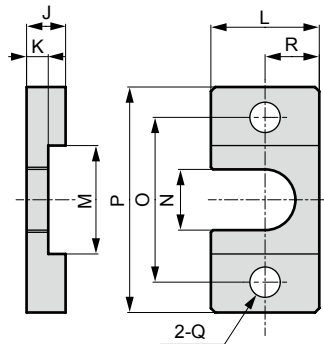

M3 to M18

M22 to M26

Bracket (1)

Model No.	Cylinder	A	B	D	E	F	G	H	Weight g
FK-M3	SCPD3-6, CAT-6, SMG-6	11.6	10	10	3.1 ^{+0.1} ₀	2	M3×0.5	6	4.6
FK-M4	SCPD3-10, CAT-10, SMG-10	11.6	10	10	3.1 ^{+0.1} ₀	2	M4×0.7	6	4.1
FK-M5	SCPD3-16, CAT-15, SMG-16 SSD-12-N	13.9	12	10	3.1 ^{+0.1} ₀	2	M5×0.8	8	6.2
FK-M6	SMG-20, SSD/SSD2-16-N	13.9	12	10	3.1 ^{+0.1} ₀	2	M6×1.0	8	5.7
FK-M8×1.0	CMK2-20, CMA2-20, JSK2-20, JSM2-20	21.9	19	15	5.1 ^{+0.1} ₀	3	M8×1.0	13	23
FK-M8×1.25	SMG-25, SSD/SSD2-20-N, SCM-20	21.9	19	15	5.1 ^{+0.1} ₀	3	M8×1.25	13	23.4
FK-M10	CMK2-25/32, CMA2-30, SMG-32, SSD/SSD2-25-N, SCG-32, SCM-25/32, FCD-25-N, JSK2-25/32, JSM2-30	21.9	19	15	5.1 ^{+0.1} ₀	3	M10×1.25	13	20.2
FK-M12	CMK2-40, CMA2-40, JSK2-40, JSM2-40	27.7	24	15	5.1 ^{+0.1} ₀	3	M12×1.5	18	35.7
FK-M14	SCA2-40, SSD/SSD2-32/40-N/SCG-40, SCM-40, FCD-32/40-N, JSC3-40	27.7	24	15	5.1 ^{+0.1} ₀	3	M14×1.5	18	31.2
FK-M16	CAV2-50	37	32	20	7.1 ^{+0.1} ₀	4	M16×1.5	23	81.3
FK-M18	SCA2-50/63, SSD/SSD2-50/63-N, SCM-50/63, SCG-50/63, FCD-50/63-N, JSC3-50/63	37	32	20	7.1 ^{+0.1} ₀	4	M18×1.5	23	73.1
FK-M22	SCA2-80, SSD/SSD2-80-N, JSC3-80, SCG-80, SCM-80, CAV2-75/100	53.1	46	28	12.1 ^{+0.1} ₀	7	M22×1.5	32	226
FK-M26	SCA2-100, SSD/SSD2-100-N, SCM-100, JSC3-100, SCG-100	53.1	46	28	12.1 ^{+0.1} ₀	7	M26×1.5	32	193

Bracket (2)

Model No.	Cylinder	J	K	L	M	N	O	P	Q	R	S	Weight g
FK-M3	SCPD3-6, CAT-6, SMG-6	6	3 ⁰ _{-0.1}	16	14	7	24	34	4.5	8	—	16
FK-M4	SCPD3-10, CAT-10, SMG-10	6	3 ⁰ _{-0.1}	16	14	7	24	34	4.5	8	—	16
FK-M5	SCPD3-16, CAT-15, SMG-16 SSD/SSD2-12-N	6	3 ⁰ _{-0.1}	19	16	9	26	36	4.5	9.5	—	19.6
FK-M6	SMG-20, SSD/SSD2-16-N	6	3 ⁰ _{-0.1}	19	16	9	26	36	4.5	9.5	—	19.6
FK-M8×1.0	CMK2-20, CMA2-20, JSK2-20, JSM2-20	9	5 ⁰ _{-0.1}	25	25	14	38	52	7	12.5	—	54.5
FK-M8×1.25	SMG-25, SSD/SSD2-20-N, SCM-20	9	5 ⁰ _{-0.1}	25	25	14	38	52	7	12.5	—	54.5
FK-M10	CMK2-25/32, CMA2-30, SMG-32, SSD/SSD2-25-N, SCG-32, SCM-25/32, FCD-25-N, JSK2-25/32, JSM2-30	9	5 ⁰ _{-0.1}	25	25	14	38	52	7	12.5	—	54.5
FK-M12	CMK2-40, CMA2-40	9	5 ⁰ _{-0.1}	32	32	19	50	70	9	16	—	94.5
FK-M14	SCA2-40, SSD/SSD2-32/40-N/SCG-40, SCM-40, FCD-32/40-N, JSC3-40	9	5 ⁰ _{-0.1}	32	32	19	50	70	9	16	—	94.5
FK-M16	CAV2-50	12	7 ⁰ _{-0.1}	44	42	25	62	85	11	22	—	216
FK-M18	SCA2-50/63, SSD/SSD2-50/63-N, SCM-50/63, SCG-50/63, FCD-50/63-N, JSC3-50/63	12	7 ⁰ _{-0.1}	44	42	25	62	85	11	22	—	216
FK-M22	SCA2-80, SSD/SSD2-80-N, JSC3-80, SCG-80, SCM-80, CAV2-75/100	22	12 ⁰ _{-0.1}	65	59	34	90	120	14	13.5	38	788
FK-M26	SCA2-100, SSD/SSD2-100-N, SCM-100, JSC3-100, SCG-100	22	12 ⁰ _{-0.1}	65	59	34	90	120	14	13.5	38	788