



Thin parallel hand (bush/bearing guide) Double acting

HLA/HLB Series

- Operational stroke length: HLA 15, 20, 25 mm
HLB 13, 18, 23mm

Double acting



Specifications

Descriptions		HLA			HLB		
Size		12CS	15CS	20CS	12CS	15CS	20CS
Bore size	mm	φ12	φ15	φ20	φ12	φ15	φ20
Actuation		Double acting					
Working fluid		Compressed air					
Max. working pressure	MPa	0.7 (≈100 psi, 7 bar)					
Min. working pressure	MPa	0.3 (≈44 psi, 3 bar)			0.1 (≈15 psi, 1 bar)		
Ambient temperature	°C	5 (41°F) to 60 (140°F)					
Port size		M5					
Operating stroke length	mm	15	20	25	13	18	23
Volumetric capacity (reciprocating)	cm ³	1.69	3.53	7.85	1.47	3.18	7.22
Repeatability	mm	±0.03			±0.01		
Weight	kg	0.152	0.276	0.504	0.214	0.402	0.678
Lubrication		Not required (use turbine oil class 1 ISO VG32 if necessary for lubrication)					

Switch specifications and variations

Descriptions	Proximity 2-wire	Proximity 3-wire
	K2H, K2V	K3H, K3V
Applications	Dedicated for programmable controller	For programmable controller, relay
Output method	-	NPN output
Power supply voltage	-	10 to 28 VDC
Load voltage/current	10 to 30 VDC, 5 to 20 mA (*1)	30 VDC or less, 50 mA or less
Indicator lamp	LED (Lit when ON)	
Leakage current	1 mA or less	10 μA or less
Weight	1 m:18 g 3 m:49 g 5 m:80 g	

Descriptions	Reed 2-wire	
	K0H/K0V	K5H/K5V
Applications	For programmable controller, relay	For programmable controller, relay, IC circuit (without indicator lamp), serial connection
Power supply voltage	—	
Load voltage/current	12/24 VDC, 5 to 50 mA 110 VAC, 7 to 20mA	5/12/24 VDC, 50 mA or less 110 VAC, 20 mA or less
Indicator lamp	LED (Lit when ON)	None
Leakage current	0 mA	
Weight	1 m:18 g 3 m:49 g 5 m:80 g	

*1 : The above max. load current is 20 mA at 25°C. The current is lower than 20 mA if the operating ambient temperature around the switch is higher than 25°C. (5 to 10 mA at 60°C)

*2 : Refer to Ending Page 1 for other switch specifications.

LCW
LCR
LCG
LCX
LCM
STM
STG
STS/STL
STR2
UCA2
ULK*
JSK/M2
JSG
JSC3/JSC4
USSD
UFCD
USC
JSB3
LMB
LML
HCM
HCA
LBC
CAC4
UCAC2
CAC-N
UCAC-N
RCC2
RCS
PCC
SHC
MCP
GLC
MFC
BBS
RRC
GRC
RV3*
NHS
HR
LN
Hand
Chuk
MecHnd/Chuk
ShkAbs
FJ
FK
SpdContr
Ending
LSH
FH100
HAP
BSA2
BHA/BHG
LHA
LHAG
HKP
HLA/HLB
HLAG/HLBG
HLD
HCP
HMF
HMFb
HFP
HLC
HGP
FH500
HBL
HDL
HMD
HJD
HJL
BHE

How to order

Without switch (built-in magnet for switch)

HLA - 12CS

With switch (built-in magnet for switch)

HLA - 12CS - K2H - R

A Model No.

B Size

C Switch model No.
*1

D Switch quantity

Code	Content					
A Model No.						
HLA	Bush guide					
HLB	Bearing guide					
B Size						
12CS						
15CS						
20CS						
C Switch model No.						
Axial lead wire	Radial lead wire	Contact	Voltage		Display	Lead wire
			AC	DC		
K0H*	K0V*	Reed	●	●	1-color display	2-wire
K5H*	K5V*		●	●	no indicator lamp	
K2H*	K2V*	Proximity		●	1-color display	2-wire
K3H*	K3V*			●	display	
* Lead wire length						
Blank	1 m (standard)					
3	3 m (option)					
5	5 m (option)					
D Switch quantity						
R	1 on open side					
H	1 on closed side					
D	2					

⚠ Precautions for model No. selection

*1: Switches other than ©Switch model No. are also available. (Custom order)
Refer to Ending Page 1 for details.

[Example of model No.]

HLB-12CS-K2H-R

Model: Thin parallel hand

- A** Model No. : Bearing guide HLB
- B** Size : 12CS
- C** Switch model No. : Proximity K2H switch, lead wire 1 m
- D** Switch quantity : 1 on open side

How to order switch

SW - K2H

↓
Switch model No.
(Item © above)

LCW
LCR
LCG
LCX
LCM
STM
STG
STS/STL
STR2
UCA2
ULK*
JSK/M2
JSG
JSC3/JSC4
USSD
UFCD
USC
JSB3
LMB
LML
HCM
HCA
LBC
CAC4
UCAC2
CAC-N
UCAC-N
RCC2
RCS
PCC
SHC
MCP
GLC
MFC
BBS
RRC
GRC
RV3*
NHS
HR
LN
Hand
Chuk
MecHnd/Chuk
ShkAbs
FJ
FK
SpdContr
Ending
LSH
FH100
HAP
BSA2
BHA/BHG
LHA
LHAG
HKP
HLA/HLB
HLAG/HLBG
HLD
HCP
HMF
HMFB
HFP
HLC
HGP
FH500
HBL
HDL
HMD
HJD
HJL
BHE

HLA/HLB Series

Internal structure and parts list

● HLA-12CS to 20CS

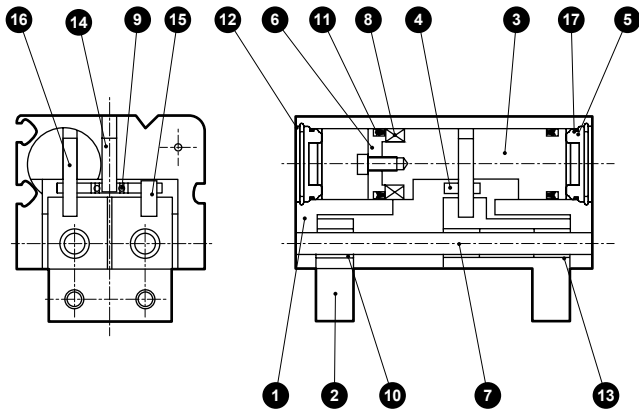

● HLB-12CS to 20CS

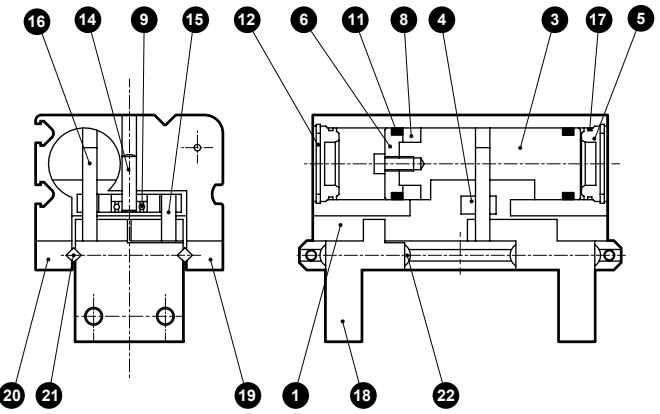

Cannot be disassembled

No.	Part name	Material	Remarks	No.	Part name	Material	Remarks
1	Body	Aluminum alloy		12	Snap ring	Stainless steel	
2	Master key	Aluminum alloy		13	Bush	Sintering oil impregnated alloy	
3	Piston	Stainless steel		14	Parallel pin	Steel	
4	Cam	Stainless steel		15	Needle roller A	Alloy steel	
5	Cylinder guard	Acetal resin		16	Needle roller B	Alloy steel	
6	Magnet holder	Aluminum alloy		17	Cylinder gasket	Nitrile rubber	
7	Guide rod	Alloy steel		18	Master key	Steel	
8	Magnet			19	Bearing guide A	Steel	
9	Small diameter sphere bearing	Alloy steel		20	Bearing guide B	Steel	
10	Bush	Sintering oil impregnated alloy		21	Cross roller	Alloy steel	
11	Piston packing	Nitrile rubber		22	Truss machine screw	Stainless steel	

Gripping power performance data

The gripping power in the opening/closing directions with jaw length L of hand with a supply pressure of 0.3, 0.5 and 0.7 MPa is shown.

● Both open direction (←) and closed direction (→) (shown with continuous line)

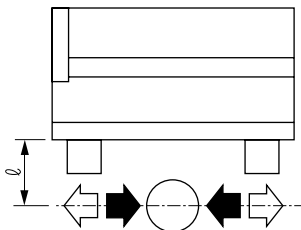

(Note) When making a selection, read the precautions for design and selection on page 1636.

● HLA-20CS

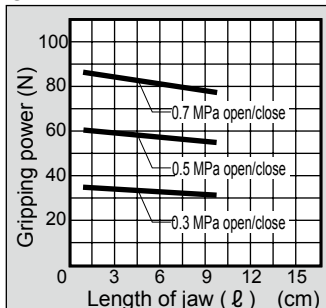

● HLB-12CS

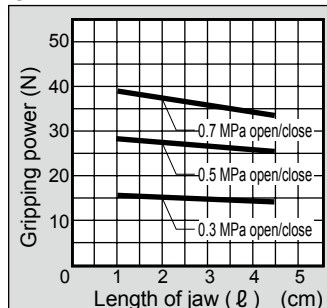

● HLA-12CS

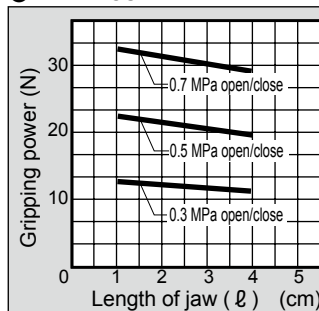

● HLA-15CS

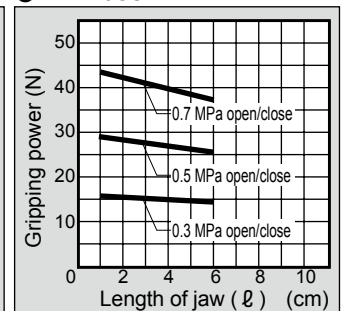

● HLB-15CS

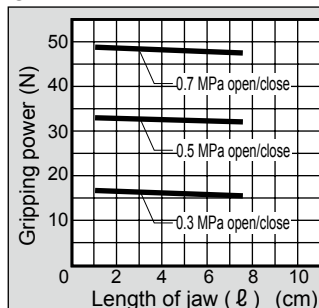

● HLB-20CS

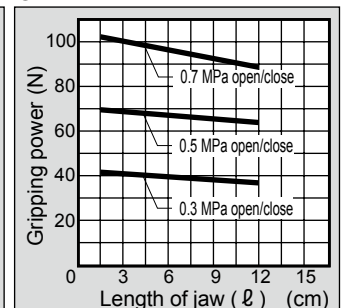

Dimensions



● HLA-12CS Standard

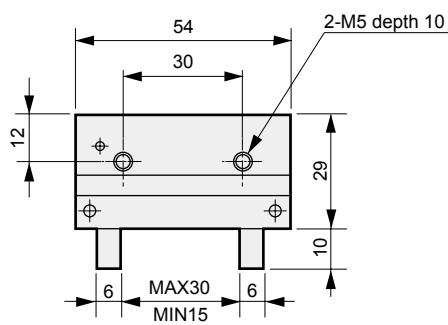
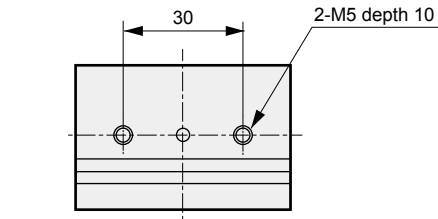

● With switch

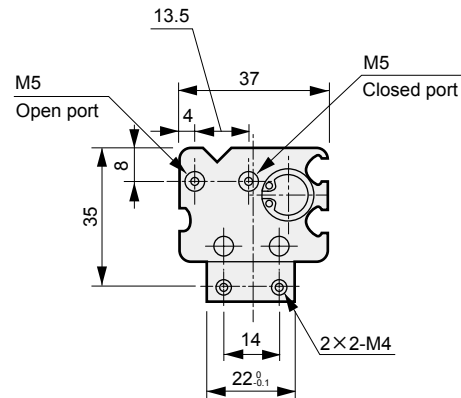
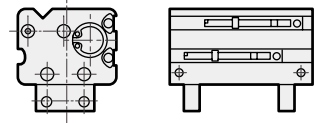

● HLA-15CS Standard

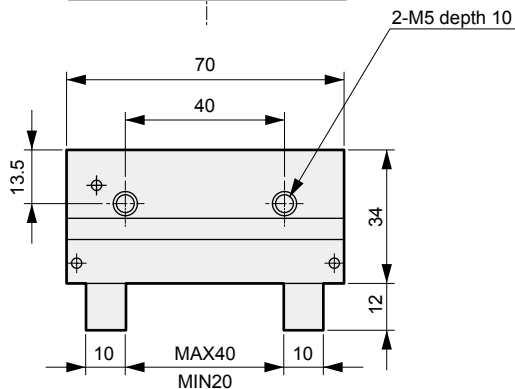
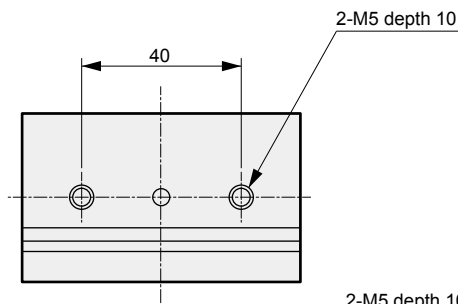

● With switch

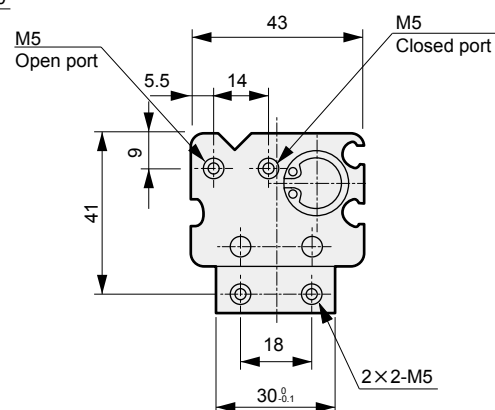
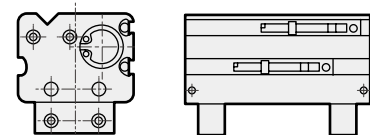

LCW
LCR
LCG
LCX
LCM
STM
STG
STS/STL
STR2
UCA2
ULK*
JSK/M2
JSG
JSC3/JSC4
USSD
UFCD
USC
JSB3
LMB
LML
HCM
HCA
LBC
CAC4
UCAC2
CAC-N
UCAC-N
RCC2
RCS
PCC
SHC
MCP
GLC
MFC
BBS
RRC
GRC
RV3*
NHS
HR
LN
Hand
Chuk
MecHnd/Chuk
ShkAbs
FJ
FK
SpdContr
Ending
LSH
FH100
HAP
BSA2
BHA/BHG
LHA
LHAG
HKP
HLA/HLB
HLAG/HLBG
HLD
HCP
HMF
HMFB
HFP
HLC
HGP
FH500
HBL
HDL
HMD
HJD
HJL
BHE

Dimensions



● HLA-20CS Standard

● With switch

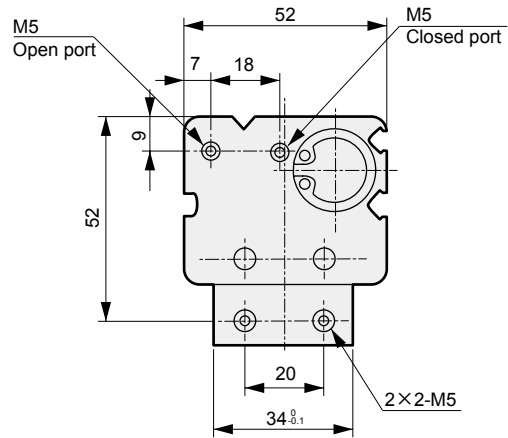
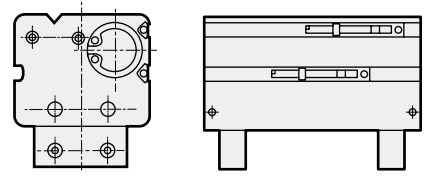
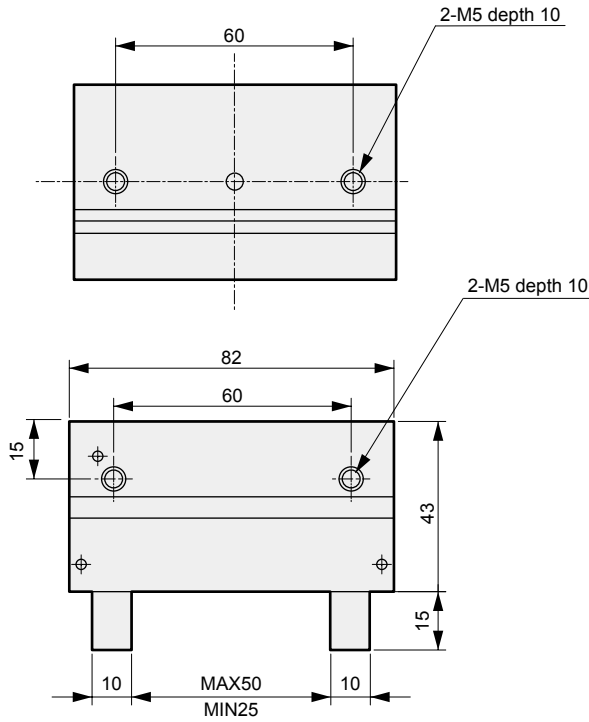

- LCW
- LCR
- LCG
- LCX
- LCM
- STM
- STG
- STS/STL
- STR2
- UCA2
- ULK*
- JSK/M2
- JSG
- JSC3/JSC4
- USSD
- UFCD
- USC
- JSB3
- LMB
- LML
- HCM
- HCA
- LBC
- CAC4
- UCAC2
- CAC-N
- UCAC-N
- RCC2
- RCS
- PCC
- SHC
- MCP
- GLC
- MFC
- BBS
- RRC
- GRC
- RV3*
- NHS
- HR
- LN
- Hand**
- Chuk
- MecHnd/Chuk
- ShkAbs
- FJ
- FK
- SpdContr
- Ending
- LSH
- FH100
- HAP
- BSA2
- BHA/BHG
- LHA
- LHAG
- HKP
- HLA/HLB**
- HLAG/HLBG
- HLD
- HCP
- HMF
- HMFB
- HFP
- HLC
- HGP
- FH500
- HBL
- HDL
- HMD
- HJD
- HJL
- BHE

Dimensions



● HLB-12CS Standard

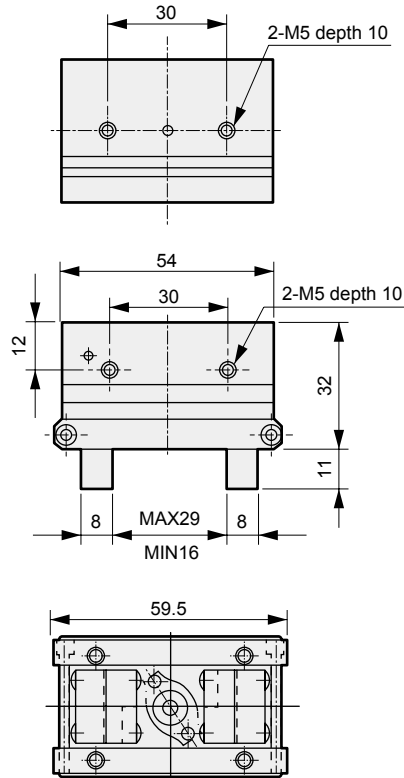

● With switch

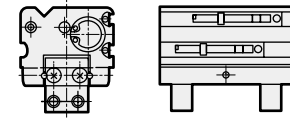
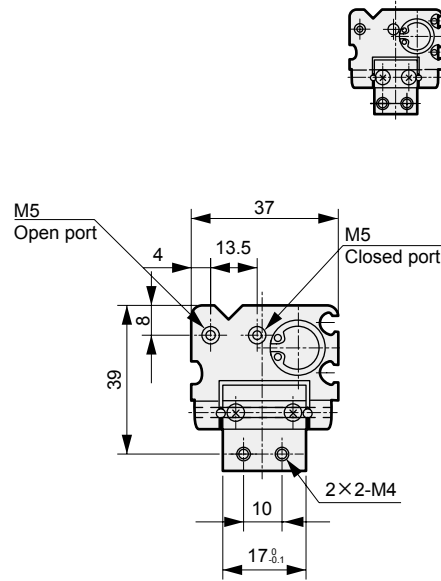

● HLB-15CS Standard

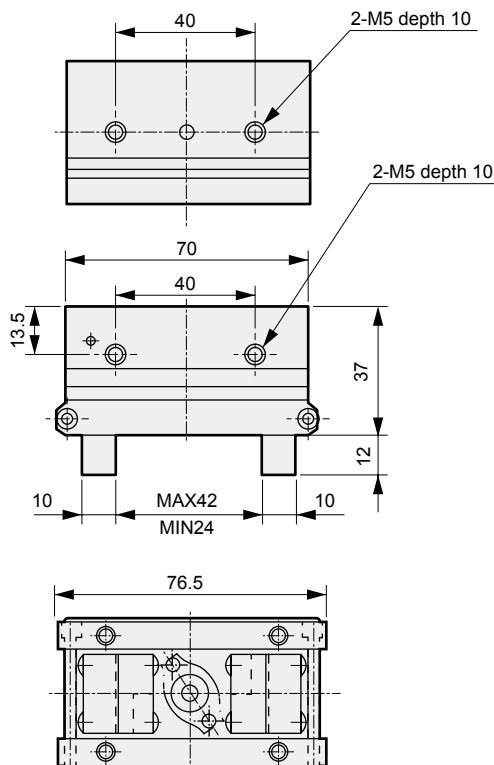

● With switch

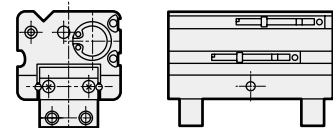
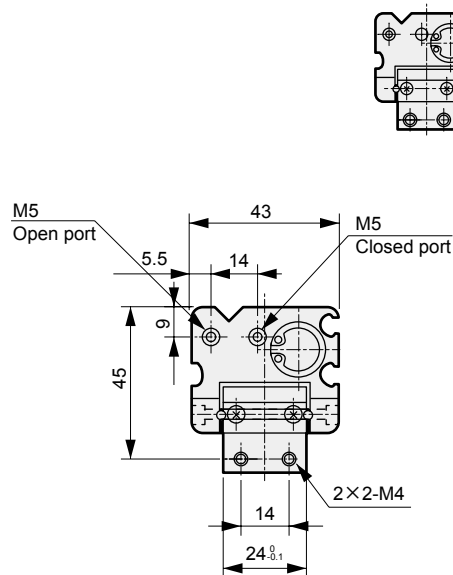

LCW
LCR
LCG
LCX
LCM
STM
STG
STS/STL
STR2
UCA2
ULK*
JSK/M2
JSG
JSC3/JSC4
USSD
UFCD
USC
JSB3
LMB
LML
HCM
HCA
LBC
CAC4
UCAC2
CAC-N
UCAC-N
RCC2
RCS
PCC
SHC
MCP
GLC
MFC
BBS
RRC
GRC
RV3*
NHS
HR
LN
Hand
Chuk
MecHnd/Chuk
ShkAbs
FJ
FK
SpdContr
Ending
LSH
FH100
HAP
BSA2
BHA/BHG
LHA
LHAG
HKP
HLA/HLB
HLAG/HLBG
HLD
HCP
HMF
HMFB
HFP
HLC
HGP
FH500
HBL
HDL
HMD
HJD
HJL
BHE

HLB Series

Dimensions



● HLB-20CS Standard

● With switch

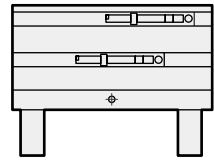
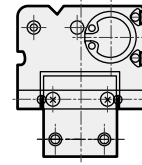
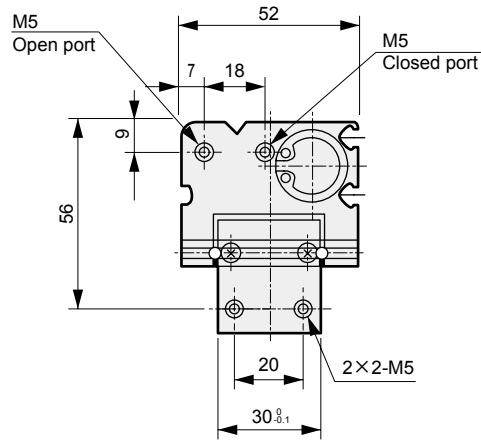
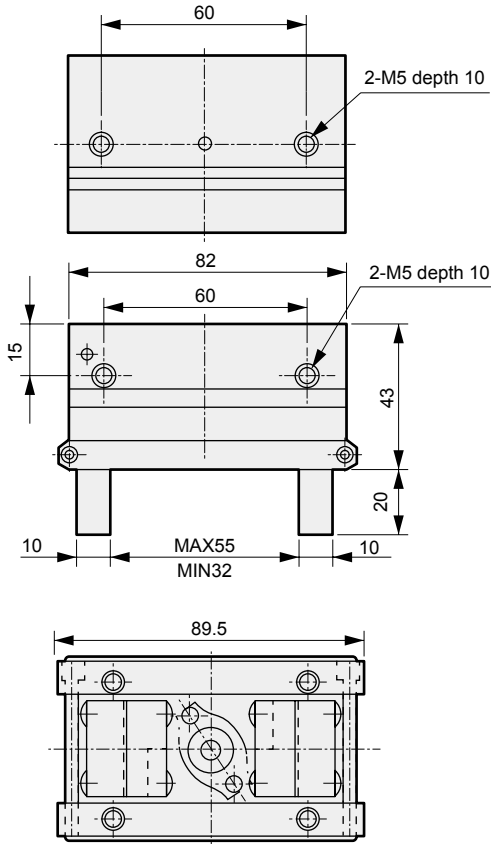

- LCW
- LCR
- LCG
- LCX
- LCM
- STM
- STG
- STS/STL
- STR2
- UCA2
- ULK*
- JSK/M2
- JSG
- JSC3/JSC4
- USSD
- UFCD
- USC
- JSB3
- LMB
- LML
- HCM
- HCA
- LBC
- CAC4
- UCAC2
- CAC-N
- UCAC-N
- RCC2
- RCS
- PCC
- SHC
- MCP
- GLC
- MFC
- BBS
- RRC
- GRC
- RV3*
- NHS
- HR
- LN
- Hand**
- Chuk
- MecHnd/Chuk
- ShkAbs
- FJ
- FK
- SpdContr
- Ending
- LSH
- FH100
- HAP
- BSA2
- BHA/BHG
- LHA
- LHAG
- HKP
- HLA/HLB**
- HLAG/HLBG
- HLD
- HCP
- HMF
- HMFB
- HFP
- HLC
- HGP
- FH500
- HBL
- HDL
- HMD
- HJD
- HJL
- BHE

MEMO

LCW
LCR
LCG
LCX
LCM
STM
STG
STS/STL
STR2
UCA2
ULK*
JSK/M2
JSG
JSC3/JSC4
USSD
UFCD
USC
JSB3
LMB
LML
HCM
HCA
LBC
CAC4
UCAC2
CAC-N
UCAC-N
RCC2
RCS
PCC
SHC
MCP
GLC
MFC
BBS
RRC
GRC
RV3*
NHS
HR
LN
Hand
Chuk
MecHnd/Chuk
ShkAbs
FJ
FK
SpdContr
Ending
LSH
FH100
HAP
BSA2
BHA/BHG
LHA
LHAG
HKP
HLA/HLB
HLAG/HLBG
HLD
HCP
HMF
HMFB
HFP
HLC
HGP
FH500
HBL
HDL
HMD
HJD
HJL
BHE

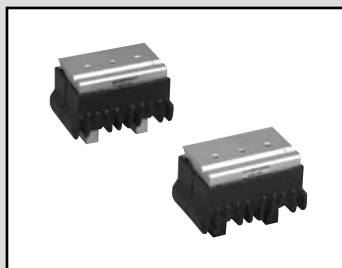

Thin parallel hand with rubber cover (bush/bearing guide)
Double acting

HLAG/HLBG Series

- Operational stroke length: HLAG 15, 20, 25 mm
HLBG 13, 18, 23 mm

Double acting



Specifications

Descriptions	HLAG-12CS	HLAG-15CS	HLAG-20CS	HLBG-12CS	HLBG-15CS	HLBG-20CS
Bore size mm	φ12	φ15	φ20	φ12	φ15	φ20
Actuation	Double acting					
Working fluid	Compressed air					
Max. working pressure MPa	0.7 (≈100 psi, 7 bar)					
Min. working pressure MPa	0.3 (≈44 psi, 3 bar)			0.2 (≈29 psi, 2 bar)		
Ambient temperature °C	5 (41°F) to 60 (140°F)					
Port size	M5					
Operating stroke length mm	15	20	25	13	18	23
Volumetric capacity (reciprocating) cm ³	1.69	3.53	7.85	1.47	3.18	7.22
Repeatability mm	±0.03			±0.01		
Weight kg	0.175	0.305	0.545	0.24	0.42	0.75
Lubrication	Not required (use turbine oil class 1 ISO VG32 if necessary for lubrication)					

Switch specifications

Descriptions	Proximity 2-wire	Proximity 3-wire
	K2H	K3H
Applications	Dedicated for programmable controller	For programmable controller, relay
Output method	—	NPN output
Power supply voltage	—	10 to 28 VDC
Load voltage/current	10 to 30 VDC, 5 to 20 mA (*1)	30 VDC or less, 50 mA or less
Indicator lamp	LED (Lit when ON)	
Leakage current	1 mA or less	10 μA or less
Weight	1 m:18 g 3 m:49 g 5 m:80 g	

Descriptions	Reed 2-wire	
	K0H	K5H
Applications	For programmable controller, relay	For programmable controller, relay, IC circuit (without indicator lamp), serial connection
Power supply voltage	—	
Load voltage/current	12/24 VDC, 5 to 50 mA 110 VAC, 7 to 20 mA	5/12/24 VDC, 50 mA or less 110 VAC, 20 mA or less
Indicator lamp	LED (Lit when ON)	None
Leakage current	0 mA	
Weight	1 m:18 g 3 m:49 g 5 m:80 g	

*1 : The above max. load current is 20 mA at 25°C. If the operating ambient temperature around the switch is higher than 25°C, the current is lower than 20 mA. (5 to 10 mA at 60°C)

*2 : Refer to Ending Page 1 for other switch specifications.

LCW
LCR
LCG
LCX
LCM
STM
STG
STS/STL
STR2
UCA2
ULK*
JSK/M2
JSG
JSC3/JSC4
USSD
UFCD
USC
JSB3
LMB
LML
HCM
HCA
LBC
CAC4
UCAC2
CAC-N
UCAC-N
RCC2
RCS
PCC
SHC
MCP
GLC
MFC
BBS
RRC
GRC
RV3*
NHS
HR
LN
Hand
Chuk
MecHnd/Chuk
ShkAbs
FJ
FK
SpdContr
Ending
LSH
FH100
HAP
BSA2
BHA/BHG
LHA
LHAG
HKP
HLA/HLB
HLAG/HLBG
HLD
HCP
HMF
HMFb
HFP
HLC
HGP
FH500
HBL
HDL
HMD
HJD
HJL
BHE

How to order

Without switch (built-in magnet for switch)

HLAG - 12CS

With switch (built-in magnet for switch)

HLAG - 12CS - K2H - R

A Model No.

B Size

C Switch model No.

D Switch quantity

[Example of model No.]

HLAG-12CS-K2H-R

Model: Rubber covered thin parallel hand

- A** Model No. : Bush guide HLAG
- B** Size : 12CS
- C** Switch model No.: Proximity switch K2H, lead wire 1 m
- D** Switch quantity : 1 on open side

Code	Content			
A Model No.				
HLAG	Bush guide			
HLBG	Bearing guide			
B Size				
12CS				
15CS				
20CS				
C Switch model No.				
Axial lead wire	Contact	Voltage	Display	Lead wire
		AC DC		
K0H*	Reed	● ●	1-color display	2-wire
K5H*		● ●	no indicator lamp	
K2H*	Proximity	●	1-color	2-wire
K3H*		●	display	
* Lead wire length				
Blank	1 m (standard)			
3	3 m (option)			
5	5 m (option)			
D Switch quantity				
R	1 on open side			
H	1 on closed side			
D	2			

How to order switch

SW - K2H

Switch model No.
(Item **C** above)

Specifications for rechargeable battery (Catalog No. CC-1226A)

HLBG - ... - P4* ● Design compatible with rechargeable battery manufacturing process.

* Contact CKD for details.

LCW
LCR
LCC
LCX
LCM
STM
STG
STS/STL
STR2
UCA2
ULK*
JSK/M2
JSG
JSC3/JSC4
USSD
UFCD
USC
JSB3
LMB
LML
HCM
HCA
LBC
CAC4
UCAC2
CAC-N
UCAC-N
RCC2
RCS
PCC
SHC
MCP
GLC
MFC
BBS
RRC
GRC
RV3*
NHS
HR
LN
Hand
Chuk
MecHnd/Chuk
ShkAbs
FJ
FK
SpdContr
Ending
LSH
FH100
HAP
BSA2
BHA/BHG
LHA
LHAG
HKP
HLA/HLB
HLAG/HLBG
HLD
HCP
HMF
HMFB
HFP
HLC
HGP
FH500
HBL
HDL
HMD
HJD
HJL
BHE

HLAG/HLBG Series

Internal structure and parts list

● HLAG-12CS to 20CS

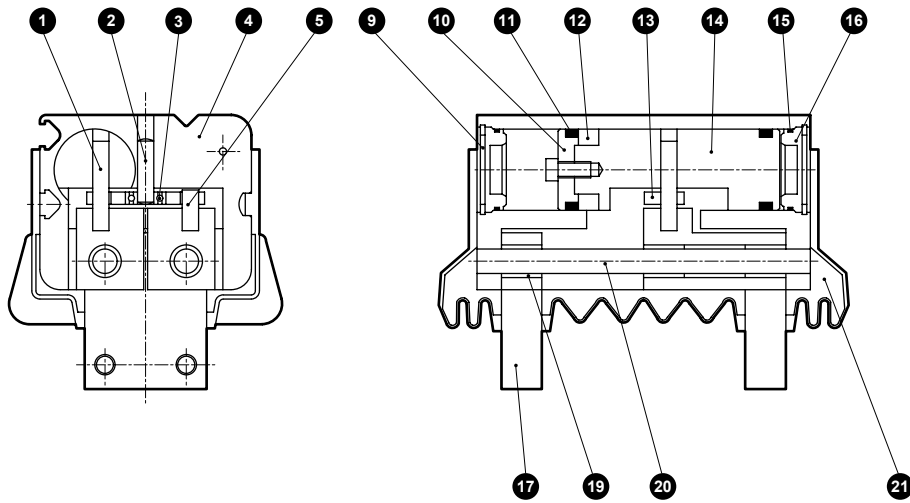

● HLBG-12CS to 20CS

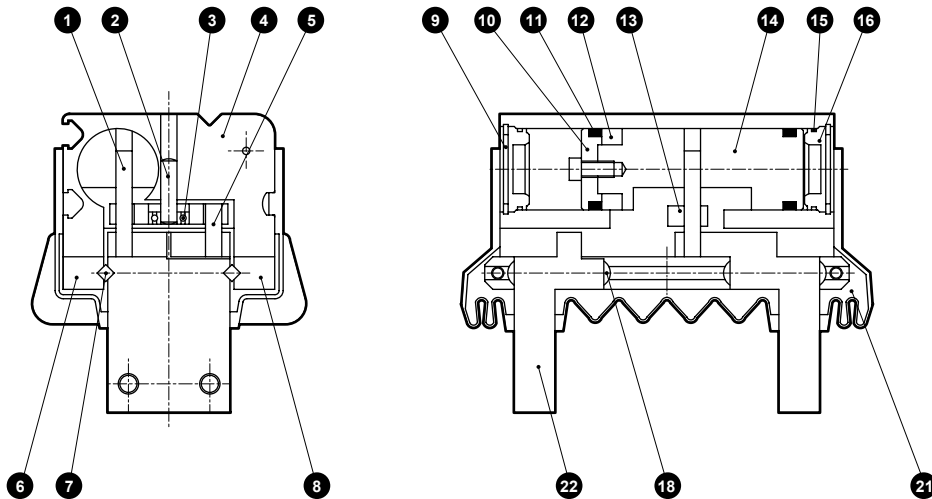

Cannot be disassembled

Parts list

No.	Part name	Material	Remarks	No.	Part name	Material	Remarks
1	Needle roller B	High carbon chrome bearing steel		12	Magnet		
2	Parallel pin	Steel		13	Cam	Stainless steel	
3	Small diameter sphere bearing	Alloy steel		14	Piston	Stainless steel	
4	Body	Aluminum alloy		15	Cylinder gasket	Nitrile rubber	
5	Needle roller A	High carbon chrome bearing steel		16	Cylinder guard	Resin	
6	Bearing guide B	Steel		17	Master key	Aluminum alloy	
7	Cross roller	High carbon chrome bearing steel		18	Truss machine screw	Stainless steel	
8	Bearing guide A	Steel		19	Bush	Sintering oil impregnated alloy	
9	Snap ring	Stainless steel		20	Guide rod	High carbon chrome bearing steel	
10	Magnet holder	Aluminum alloy		21	Rubber cover	Nitrile rubber	
11	Piston packing	Nitrile rubber		22	Master key	Steel	

- LCW
- LCR
- LCG
- LCX
- LCM
- STM
- STG
- STS/STL
- STR2
- UCA2
- ULK*
- JSK/M2
- JSG
- JSC3/USC4
- USSD
- UFCD
- USC
- JSB3
- LMB
- LML
- HCM
- HCA
- LBC
- CAC4
- UCAC2
- CAC-N
- UCAC-N
- RCC2
- RCS
- PCC
- SHC
- MCP
- GLC
- MFC
- BBS
- RRC
- GRC
- RV3*
- NHS
- HR
- LN
- Hand**
- Chuk
- MecHnd/Chuk
- ShkAbs
- FJ
- FK
- SpdContr
- Ending

- LSH
- FH100
- HAP
- BSA2
- BHA/BHG
- LHA
- LHAG
- HKP
- HLA/HLB
- HLAG/HLBG**
- HLD
- HCP
- HMF
- HMFB
- HFP
- HLC
- HGP
- FH500
- HBL
- HDL
- HMD
- HJD
- HJL
- BHE

Gripping power performance data

The gripping power in the opening/closing directions with jaw length L of hand with a supply pressure of 0.3, 0.5 and 0.7 MPa is shown.

- Both open direction (↔) and closed direction (◀▶) (shown with continuous line)

(Note) When making a selection, read the precautions for design and selection on page 1636.

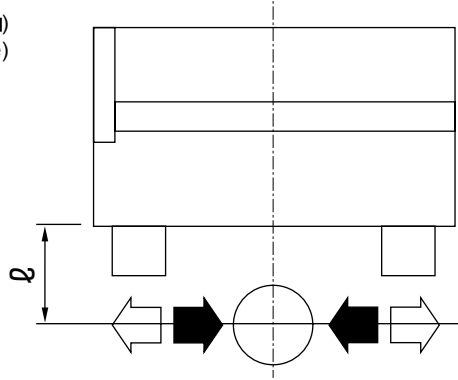

● HLAG-12CS

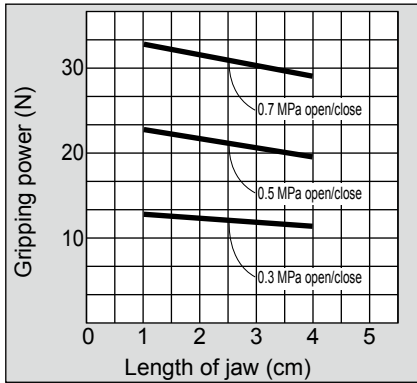

● HLAG-15CS

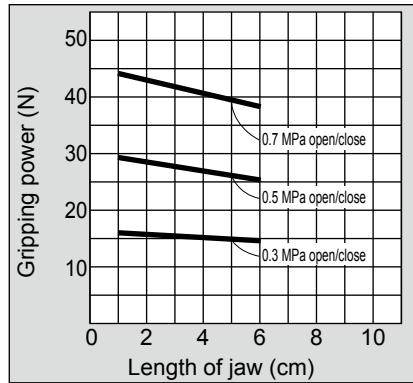

● HLAG-20CS

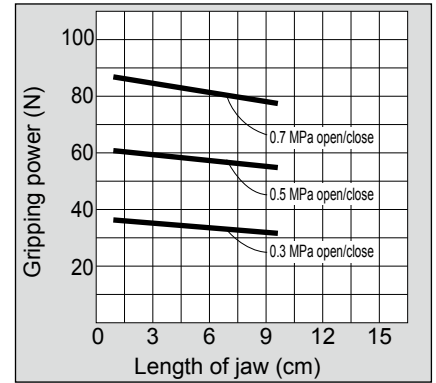

● HLBG-12CS

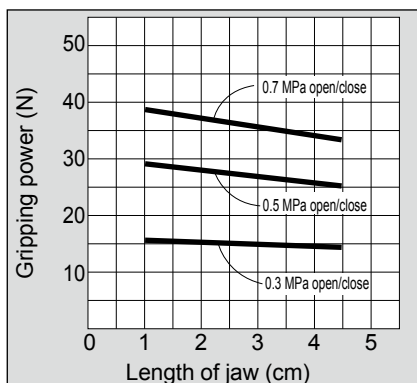

● HLBG-15CS

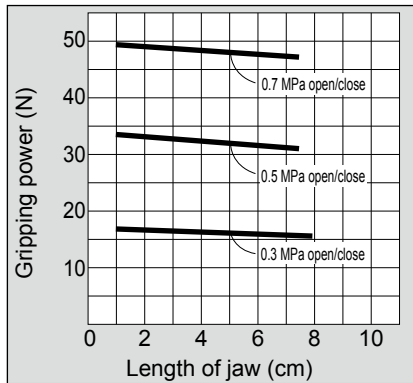

● HLBG-20CS

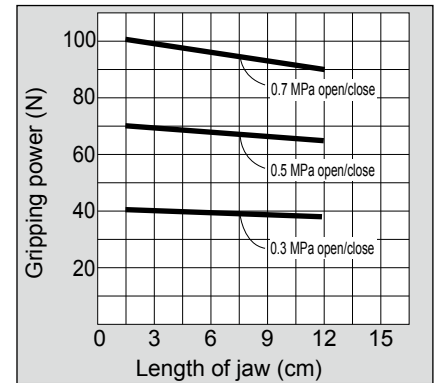

LCW
LCR
LCG
LCX
LCM
STM
STG
STS/STL
STR2
UCA2
ULK*
JSK/M2
JSG
JSC3/JSC4
USSD
UFCD
USC
JSB3
LMB
LML
HCM
HCA
LBC
CAC4
UCAC2
CAC-N
UCAC-N
RCC2
RCS
PCC
SHC
MCP
GLC
MFC
BBS
RRC
GRC
RV3*
NHS
HR
LN
Hand
Chuk
MecHnd/Chuk
ShkAbs
FJ
FK
SpdContr
Ending
LSH
FH100
HAP
BSA2
BHA/BHG
LHA
LHAG
HKP
HLA/HLB
HLAG/HLBG
HLD
HCP
HMF
HMFB
HFP
HLC
HGP
FH500
HLB
HDL
HMD
HJD
HJL
BHE

HLAG Series

Dimensions



● HLAG-12CS Standard

● With switch

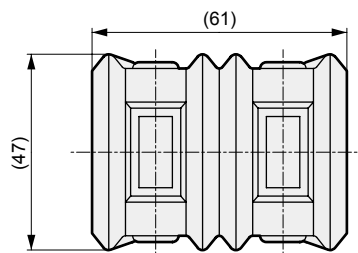
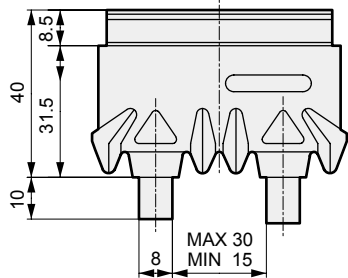
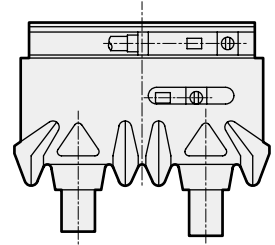
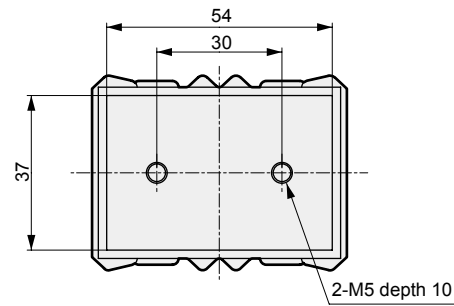
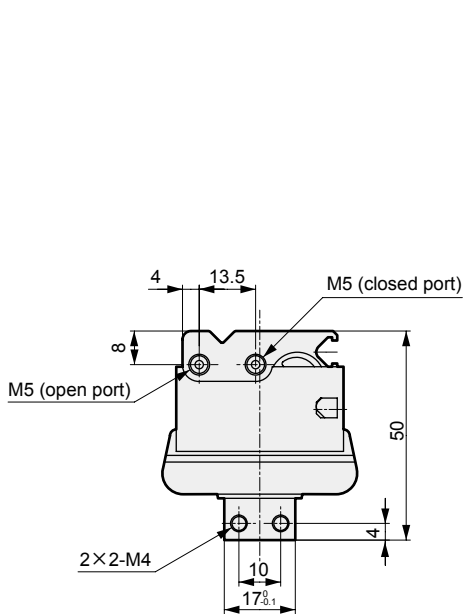

● HLAG-15CS Standard

● With switch

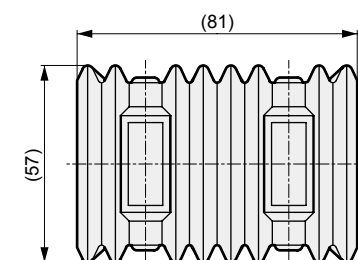
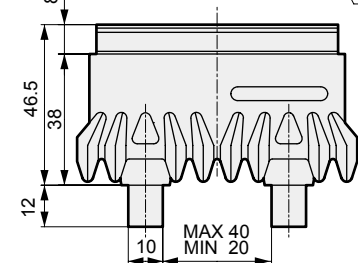
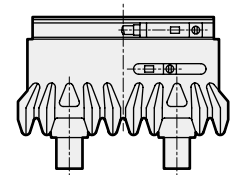
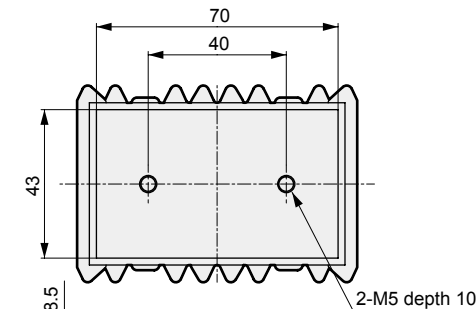
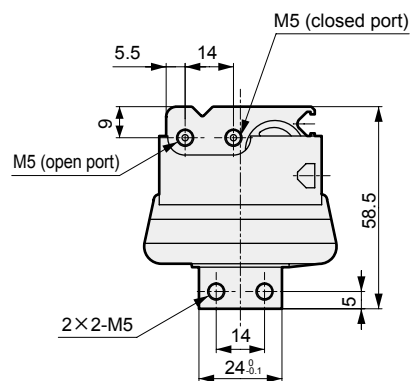

- LCW
- LCR
- LCG
- LCX
- LCM
- STM
- STG
- STS/STL
- STR2
- UCA2
- ULK*
- JSK/M2
- JSG
- JSC3/JSC4
- USSD
- UFCD
- USC
- JSB3
- LMB
- LML
- HCM
- HCA
- LBC
- CAC4
- UCAC2
- CAC-N
- UCAC-N
- RCC2
- RCS
- PCC
- SHC
- MCP
- GLC
- MFC
- BBS
- RRC
- GRC
- RV3*
- NHS
- HR
- LN
- Hand**
- Chuk
- MecHnd/Chuk
- ShkAbs
- FJ
- FK
- SpdContr
- Ending
- LSH
- FH100
- HAP
- BSA2
- BHA/BHG
- LHA
- LHAG
- HKP
- HLA/HLB
- HLAG/HLBG**
- HLD
- HCP
- HMF
- HMFB
- HFP
- HLC
- HGP
- FH500
- HBL
- HDL
- HMD
- HJD
- HJL
- BHE

Dimensions

● HLAG-20CS Standard

● With switch

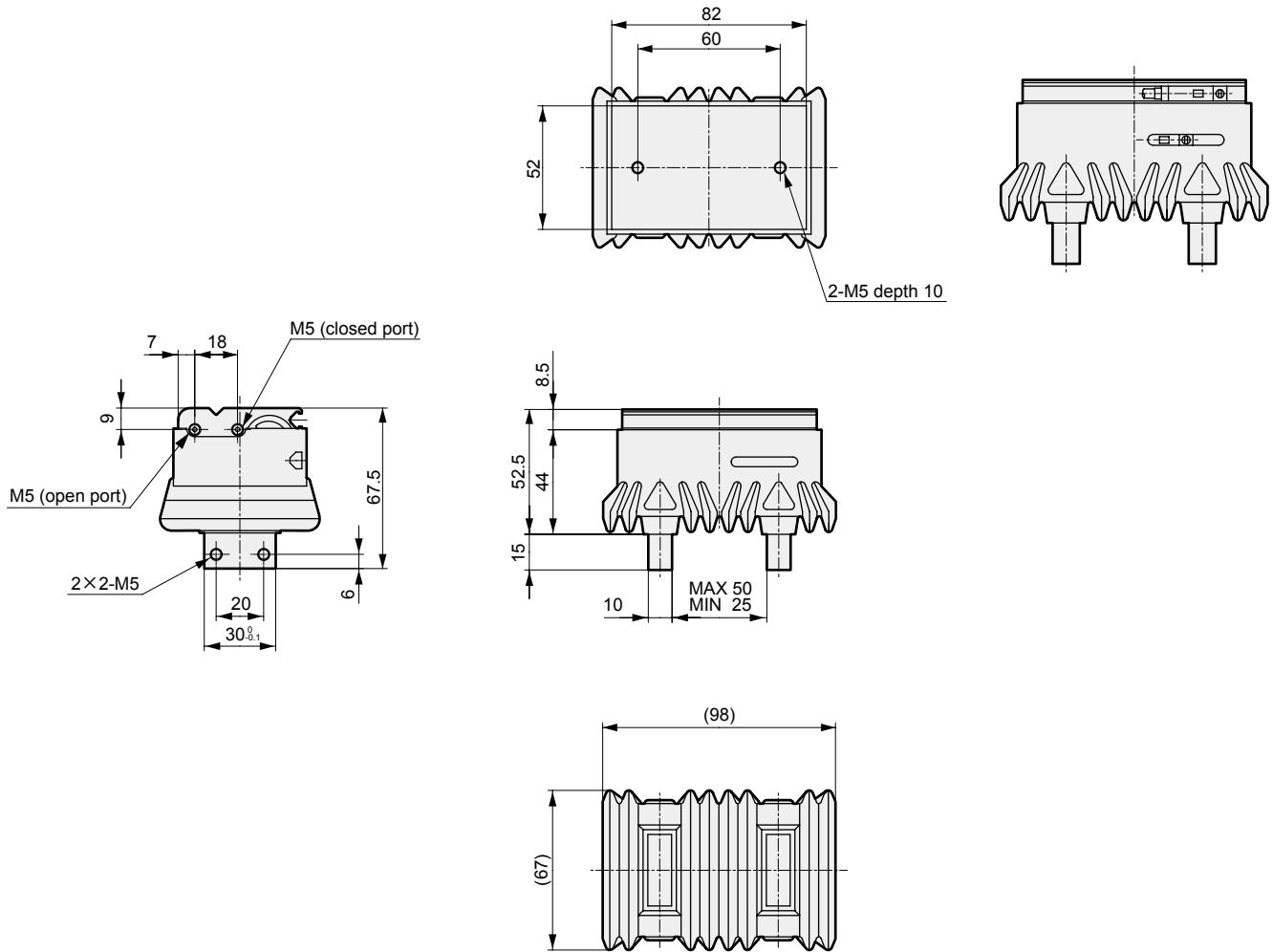

LCW
LCR
LCG
LCX
LCM
STM
STG
STS/STL
STR2
UCA2
ULK*
JSK/M2
JSG
JSC3/JSC4
USSD
UFCD
USC
JSB3
LMB
LML
HCM
HCA
LBC
CAC4
UCAC2
CAC-N
UCAC-N
RCC2
RCS
PCC
SHC
MCP
GLC
MFC
BBS
RRC
GRC
RV3*
NHS
HR
LN
Hand
Chuk
MecHnd/Chuk
ShkAbs
FJ
FK
SpdContr
Ending
LSH
FH100
HAP
BSA2
BHA/BHG
LHA
LHAG
HKP
HLA/HLB
HLAG/HLBG
HLD
HCP
HMF
HMFB
HFP
HLC
HGP
FH500
HBL
HDL
HMD
HJD
HJL
BHE

HLBG Series

Dimensions



● HLBG-12CS Standard

● With switch

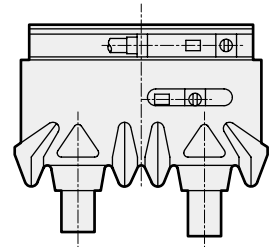
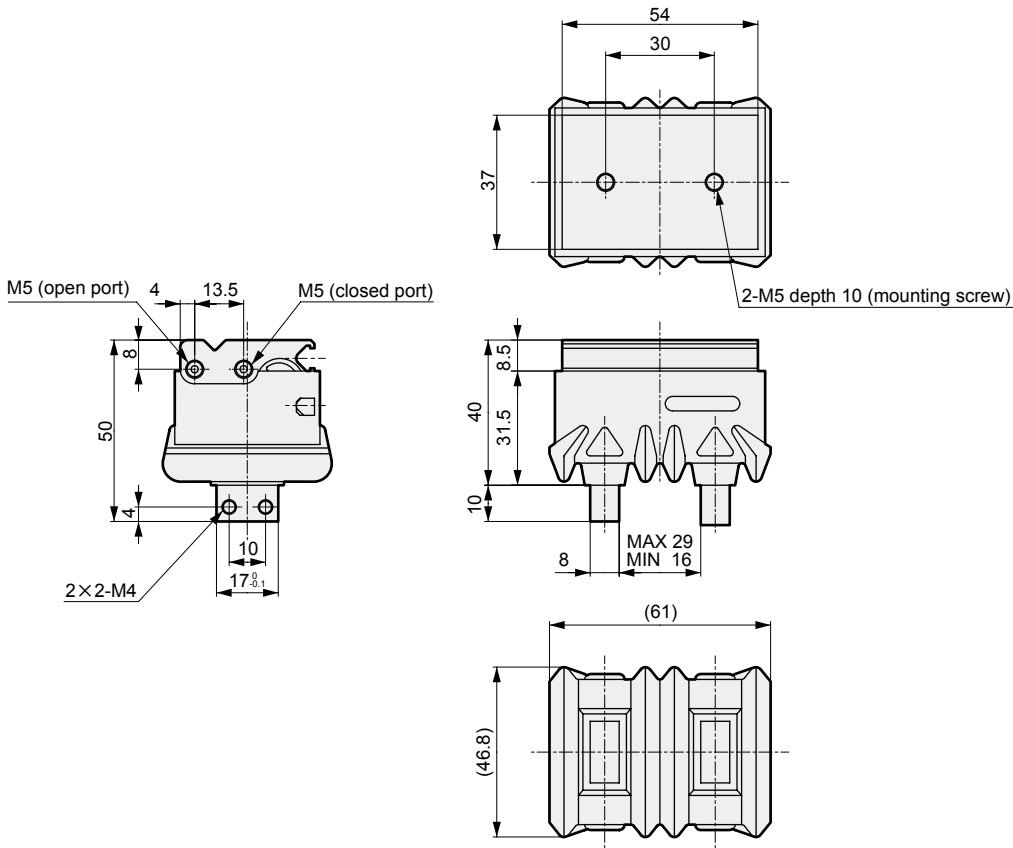

● HLBG-15CS Standard

● With switch

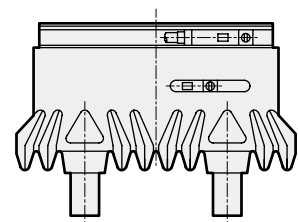
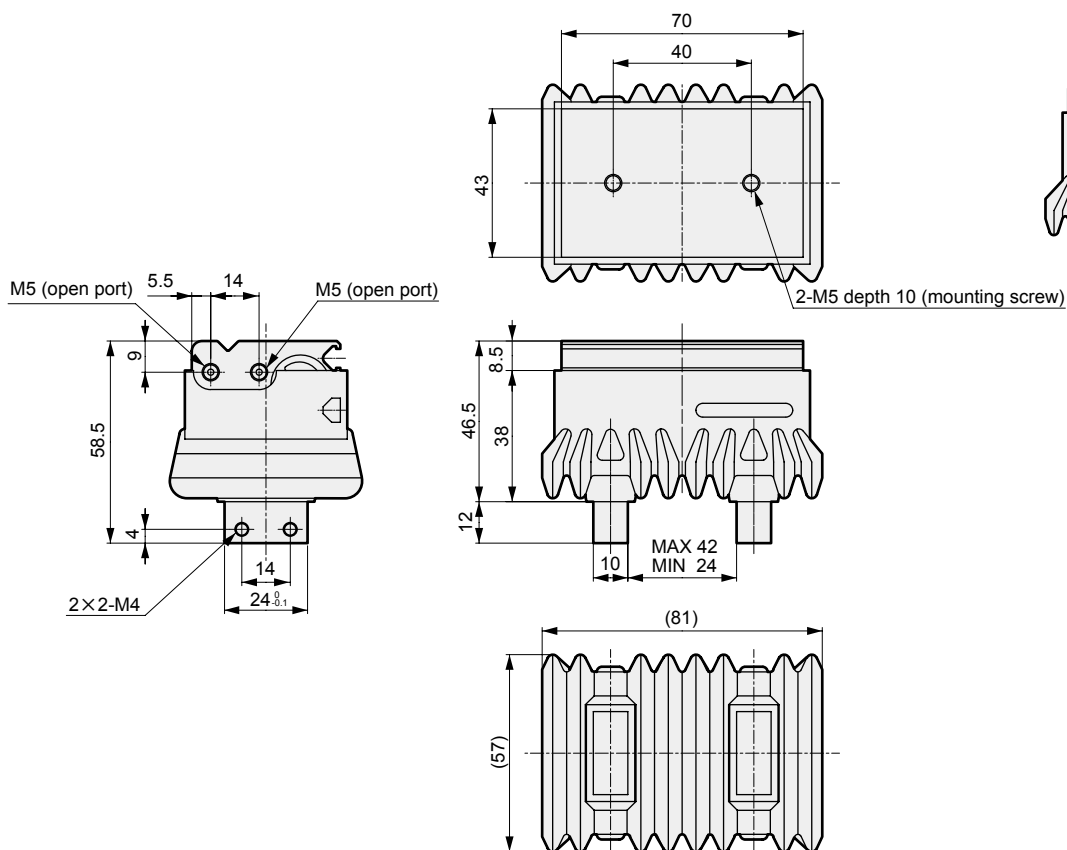

- LCW
- LCR
- LCG
- LCX
- LCM
- STM
- STG
- STS/STL
- STR2
- UCA2
- ULK*
- JSK/M2
- JSG
- JSC3/JSC4
- USSD
- UFCD
- USC
- JSB3
- LMB
- LML
- HCM
- HCA
- LBC
- CAC4
- UCAC2
- CAC-N
- UCAC-N
- RCC2
- RCS
- PCC
- SHC
- MCP
- GLC
- MFC
- BBS
- RRC
- GRC
- RV3*
- NHS
- HR
- LN
- Hand
- Chuk
- MecHnd/Chuk
- ShkAbs
- FJ
- FK
- SpdContr
- Ending
- LSH
- FH100
- HAP
- BSA2
- BHA/BHG
- LHA
- LHAG
- HKP
- HLA/HLB
- HLAG/HLBG
- HLD
- HCP
- HMF
- HMFB
- HFP
- HLC
- HGP
- FH500
- HBL
- HDL
- HMD
- HJD
- HJL
- BHE

Dimensions



● HLBG-20CS Standard

● With switch

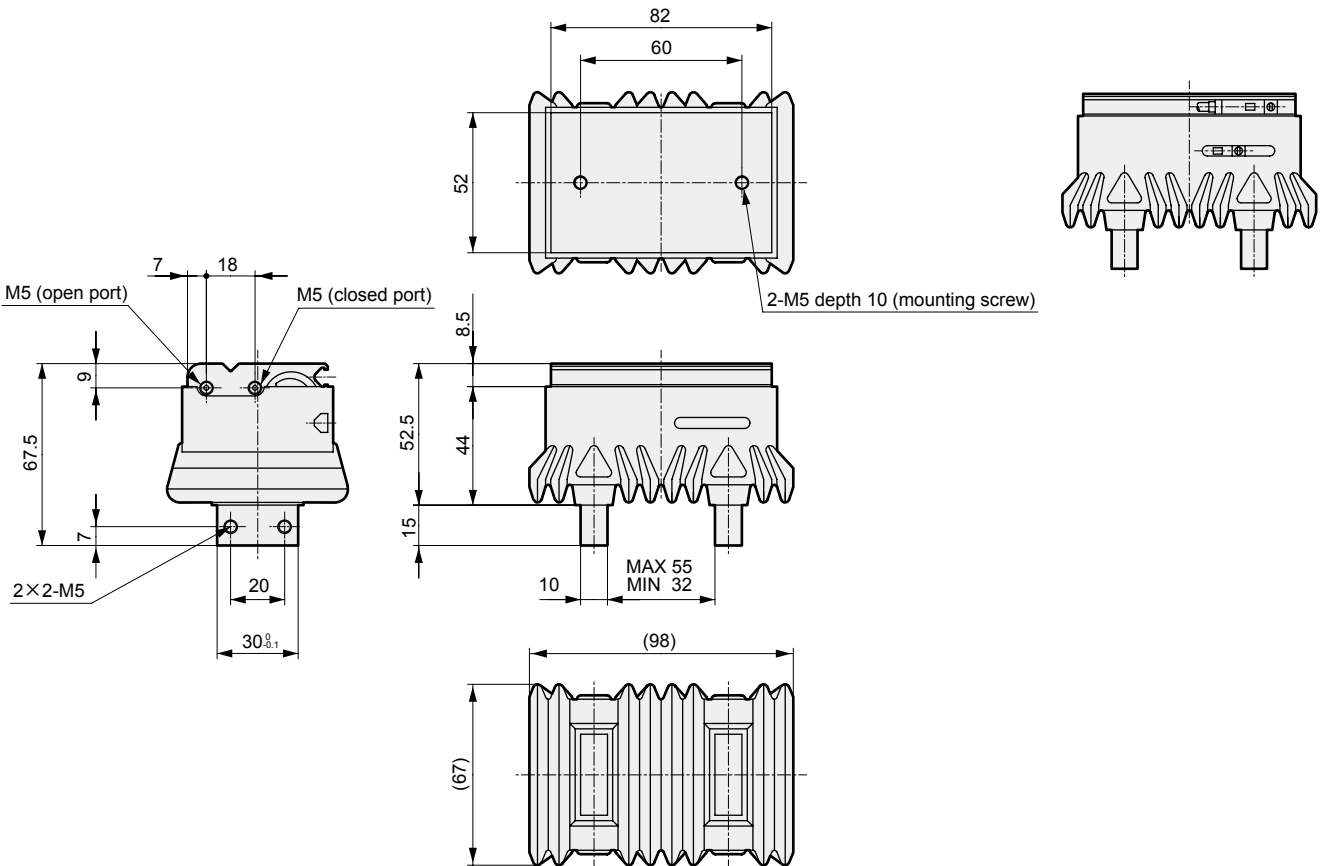

LCW
LCR
LCG
LCX
LCM
STM
STG
STS/STL
STR2
UCA2
ULK*
JSK/M2
JSG
JSC3/JSC4
USSD
UFCD
USC
JSB3
LMB
LML
HCM
HCA
LBC
CAC4
UCAC2
CAC-N
UCAC-N
RCC2
RCS
PCC
SHC
MCP
GLC
MFC
BBS
RRC
GRC
RV3*
NHS
HR
LN
Hand
Chuk
MecHnd/Chuk
ShkAbs
FJ
FK
SpdContr
Ending
LSH
FH100
HAP
BSA2
BHA/BHG
LHA
LHAG
HKP
HLA/HLB
HLAG/HLBG
HLD
HCP
HMF
HMFB
HFP
HLC
HGP
FH500
HBL
HDL
HMD
HJD
HJL
BHE