

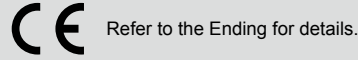

Direct acting 2-port solenoid valve for compressed air, single unit  
(Special purpose valve)

# FAB Series

- NC, NO
- Port size: M5, Rc1/8 to Rc1/2



- EXA
- FWD
- HNB/G
- USB/G
- FAB/G
- FGB/G
- FVB
- FWB/G
- FHB
- FLB
- AB
- AG
- AP/AD
- APK/ADK
- DryAir
- EX-XPLNprf
- XPLNprf
- HVB/HVL
- SAB/NAB
- LAD/NAD
- Water-Rela
- NP/NAP/NVP
- SNP
- CHB/G
- MXB/G
- Other valves
- SWD/MWD
- DustColl
- CVE/CVSE
- CCH/CPE/D
- LifeSci
- Gas-Combus
- Auto-Water
- SpecFld
- Custom
- Ending

## JIS symbol

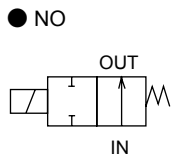
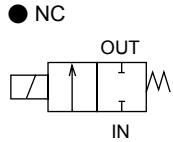

## Common specifications

Descriptions	FAB
Working fluid	Compressed air
Working pressure differential MPa	0 (≈0 psi, 0 bar) to 1.4 (≈200 psi, 14 bar) (refer to the max. working pressure differential in the individual specifications)
Proof pressure (water pressure) MPa	2.1 (≈300 psi, 21 bar) (1.5 (≈220 psi, 15 bar) for FAB11/21)
Fluid temperature °C	AC: -10 (14°F) to 60 (140°F), DC: -10 (14°F) to 40 (104°F) (no freezing)
Ambient temperature °C	AC: -20 (-4°F) to 60 (140°F), DC: -20 (-4°F) to 40 (104°F)
Thermal class	Class 130 (B)
Atmosphere	Place free of corrosive gas and explosive gas
Valve structure	Direct acting poppet structure
Valve seat leakage cm <sup>3</sup> /min(ANR)	0.2 or less
Mounting orientation	Unrestricted
Degree of protection	IP65 or equivalent (*1)

\*1 : The T type terminal box is IP61 or equivalent, and the FAB11 compact terminal box is IP40 or equivalent.

## Individual specifications

1 MPa ≈ 145.0 psi, 1 MPa = 10 bar

Descriptions	Port size	Orifice size (mm)	Flow characteristics		Max. working press diff MPa		Max. working pressure MPa	Rated voltage	Apparent power (VA)				Power consumption (W)		Weight (kg)	
			C <sub>v</sub> [dm <sup>3</sup> /(s·bar)]	b	AC	DC			When holding	When starting	AC	DC				
Model No.									50 Hz	60 Hz	50 Hz	60 Hz	50/60 Hz	DC		
NC																
FAB11-	M5	Z	1	0.12	0.64	0.7	0.7	1.0	100 VAC	3.4	2.6	5	4.6	2.3/1.6	3	0.07
		-1	1.5	0.28	0.52	0.3	0.3									
FAB21-	6	-1	1.5	0.28	0.52	1.0	1.0	1.0	100 VAC	5.3	3.7	10	9	2.7/2	4	0.12
		-2	2	0.55	0.59	0.6	0.6									
FAB31-	6	-2	2	0.55	0.56	1.4	1.4	1.4	100 VAC	7.5	5.5	20	17	4/3.4	6.5	0.21
		-3	3	1.2	0.56	1.0	0.6									
FAB41-	8	-3	3	1.2	0.56	1.4	1.4	1.4	200 VAC	15	11	40	35	7.5/6.5	8	0.37
		-6	5	3.1	0.50	0.3	0.15									
FAB41-	8	-5	4	2.1	0.54	1.0	0.9	1.4	24 VDC	15	11	40	35	7.5/6.5	8	0.37
		-7	7	5.7	0.48	0.25	0.15									
FAB51-	10	-5	4	2.1	0.54	1.2	1.2	1.4	12 VDC	20	16	55	45	11/9.5	11.5	0.60
		-6	5	3.1	0.50	0.7	0.8									
FAB51-	10	-7	7	5.7	0.48	0.3	0.3	1.4	12 VDC	20	16	55	45	11/9.5	11.5	0.60
		-8	10	5.5	0.41	0.15	0.15									
NO																
FAB32-	6	-2	2	0.57	0.53	1.1	1.1	1.4	100 VAC	11.5	8	25	22	4.6/3.2	6	0.31
		-3	3	1.2	0.57	0.55	0.55									
FAB42-	8	-3	3	1.2	0.50	0.9	0.9	1.4	200 VAC	18	14	45	40	7.5/6.5	8	0.54
		-5	4	2.1	0.54	0.55	0.55									
FAB52-	8	-5	4	2.1	0.54	0.8	0.8	1.4	24 VDC	25	20	60	50	11/10	11.5	0.71
		-6	5	3.0	0.52	0.5	0.5									
		-7	7	5.2	0.41	0.25	0.25									

\*1 : The voltage fluctuation range must be within ±10% of the rated voltage.

\*2 : The leakage current must be less than or equal to the values shown on the right.

\*3 : 8.6 (W) for 12 VDC.

\*4 : Effective cross-sectional area S and sonic conductance C are converted as  $S \approx 5.0 \times C$ .

\*5 : The 100 VAC (50/60 Hz) can be used with 110 VAC (60 Hz).  
The 200 VAC (50/60 Hz) can be used with 220 VAC (60 Hz).

Leakage current	Voltage	100 VAC	200 VAC	24 VDC	12 VDC
	Model No.				
	FAB1	2 mA or less	1 mA or less	1 mA or less	2 mA or less
	FAB2	3 mA or less	1.5 mA or less		
	FAB3/4/5	6 mA or less	3 mA or less		

## How to order

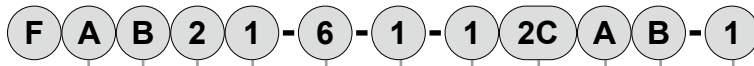

No. of ports  
(2-port valve)

Working fluid  
(Compressed air) **A** Series size

**B** Actuation

**C** Port size

**D** Orifice size

\*1

**E** Body/sealant combination

\*2

**F** Coil option

\*3

\*4

\*5

**G** Manual override

\*6

**H** Other options

Other options

[Example of model No.]

**FAB21-6-1-12CAB-1**

Model : FAB

- A** Series size : 22 mm
- B** Actuation : NC
- C** Port size : Rc1/8
- D** Orifice size :  $\phi$ 1.5
- E** Body/sealant combination

: Body - aluminum, sealant - NBR, actuation - NC

- F** Coil option : Grommet lead wire
- G** Manual override : Manual locking
- H** Other options : Mounting plate
- I** Voltage : 100 VAC50/60 Hz

### ⚠ Precautions for model No. selection

- \*1 : For FAB51 with orifice of  $\phi$ 4 mm (Item **D** 5) and  $\phi$ 5 mm (Item **D** 6), available port size is Rc3/8 (Item **C** 10) only.
- \*2 : For Item **E** 1, only NC is available. For Item **E** 0, only NO is available.
- \*3 : For FAB11 Item **F** 2G, the compact terminal box (G1/4) is used.
- \*4 : For FAB21 Item **F** 2G, 2HS, the DIN terminal box (Pg9) is used.
- \*5 : The surge suppressor is built into the coil for Item **F** 2CS and in the terminal box for 2HS and 3RS.
- \*6 : Manual override is available only for NC.
- \*7 : Other voltages may not be available. Contact CKD for details.

		Model No.							
		FAB11	FAB21	FAB31	FAB41	FAB51	FAB32	FAB42	FAB52
Code	Content								
<b>A Series size</b>									
1	18 mm	●							
2	22 mm		●						
3	28 mm			●					
4	34 mm				●			●	
5	40 mm					●			●
<b>B Actuation</b>									
1	NC	●	●	●	●	●			
2	NO						●	●	●
<b>C Port size</b>									
M5	M5	●							
6	Rc1/8		●	●			●		
8	Rc1/4			●	●		●	●	●
10	Rc3/8				●	●	●	●	●
15	Rc1/2					●			●
<b>D Orifice size</b>									
Z	$\phi$ 1	●							
1	$\phi$ 1.5	●	●						
2	$\phi$ 2		●	●			●		
3	$\phi$ 3			●	●		●	●	●
5	$\phi$ 4				●	●	●	●	●
6	$\phi$ 5			●		●	●	●	●
7	$\phi$ 7				●	●	●	●	●
8	$\phi$ 10					●			●
<b>E Body/sealant combination</b>									
	<b>Body</b>	<b>Seal</b>	<b>Actuation</b>						
1	Aluminum	NBR	NC	●	●	●	●	●	
0	Copper alloy	NBR	NO						●
<b>F Coil option</b>									
2C	Std.	Grommet lead wire		●	●	●	●	●	●
2CS	Option	Grommet lead wire with surge suppressor		●	●	●	●	●	●
2G		With DIN terminal box (Pg11)		●	●	●	●	●	●
2HS		DIN terminal box with lamp/surge suppressor (Pg11)		●	●	●	●	●	●
2CG		Conduit (CTC19)			●	●	●	●	●
2CH		Conduit (G1/2)				●	●	●	●
3T		With T type terminal box (G1/2)				●	●	●	●
3RS	T type terminal box with lamp/surge suppressor (G1/2)				●	●	●	●	
<b>G Manual override</b>									
Blank	Std.	None		●	●	●	●	●	●
A	Option	Manual locking		●	●	●	●		
N		Manual non-locking			●	●	●		
<b>H Other options</b>									
Blank	Std.	None		●	●	●	●	●	●
B	Option	Mounting plate		●	●	●	●	●	●
<b>I Voltage</b>									
1	100 VAC 50/60 Hz		●	●	●	●	●	●	●
2	200 VAC 50/60 Hz		●	●	●	●	●	●	●
3	24 VDC		●	●	●	●	●	●	●
4	12 VDC		●	●	●	●	●	●	●

Specify the desired voltage if it is not listed above.

Select from the combinations indicated with ● in the table above.

- EXA
- FWD
- HNB/G
- USB/G
- FAB/G
- FGB/G
- FVB
- FWB/G
- FHB
- FLB
- AB
- AG
- AP/AD
- APK/ADK
- DryAir
- EX-XPLNprf
- XPLNprf
- HVB/HVL
- S $\Delta$ B/NAB
- LAD/NAD
- Water-Rela
- NP/NAP/NVP
- SNP
- CHB/G
- MXB/G
- Other valves
- SWD/MWD
- DustColl
- CVE/CVSE
- CCH/CPE/D
- LifeSci
- Gas-Combust
- Auto-Water
- SpecFld
- Custom
- Ending

# FAB Series

FAB\*1 Series: NC

## Internal structure and parts list

- EXA
- FWD
- HNB/G
- USB/G
- FAB/G**
- FGB/G
- FVB
- FWB/G
- FHB
- FLB
- AB
- AG
- AP/AD
- APK/ADK
- DryAir
- EX-XPLNprf
- XPLNprf
- HVB/HVL
- SAB/NAB
- LAD/NAD
- Water-Rela
- NP/NAP/NVP
- SNP
- CHB/G
- MXB/G
- Other valves
- SWD/MWD
- DustColl
- CVE/CVSE
- CCH/CPE/D
- LifeSci
- Gas-Combus
- Auto-Water
- SpecFld
- Custom
- Ending

● FAB\*1 Series

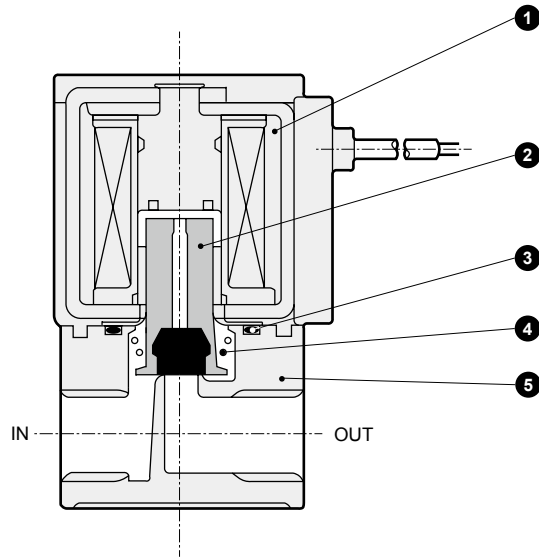

No.	Part name	Material	
1	Coil assembly	-	-
2	Plunger assembly	SUS, NBR	Stainless steel, nitrile rubber
3	O-ring	NBR	Nitrile rubber
4	Spring	SUS	Stainless steel
5	Body	ADC	Aluminum die-casting

## Dimensions



● Grommet lead wire  
FAB\*1-\*.\*.2C

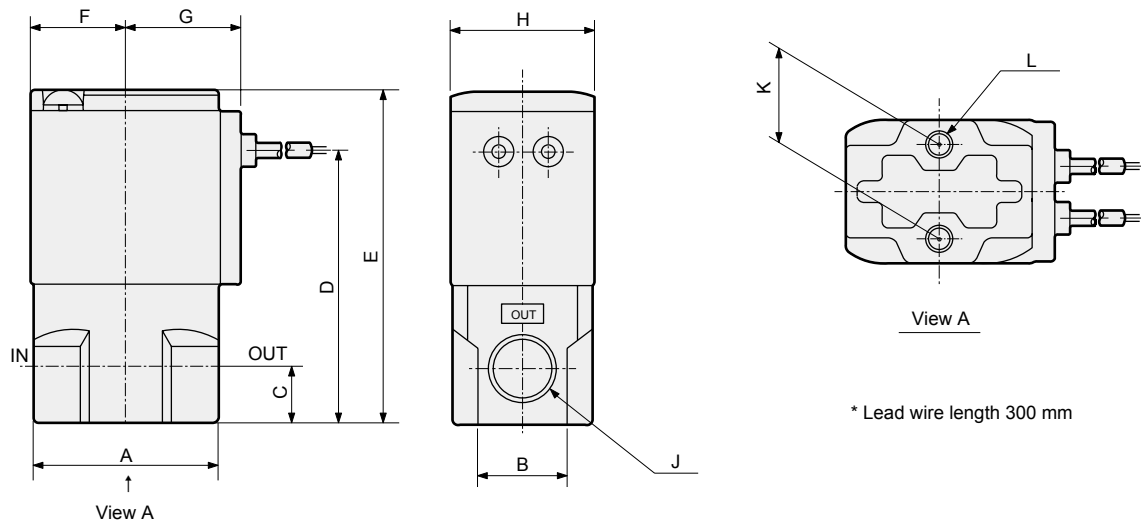

\* Lead wire length 300 mm

Model No.	A	B	C	D	E	F	G	H	J	K	L
FAB11	25	14	5	34	43.5	13	17	18	M5	10	M4 depth 5.5
FAB21	32	16	8	43	54	15.5	19.5	22	Rc1/8	15	M4 depth 6
FAB31	36	18	11	53.5	65.5	18.5	22.5	28	Rc1/8, Rc1/4	18	M5 depth 6
FAB41	40	25	12	62	76	22.5	26	34	Rc1/4, Rc3/8	18	M5 depth 7
FAB51	50	30	15	74.5	90.5	26	29.5	40	Rc3/8, Rc1/2	20	M5 depth 8

## Optional dimensions



(Refer to the dimensions of grommet lead wire on the left page for common dimensions.)

- Grommet lead wire with surge suppressor  
FAB\*1-\*.\*\*\***[2CS]**

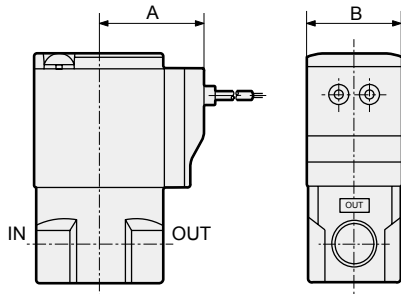

Model No.	A	B
FAB11	24.5	18
FAB21	26.5	22
FAB31	29.5	28
FAB41	34	34
FAB51	37.5	40

- DIN terminal box (with lamp/surge suppressor)  
FAB\*1-\*.\*\*\***[2G 2HS]**

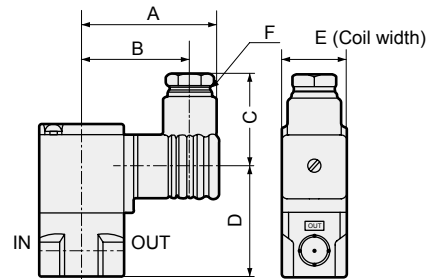

Model No.	A	B	C	D	E	F
FAB11	36	28.5	22	32	18	G1/4
FAB21	53	44	38	36.5	22	Pg 9
FAB31	58.5	47	39	47	28	Pg11
FAB41	62	50.5	39	55.5	34	Pg11
FAB51	65.5	54	39	70	40	Pg11

- Conduit (CTC19 / G1/2)  
FAB\*1-\*.\*\*\***[2CG 2CH]**

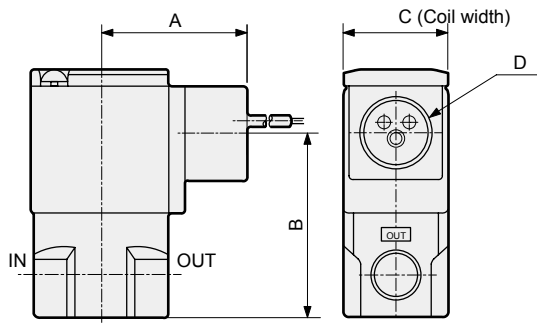

Model No.	A	B	C	D
FAB31	39	48.5	28	CTC19 G1/2
FAB41	43	57.5	34	CTC19 G1/2
FAB51	46.5	71.5	40	CTC19 G1/2

- T type terminal box (with lamp/surge suppressor) (G1/2)  
FAB\*1-\*.\*\*\***[3T 3RS]**

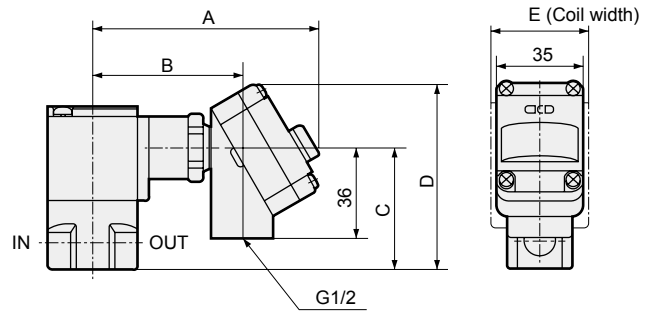

Model No.	A	B	C	D	E
FAB31	92	60.5	48.5	74.5	28
FAB41	96	64.5	57.5	83.5	34
FAB51	99.5	68	71.5	97.5	40

- Mounting plate  
FAB\*1-\*.\*\*\***[B]** Material : Steel  
Zinc plated

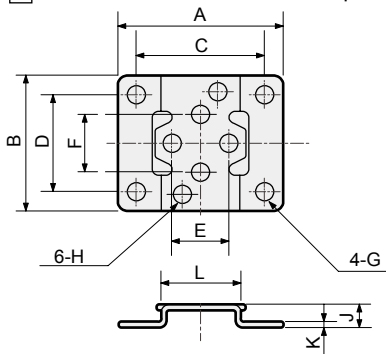

Model No.	A	B	C	D	E	F	G	H	J	K	L
FAB11	40	30	30	21	10	10	φ5	φ4.5	6	1.2	19
FAB21	40	34	30	25	15	15	φ5	φ4.5	6	1.2	20
FAB31	52	42	40	30	18	18	φ6	φ5.5	7	1.6	25
FAB41	56	48	44	36	18	18	φ6	φ5.5	7	1.6	30
FAB51	62	50	50	38	20	20	φ6	φ5.5	7	1.6	36

- Manual override locking/non-locking  
FAB\*1-\*.\*\*\***[A N]**

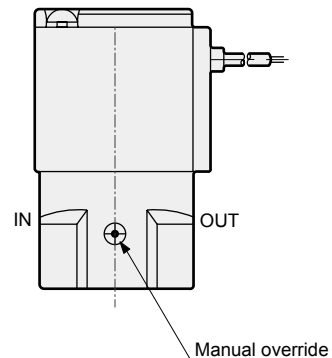

Note : Non-locking is available only for sizes 3/4/5.

EXA
FWD
HNB/G
USB/G
FAB/G
FGB/G
FVB
FWB/G
FHB
FLB
AB
AG
AP/ AD
APK/ ADK
DryAir
EX- XPLNprf
XPLNprf
HVB/ HVL
S $\nabla$ B/ NAB
LAD/ NAD
Water- Rela
NP/NAP/ NVP
SNP
CHB/G
MXB/G
Other valves
SWD/ MWD
DustCoil
CVE/ CVSE
CCH / CPE/D
LifeSci
Gas- Combus
Auto- Water
SpecFld
Custom
Ending

# FAB Series

FAB\*2 Series: NO

- EXA
- FWD
- HNB/G
- USB/G
- FAB/G**
- FGB/G
- FVB
- FWB/G
- FHB
- FLB
- AB
- AG
- AP/AD
- APK/ADK
- DryAir
- EX-XPLNprf
- XPLNprf
- HVB/HVL
- SAB/NAB
- LAD/NAD
- Water-Rela
- NP/NAP/NVP
- SNP
- CHB/G
- MXB/G
- Other valves
- SWD/MWD
- DustColl
- CVE/CVSE
- CCH/CPE/D
- LifeSci
- Gas-Combus
- Auto-Water
- SpecFld
- Custom
- Ending

## Internal structure and parts list

● FAB\*2 Series

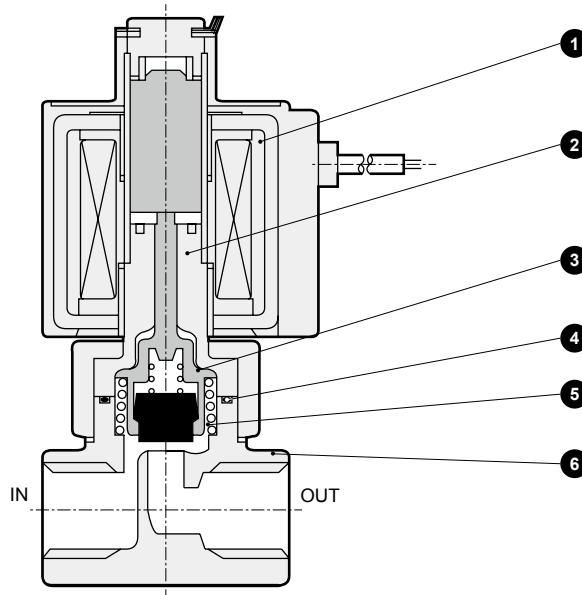

No.	Part name	Material	
1	Coil assembly	-	-
2	Core assembly	SUS, Cu	Stainless steel, copper
3	Valving element guide assembly	PPS, SUS, NBR	Polyphenylene sulfide, stainless steel, nitrile rubber
4	O-ring	NBR	Nitrile rubber
5	Spring	SUS	Stainless steel
6	Body	C3771	Copper alloy

## Dimensions



● Grommet lead wire  
FAB\*2-\*.\*2C

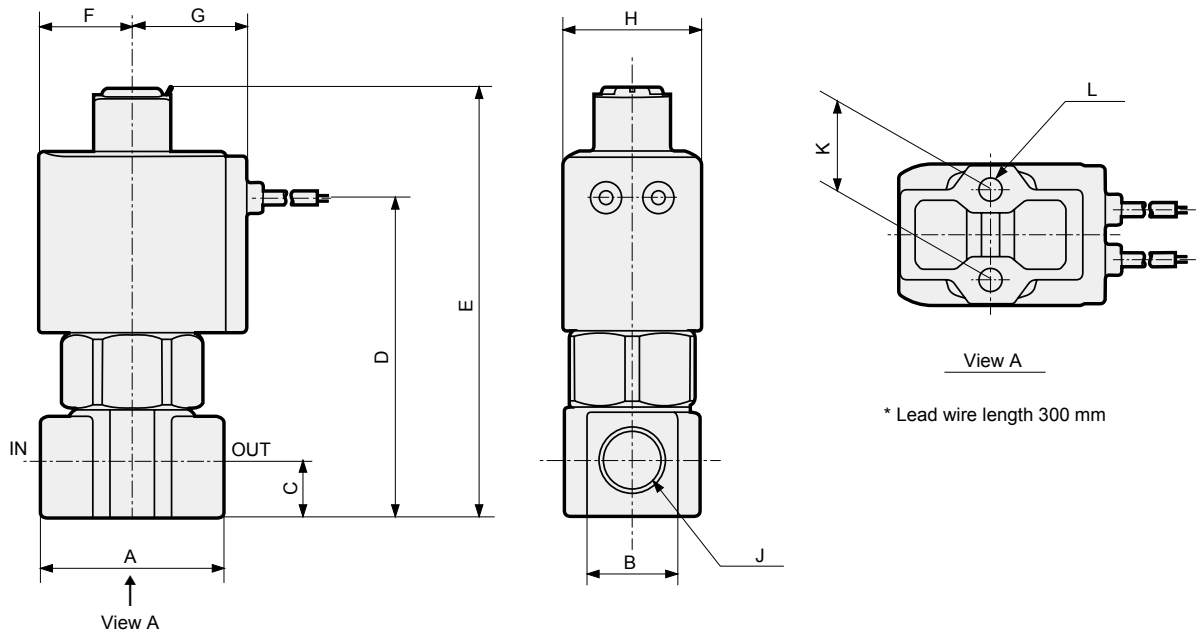

\* Lead wire length 300 mm

Model No.	A	B	C	D	E	F	G	H	J	K	L
FAB32	36	18	11	62.5	84	18.5	22.5	28	Rc1/8, Rc1/4	18	M5 depth 6
FAB42	40	21	12	71.5	96	22.5	26	34	Rc1/4, Rc3/8	18	M5 depth 8
FAB52	40	21	12	78	103.5	26	29.5	40	Rc1/4, Rc3/8	18	M5 depth 8

## Optional dimensions

(Refer to the dimensions of grommet lead wire on the left page for common dimensions.)

- Grommet lead wire with surge suppressor  
FAB\*2-\*-\*-\* [2CS]

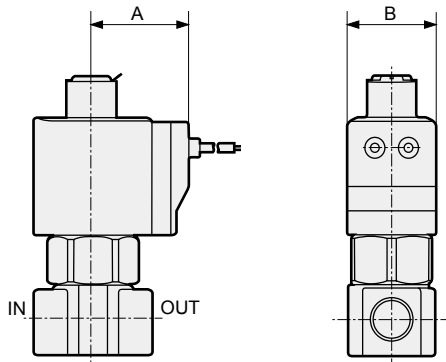

Model No.	A	B
FAB32	29.5	28
FAB42	34	34
FAB52	37.5	40

- DIN terminal box (with lamp/surge suppressor)  
FAB\*2-\*-\*-\* [2G 2HS]

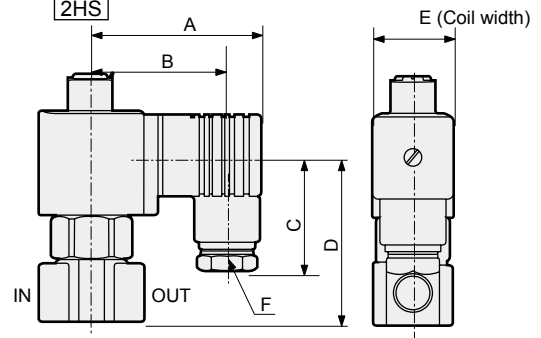

Model No.	A	B	C	D	E	F
FAB32	58.5	47	39	56.5	28	Pg11
FAB42	62	50.5	39	65	34	Pg11
FAB52	65.5	54	39	73.5	40	Pg11

- Conduit (CTC19 / G1/2)  
FAB\*2-\*-\*-\* [2CG 2CH]

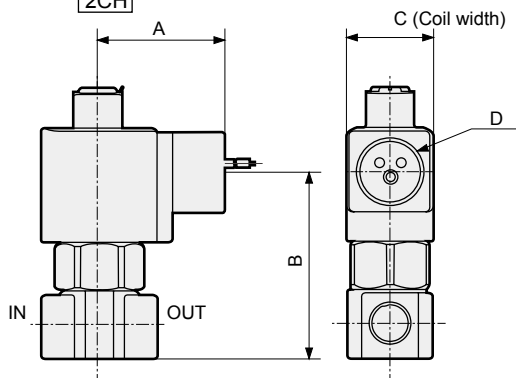

Model No.	A	B	C	D
FAB32	39	58	28	CTC19 G1/2
FAB42	43	67	34	CTC19 G1/2
FAB52	46.5	75	40	CTC19 G1/2

- T type terminal box (with lamp/surge suppressor)  
(G1/2) FAB\*2-\*-\*-\* [3T 3RS]

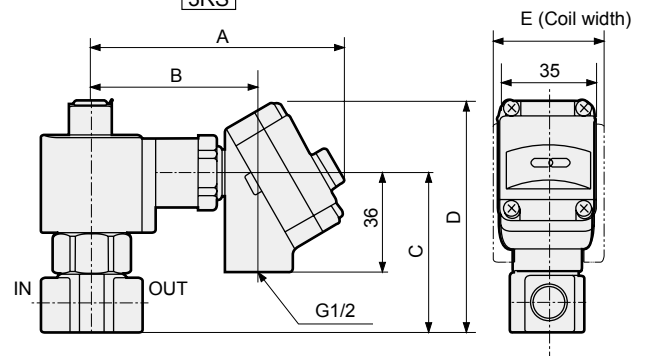

Model No.	A	B	C	D	E
FAB32	92	60.5	58	84	28
FAB42	96	64.5	67	93	34
FAB52	99.5	68	75	101	40

- Mounting plate  
FAB\*2-\*-\*-\* [B]

Material : Steel  
Zinc plated

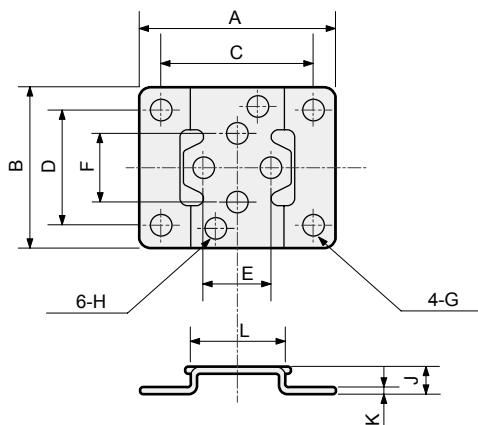

Model No.	A	B	C	D	E	F	G	H	J	K	L
FAB32	52	42	40	30	18	18	φ6	φ5.5	7	1.6	25
FAB42/52	56	48	44	36	18	18	φ6	φ5.5	7	1.6	30

- EXA
- FWD
- HNB/G
- USB/G
- FAB/G**
- FGB/G
- FVB
- FWB/G
- FHB
- FLB
- AB
- AG
- AP/  
AD
- APK/  
ADK
- DryAir
- EX-  
XPLNprf
- XPLNprf
- HVB/  
HVL
- SAB/  
NAB
- LAD/  
NAD
- Water-  
Rela
- NP/NAP/  
NVP
- SNP
- CHB/G
- MXB/G
- Other  
valves
- SWD/  
MWD
- DustColl
- CVE/  
CVSE
- CCH /  
CPE/D
- LifeSci
- Gas-  
Combus
- Auto-  
Water
- SpecFld
- Custom
- Ending

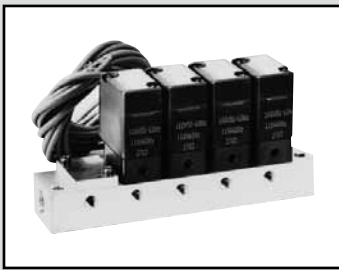

Direct acting 2-port solenoid valve for compressed air, manifold (Special purpose valve)

# GFAB Series

- NC
- Port size: M5, Rc1/8, Rc1/4, Rc3/8



Refer to the Ending for details.



## JIS symbol

- NC/common supply (port C pressurization)

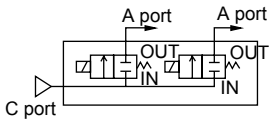

- NC/individual supply (port A pressurization)

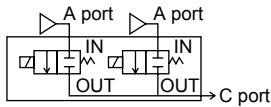

## Common specifications

Descriptions	GFAB
Working fluid	Compressed air
Working pressure differential MPa	0 (≈0 psi, 0 bar) to 1.4 (≈200 psi, 14 bar) (refer to the max. working pressure differential in the individual specifications)
Proof pressure (water pressure) MPa	2.1 (≈300 psi, 21 bar) (1.5 (≈220 psi, 15 bar) for GFAB11/GFAB21)
Fluid temperature °C	AC: -10 (14°F) to 60 (140°F), DC: -10 (14°F) to 40 (104°F) (no freezing)
Ambient temperature °C	AC: -20 (-4°F) to 40 (104°F), DC: -20 (-4°F) to 40 (104°F)
Thermal class	Class 130 (B)
Atmosphere	Place free of corrosive gas and explosive gas
Valve structure	Direct acting poppet structure
Valve seat leakage cm <sup>3</sup> /min(ANR)	0.2 or less
Mounting orientation	Unrestricted
Degree of protection	IP65 or equivalent (*1)

\*1 : The T type terminal box is IP61 or equivalent, and the GFAB11/GFAB15 compact terminal box is IP40 or equivalent.

## Individual specifications

1 MPa ≈ 145.0 psi, 1 MPa = 10 bar

Descriptions Model No.	Port size		Orifice size (mm)	Flow characteristics			Max. working press diff MPa		Max. working pressure MPa	Rated voltage	Apparent power (VA)				Power consumption (W)						
	A port	C port		C [dm <sup>3</sup> /(s·bar)]	b	AC	DC	When holding			When starting		AC 50/60 Hz	DC							
								50 Hz			60 Hz	50 Hz			60 Hz						
GFAB 11/15 -Z -1	M5	Rc1/8	1	0.15	0.54	0.7	0.7	1.0	100 VAC	7.5	5.5	20	17	4/3.4	6.5						
			1.5	0.31	0.49	0.3	0.3									3.4	2.6	5.0	4.6	2.3/1.6	3
GFAB 21/25 -1 -2	Rc1/8	Rc1/8	1.5	0.31	0.49	1.0	1.0	1.4	200 VAC	15	11	40	35	7.5/6.5	8						
			2	0.53	0.38	0.6	0.6									5.3	3.7	10	9	2.7/2	4
GFAB 31/35 -2 -3 -6	Rc1/4	Rc3/8	2	0.55	0.48	1.4	1.4	1.4	24 VDC	20	11	40	35	7.5/6.5	8						
			3	1.2	0.39	1.0	0.6									20	16	55	45	11/9.5	11.5
			5	2.1	0.27	0.3	0.15									20	16	55	45	11/9.5	11.5
GFAB 41/45 -3 -5 -7	Rc1/4	Rc3/8	3	1.2	0.39	1.4	1.4	1.4	12 VDC	20	11	40	35	7.5/6.5	8						
			4	2.1	0.34	1.0	0.9									20	16	55	45	11/9.5	11.5
			7	3.5	0.21	0.25	0.15									20	16	55	45	11/9.5	11.5
GFAB 51/55 -5 -6 -7	Rc1/4	Rc3/8	4	2.1	0.34	1.2	1.2	1.4	12 VDC	20	11	40	35	7.5/6.5	8						
			5	3.0	0.22	0.7	0.8									20	16	55	45	11/9.5	11.5
			7	4.4	0.18	0.3	0.3									20	16	55	45	11/9.5	11.5

\*1 : The voltage fluctuation range must be within ±10% of the rated voltage.

\*2 : The leakage current must be less than or equal to the values shown below.

\*3 : Effective cross-sectional area S and sonic conductance C are converted as  $S \approx 5.0 \times C$ .

\*4 : The 100 VAC (50/60 Hz) can be used with 110 VAC (60 Hz).

The 200 VAC (50/60 Hz) can be used with 220 VAC (60 Hz).

Leakage current	Voltage	100 VAC	200 VAC	24 VDC	12 VDC
	Model No.				
GFAB1	GFAB1	2 mA or less	1 mA or less	1 mA or less	2 mA or less
	GFAB2	3 mA or less	1.5 mA or less		
	GFAB3/4/5	6 mA or less	3 mA or less		

## Weight

Model No.	Actuator weight (kg)	Masking weight (kg)	Sub-plate weight (kg) (n: manifold station No.)	Formula for product weight
GFAB11 GFAB15	0.065	0.008	0.015+0.017×n	(Product weight (kg)) = 0.065 x (Actuator quantity) + 0.008 x (Masking quantity) + 0.015 + 0.017 x (Manifold station No.)
GFAB21 GFAB25	0.11	0.012	0.017+0.025×n	(Product weight (kg)) = 0.11 x (Actuator quantity) + 0.012 x (Masking quantity) + 0.017 + 0.025 x (Manifold station No.)
GFAB31 GFAB35	0.18	0.026	0.038+0.056×n	(Product weight (kg)) = 0.18 x (Actuator quantity) + 0.026 x (Masking quantity) + 0.038 + 0.056 x (Manifold station No.)
GFAB41 GFAB45	0.32	0.032	0.044+0.076×n	(Product weight (kg)) = 0.32 x (Actuator quantity) + 0.032 x (Masking quantity) + 0.044 + 0.076 x (Manifold station No.)
GFAB51 GFAB55	0.52	0.045	0.053+0.11×n	(Product weight (kg)) = 0.52 x (Actuator quantity) + 0.045 x (Masking quantity) + 0.053 + 0.11 x (Manifold station No.)

## How to order

● Manifold

**G F A B 3 1 - 2 - 7 - 1 2C N - 1**

● Manifold with masking plate

**G F A B 2 5 - 1 - X - 1 2G N - 2 - 5 2**

No. of ports  
(2-port valve)  
Working fluid  
(Compressed air)

**A** Series size

**B** Circuit configuration

**C** Orifice size

**D** Manifold station No.

\*1  
\*2

**E** Body/sealant combination

**F** Coil option

\*3  
\*4  
\*5

**G** Manual override

**H** Voltage

\*6

**I** No. of solenoid valves  
\*7

**J** Masking plate quantity

[Example of model No.]

**GFAB31-2-7-12CN-1**

Model : GFAB

- A** Series size : 28 mm
- B** Circuit configuration : NC/common supply
- C** Orifice size : φ2
- D** Manifold station No. : 7 stations
- E** Body/sealant combination: Body - PPS, sealant - NBR
- F** Coil option : Grommet lead wire
- G** Manual override : Manual non-locking
- H** Voltage : 100 VAC 50/60 Hz
- I** **J** : No masking plate

### ⚠ Precautions for model No. selection

- \*1 : Select a desired manifold station No. from 2 to 10.
- \*2 : For the type with masking plate, designate Item **D** as "X", then designate the quantities of **I** solenoid valves and **J** masking plates.
- \*3 : For GFAB11/15 Item **F** 2G, the compact terminal box (G1/4) is used.
- \*4 : For GFAB21/25 Item **F** 2G/2HS, the DIN terminal box (Pg9) is used.
- \*5 : The surge suppressor is built into the coil for Item **F** 2CS and in the terminal box for 2HS and 3RS.
- \*6 : Other voltages may not be available. Contact CKD for details.
- \*7 : Solenoid valves are arranged from the right side with the sub-plate (individual) port A facing front.
- \*8 : Orders for only the masking plate and sub-plate are also available. Contact CKD for details.

		Model No.				
		GFAB11/15	GFAB21/25	GFAB31/35	GFAB41/45	GFAB51/55
Code	Content					
<b>A Series size</b>						
1	18 mm	●				
2	22 mm		●			
3	28 mm			●		
4	34 mm				●	
5	40 mm					●
<b>B Circuit configuration</b>						
1	NC/common supply	●	●	●	●	●
5	NC/individual supply	●	●	●	●	●
<b>C Orifice size</b>						
<b>Z</b>	φ1	●				
1	φ1.5	●	●			
2	φ2		●	●		
3	φ3			●	●	
5	φ4				●	●
6	φ5				●	●
7	φ7				●	●
<b>D Manifold station No.</b>						
2	2 stations					
to	to	●	●	●	●	●
10	10 stations					
0	Actuator only	●	●	●	●	●
X	With masking plate	●	●	●	●	●
<b>E Body/sealant combination</b>						
	<b>Body</b>	<b>Seal</b>				
1	PPS	NBR	●	●	●	●
<b>F Coil option</b>						
2C	Std. Grommet lead wire	●	●	●	●	●
2CS	Grommet lead wire With surge suppressor	●	●	●	●	●
2G	With DIN terminal box (Pg11)	●	●	●	●	●
2HS	DIN terminal box with lamp/ surge suppressor (Pg11)		●	●	●	●
2CG	Conduit (CTC19)			●	●	●
2CH	Conduit (G1/2)			●	●	●
3T	With T type terminal box (G1/2)				●	●
3RS	T type terminal box with lamp surge suppressor (G1/2)				●	●
<b>G Manual override</b>						
Blank	Std. None	●	●	●	●	●
N	Option Manual non-locking	●	●	●	●	●
<b>H Voltage</b>						
1	100 VAC 50/60 Hz	●	●	●	●	●
2	200 VAC 50/60 Hz	●	●	●	●	●
3	24 VDC	●	●	●	●	●
4	12 VDC	●	●	●	●	●
Specify the desired voltage if it is not listed above.						
<b>I No. of solenoid valves</b>						
Blank	No masking plate	●	●	●	●	●
1	1 solenoid valve					
to	to	●	●	●	●	●
9	9 solenoid valves					
<b>J Masking plate quantity</b>						
Blank	No masking plate	●	●	●	●	●
1	1 masking plate					
to	to	●	●	●	●	●
9	9 masking plates					

Select from the combinations indicated with ● in the table above.

EXA  
FWD  
HNB/G  
USB/G  
FAB/G  
FGB/G  
FVB  
FWB/G  
FHB  
FLB  
AB  
AG  
AP/  
AD  
APK/  
ADK  
DryAir  
EX-  
XPLNprf  
XPLNprf  
HVB/  
HVL  
SAB/  
NAB  
LAD/  
NAD  
Water-  
Rela  
NP/NAP/  
NVP  
SNP  
CHB/G  
MXB/G  
Other  
valves  
SWD/  
MWD  
DustColl  
CVE/  
CVSE  
CCH /  
CPE/D  
LifeSci  
Gas-  
Combus  
Auto-  
Water  
SpecFld  
Custom  
Ending



## Internal structure and parts list

- EXA
- FWD
- HNB/G
- USB/G
- FAB/G**
- FGB/G
- FVB
- FWB/G
- FHB
- FLB
- AB
- AG
- AP/  
AD
- APK/  
ADK
- DryAir
- EX-  
XPLNprf
- XPLNprf
- HVB/  
HVL
- S $\nabla$ B/  
NAB
- LAD/  
NAD
- Water-  
Rela
- NP/NAP/  
NVP
- SNP
- CHB/G
- MXB/G
- Other  
valves
- SWD/  
MWD
- DustColl
- CVE/  
CVSE
- CCH /  
CPE/D
- LifeSci
- Gas-  
Combus
- Auto-  
Water
- SpecFld
- Custom
- Ending

● GFAB actuator

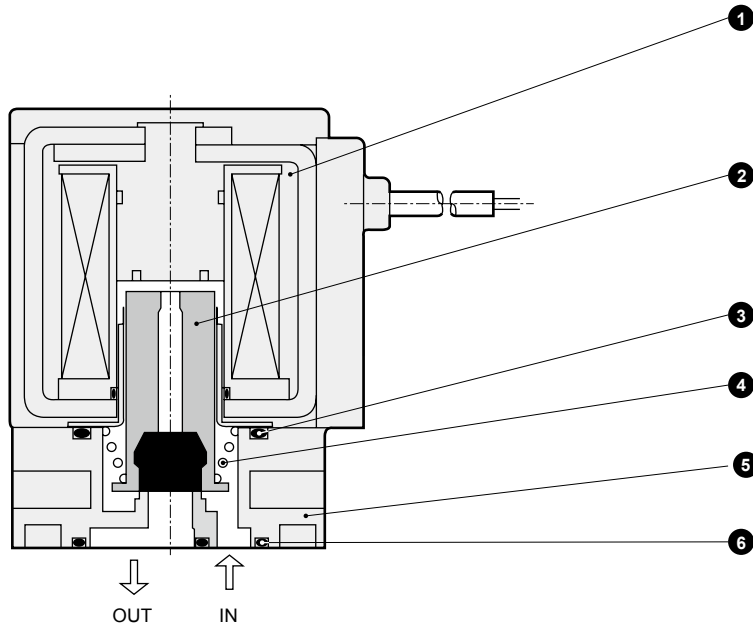

● GFAB manifold

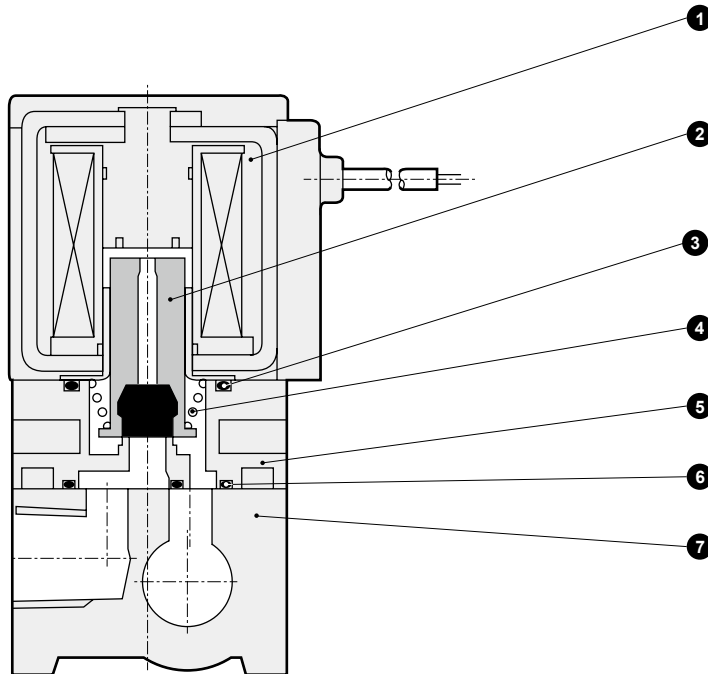

No.	Part name	Material	No.	Part name	Material
1	Coil assembly	-	5	Body	PPS Polyphenylene sulfide
2	Plunger assembly	SUS, NBR Stainless steel, nitrile rubber	6	Gasket	NBR Nitrile rubber
3	O-ring	NBR Nitrile rubber	7	Sub-plate	A6063 Aluminum
4	Spring	SUS Stainless steel			

\* 4 body mounting screws and 2 O-rings are attached to the actuator only.

## Dimensions: Manifold



- Grommet lead wire  
GFAB\*\*-\*-12C

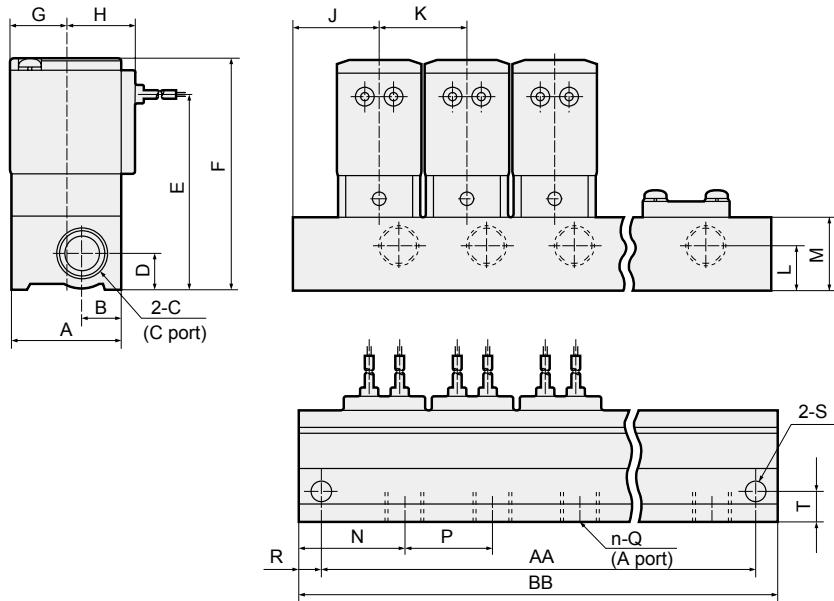

Lead wire length 300 mm

Model No.	Station No. Code	2	3	4	5	6	7	8	9	10
GFAB1	AA	48	68	88	108	128	148	168	188	208
	BB	58	78	98	118	138	158	178	198	218
GFAB2	AA	58	84	110	136	162	188	214	240	266
	BB	68	94	120	146	172	198	224	250	276
GFAB3	AA	74	106	138	170	202	234	266	298	330
	BB	88	120	152	184	216	248	280	312	344
GFAB4	AA	86	124	162	200	238	276	314	352	390
	BB	100	138	176	214	252	290	328	366	404
GFAB5	AA	100	146	192	238	284	330	376	422	468
	BB	114	160	206	252	298	344	390	436	482

Model No.	A	B	C	D	E	F	G	H	J	K	L	M	N	P	Q	R	S	T
GFAB1	25	10	Rc1/8	8	44.5	54	13	17	19	20	11	16	21.5	20	M5	5	φ4.5	6.5
GFAB2	30	12	Rc1/8	8	49	60	15.5	19.5	21	26	8	16	25	26	Rc1/8	5	φ4.5	9
GFAB3	36	13	Rc3/8	12	64	76	18.5	22.5	28	32	15	24	34.5	32	Rc1/4	7	φ6.5	10
GFAB4	43	18	Rc3/8	12	71	85	22.5	26	31	38	15	24	31	38	Rc1/4	7	φ6.5	11.5
GFAB5	50	20	Rc3/8	12	79	95	26	29.5	34	46	12	24	34	46	Rc1/4	7	φ6.5	14

## Dimensions: Actuator



- Grommet lead wire  
GFAB\*\*-\*-0-12C

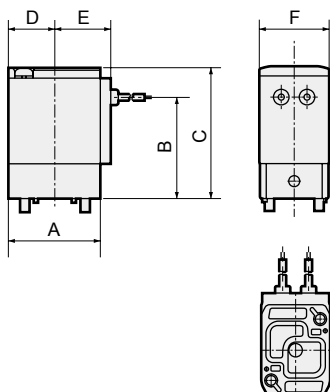

Model No.	A	B	C	D	E	F
GFAB1	25	28.5	38	13	17	18
GFAB2	30	33	44	15.5	19.5	22
GFAB3	36	40	52	18.5	22.5	28
GFAB4	43	47	61	22.5	26	34
GFAB5	50	55	71	26	29.5	40

\* Lead wire length 300 mm

EXA
FWD
HNB/G
USB/G
FAB/G
FGB/G
FVB
FWB/G
FHB
FLB
AB
AG
AP/ AD
APK/ ADK
DryAir
EX- XPLNprf
XPLNprf
HVB/ HVL
S◇B/ NAB
LAD/ NAD
Water- Rela
NP/NAP/ NVP
SNP
CHB/G
MXB/G
Other valves
SWD/ MWD
DustColl
CVE/ CVSE
CCH / CPE/D
LifeSci
Gas- Combus
Auto- Water
SpecFld
Custom
Ending

## Actuator installation dimensions

- EXA
- FWD
- HNB/G
- USB/G
- FAB/G**
- FGB/G
- FVB
- FWB/G
- FHB
- FLB
- AB
- AG
- AP/AD
- APK/ADK
- DryAir
- EX-XPLNprf
- XPLNprf
- HVB/HVL
- SAB/NAB
- LAD/NAD
- Water-Rela
- NPN/NP/NVP
- SNP
- CHB/G
- MXB/G
- Other valves
- SWD/MWD
- DustColl
- CVE/CVSE
- CCH/CPE/D
- LifeSci
- Gas-Combus
- Auto-Water
- SpecFld
- Custom
- Ending

### ● GFAB1\*/2\*/3\*

Machining drawing when using 2 actuators.

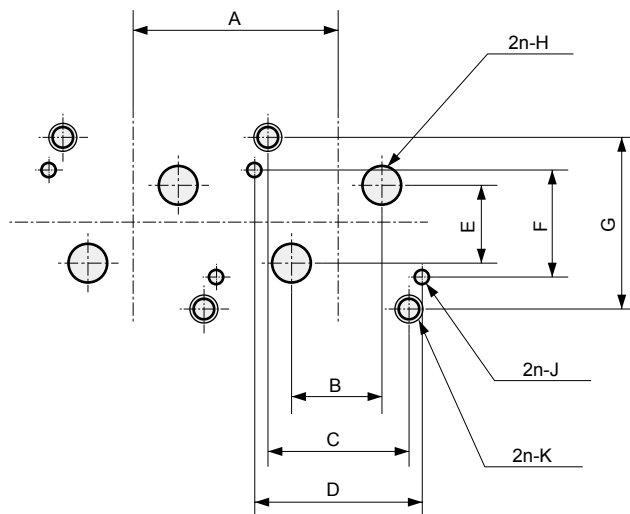

Model No.	A	B	C	D	E	F	G	H	J	K
GFAB1	20 or more	5±0.15	12.4±0.1	14.4±0.1	10±0.15	11.2±0.1	17±0.1	φ3	φ1.6 <sup>+0.1</sup> <sub>0</sub> depth 2.5±0.5	M2.5 effective thread depth 5.5 or more
GFAB2	26 or more	8±0.15	15.5±0.1	18.4±0.1	10±0.15	12.4±0.1	19.4±0.1	φ3.5	φ1.6 <sup>+0.1</sup> <sub>0</sub> depth 2.5±0.5	M3 effective thread depth 6 or more
GFAB3	32 or more	13±0.15	20±0.1	23.6±0.1	11.4±0.15	15±0.1	24.2±0.1	φ5.5	φ2.1 <sup>+0.1</sup> <sub>0</sub> depth 2.5±0.5	M4 effective thread depth of 6 or more

### ● GFAB4\*/5\*

Machining drawing when using 2 actuators.

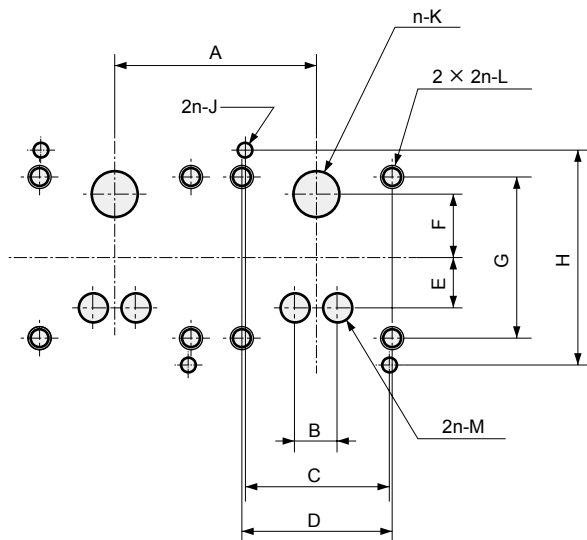

Model No.	A	B	C	D	E	F	G	H	J	K	L	M
GFAB4	38 or more	6±0.2	25±0.1	26±0.1	8.5±0.2	11±0.2	28±0.1	37±0.1	φ2.6 <sup>+0.1</sup> <sub>0</sub> depth 2.5±0.5	φ8	M4 effective thread depth 9 or more	φ5
GFAB5	46 or more	8±0.2	30±0.1	30±0.1	11.5±0.2	14.5±0.2	33±0.1	43±0.1	φ2.6 <sup>+0.1</sup> <sub>0</sub> depth 2.5±0.5	φ11	M5 effective thread depth 8 or more	φ7

## Optional dimensions

(Refer to the grommet lead wire actuator dimensions on page 61 for common dimensions.)

- Grommet lead wire with surge suppressor  
GFAB\*\*-\*-1 **2CS**

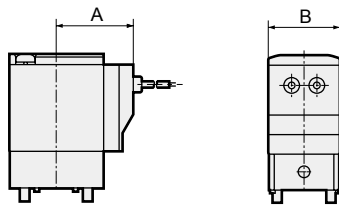

Model No.	A	B
GFAB1	24.5	18
GFAB2	26.5	22
GFAB3	29.5	28
GFAB4	34	34
GFAB5	37.5	40

- Conduit (CTC19 / G1/2)  
GFAB\*\*-\*-1 **2CG**  
**2CH**

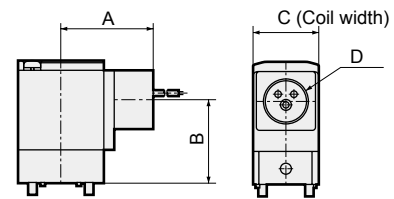

Model No.	A	B	C	D
GFAB3	39	35	28	CTC19 G1/2
GFAB4	43	42.5	34	CTC19 G1/2
GFAB5	46.5	52	40	CTC19 G1/2

- DIN terminal box (with lamp/surge suppressor)  
GFAB\*\*-\*-1 **2G**  
**2HS**

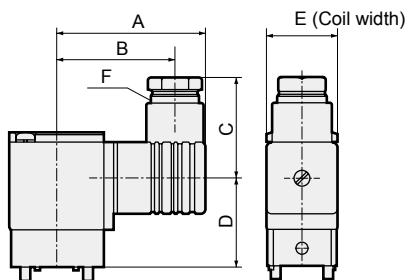

Model No.	A	B	C	D	E	F
GFAB1	36	28.5	22	26.5	18	G1/4
GFAB2	53	44	38	26.5	22	Pg9
GFAB3	58.5	47	39	33.5	28	Pg11
GFAB4	62	50.5	39	40.5	34	Pg11
GFAB5	65.5	54	39	50.5	40	Pg11

- T type terminal box (with lamp/surge suppressor) (G1/2)  
GFAB\*\*-\*-1 **3T**  
**3RS**

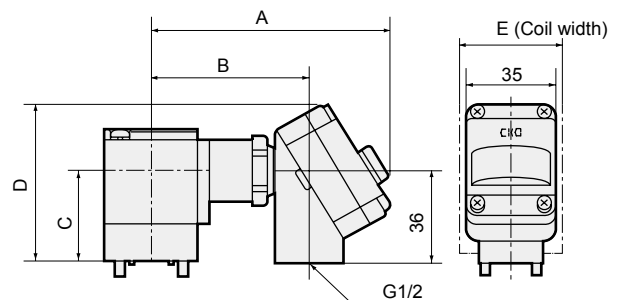

Model No.	A	B	C	D	E
GFAB4	96	64.5	42.5	68.5	34
GFAB5	99.5	68	52	78	40

- Manual override (non-locking)  
GFAB\*\*-\*-1 **N**

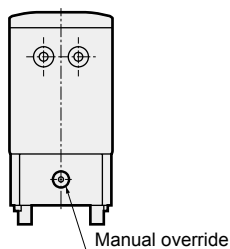

Position of manual override

- Common supply : Opposite side to port A
- Individual supply : Port A side

EXA
FWD
HNB/G
USB/G
FAB/G
FGB/G
FVB
FWB/G
FHB
FLB
AB
AG
AP/ AD
APK/ ADK
DryAir
EX- XPLNprf
XPLNprf
HVB/ HVL
S/B/ NAB
LAD/ NAD
Water- Rela
NP/NAP/ NVP
SNP
CHB/G
MXB/G
Other valves
SWD/ MWD
DustCoil
CVE/ CVSE
CCH / CPE/D
LifeSci
Gas- Combus
Auto- Water
SpecFld
Custom
Ending



Direct acting 3-port solenoid valve for compressed air, single unit  
(Special purpose valve)

# FAG Series

- Universal, NC pressurization
- Port size: M5, Rc1/8, Rc1/4, Rc3/8

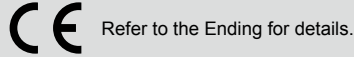

- EXA
- FWD
- HNB/G
- USB/G
- FAB/G
- FGB/G
- FVB
- FWB/G
- FHB
- FLB
- AB
- AG
- AP/AD
- APK/ADK
- DryAir
- EX-XPLNprf
- XPLNprf
- HVB/HVL
- SAB/NAB
- LAD/NAD
- Water-Rela
- NP/NAP/NVP
- SNP
- CHB/G
- MXB/G
- Other valves
- SWD/MWD
- DustColl
- CVE/CVSE
- CCH/CPE/D
- LifeSci
- Gas-Combust
- Auto-Water
- SpecFld
- Custom
- Ending

## JIS symbol

- Universal

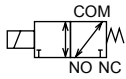

- NC pressurization

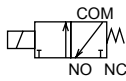

## Common specifications

Descriptions	FAG
Working fluid	Compressed air
Working pressure differential MPa	0 (≈0 psi, 0 bar) to 1.4 (≈200 psi, 14 bar) (refer to the max. working pressure differential in the individual specifications)
Proof pressure (water pressure) MPa	2.1 (≈300 psi, 21 bar) (1.5 (≈220 psi, 15 bar) for FAG11/FAG21)
Fluid temperature °C	AC: -10 (14°F) to 60 (140°F), DC: -10 (14°F) to 40 (104°F) (no freezing)
Ambient temperature °C	AC: -20 (-4°F) to 60 (140°F), DC: -20 (-4°F) to 40 (104°F)
Thermal class	Class 130 (B)
Atmosphere	Place free of corrosive gas and explosive gas
Valve structure	Direct acting poppet structure
Valve seat leakage cm <sup>3</sup> /min(ANR)	0.2 or less
Mounting orientation	Unrestricted
Degree of protection	IP65 or equivalent (*1)

\*1 : The T type terminal box is IP61 or equivalent, and the FAG11 compact terminal box is IP40 or equivalent.

## Individual specifications

1 MPa ≈ 145.0 psi, 1 MPa = 10 bar

Descriptions	Port size	Orifice size (mm)	Flow characteristics		Max. working pressure differential MPa	Max. working pressure MPa	Rated voltage	Apparent power (VA)				Power consumption (W)		Weight (kg)
			C(dm <sup>3</sup> /(s·bar))	b				When holding		When starting		AC	DC	
Model No.							50 Hz	60 Hz	50 Hz	60 Hz	50 Hz/60 Hz	DC		
<b>● Universal</b>														
FAG11- M5 -Y	M5	0.8	0.08	0.61	0.7	1.0	100 VAC 50/60 Hz	3.4	2.6	5	4.6	2.3/1.6	3	0.09
- 0		1.5	0.28	0.40	0.2			5.3	3.7	10	9	2.7/2	4	0.14
FAG21 - 6 -Z	Rc1/8	1	0.13	0.58	0.7	1.4	200 VAC 50/60 Hz	7.5	5.5	20	17	4/3.4	6.5	0.23
- 1		2	0.52	0.54	0.15									
FAG31 - <sup>6</sup> / <sub>8</sub> -0	Rc1/8	1.5	0.32	0.58	0.7	1.4	24 VDC 12 VDC	15	11	40	35	7.5/6.5	8	0.43
- 1	Rc1/4	2	0.55	0.48	0.4									
- 4	Rc3/8	3	1.2	0.57	0.2	1.4	24 VDC 12 VDC	15	11	40	35	7.5/6.5	8	0.43
FAG41 - <sup>8</sup> / <sub>10</sub> -1	Rc1/4	2	0.55	0.48	0.7									
- 4	Rc3/8	3	1.2	0.57	0.3	1.4	24 VDC 12 VDC	15	11	40	35	7.5/6.5	8	0.43
- 8	Rc3/8	4	2.1	0.48	0.15									
FAG51 - <sup>8</sup> / <sub>10</sub> -1	Rc1/4	2	0.55	0.48	1.2(0.6)	1.4	24 VDC 12 VDC	15	11	40	35	7.5/6.5	8	0.63
- 4	Rc3/8	3	1.2	0.57	0.6(0.3)									
- 8	Rc3/8	4	2.1	0.48	0.3(0.15)	1.4	24 VDC 12 VDC	15	11	40	35	7.5/6.5	8	0.43
FAG33 - <sup>6</sup> / <sub>8</sub> -0	Rc1/8	1.5	0.32	0.58	1.0									
- 1	Rc1/4	2	0.55	0.48	0.7	1.4	24 VDC 12 VDC	15	11	40	35	7.5/6.5	8	0.43
- 4	Rc1/4	3	1.2	0.57	0.3									
FAG43 - <sup>8</sup> / <sub>10</sub> -1	Rc1/4	2	0.55	0.48	1.2	1.4	24 VDC 12 VDC	15	11	40	35	7.5/6.5	8	0.43
- 4	Rc3/8	3	1.2	0.57	0.6									
- 8	Rc3/8	4	2.1	0.48	0.3	1.4	24 VDC 12 VDC	15	11	40	35	7.5/6.5	8	0.43
- 8	Rc3/8	4	2.1	0.48	0.3									

\*1 : The voltage fluctuation range must be within ±10% of the rated voltage.

\*2 : For FAG51, the max. working pressure differential when NO pressurized is shown in parentheses.

\*3 : The leakage current must be less than or equal to the values shown on the right.

\*4 : Effective cross-sectional area S and sonic conductance C are converted as  $S \approx 5.0 \times C$ .

\*5 : The 100 VAC (50/60 Hz) can be used with 110 VAC (60 Hz).  
The 200 VAC (50/60 Hz) can be used with 220 VAC (60 Hz).

Leakage current	Voltage				
	Model No.	100 VAC	200 VAC	24 VDC	12 VDC
	FAG1	2 mA or less	1 mA or less	1 mA or less	2 mA or less
	FAG2	3 mA or less	1.5 mA or less		
	FAG3/4/5	6 mA or less	3 mA or less		

## How to order

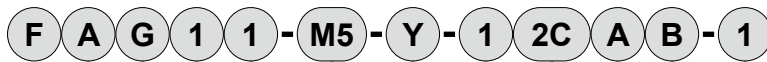

No. of ports  
(3-port valve)

Working fluid  
(Compressed air)

**A Series size**

--	--	--	--	--	--

**B Actuation**

--	--	--	--	--	--

**C Port size**

--	--	--	--	--	--

**D Orifice size**

--	--	--	--	--	--

**E Body/sealant combination**

--	--	--	--	--	--

**F Coil option**

--	--	--	--	--	--

**G Manual override**

--	--	--	--	--	--

**H Other options**

--	--	--	--	--	--

**I Voltage**

--	--	--	--	--	--

		Model No.				
		FAG11	FAG21	FAG31/33	FAG41/43	FAG51
Code	Content					
<b>A Series size</b>						
1	18 mm	●				
2	22 mm		●			
3	28 mm			●		
4	34 mm				●	
5	40 mm					●
<b>B Actuation</b>						
1	Universal	●	●	●	●	●
3	NC pressurization			●	●	
<b>C Port size</b>						
M5	M5	●				
6	Rc1/8		●	●		
8	Rc1/4			●	●	
10	Rc3/8				●	●
<b>D Orifice size</b>						
Y	φ0.8	●				
Z	φ1		●			
0	φ1.5	●				
1	φ2		●			
4	φ3			●	●	●
8	φ4				●	●
<b>E Body/sealant combination</b>						
	<b>Body</b>	<b>Seal</b>				
1	Aluminum	NBR	●	●	●	●
<b>F Coil option</b>						
2C	Grommet lead wire	●	●	●	●	●
2CS	Grommet lead wire with surge suppressor	●	●	●	●	●
2G	With DIN terminal box (Pg11)	●	●	●	●	●
2HS	DIN terminal box with lamp/surge suppressor (Pg11)		●	●	●	●
2CG	Conduit (CTC19)			●	●	●
2CH	Conduit (G1/2)			●	●	●
3T	With T type terminal box (G1/2)			●	●	●
3RS	T type terminal box with lamp/surge suppressor (G1/2)			●	●	●
<b>G Manual override</b>						
Blank	Std.	None	●	●	●	●
A	Option	Manual locking	●	●	●	●
N	Option	Manual non-locking			●	●
<b>H Other options</b>						
Blank	Std.	None	●	●	●	●
B	Option	Mounting plate	●	●	●	●
<b>I Voltage</b>						
1	100 VAC 50/60 Hz	●	●	●	●	●
2	200 VAC 50/60 Hz	●	●	●	●	●
3	24 VDC	●	●	●	●	●
4	12 VDC	●	●	●	●	●
Specify the desired voltage if it is not listed above.						

[Example of model No.]

### FAG11-M5-Y-12CAB-1

Model : FAG

- A** Series size : 18 mm
- B** Actuation : Universal
- C** Port size : M5
- D** Orifice size : φ0.8
- E** Body/sealant combination : Body - aluminum, sealant - NBR
- F** Coil option : Grommet lead wire
- G** Manual override : Manual locking
- H** Other options : Mounting plate
- I** Voltage : 100 VAC 50/60 Hz

### ⚠ Precautions for model No. selection

- \*1 : For FAG11 Item **F** 2G, the compact terminal box (G1/4) is used.
- \*2 : For FAG21 Item **F** 2G/2HS, the DIN terminal box (Pg9) is used.
- \*3 : The surge suppressor is built into the coil for Item **F** 2CS and in the terminal box for 2HS and 3RS.
- \*4 : Other voltages may not be available. Contact CKD for details.

Select from the combinations indicated with ● in the table above.

- EXA
- FWD
- HNB/G
- USB/G
- FAB/G
- FGB/G
- FVB
- FWB/G
- FHB
- FLB
- AB
- AG
- AP/AD
- APK/ADK
- DryAir
- EX-XPLNprf
- XPLNprf
- HVB/HVL
- SAB/NAB
- LAD/NAD
- Water-Rela
- NP/NAP/NVP
- SNP
- CHB/G
- MXB/G
- Other valves
- SWD/MWD
- DustColl
- CVE/CVSE
- CCH/CPE/D
- LifeSci
- Gas-Combus
- Auto-Water
- SpecFld
- Custom
- Ending

EXA  
FWD  
HNB/G  
USB/G  
FAB/G  
FGB/G  
FVB  
FWB/G  
FHB  
FLB  
AB  
AG  
AP/  
AD  
APK/  
ADK  
DryAir  
EX-  
XPLNprf  
XPLNprf  
HVB/  
HVL  
SAB/  
NAB  
LAD/  
NAD  
Water-  
Rela  
NP/NAP/  
NVP  
SNP  
CHB/G  
MXB/G  
Other  
valves  
SWD/  
MWD  
DustColl  
CVE/  
CVSE  
CCH /  
CPE/D  
LifeSci  
Gas-  
Combust  
Auto-  
Water  
SpecFld  
Custom  
Ending

## Internal structure and parts list

● FAG\*1/\*3 Series

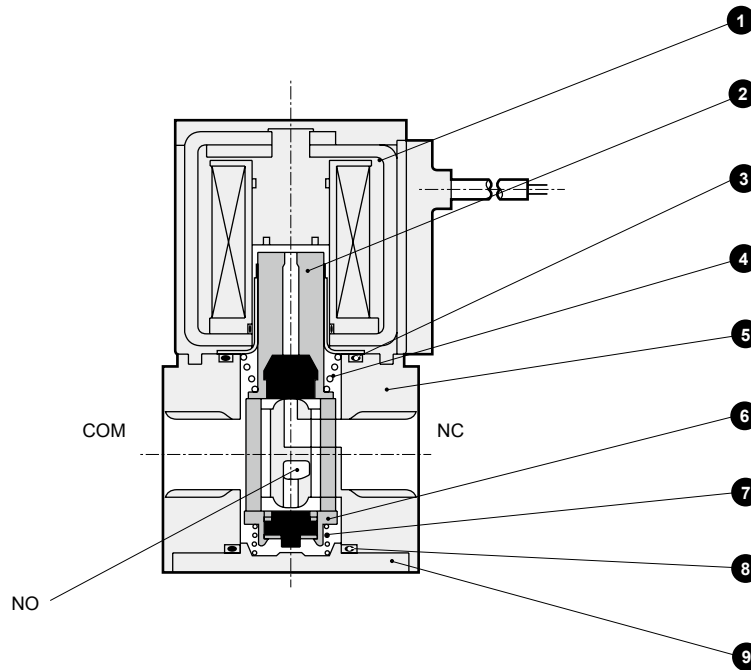

No.	Part name	Material	No.	Part name	Material
1	Coil assembly	-	6	Valving element guide assembly	PPS, SUS, NBR ; Polyphenylene sulfide, stainless steel, nitrile rubber
2	Plunger assembly	SUS, NBR ; Stainless steel, nitrile rubber	7	Spring	SUS ; Stainless steel
3	O-ring	NBR ; Nitrile rubber	8	O-ring	NBR ; Nitrile rubber
4	Spring	SUS ; Stainless steel	9	Cover	ADC ; Aluminum die-casting
5	Body	ADC ; Aluminum die-casting			

## Dimensions



● Grommet lead wire  
FAG\*\*-\*-\*12C

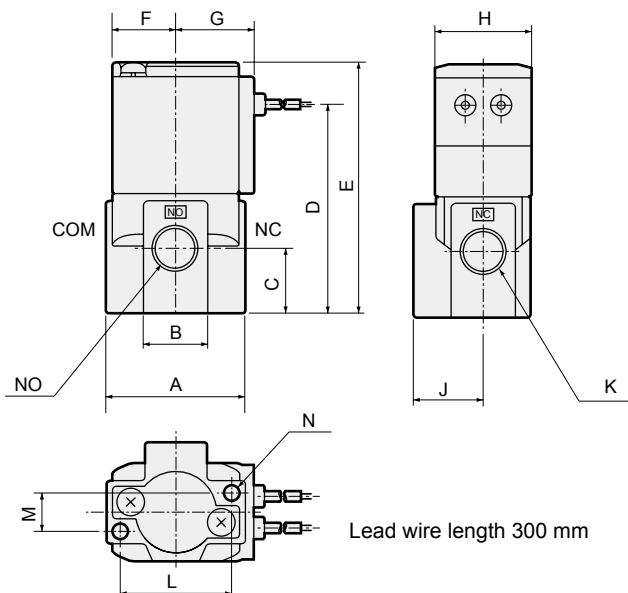

Model No.	A	B	C	D	E	F	G	H	J	K	L	M	N
FAG1	28	14	13.5	42	51.5	13	17	18	12	M5×0.8	21	7	M4 depth 5.5
FAG2	32	16	16.5	51	62	15.5	19.5	22	16	Rc1/8	25	8	M4 depth 6
FAG3	40	18	18.5	60.5	72.5	18.5	22.5	28	20	Rc1/8 Rc1/4	32	11	M5 depth 8
FAG4	45	25	25	74.5	88.5	22.5	26	34	21	Rc1/4 Rc3/8	35	15	M5 depth 8
FAG5	50	25	25	81	97	26	29.5	40	21	Rc1/4 Rc3/8	35	15	M5 depth 8

## Optional dimensions



(Refer to the dimensions of grommet lead wire on the left page for common dimensions.)

- Grommet lead wire with surge suppressor  
FAG\*\*-\*-1 **2CS**

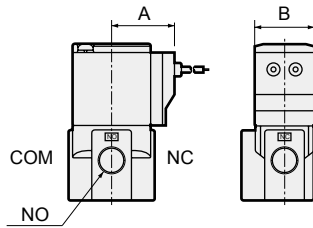

Model No.	A	B
FAG1	24.5	18
FAG2	26.5	22
FAG3	29.5	28
FAG4	34	34
FAG5	37.5	40

- DIN terminal box (with lamp/surge suppressor)  
FAG\*\*-\*-1 **2G**  
**2HS**

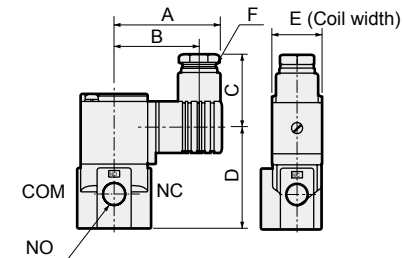

Model No.	A	B	C	D	E	F
FAG1	36	28.5	22	40	18	G1/4
FAG2	53	44	38	44.5	22	Pg9
FAG3	58.5	47	39	54	28	Pg11
FAG4	62	50.5	39	68	34	Pg11
FAG5	65.5	54	39	76.5	40	Pg11

- Conduit (CTC19 / G1/2)  
FAG\*\*-\*-1 **2CG**  
**2CH**

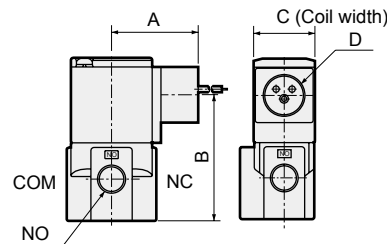

Model No.	A	B	C	D
FAG3	39	55.5	28	CTC19 G1/2
FAG4	43	70	34	CTC19 G1/2
FAG5	46.5	78	40	CTC19 G1/2

- T type terminal box (with lamp/surge suppressor) (G1/2)  
FAG\*\*-\*-1 **3T**  
**3RS**

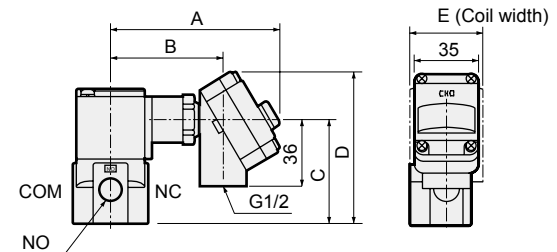

Model No.	A	B	C	D	E
FAG3	92	60.5	55.5	81.5	28
FAG4	96	64.5	70	96	34
FAG5	99.5	68	78	104	40

- Mounting plate  
FAG\*\*-\*-1\*\***B**

Material : Steel  
Zinc plated

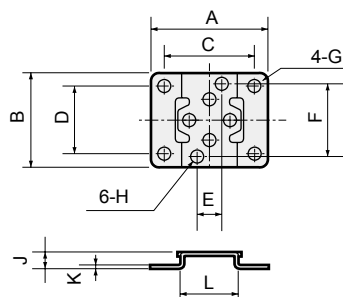

Model No.	A	B	C	D	E	F	G	H	J	K	L
FAG1	40	30	30	21	7	21	φ5	φ4.5	6	1.2	19
FAG2	40	34	30	25	8	25	φ5	φ4.5	6	1.2	20
FAG3	52	42	40	30	11	32	φ6	φ5.5	7	1.6	25
FAG4	56	48	44	36	15	35	φ6	φ5.5	7	1.6	30
FAG5	62	50	50	38	15	35	φ6	φ5.5	7	1.6	36

- Manual override (locking/non-locking)  
FAG\*\*-\*-1\***A**  
**N**

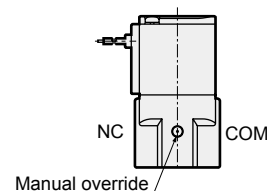

Note: Non-locking is available only for sizes 3/4/5.

EXA
FWD
HNB/G
USB/G
<b>FAB/G</b>
FGB/G
FVB
FWB/G
FHB
FLB
AB
AG
AP/ AD
APK/ ADK
DryAir
EX- XPLNprf
XPLNprf
HVB/ HVL
S◇B/ NAB
LAD/ NAD
Water- Rela
NP/NAP/ NVP
SNP
CHB/G
MXB/G
Other valves
SWD/ MWD
DustColl
CVE/ CVSE
CCH / CPE/D
LifeSci
Gas- Combus
Auto- Water
SpecFld
Custom
Ending





Direct acting 3-port solenoid valve for compressed air, manifold (Special purpose valve)

# GFAG Series

- Universal
- Port size: M5, Rc1/8, Rc1/4



Refer to the Ending for details.



EXA

FWD

HNB/G

USB/G

FAB/G

FGB/G

FVB

FWB/G

FHB

FLB

AB

AG

AP/AD

APK/ADK

DryAir

EX-XPLNprf

XPLNprf

HVB/HVL

SAB/NAB

LAD/NAD

Water-Rela

NP/NAP/NVP

SNP

CHB/G

MXB/G

Other valves

SWD/MWD

DustColl

CVE/CVSE

CCH/CPE/D

LifeSci

Gas-Combus

Auto-Water

SpecFld

Custom

Ending

## JIS symbol

- Common supply/common exhaust

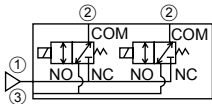

## Common specifications

Descriptions	GFAG
Working fluid	Compressed air
Working pressure differential MPa	0 (≈0 psi, 0 bar) to 1.2 (≈170 psi, 12 bar) (refer to the max. working pressure differential in the individual specifications)
Proof pressure (water pressure) MPa	1.8 (≈260 psi, 18 bar) (1.5 (≈220 psi, 15 bar) for GFAG11/GFAG21/GFAG31)
Fluid temperature °C	AC: -10 (14°F) to 60 (140°F), DC: -10 (14°F) to 40 (104°F) (no freezing)
Ambient temperature °C	AC: -20 (-4°F) to 40 (104°F), DC: -20 (-4°F) to 40 (104°F)
Thermal class	Class 130 (B)
Atmosphere	Place free of corrosive gas and explosive gas
Valve structure	Direct acting poppet structure
Valve seat leakage cm <sup>3</sup> /min(ANR)	0.2 or less
Mounting orientation	Unrestricted
Degree of protection	IP65 or equivalent (*1)

\*1 : The T type terminal box is IP61 or equivalent, and the GFAG11 compact terminal box is IP40 or equivalent.

## Individual specifications

1 MPa ≈ 145.0 psi, 1 MPa = 10 bar

Descriptions Model No.	Port size		Orifice size (mm)	Flow characteristics		Max. working pressure differential MPa	Max. working pressure MPa	Rated voltage	Apparent power (VA)				Power consumption (W)					
	2-port (Ind)	1. 3-port (common)		C [dm <sup>3</sup> /(s·bar)]	b				When holding	When starting	AC		DC					
									50 Hz	60 Hz	50 Hz	60 Hz	50/60 Hz					
GFAG11 -Y -0	M5	Rc1/8	0.8	0.08	0.55	0.7	1.0	100 VAC 50/60 Hz	3.4	2.6	5	4.6	2.3/1.6	3				
			1.5	0.25	0.29				0.2	5.3	3.7	10			9	2.7/2	4	
GFAG21 -Z -1	Rc1/8	Rc1/8	1	0.12	0.44	0.7			100 VAC 50/60 Hz	7.5	5.5	20	17	4/3.4	6.5			
			2	0.42	0.19					0.15	7.5	5.5	20			17	4/3.4	6.5
GFAG31 -0 -1 -4	Rc1/4	Rc1/4	1.5	0.28	0.46	0.7				200 VAC 50/60 Hz	15	11	40	35	7.5/6.5	8		
			2	0.49	0.36						0.4	20	17	4/3.4			6.5	
			3	0.90	0.20			0.2			20	17	4/3.4	6.5				
GFAG41 -1 -4 -8	Rc1/4	Rc1/4	2	0.50	0.31	0.7		24 VDC 12 VDC			15	11	40	35	7.5/6.5	8		
			3	1.1	0.20				0.3		15	11	40	35			7.5/6.5	8
			4	1.6	0.14				0.15		15	11	40	35			7.5/6.5	8
GFAG51 -1 -4 -8	Rc1/4	Rc1/4	2	0.50	0.31	1.2(0.6)	1.2		24 VDC 12 VDC	20	16	55	45	11/9.5	11.5			
			3	1.1	0.20	0.6(0.3)				20	16	55	45			11/9.5	11.5	
			4	1.6	0.14	0.3(0.15)				20	16	55	45			11/9.5	11.5	

\*1 : The voltage fluctuation range must be within ±10% of the rated voltage.

\*2 : For GFAG51, the max. working pressure differential with NO pressurized is shown in ( ).

\*3 : The leakage current must be less than or equal to the values shown below.

\*4 : Effective cross-sectional area S and sonic conductance C are converted as  $S \approx 5.0 \times C$ .

\*5 : The 100 VAC (50/60 Hz) can be used with 110 VAC (60 Hz).  
The 200 VAC (50/60 Hz) can be used with 220 VAC (60 Hz).

Leakage current	Voltage			
	Model No.	100 VAC	200 VAC	24 VDC
GFAG1	2 mA or less	1 mA or less	1 mA or less	2 mA or less
GFAG2	3 mA or less	1.5 mA or less		
GFAG3/4/5	6 mA or less	3 mA or less		

## Weight

Model No.	Actuator weight (kg)	Masking weight (kg)	Sub-plate weight (kg) (n: manifold station No.)	Formula for product weight
GFAG11	0.07	0.008	0.024+0.025×n	(Product weight (kg)) = 0.07 x (Actuator quantity) + 0.008 x (Masking quantity) + 0.024 + 0.025 x (Manifold station No.)
GFAG21	0.12	0.012	0.027+0.043×n	(Product weight (kg)) = 0.12 x (Actuator quantity) + 0.012 x (Masking quantity) + 0.027 + 0.043 x (Manifold station No.)
GFAG31	0.2	0.026	0.06+0.08×n	(Product weight (kg)) = 0.2 x (Actuator quantity) + 0.026 x (Masking quantity) + 0.06 + 0.080 x (Manifold station No.)
GFAG41	0.36	0.034	0.067+0.11×n	(Product weight (kg)) = 0.36 x (Actuator quantity) + 0.034 x (Masking quantity) + 0.067 + 0.11 x (Manifold station No.)
GFAG51	0.55	0.048	0.08+0.15×n	(Product weight (kg)) = 0.55 x (Actuator quantity) + 0.048 x (Masking quantity) + 0.08 + 0.15 x (Manifold station No.)

## How to order

● Manifold

**G F A G 2 1 - Z - 5 - 1 2C N - 1**

● Manifold with masking plate

**G F A G 3 1 - 1 - X - 1 2G N - 2 - 4 1**

No. of ports  
(3-port valve)  
Working fluid  
(Compressed air)

**A** Series size

**B** Circuit configuration

**C** Orifice size

**D** Manifold station No.

\*1  
\*2

**E** Body/sealant combination

**F** Coil option

\*3  
\*4  
\*5

**G** Manual operation

**H** Voltage

\*6

**I** No. of solenoid valves

\*7 valves

**J** Masking plate quantity

[Example of model No.]

**GFAG21-Z-5-12CN-1**

Model : GFAG

- A** Series size : 22 mm
- B** Circuit configuration : Common supply/common exhaust
- C** Orifice size : φ1
- D** Manifold station No. : 5 stations
- E** Body/sealant combination : Body - PPS, sealant - NBR
- F** Coil option : Grommet lead wire
- G** Manual override : Manual non-locking
- H** Voltage : 100 VAC50/60 Hz
- I** **J** : No masking plate

### ⚠ Precautions for model No. selection

- \*1 : Select a desired manifold station No. from 2 to 10.
- \*2 : For the type with masking plate, designate Item **D** as X, then designate the quantities of **I** solenoid valves and **J** masking plates.
- \*3 : For GFAG11 Item **F** 2G, the compact terminal box (G1/4) is used.
- \*4 : For GFAG21 **F** 2G/2HS, the DIN terminal box (Pg9) is used.
- \*5 : The surge suppressor is built into the coil for Item **F** 2CS and in the terminal box for 2HS and 3RS.
- \*6 : Other voltages may not be available. Contact CKD for details.
- \*7 : Solenoid valves are arranged from the right side with the sub-plate (individual) port A facing front.
- \*8 : Orders for only the masking plate and sub-plate are also available. Contact CKD for details.

		Model No.				
		GFAG11	GFAG21	GFAG31	GFAG41	GFAG51
Code	Content					
<b>A Series size</b>						
1	18 mm	●				
2	22 mm		●			
3	28 mm			●		
4	34 mm				●	
5	40 mm					●
<b>B Circuit configuration</b>						
1	Common supply/common exhaust	●	●	●	●	●
<b>C Orifice size</b>						
Y	φ0.8	●				
Z	φ1		●			
0	φ1.5	●		●		
1	φ2		●	●	●	●
4	φ3			●	●	●
8	φ4				●	●
<b>D Manifold station No.</b>						
2	2 stations					
to	to	●	●	●	●	●
10	10 stations					
O	Actuator only	●	●	●	●	●
X	With masking plate	●	●	●	●	●
<b>E Body/sealant combination</b>						
	<b>Body</b>	<b>Seal</b>				
1	PPS	NBR	●	●	●	●
<b>F Coil option</b>						
2C	Std.	Grommet lead wire	●	●	●	●
2CS	Option	Grommet lead wire with surge suppressor	●	●	●	●
2G		With DIN terminal box (Pg11)	●	●	●	●
2HS		DIN terminal box with lamp/surge suppressor (Pg11)		●	●	●
2CG		Conduit (CTC19)			●	●
2CH		Conduit (G1/2)			●	●
3T		With T type terminal box (G1/2)				●
3RS		T type terminal box with lamp/surge suppressor (G1/2)				●
<b>G Manual operation</b>						
Blank	Std.	None	●	●	●	●
N	Option	Manual non-locking	●	●	●	●
<b>H Voltage</b>						
1	100 VAC 50/60 Hz	●	●	●	●	●
2	200 VAC 50/60 Hz	●	●	●	●	●
3	24 VDC	●	●	●	●	●
4	12 VDC	●	●	●	●	●
Specify the desired voltage if it is not listed above.						
<b>I No. of solenoid valves</b>						
Blank	No masking plate		●	●	●	●
1	1 solenoid valve	to	●	●	●	●
9	9 solenoid valves					
<b>J Masking plate quantity</b>						
Blank	No masking plate		●	●	●	●
1	1 masking plate	to	●	●	●	●
9	9 masking plates					

Select from the combinations indicated with ● in the table above.

- EXA
- FWD
- HNB/G
- USB/G
- FAB/G
- FGB/G
- FVB
- FWB/G
- FHB
- FLB
- AB
- AG
- AP/AD
- APK/ADK
- DryAir
- EX-XPLNprf
- XPLNprf
- HVB/HVL
- SΔB/NAB
- LAD/NAD
- Water-Rela
- NP/NAP/NVP
- SNP
- CHB/G
- MXB/G
- Other valves
- SWD/MWD
- DustColl
- CVE/CVSE
- CCH/CPE/D
- LifeSci
- Gas-Combust
- Auto-Water
- SpecFld
- Custom
- Ending

## Internal structure and parts list

- EXA
- FWD
- HNB/G
- USB/G
- FAB/G**
- FGB/G
- FVB
- FWB/G
- FHB
- FLB
- AB
- AG
- AP/  
AD
- APK/  
ADK
- DryAir
- EX-  
XPLNprf
- XPLNprf
- HVB/  
HVL
- S $\nabla$ B/  
NAB
- LAD/  
NAD
- Water-  
Rela
- NP/NAP/  
NVP
- SNP
- CHB/G
- MXB/G
- Other  
valves
- SWD/  
MWD
- DustColl
- CVE/  
CVSE
- CCH /  
CPE/D
- LifeSci
- Gas-  
Combus
- Auto-  
Water
- SpecFld
- Custom
- Ending

● GFAG actuator

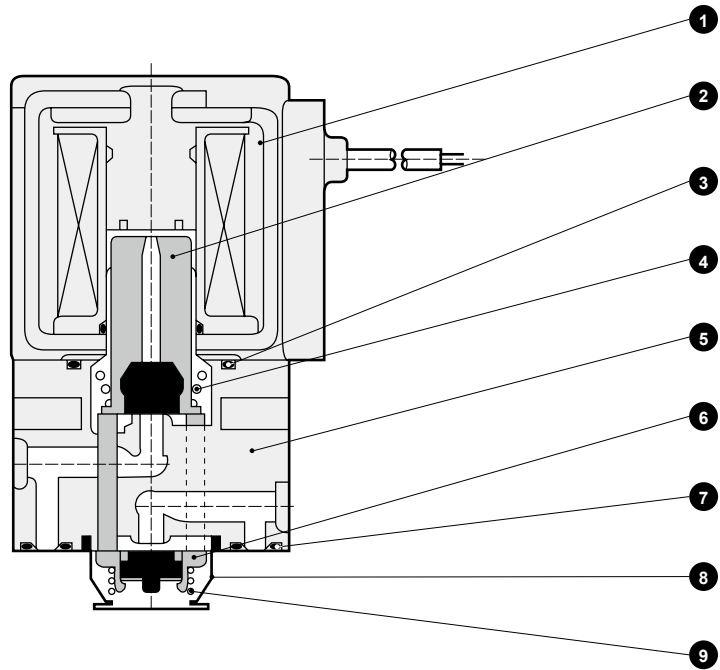

● GFAG manifold

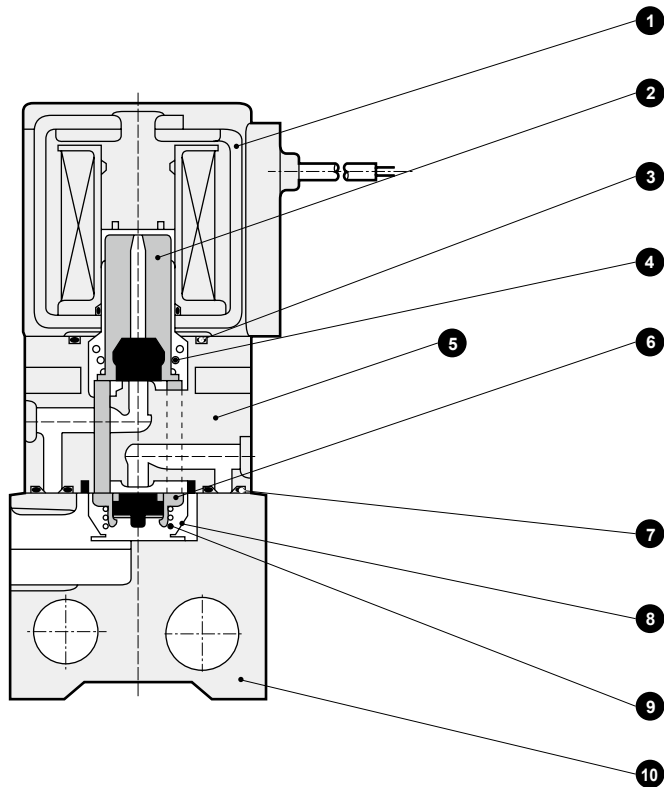

No.	Part name	Material	No.	Part name	Material
1	Coil assembly	-	6	Valving element guide assembly	PPS, SUS, NBR : Polyphenylene sulfide, stainless steel, nitrile rubber
2	Plunger assembly	SUS, NBR	7	Gasket	NBR : Nitrile rubber
3	O-ring	NBR	8	Holder	SUS : Stainless steel
4	Spring	SUS	9	Spring	SUS : Stainless steel
5	Body	PPS	10	Sub-plate	A6063 : Aluminum

\* 4 body mounting screws and 2 O-rings are attached to the actuator only.

## Dimensions: Manifold



- Grommet lead wire  
GFAG\*1-\*-\*-12C

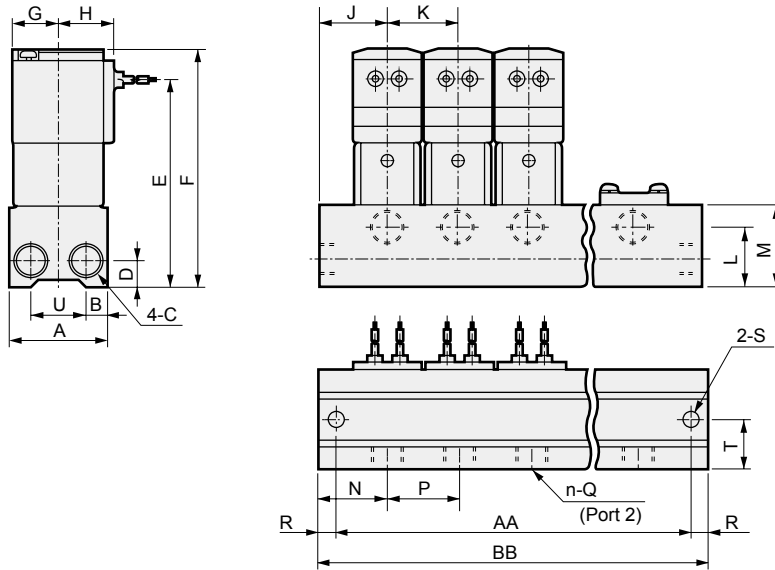

Lead wire length 300 mm

Model No.	Station Code	2	3	4	5	6	7	8	9	10
GFAG1	AA	48	68	88	108	128	148	168	188	208
	BB	58	78	98	118	138	158	178	198	218
GFAG2	AA	58	84	110	136	162	188	214	240	266
	BB	68	94	120	146	172	198	224	250	276
GFAG3	AA	74	106	138	170	202	234	266	298	330
	BB	88	120	152	184	216	248	280	312	344
GFAG4	AA	86	124	162	200	238	276	314	352	390
	BB	100	138	176	214	252	290	328	366	404
GFAG5	AA	100	146	192	238	284	330	376	422	468
	BB	114	160	206	252	298	344	390	436	482

Model No.	A	B	C	D	E	F	G	H	J	K	L	M	N	P	Q	R	S	T	U
GFAG1	30	6.5	Rc1/8	8	55.5	65	13	17	19	20	16	22	18.5	20	M5	5	φ4.5	15	17
GFAG2	30	6.5	Rc1/8	8	70	81	15.5	19.5	21	26	18	27	20	26	Rc1/8	5	φ4.5	15	17
GFAG3	40	9	Rc1/4	11	84	96	18.5	22.5	28	32	24	33	27.5	32	Rc1/4	7	φ6.5	20	22
GFAG4	43	9	Rc1/4	11	93.5	107.5	22.5	26	31	38	24	33	34.5	38	Rc1/4	7	φ6.5	21.5	25
GFAG5	50	10	Rc1/4	11	100	116	26	29.5	34	46	24	33	38.5	46	Rc1/4	7	φ6.5	25	30

## Dimensions: Actuator



- Grommet lead wire  
GFAG\*1-\*-0-12C

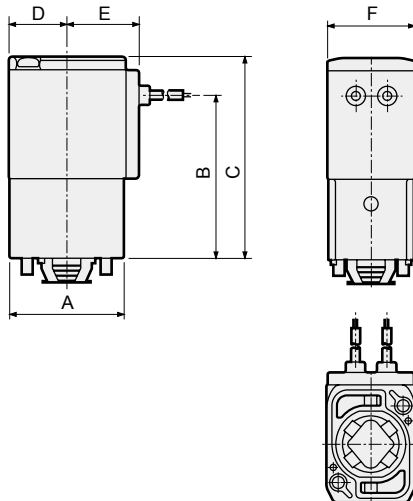

Model No.	A	B	C	D	E	F
GFAG1	25	33.5	43	13	17	18
GFAG2	30	43	54	15.5	19.5	22
GFAG3	36	51	63	18.5	22.5	28
GFAG4	43	60.5	74.5	22.5	26	34
GFAG5	50	67	83	26	29.5	40

\* Lead wire length 300 mm

- EXA
- FWD
- HNB/G
- USB/G
- FAB/G
- FGB/G
- FVB
- FWB/G
- FHB
- FLB
- AB
- AG
- AP/AD
- APK/ADK
- DryAir
- EX-XPLNprf
- XPLNprf
- HVB/HVL
- SAB/NAB
- LAD/NAD
- Water-Rela
- NP/NAP/NVP
- SNP
- CHB/G
- MXB/G
- Other valves
- SWD/MWD
- DustColl
- CVE/CVSE
- CCH/CPE/D
- LifeSci
- Gas-Combus
- Auto-Water
- SpecFld
- Custom
- Ending

## Actuator installation dimensions

### ● GFAG1\*/2\*/3\*

Machining drawing when using 2 actuators.

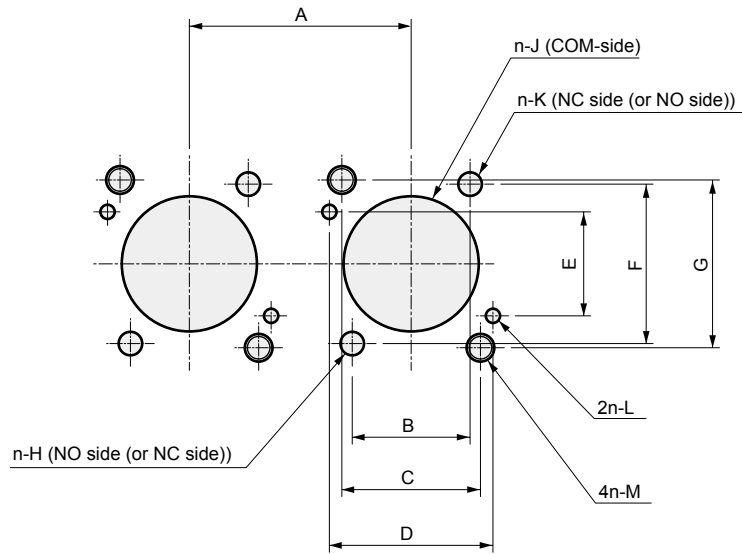

Model No.	A	B	C	D	E	F	G	H	J	K	L	M
GFAG1	20 or more	9±0.15	12.4±0.1	14.4±0.1	11.2±0.1	16.4±0.15	17±0.1	φ2 <sup>+0.1</sup> <sub>0</sub>	φ12 ±0.1 depth 7 <sup>+0.2</sup> <sub>0</sub>	φ2 <sup>+0.1</sup> <sub>0</sub>	φ1.6 <sup>+0.1</sup> <sub>0</sub> depth 2.5±0.5	M2.5 effective depth 5
GFAG2	26 or more	12±0.15	15.5±0.1	18.4±0.1	12.4±0.1	20±0.15	19.4±0.1	φ2.5 <sup>+0.1</sup> <sub>0</sub>	φ14.5 ±0.1 depth 6.7 <sup>+0.2</sup> <sub>0</sub>	φ2.5 <sup>+0.1</sup> <sub>0</sub>	φ1.6 <sup>+0.1</sup> <sub>0</sub> depth 2.5±0.5	M3 effective depth 6
GFAG3	32 or more	17±0.15	20±0.1	23.6±0.1	15±0.1	24±0.15	24.2±0.1	φ3.4 <sup>+0.1</sup> <sub>0</sub>	φ19.5 ±0.1 depth 7.6 <sup>+0.2</sup> <sub>0</sub>	φ3.4 <sup>+0.1</sup> <sub>0</sub>	φ2.1 <sup>+0.1</sup> <sub>0</sub> depth 2.5±0.5	M4 effective depth 6

### ● GFAG4\*/5\*

Machining drawing when using 2 actuators.

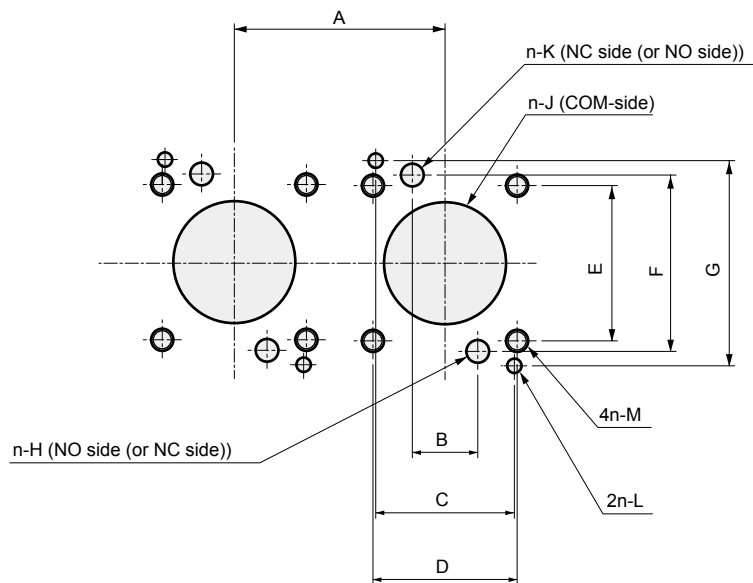

Model No.	A	B	C	D	E	F	G	H	J	K	L	M
GFAG4	38 or more	11.8±0.15	25±0.1	26±0.1	28±0.1	31.8±0.15	37±0.1	φ4.1 <sup>+0.1</sup> <sub>0</sub>	φ22 ±0.15 depth 11.2 <sup>+0.2</sup> <sub>0</sub>	φ4.1	φ2.6 depth 2.5±0.5 <sup>+0.1</sup> <sub>0</sub>	M4 effective depth 12
GFAG5	46 or more	11.8±0.15	30±0.1	30±0.1	33±0.1	31.8±0.15	43±0.1	φ4.1 <sup>+0.1</sup> <sub>0</sub>	φ22 ±0.15 depth 11.2 <sup>+0.2</sup> <sub>0</sub>	φ4.1	φ2.6 depth 2.5±0.5 <sup>+0.1</sup> <sub>0</sub>	M5 effective depth 8

## Optional dimensions

(Refer to the grommet lead wire actuator dimensions on page 71 for common dimensions.)

- Grommet lead wire with surge suppressor  
GFAG\*1-\*\*-1 **2CS**

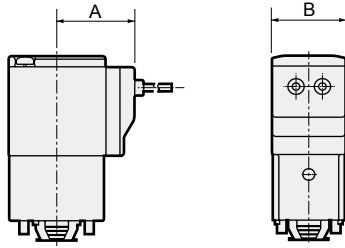

Model No.	A	B
GFAG1	24.5	18
GFAG2	26.5	22
GFAG3	29.5	28
GFAG4	34	34
GFAG5	37.5	40

- Conduit (CTC19 / G1/2)  
GFAG\*1-\*\*-1 **2CG**  
**2CH**

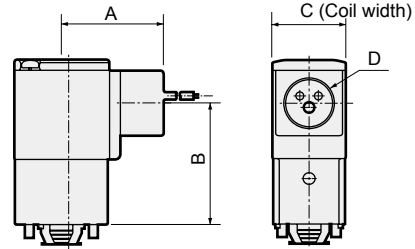

Model No.	A	B	C	D
GFAG3	39	46	28	CTC19 / G1/2
GFAG4	43	56	34	CTC19 / G1/2
GFAG5	46.5	64	40	CTC19 / G1/2

- DIN terminal box (with lamp/surge suppressor)  
GFAG\*1-\*\*-1 **2G**  
**2HS**

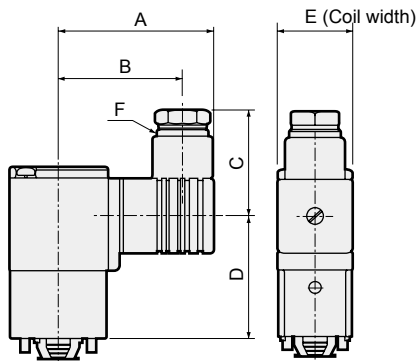

Model No.	A	B	C	D	E	F
GFAG1	36	28.5	22	31.5	18	G1/4
GFAG2	53	44	38	36.5	22	Pg9
GFAG3	58.5	47	39	44.5	28	Pg11
GFAG4	62	50.5	39	54	34	Pg11
GFAG5	65.5	54	39	62.5	40	Pg11

- T type terminal box (with lamp/surge suppressor) (G1/2)  
GFAG\*1-\*\*-1 **3T**  
**3RS**

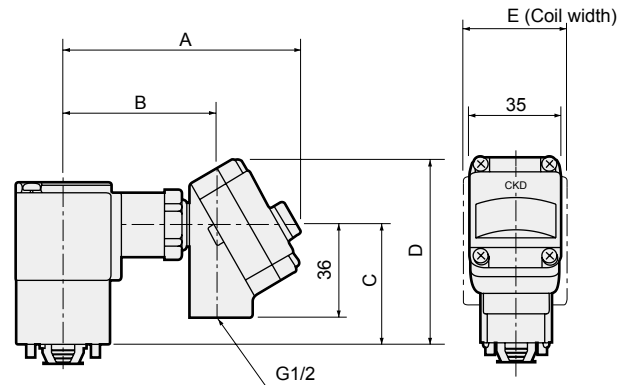

Model No.	A	B	C	D	E
GFAG4	96	64.5	56	82	34
GFAG5	99.5	68	64	90	40

- Manual override (non-locking)  
GFAG\*1-\*\*-\*\* **N**

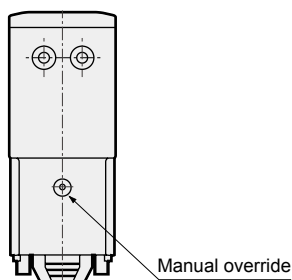

Position of manual override:  
Opposite side to COM port

EXA
FWD
HNB/G
USB/G
FAB/G
FGB/G
FVB
FWB/G
FHB
FLB
AB
AG
AP/ AD
APK/ ADK
DryAir
EX- XPLNprf
XPLNprf
HVB/ HVL
S $\nabla$ B/ NAB
LAD/ NAD
Water- Rela
NP/NAP/ NVP
SNP
CHB/G
MXB/G
Other valves
SWD/ MWD
DustCoil
CVE/ CVSE
CCH / CPE/D
LifeSci
Gas- Combus
Auto- Water
SpecFld
Custom
Ending