

Lubricator/econo-mist

3003E/3004E/3005E Series

Supplying fine oil mist (oil fog).

● Port size: Rc 3/4 to Rc2

JIS symbol

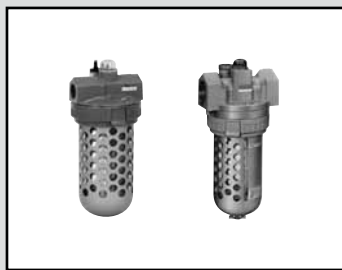

Specifications

Descriptions	3003E-6C/8C	3004E-10C/12C	3005E-16C
Appearance			
Working fluid	Compressed air		
Max. working pressure	1.0 (≈150 psi, 10 bar)		
Proof pressure	1.5 (≈220 psi, 15 bar)		
Ambient / fluid temperatures	5 (41°F) to 65 (149°F)		
Oil used	Turbine oil Class 1, ISO VG32 (spindle oil cannot be used)		
Oil storage capacity	660	660	660
Port size	Rc 3/4, 1	1 1/4, 1 1/2	2
Weight	2.4	3.5	4.5
Bowl guard	Standard equipment		
Min. drip flow rate	60	200	200

*1: The min. drip flow rate is the value at which five drops of oil drip per minute when the primary pressure is 0.5 MPa.

Oil drip rate

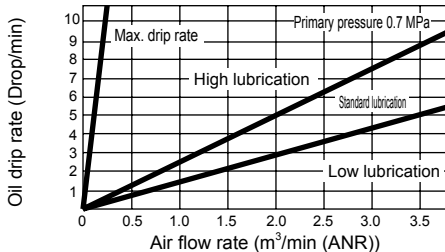

Option weight

* Add to the weight of the standard accessories.

Unit: kg

Code	Drain disch		Bowl material				
	C	Z	M	MG	MG2	MG8	MG20
3003E	0	-0.025	0	0.17	8	18	28
3004E	0	-0.025	0	0.17	7	17	27
3005E	0	-0.025	0	0.17	7	17	27

Flow characteristics

● 3003E-6C

Rc3/4

● 3003E-8C

Rc1

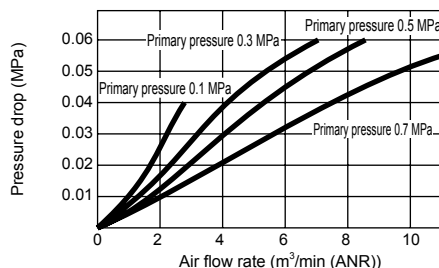
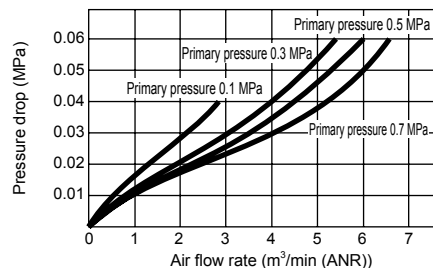

● 3004E-10C

Rc1 1/4

● 3004E-12C

Rc1 1/2

● 3005E-16C

Rc2

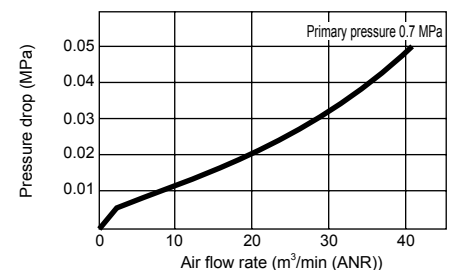
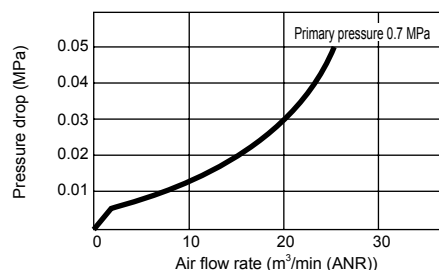
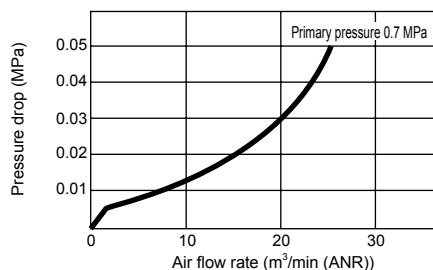

How to order

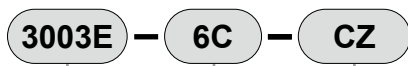

A Model No.

B Port size
*1

C Option
*2
*3
*4

		A Model No.			
		Large	Large bore	Large bore	
Code	Content	3003E	3004E	3005E	
B Port size					
6C	Rc ³ / ₄	●			
8C	Rc1	●			
10C	Rc1 ¹ / ₄		●		
12C	Rc1 ¹ / ₂		●		
16C	Rc2			●	
C Option					
Drain discharge	Blank	Blank bowl	●	●	●
	C	Manual cock (M/MG: Cock)	●	●	●
Bowl material	Blank	Polycarbonate	●	●	●
	Z	Nylon bowl	●	●	●
	M	Metal bowl	●	●	●
	MG	Metal bowl with gauge	●	●	●
	MG2	Metal bowl for 2 ℓ	●	●	●
	MG8	Metal bowl for 8 ℓ	●	●	●
	MG20	Metal bowl for 20 ℓ	●	●	●

[Example of model No.]

3003E-6C-CZ

Model: Lubricator/econo-mist

A Model No.: Large

B Port size: Rc ³/₄

C Option: Manual cock, nylon bowl

⚠ Precautions for model No. selection

- *1: If port size NPT thread is required, do not indicate nominal size C. (Example) 3003E-6
- *2: Quart bowl for 2ℓ to 20ℓ is a custom order product. Combination with a bracket is not possible.
- *3: Consult with CKD when using the air motor with a uniform flow rate (minimal differential pressure).
- *4: The observation dome material is polyamide resin (nylon) even when a metal bowl is selected.

F.R.L
F (Filtr)
R (Reg)
L (Lub)
PresSW
Shutoff
SlowStart
FimResistFR
Oil-ProhR
MedPresFR
No Cu/ PTFE FRL
Outdrs FR
F.R.L (Related)
CompFRL
LgFRL
PrecsR
VacF/R
Clean FR
ElecPneuR
AirBoost
SpdContr
Silncr
CheckV/ other
Jnt/tube
AirUnt
PrecsCompn
Mech/ ElecPresSw
ContactSW
AirSens
PresSW Cool
AirFloSens/ Contr
WaterRtSens
TotAirSys (Total Air)
TotAirSys (Gamma)
RefrDry
DesicDry
HiPolymDry
MainFiltr
Dischrg etc
Ending

3003E/3004E/3005E Series

F.R.L Internal structure and parts list

- F (Filtr)
- R (Reg)
- L (Lub)
- PresSW
- Shutoff
- SlowStart
- FimResistFR
- Oil-ProhR
- MedPresFR
- No Cu/PTFE FRL
- Outdrs FR
- F.R.L (Related)
- CompFRL
- LgFRL**
- PrecsR
- VacFR
- Clean FR
- ElecPneuR
- AirBoost
- SpdContr
- Silncr
- CheckV/other
- Jnt/tube
- AirUnt
- PrecsCompn
- Mech/ElecPresSw
- ContactSW
- AirSens
- PresSW Cool
- AirFloSens/Contr
- WaterRtSens
- TotAirSys (Total Air)
- TotAirSys (Gamma)
- RefrDry
- DesicDry
- HiPolymDry
- MainFiltr
- Dischrg etc
- Ending

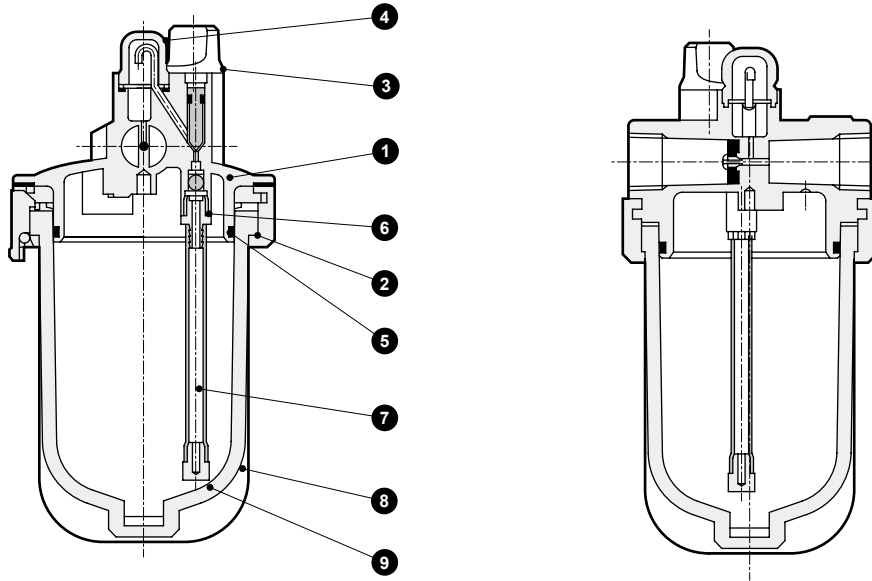

No.	Part name	Material		
		3003E	3004E	3005E
1	Body	Zinc alloy die-casting		
2	Clamp ring	Zinc alloy die-casting		
3	Filling plug	Polyacetal resin	Copper alloy	
4	Observation dome	Polycarbonate resin		
5	O-ring	Special nitrile rubber		
6	Adaptor	Copper alloy		
7	Siphon tube assembly	Polyamide resin, polypropylene		
8	Bowl guard	Steel		
9	Bowl	Polycarbonate resin		

Functions

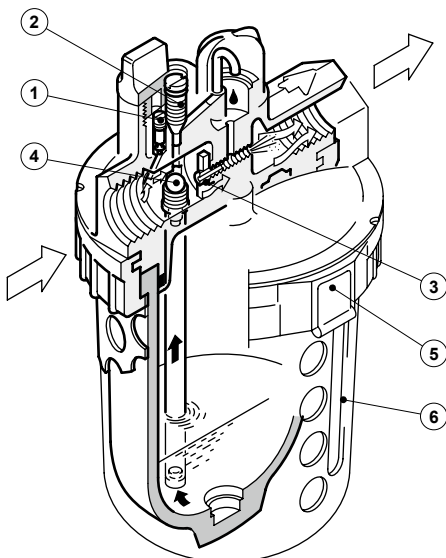

- (1) Pressure valve: Compressed air is supplied in a bowl. If filling plug is loosened, the pressure valve is closed to allow re-filling lubricant without stopping the pneumatic circuit.
* Caution: Loosen the filling plug first and remove the plug after the pressure in the bowl is released. Then refill the lubricant.
- (2) Oil rate adjustment needle: Adjust oil rate supplied to compressed air. Needle with a special shape is used to adjust the oil rate accurately. One drop of oil is approx. 0.02 cm³.
- (3) Flow guide: Constant proportion of compressed air vs. oil rate is maintained in both large and small flow rates to supply oil fog to pneumatic components.
- (4) Check valve: Lubricant in the bowl flows into the drip tube passing through the siphon tube. Check valve inside prevents oil from flowing backward.
- (5) Clamp ring: Push-in clamp ring is used to achieve easy bowl washing and lubrication from bowl.
- (6) Bowl guard: Lubricant volume can be checked through the oval hole, enabling maintenance to be performed easily. Even if the bowl breaks, its shards will not scatter.

3003E/3004E/3005E Series

Dimensions

Dimensions



- 3003E
- 3004E
- 3005E

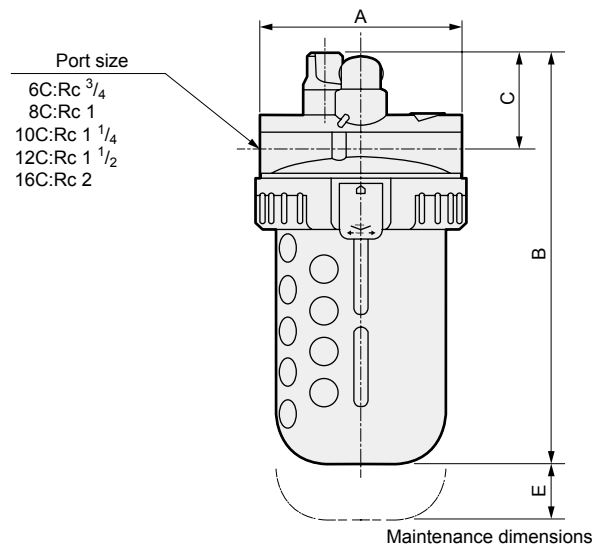
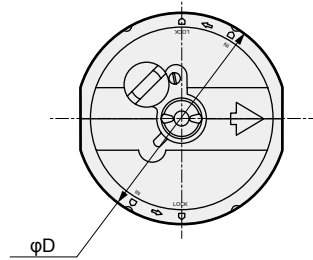

Model No.		3003E	3004E	3005E	
B	A	118	140	140	
	Combination option	Blank	259	291	314
		C	289	322	339
		M/MG	261	294	310
		CM/CMG	275	308	324.5
C	50	58	67		
D	118	114	127		
E	200	200	200		

- Pipe bracket: 6132

· Material: Steel
Zinc plated

Bracket - Pipe bracket thickness 4.5 mm

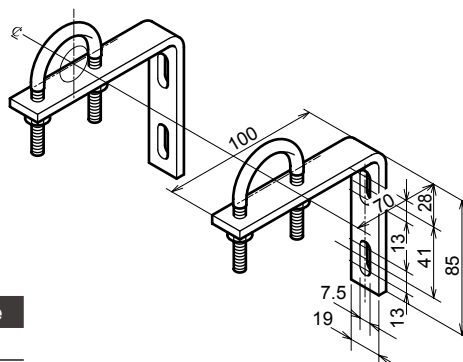

Model No.	Port size
6132-6C	3/4B
6132-8C	1B

- F.R.L
- F (Filtr)
- R (Reg)
- L (Lub)
- PresSW
- Shutoff
- SlowStart
- FmResistFR
- Oil-ProhR
- MedPresFR
- No Cu/ PTFE FRL
- Outdrs FR
- F.R.L (Related)
- CompFRL
- LgFRL**
- PrecsR
- VacF/R
- Clean FR
- ElecPneuR
- AirBoost
- SpdContr
- Silncr
- CheckV/ other
- Jnt/tube
- AirUnt
- PrecsCompn
- Mech/ ElecPresSw
- ContactSW
- AirSens
- PresSW Cool
- AirFloSens/ Contr
- WaterRtSens
- TotAirSys (Total Air)
- TotAirSys (Gamma)
- RefrDry
- DesicDry
- HiPolymDry
- MainFiltr
- Dischrg etc
- Ending



3003E Series

Lubricator/auto-fill

Only installing oil tank enables automatic lubrication to multiple lubricators.

● Port size: Rc 1/4 to Rc1

JIS symbol



Specifications

Descriptions	3003E-6C/8C-V	
Working fluid	Compressed air	
Max. working pressure	MPa	1.0 (≈150 psi, 10 bar)
Proof pressure	MPa	1.5 (≈220 psi, 15 bar)
Ambient / fluid temperatures	°C	5 (41°F) to 65 (149°F)
Lubrication pressure	MPa	Working pressure plus 0.035 (≈5.1 psi, 0.35 bar) to 0.35 (≈51 psi, 3.5 bar)
Oil used	Turbine oil Class 1, ISO VG32 (spindle oil cannot be used)	
Port size	Rc	³ / ₄ , 1
Weight	kg	2.5
Bowl guard	Standard equipment	

Option weight

* Add to the weight of the standard accessories.

Unit: kg

Code	Bowl material		
	Z	M	MG
3003E-V	-0.025	0	0.17

How to order

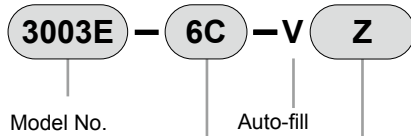

Code	Content	
A Port size		
6C	Rc ³ / ₄	
8C	Rc1	
B Option		
Bowl material	Blank	Polycarbonate
	Z	Nylon bowl
	M	Metal bowl
	MG	Metal bowl with gauge

⚠ Precautions for model No. selection

*1: If port size NPT thread is required, do not indicate nominal size C.
(Example) 3003E-6-V

[Example of model No.]

3003E-6C-Z

Model: Lubricator/auto-fill

● A Port size: Rc ³/₄

● B Option: Nylon bowl

Functions

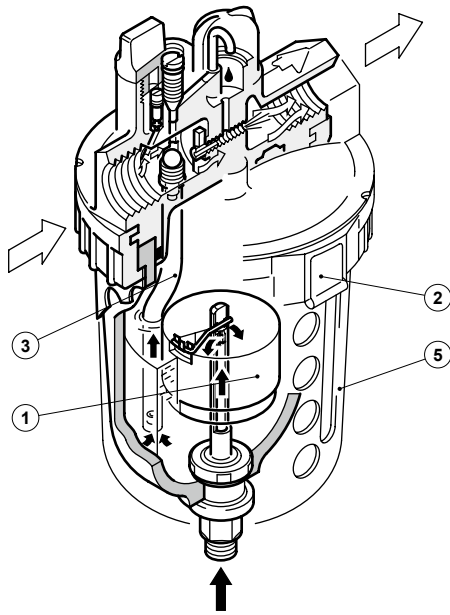

- (1) Float: The float using rubber foam detects a decrease of lubricant by its buoyancy and opens the orifice seat by the level arm to supply lubricant.
- (2) Clamp ring: A push-in clamp ring is used to achieve easy washing, maintenance and inspection of bowl.
- (3) Siphon tube: Uniquely shaped siphon tube is designed not to make contact with the float. Re-assemble the tube not to contact to the float after washing.
- (4) Stop valve: Always use the stop valve for bowl washing or maintenance to avoid jetting lubricant. No stop valve is installed to the product.
- (5) Bowl guard: Even if the bowl breaks, operator safety will be maintained. Drainage remaining and the internal state can be checked through the oval hole.

Dimensions

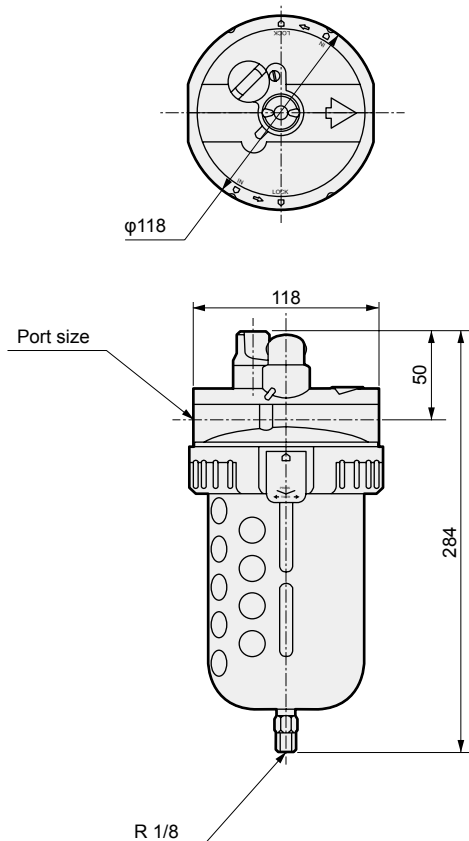

Standard piping

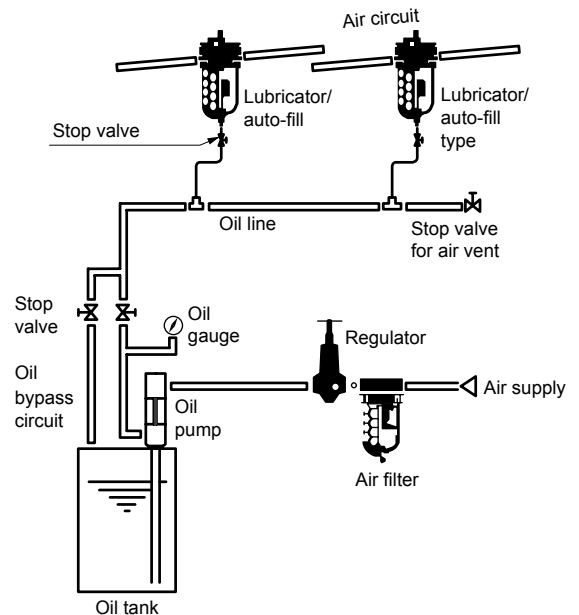

- (1) Always use zinc plating steel tube for an oil line.
- (2) Install an oil line as near as possible to the auto-fill lubricator.
- (3) Connect auto-fill lubricator with flexible tube (1m or below).
- (4) Always install a stop valve for the air vent to the end of the oil line.
- (5) Oil supply pressure to auto-fill lubricator is to be 0.035 to 0.35 MPa higher than air pressure of lubricator.

F.R.L
F (Filtr)
R (Reg)
L (Lub)
PresSW
Shutoff
SlowStart
FimResistFR
Oil-ProhR
MedPresFR
No Cu/ PTFE FRL
Outdrs FR
F.R.L (Related)
CompFRL
LgFRL
PrecsR
VacF/R
Clean FR
ElecPneuR
AirBoost
SpdContr
Silncr
CheckV/ other
Jnt/tube
AirUnt
PrecsCompn
Mech/ ElecPresSw
ContactSW
AirSens
PresSW Cool
AirFloSens/ Contr
WaterRISens
TotAirSys (Total Air)
TotAirSys (Gamma)
RefrDry
DesicDry
HiPolymDry
MainFiltr
Dischrg etc
Ending