



Speed controller Large bore size

SC Series

● Port size: Rc3/4 to Rc2

JIS symbol

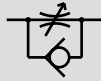

Specifications

Descriptions	SC-20A	SC-25A	SC-32A	SC-40A	SC-50A	
Working fluid	Compressed air					
Max. working pressure MPa	1.0 (≈150 psi, 10 bar)		0.7 (≈100 psi, 7 bar)			
Min. working pressure MPa	0.05 (≈7.3 psi, 0.5 bar)		0.05 (≈7.3 psi, 0.5 bar)			
Proof pressure MPa	1.5 (≈220 psi, 15 bar)		1.05 (≈150 psi, 10.5 bar)			
Fluid temperature °C	5 (41°F) to 60 (140°F) (no freezing) *2					
Ambient temperature °C	0 (32°F) to 60 (140°F) (no freezing)					
Port size Rc	3/4	1	1 1/4	1 1/2	2	
Weight kg	0.8	1.4	4.0	4.0	4.0	
Cylinder bore size mm	φ100 to φ200	φ140 to φ250	φ300 to φ450	φ300 to φ450	φ450 to	
Dial indicator value	10	10	10	10	10	
Mounting orientation	The handle (nut) for flow control must be installed vertically facing upward or downward.					
Free flow	Flow rate l/min(ANR)	10300	17400	68000	68000	97000
	Eff. X-sectional area mm ²	155	260	1000	1000	1500
Controlled flow	Flow rate l/min(ANR)	8300	18700	68000	68000	91000
	Eff. X-sectional area mm ²	125	280	1000	1000	1400

*1: Flow rate is the atmospheric pressure conversion at 0.5 MPa.

*2: Freezing may occur due to adiabatic expansion depending on the air quality (dew point).

How to order

SC — 20A

A Port size

Code	Content
A Port size	
20A	Rc3/4
25A	Rc1
32A	Rc1 1/4
40A	Rc1 1/2
50A	Rc2

Flow characteristics

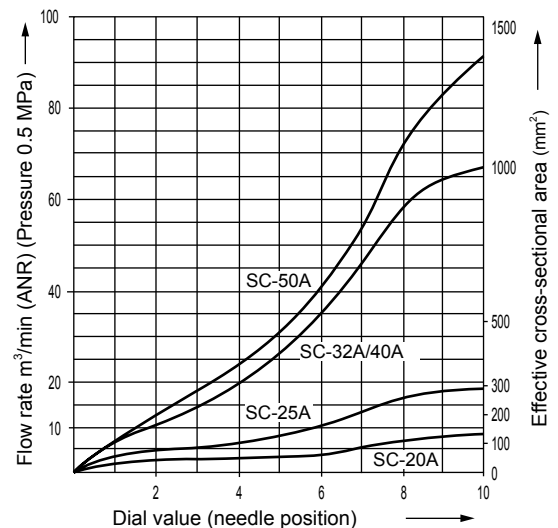

Internal structure and parts list

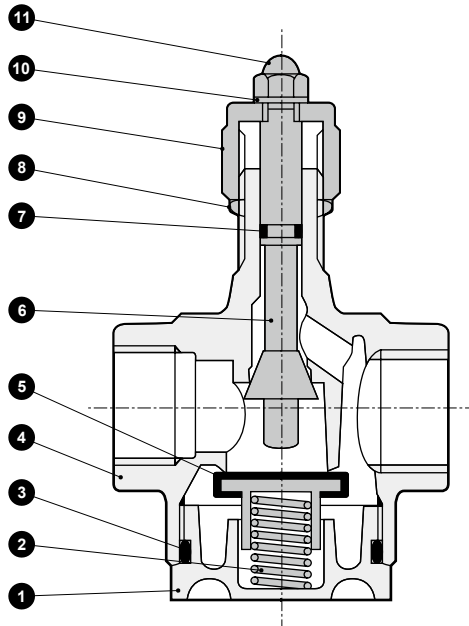

No.	Part name	Material
1	Cap	Zinc die-casting
2	Spring	Stainless steel
3	O-ring	Nitrile rubber
4	Body	Zinc die-casting
5	Valve seat	Copper alloy/nitrile rubber
6	Rod	Copper alloy
7	O-ring	Nitrile rubber
8	Nut	Carbon steel or copper alloy
9	Nut	Zinc die-casting
10	Internal star washer	Stainless steel
11	Cap nut	Steel

Dimensions



● SC- 20 A
25

● SC- 32 A
40 A
50

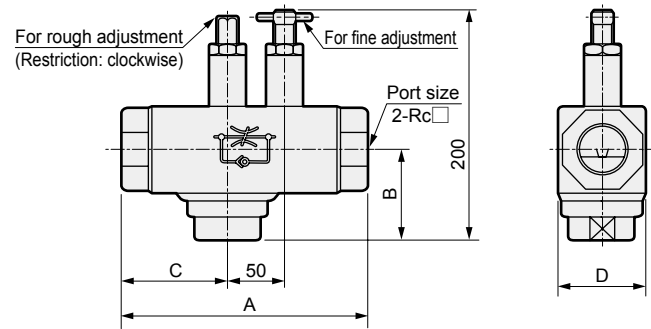
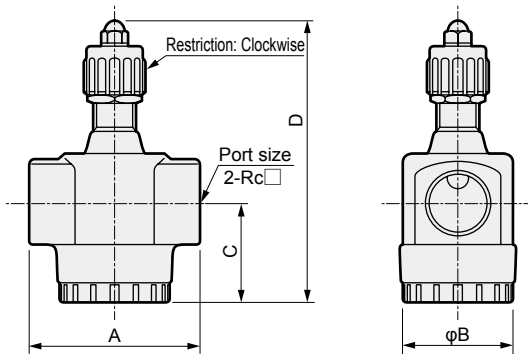

Model No.	A	B	C	D	Port size
SC-20A	74	50	42	115	Rc3/4
SC-25A	90	61	55	156	Rc1

Model No.	A	B	C	D	Port size
SC-32A	210	77	92	75	Rc1 1/4
SC-40A	210	77	92	75	Rc1 1/2
SC-50A	222	79	96	84	Rc2

⚠ Safety precautions

When connecting the SC Series, do not tighten the product with a torque greater than what is listed on the right.

- When operating in the low pressure range (0.05 MPa or less), or when the piping, etc., before and after the product are excessively constricted, note that vibrating sounds can be easily generated if the cylinder speed is rapid, or if the differential pressure is small.
- When tightening, do not tighten the needle or lock nut section excessively. (Tightening torque approx. 3 N·m)

Port thread	Tightening torque N·m
Rc3/4	51
Rc1	70
Rc1 1/4	80
Rc1 1/2	85
Rc2	120

- F.R.L
- F (Filtr)
- R (Reg)
- L (Lub)
- PresSW
- Shutoff
- SlowStart
- FimResistFR
- Oil-ProhR
- MedPresFR
- No Cu/ PTFE FRL
- Outdrs FR
- F.R.L (Related)
- CompFRL
- LgFRL
- PrecsR
- VacF/R
- Clean FR
- ElecPneuR
- AirBoost
- SpdContr
- Silncr
- CheckV/ other
- Jnt/tube
- AirUnt
- PrecsCompn
- Mech/ ElecPresSw
- ContactSW
- AirSens
- PresSW Cool
- AirFloSens/ Contr
- WaterRtSens
- TotAirSys (Total Air)
- TotAirSys (Gamma)
- RefrDry
- DesicDry
- HiPolymDry
- MainFiltr
- Dischrg etc
- Ending