



Miniature speed controller SC-M3/M5

Compact and lightweight enabling space-saving piping. Low speed and fine speed are available.

JIS symbol

SC-M5-S
SC-M5-F

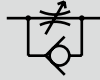

SC-M5-L
SC-M5-A



Specifications

Descriptions	SC-M3-S	SC-M3-L	SC-M3-F	SC-M3-A	SC-M5-S	SC-M5-L	SC-M5-F	SC-M5-A	
Working fluid	Compressed air								
Max. working pressure MPa	0.7 (≈100 psi, 7 bar)								
Min. working pressure MPa	0.1 (≈15 psi, 1 bar)								
Proof pressure MPa	1.05 (≈150 psi, 10.5 bar)								
Fluid temperature °C	5 (41°F) to 60 (140°F) (no freezing) *1								
Ambient temperature °C	0 (32°F) to 60 (140°F) (no freezing)								
Port size	M3				M5				
Weight g	1.7	1.5	2.4	2.4	5.6(6)	4.8(5.2)	7.9(8.3)	8.5(8.9)	
Cylinder bore size mm	φ2.5 to φ10				φ6 to φ25				
Dial indicator value	10				10(14)				
Free flow	Flow rate l/min(ANR)	20				53			
	Eff. X-sectional area mm ²	0.3				0.8			
Controlled flow	Flow rate l/min(ANR)	16				47(6.7)			
	Eff. X-sectional area mm ²	0.25				0.7(0.1)			

*1: Freezing may occur due to adiabatic expansion depending on the air quality (dew point).

*2: Flow rate is the atmospheric pressure conversion at 0.5 MPa.

*3: Values in () indicate fine speed.

Flow characteristics

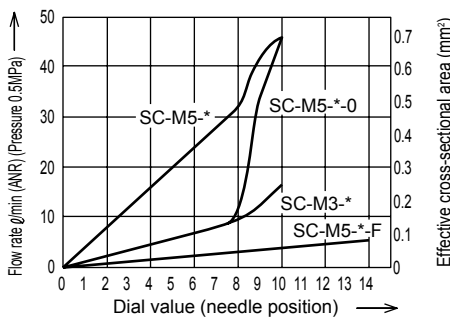

How to order



Code	Content
A Port size	
M3	M3×0.5
M5	M5×0.8
B Shape	
S	Straight
L	Elbow
F	Flat
A	Adjustable
C Control method	
Blank	Meter-out
I	Meter-in
D Flow characteristics	
Blank	Standard
O	Low speed (M5 only)
F	Fine speed (M5 only)

*1: For fine speed, the lock nut exterior is blue.

2: Not available for SC--S-I. Install SC-*-S with reverse-mounted IN and OUT.

Internal structure and parts list

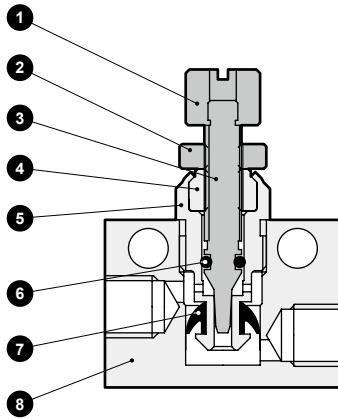

No.	Part name	Material
1	Knob	Aluminum alloy
2	Lock nut	Aluminum alloy
3	Needle	Stainless steel
4	Needle guide	Aluminum alloy
5	Check bracket	Aluminum alloy
6	O-ring	Nitrile rubber
7	Packing	Hydrogenated nitrile rubber
8	Body	Aluminum alloy

Note: For fine speed, the material of the needle guide is stainless steel.

Dimensions



● SC-M3/M5 -S (straight)

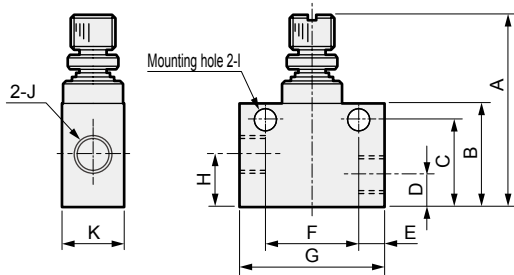

Model No.	A	B	C	D	E	F	G	H	I	J	K
SC-M3-S	18.5(max21)	9	7.3	2.5	2.5	8	13	4.2	φ2.2	M3×0.5	5
SC-M5-S	25(max28.5)	13.5	11.2	4.2	3.5	12	19	6.5	φ3.2	M5×0.8	8

● SC-M3/M5 -L (elbow)

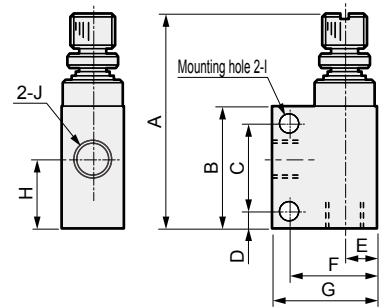

Model No.	A	B	C	D	E	F	G	H	I	J
SC-M3-L	20.3(max22.8)	10.5	7	1.9	2.5	6.5	9	5.7	φ2.2	M3×0.5
SC-M5-L	27.5(max31)	16	11.5	2.2	4.3	11.2	13.5	9	φ3.2	M5×0.8

● SC-M3/M5 -F (flat)

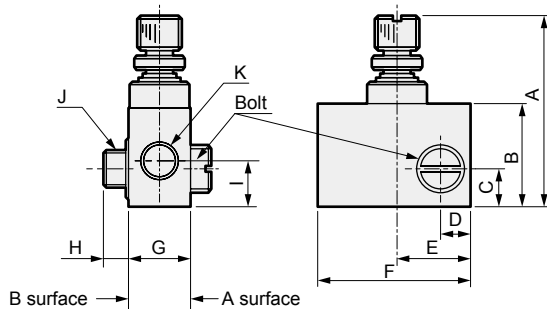

Model No.	A	B	C	D	E	F	G	H	I	J	K
SC-M3-F	18.5(max21)	9	3.4	2.7	6.5	13	5	3	4.2	M3×0.5	M3×0.5
SC-M5-F	25(max28.5)	13.5	5.1	4	10.5	20	8	3.5	6.5	M5×0.8	M5×0.8

Note: The bolt can be removed from the main body and installed from either A or B surfaces.

● SC-M3/M5 -A (adjustable)

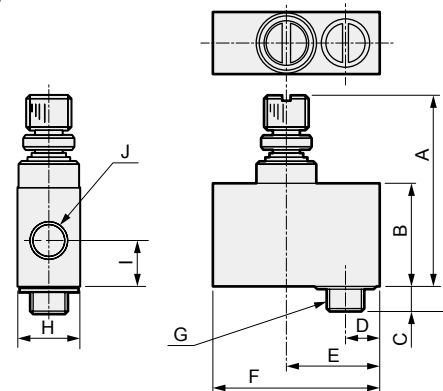

Model No.	A	B	C	D	E	F	G	H	I	J
SC-M3-A	18.5(max21)	9	3	3.2	8	14.5	M3×0.5	5	4.2	M3×0.5
SC-M5-A	25(max28.5)	13.5	3.5	4.5	12.5	22	M5×0.8	8	6.5	M5×0.8

F.R.L
F (Filtr)
R (Reg)
L (Lub)
PresSW
Shutoff
SlowStart
FimResistFR
Oil-ProhR
MedPresFR
No Cu/ PTFE FRL
Outdrs FR
F.R.L (Related)
CompFRL
LgFRL
PrecsR
VacF/R
Clean FR
ElecPneuR
AirBoost
SpdContr
Silncr
CheckV/ other
Jnt/tube
AirUnt
PrecsCompn
Mech/ ElecPresSw
ContactSW
AirSens
PresSW Cool
AirFloSens/ Contr
WaterRtSens
TotAirSys (Total Air)
TotAirSys (Gamma)
RefrDry
DesicDry
HiPolymDry
MainFiltr
Dischrg etc
Ending