

VIRIDIAN TECHNOLOGIES

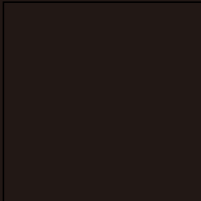

HAND DRYER
BABY CHANGING STATION
SOAP DISPENSER



HAND DRYER



VIRIDIAN TECHNOLOGIES



Wash+Dry Tap Hand Dryer

S1

Wash+Dry Tap Hand Dryer



- Combines an automatic tap and hand dryer so you can wash and dry your hands at the basin, made from high grade, solid Brass.
- The 2 sheets of air are used to wipe the water from your hands into the sink. No dripping on the floor. No extra floor space needed for hand drying and washing.
- Eco-efficient high speed hand drying in it's most simple and elegant format.
- Fitted with an anti bacterial HEPA filter to ensure the air used to dry users hands is as clean and hygienic as possible.
- The Air Tap is a space saving alternative to traditional hand dryer designs, using space over the basin that is otherwise overlooked. This saves valuable wall space, allowing you the opportunity to use this area for other items.

- Allowing over basin drying helps to minimise washroom clean up, and prevent slips as it eliminates water spillage on floors.
- Great for washroom areas with little wall space, the Air Tap hand dryer is simple but elegant and attaches straight to the basin.
- A brushless, carbon free motor offer it a super long service life reach to 7-10 years.
- Making use of no touch technology offers a more hygienic hand drying solution.
- Low noise with smart air outlet design - The airflow direction and speed has been carefully configured to ensure that there is no excess splashing or spray created and therefore works with a huge range of sinks.

VIRIDIAN TECHNOLOGIES

Body Material	Hpb59-1 Solid Brass
Voltage	220-240V
Frequency	50/60Hz
Total Power	800W
Motor Type	Digital brushless DC motor
RPM	60000
Electrical Isolation	Class II
Hot & Cold Switch	No
Current	3.5A
Air Speed	95m/s
Dimensions (mm) W x H x D	262x141x175
Filter	HEPA(13)
Air Temperature (10 cm distance/21°C)	33°C
Net Weight	5.8kgs
Noise Level In Db(at 2m)	75
Water Splash Proof	IP24
Auto Cutoff	30s

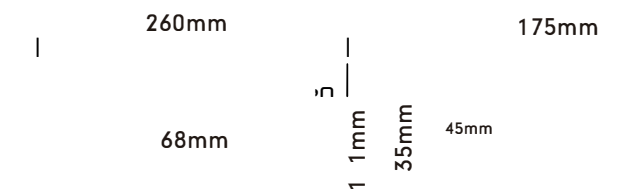

HAND DRYER



VIRIDIAN TECHNOLOGIES



Tap Hand Dryer

SD1

Tap Hand Dryer



- Made from high grade, solid Brass.
- Eco-efficient high speed hand drying in it's most simple and elegant format.
- Great for washroom areas with little wall space, the Air Tap hand dryer is simple but elegant and attaches straight to the basin.
- Allowing over basin drying helps to minimise washroom clean up, and prevent slips as it eliminates water spillage on floors.
- The Air Tap is a space saving alternative to traditional hand dryer designs, using space over the basin that is otherwise overlooked. This saves valuable wall space, allowing you the opportunity to use this area for other items.

- No mess and no water on the floor.
- Making use of no touch technology offers a more hygienic hand drying solution.
- Fitted with an anti bacterial HEPA filter to ensure the air used to dry users hands is as clean and hygienic as possible.
- A brushless, carbon free motor offer it a super long service life reach to 7-10 years.
- Low noise with smart air outlet design - The airflow direction and speed has been carefully configured to ensure that there is no excess splashing or spray created and therefore works with a huge range of sinks.

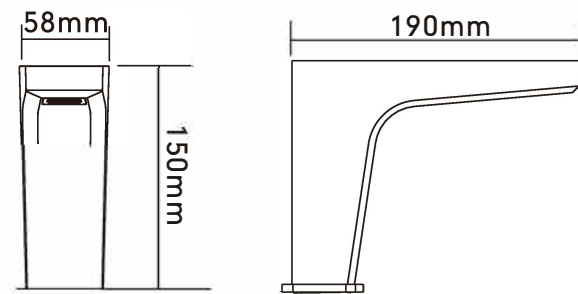

Body Material	Hpb59-1 Solid Brass
Voltage	220-240V
Frequency	50/60Hz
Total Power	500W
Motor Type	Digital brushless DC motor
RPM	45000
Electrical Lsolation	Class II
Hot & Cold Switch	No
Current	2.2A
Air Speed	90m/s
Dimensions (mm) W x H x D	260x250x200
Filter	HEPA(13)
Air Temperature (10 cm distance/21°C)	33°C
Net Weight	4.8kgs
Noise Level In Db(at 2m)	75
Water Splash Proof	IP24
Auto Cutoff	30s

SD2

Tap Hand Dryer



- Made from high grade, solid Brass.
- Eco-efficient high speed hand drying in it's most simple and elegant format.
- Great for washroom areas with little wall space, the Air Tap hand dryer is simple but elegant and attaches straight to the basin.
- A brushless, carbon free motor offer it a super long service life reach to 7-10 years.
- Low noise with smart air outlet design - The airflow direction and speed has been carefully configured to ensure that there is no excess splashing or spray created and therefore works with a huge range of sinks.
- Allowing over basin drying helps to minimise washroom clean up, and prevent slips as it eliminates water spillage on floors.

- No mess and no water on the floor.
- Making use of no touch technology offers a more hygienic hand drying solution.
- Fitted with an anti bacterial HEPA filter to ensure the air used to dry users hands is as clean and hygienic as possible.
- Easy to clean and simple to operate, featuring a stylish LED indicator.
- The Air Tap is a space saving alternative to traditional hand dryer designs, using space over the basin that is otherwise overlooked. This saves valuable wall space, allowing you the opportunity to use this area for other items.

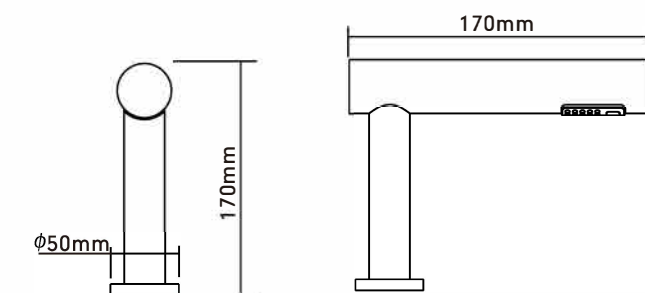

Body Material	Hpb59-1 Solid Brass
Voltage	220-240V
Frequency	50/60Hz
Total Power	500W
Motor Type	Digital brushless DC motor
RPM	50000
Electrical Lsolation	Class II
Hot & Cold Switch	No
Current	3.1A
Air Speed	90m/s
Dimensions (mm) W x H x D	58x150x190
Filter	HEPA(13)
Air Temperature (10 cm distance/21°C)	33°C
Net Weight	4.4kgs
Noise Level In Db(at 2m)	75
Water Splash Proof	IP24
Auto Cutoff	30s

VIRIDIAN TECHNOLOGIES



New Arrival
Jet hand dryer



Silver



White

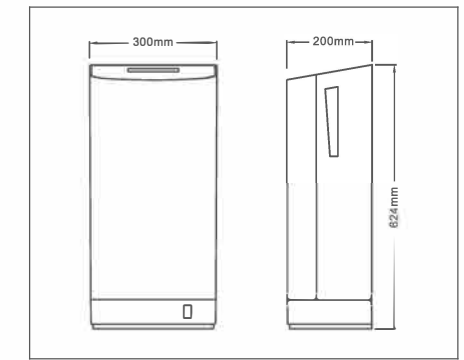

DC brushless motor	Commutator motor
Contact-free rotor eliminate wear and tear	Wear generated on brushes and rotor

Compact	1000 uses daily service life Approx. 7 years
---------	--

Time and energy saving	Time and energy saving Drying time Approx 5~7sec. Air speed 95m/s
------------------------	---

Standard voltage:	AC 220-240V/110V
Rated power:	800W-1650 W
Drying time:	5-7 Seconds
Air speed:	95 M/s
Noise Level:	72dB
Water proof:	IPX4
Air filter:	HEPA filter
Certification:	CE, RoHs, GS

VIRIDIAN TECHNOLOGIES

- The outer casing is made from an impact resistant, flameresistant ABS plastic with antimicrobial coating.
 - An intelligent heating system will detect the ambient temperature of your washroom, automatically adjust the airflow temperature to keep running costs right down. Automatically adds heat to the airflow if it senses a room temperature drop below 25°C.
 - It has a 2-level filter protection system , a pre-filter and a HEPA filter capture airborne bacteria to ensure your users hands are dried using clean, hygienic air particles.
 - Using the heated model on the high powered option provides incredible drying times of between 9 and 11 seconds.
 - The modern design and futuristic LED lighting make this a very popular addition to the most contemporary of washrooms.
 - A water collection system (800ml) collects any excess water to keep your washroom clean, tidy and safe.
 - HEPA filter is sterilised from microbes, bacteria and moulds by internal UVC technology, prolonging its effectiveness and preserving its cleanliness.
- Model A :** Powered by a brushless, carbon free motor means there are fewer parts to wear out, replace or break, meaning this hand dryer motor has a long life reach to 7-10 years.
- Model B :** Powered by a high speed reliable carbon brush motor .

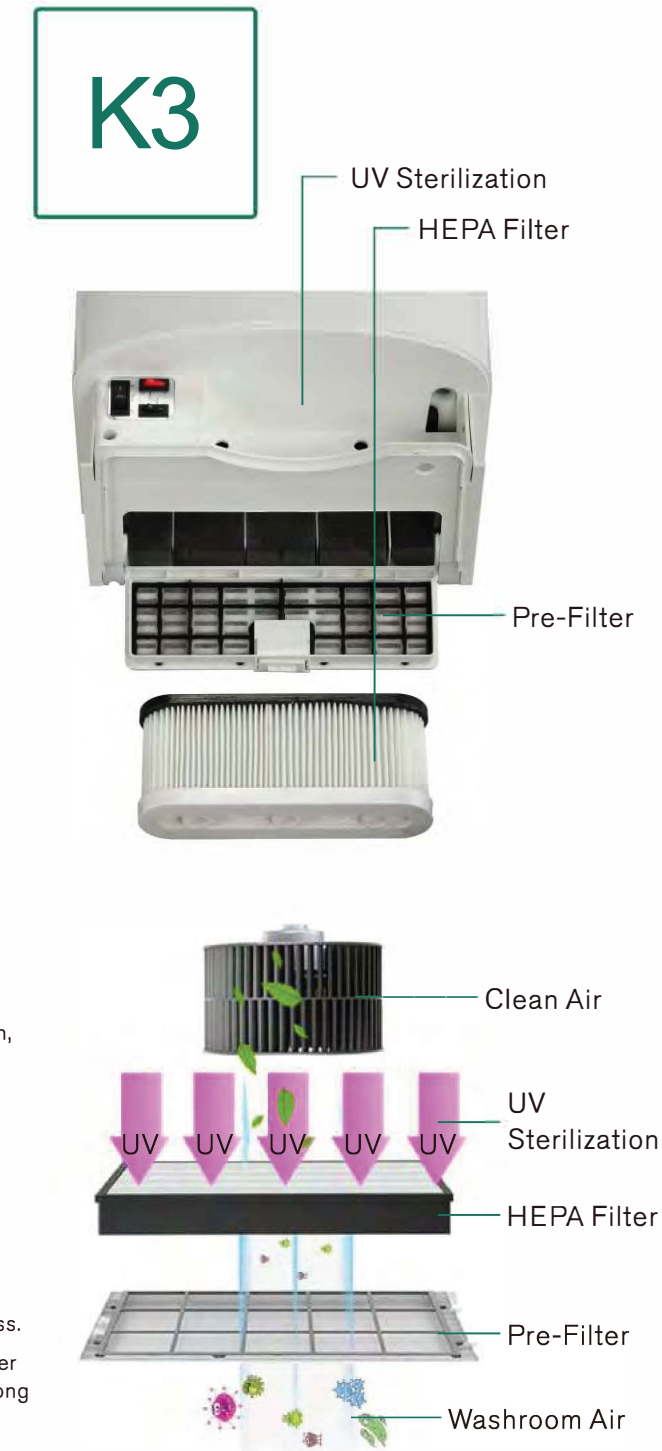



VIRIDIAN TECHNOLOGIES



Stainless steel
Jet hand dryer



VIRIDIAN TECHNOLOGIES

Compact 1000 uses daily service life Approx. 7 years	Wider and deeper 95mm 230mm
Time and energy saving Time and energy saving Drying time Approx 5-7sec. Air speed 95m/s	sensing start and stop
DC brushless motor Contact-free rotor eliminate wear and tear	Commutator motor Wear generated on brushes and rotor

K7

- A slimline, ultra-modern design and tough stainless steel case to protect against corrosion and vandalism.
- An intelligent heating system will detect the ambient temperature of your washroom, automatically adjust the airflow temperature to keep running costs right down. Automatically adds heat to the airflow if it senses a room temperature drop below 25°C.
- A water collection system (800ml) collects any excess water to keep your washroom clean, tidy and safe.
- Using the heated model on the high powered option provides incredible drying times of between 9 and 11 seconds.
- It has a smooth sound output and is engineered to minimise noise transfer from one area to another.
- The modern design and futuristic LED lighting make this a very popular addition to the most contemporary of washrooms.
- As an optional extra a HEPA Filter can be purchased and installed to captures airborne bacteria.

Model A : Powered by a brushless, carbon free motor means there are fewer parts to wear out, replace or break, meaning this hand dryer motor has a long life reach to 7-10 years.

Model B : Powered by a high speed reliable carbon brush motor .

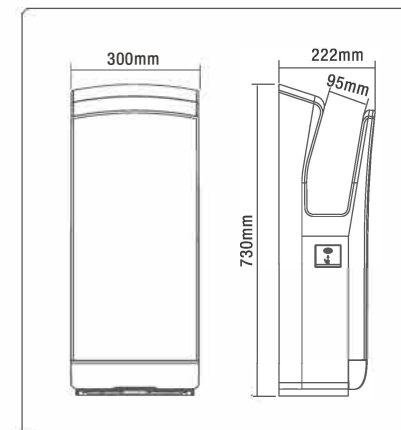

Name	Code	Voltage	Air speed	Drying time	Motor	Safe protection	Power	N.W.
Double jet hand dryer	K7	AC220-240V/ AC110V-127V 50/60Hz	95m/s	5-7s	DC brushless motor	Ex-high temperature Ex-long time Super-high current	800W 800W+850W Heater	12.5kg
Waterproof	IPX4	Product size	300X222X730(mm)		Packing size	80.5x38x59.5CM(2pcs)		



VIRIDIAN TECHNOLOGIES



Deep Silver



Silver

K2201



White



Black

Compact

1000 uses daily
service life
Approx. 7 years

Sensing start and stop

Time and energy saving

Drying time
Approx 5~7sec.
Air speed 95m/s

DC brushless motor

Contact-free rotor eliminate wear and tear

Commutator motor

Wear generated on brushes and rotor

- The outer casing is made from an impact resistant, flame resistant ABS plastic with antimicrobial coating.
- An intelligent heating system will detect the ambient temperature of your washroom, automatically adjust the airflow temperature to keep running costs right down. Automatically adds heat to the airflow if it senses a room temperature drop below 25°C.
- An LED display helps deliver the perfect dry by instructing the user on how fast to draw the hands through the airflow.
- A water collection system (800ml) collects any excess water to keep your washroom clean, tidy and safe.
- Using the heated model on the high powered option provides incredible drying times of between 9 and 11 seconds.
- It has a smooth sound output and is engineered to minimise noise transfer from one area to another.
- The modern design and futuristic LED lighting make this a very popular addition to the most contemporary of washrooms.
- As an optional extra a HEPA Filter can be purchased and installed to captures airborne bacteria.

Model A : Powered by a brushless, carbon free motor means there are fewer parts to wear out, replace or break, meaning this hand dryer motor has a long life reach to 7-10 years.

Model B : Powered by a high speed reliable carbon brush motor .

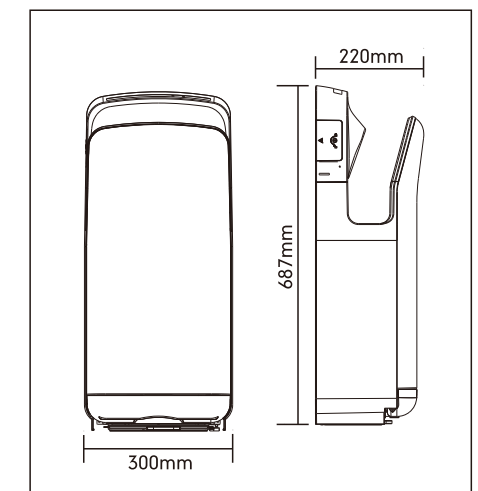

Name	Code	Voltage	Air speed	Drying time	Motor	Safe protection	Power	N.W.
Double jet hand dryer	K2201	AC220-240V/ AC110V-127V 50/60Hz	95m/s	5-7s	DC brushless motor	Ex-high temperature Ex-long time Super-high current	800W 800W+850W Heater	9.5kg
Waterproof	IPX4	Product size	300X220X687(mm)		Packing size	75x38x59CM(2pcs)		



<p>Wider and deeper</p>	<p>DC brushless motor</p> <p>Contact-free rotor eliminate wear and tear</p>	<p>Commutator motor</p> <p>Wear generated on brushes and rotor</p>		<div style="border: 2px solid green; padding: 10px; display: inline-block;"> <h1 style="margin: 0;">K2</h1> </div>
<p>Compact</p> <p>1000 uses daily service life Approx. 7 years</p>	<p>Time and energy saving</p> <p>Time and energy saving Drying time Approx 5~7sec. Air speed 95m/s</p>			

TECHNOLOGIES

Name	Double jet hand dryer	Safe protection	Ex-high temperature Ex-long time Super-high current
Code	K2	Power	800W+850W Heater
Voltage	AC220-240V/AC110V-127V , 50/60Hz	N.W.	9.5kg
Air speed	95m/s	Waterproof	IPX4
Drying time	5-7s	Product size	300x220x687mm
Motor	DC brushless motor	Packing size	75x38x59CM(2pcs)

- The outer casing is made from an impact resistant, flame resistant ABS plastic with antimicrobial coating.
- An intelligent heating system will detect the ambient temperature of your washroom, automatically adjust the airflow temperature to keep running costs right down. Automatically adds heat to the airflow if it senses a room temperature drop below 25°C.
- An LED display helps deliver the perfect dry by instructing the user on how fast to draw the hands through the airflow.
- A water collection system (800ml) collects any excess water to keep your washroom clean, tidy and safe.
- Using the heated model on the high powered option provides incredible drying times of between 9 and 11 seconds.
- It has a smooth sound output and is engineered to minimise noise transfer from one area to another.
- The modern design and futuristic LED lighting make this a very popular addition to the most contemporary of washrooms.
- As an optional extra a HEPA Filter can be purchased and installed to captures airborne bacteria.

Model A: Powered by a brushless, carbon free motor means there are fewer parts to wear out, replace or break, meaning this hand dryer motor has a long life reach to 7-10 years.

Model B: Powered by a high speed reliable carbon brush motor .

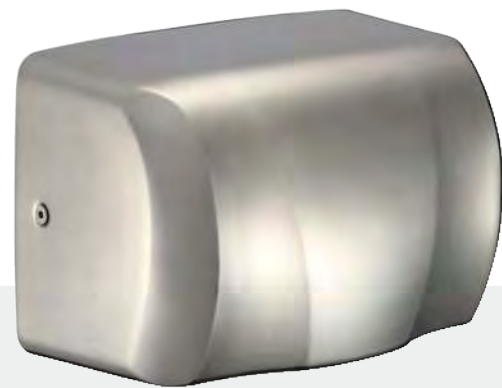

Stainless steel 304 brushed

K2019

Mini Horizontal

- The Mini powerful horizontal shape ensures the hand dryer can be sited in narrower, smaller bathrooms where wall space is limited.
- Equipped with advanced water-blasting technology, the upgraded motor delivers extremely impressive airflow speeds of up to 110 m/s.
- The hand dryer is fitted with an internal switch that can be altered from warm air using 950w or room temperature air using only 550w for energy savings during warmer months.
- Manufactured in grade 304 stainless steel 1.2mm thick to protect against corrosion and vandalism, it is a fully vandalproof dryer ideal for heavy duty areas.
- With a reduced noise level of 72 decibels, the hand dryer is perfectly suited to compact toilets where noise and the actual depth of the dryer must be reduced.
- Internal UVC technology 360° sterilize in the air.
- Fitted with an anti bacterial HEPA filter to ensure the air used to dry users hands is as clean and hygienic as possible.

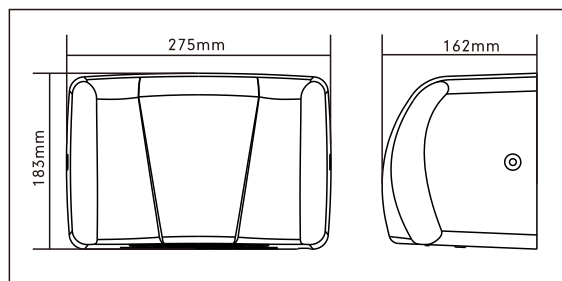
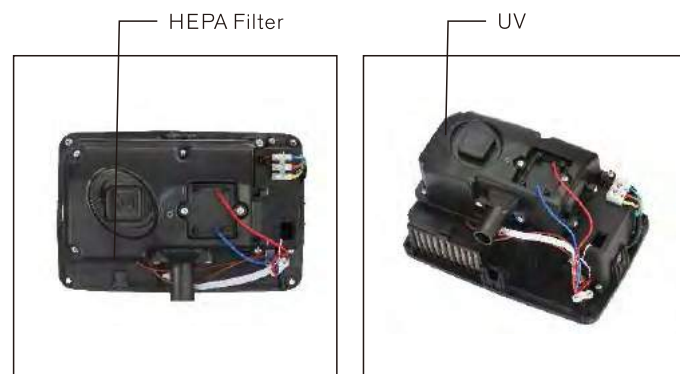
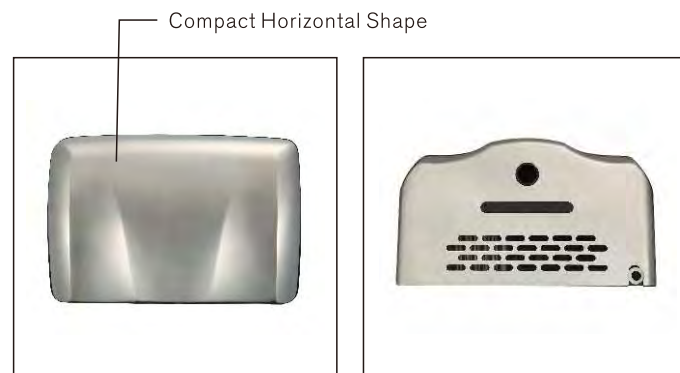

Body Material	SS 304	Current	8.0A
Mounting	Wall Mounted	Air Speed	110m/s
Voltage	220-240V	Dimensions (mm)	275Wx183Hx162D
Frequency	50/60Hz	Cover thickness	1.2mm
Total Power	1000W	Air temperature (10 cm distance/25°C)	50°C
Motor Power	500W	Net Weight	4.5kgs
RPM	30000	Noise Level In Db(at 2m)	75
Electrical Isolation	Class I	Water Splash Proof	IPX3
Hot & Cold Switch	Yes	Auto Cutoff	60s

K2020

Mini Vertical

- The Mini powerful vertical shape ensures the hand dryer can be sited in narrower, smaller bathrooms where wall space is limited.
- Equipped with advanced water-blasting technology, the upgraded motor delivers extremely impressive airflow speeds of up to 110 m/s.
- The hand dryer is fitted with an internal switch that can be altered from warm air using 950w or room temperature air using only 550w for energy savings during warmer months.
- Manufactured in grade 304 stainless steel 1.2mm thick to protect against corrosion and vandalism, it is a fully vandalproof dryer ideal for heavy duty areas.
- Fitted with advanced sensors with a stylish blue LED light for washrooms which consequently provides a visible indication of operation and the drying zone ensuring that the users hand's are always in the warm air stream.
- Internal UVC technology 360° sterilize in the air.
- Fitted with an anti bacterial HEPA filter to ensure the air used to dry users hands is as clean and hygienic as possible.



Stainless steel 304 brushed

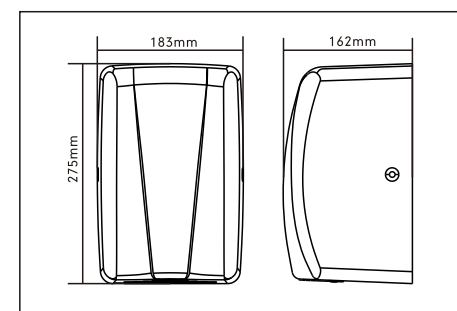
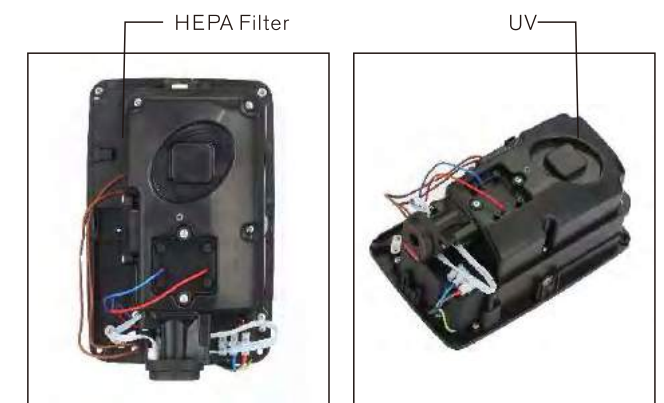
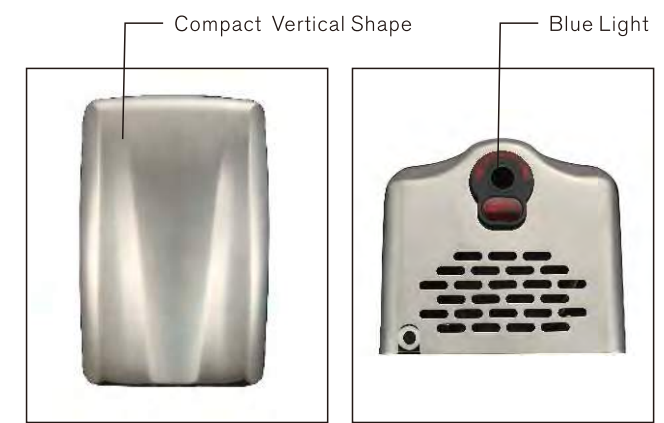

Body Material	SS 304	Current	8.0A
Mounting	Wall Mounted	Air Speed	110m/s
Voltage	220-240V	Dimensions (mm)	183Wx275Hx162D
Frequency	50/60Hz	Cover thickness	1.2mm
Total Power	1000W	Air temperature (10 cm distance/25°C)	50°C
Motor Power	500W	Net Weight	4.5kgs
RPM	30000	Noise Level In Db(at 2m)	75
Electrical Isolation	Class I	Water Splash Proof	IPX3
Hot & Cold Switch	Yes	Auto Cutoff	60s

VIRIDIAN TECHNOLOGIES



Brushless Slim Hand Dryer



Stainless steel 304 brushed

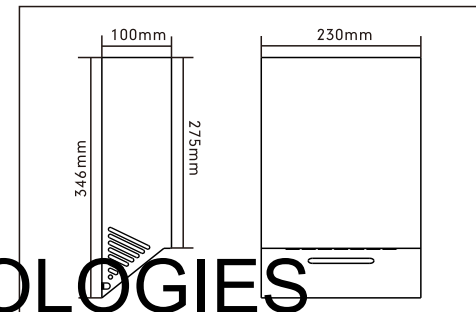

T1A

VIRIDIAN TECHNOLOGIES

Body Material	SS 304	Current	3.5A
Mounting	Wall Mounted	Air Speed	100m/s
Voltage	220-240V	Dimensions (mm)	230Wx346Hx100D
Frequency	50/60Hz	Cover thickness	1.5mm
Total Power	350-800W	Air temperature (10 cm distance/25°C)	38°C
Motor Power	350W	Net Weight	4.5kgs
RPM	50000	Noise Level In Db(at 2m)	79
Electrical Isolation	Class I	Water Splash Proof	IPX4
Hot & Cold Switch	Yes	Auto Cutoff	60s

- With an ultra slim design, the chassis measures just 100mm deep, making it ideal for a wide range of environments in all kinds of applications.
- Equipped with advanced water-blasting technology, ultra high speed motor delivers extremely impressive airflow speeds of up to 120 m/s.
- A brushless, carbon free motor offer it a super long service life reach to 7-10 years.
- Internal UVC technology 360° sterilize in the air even filtered by HEPA filter.
- Manufactured in grade 304 stainless steel 1.5mm thick to protect against corrosion and vandalism, it is a fully vandalproof dryer ideal for heavy duty areas.
- Built-in outstanding doubled HEPA filter for improved hygiene, it will stop any airborne germs or bacteria from entering the dryers.
- Only 800W power energy efficiency and down to surprising 350W if close the heater, costs up to 95% less to run than other hand dryers.

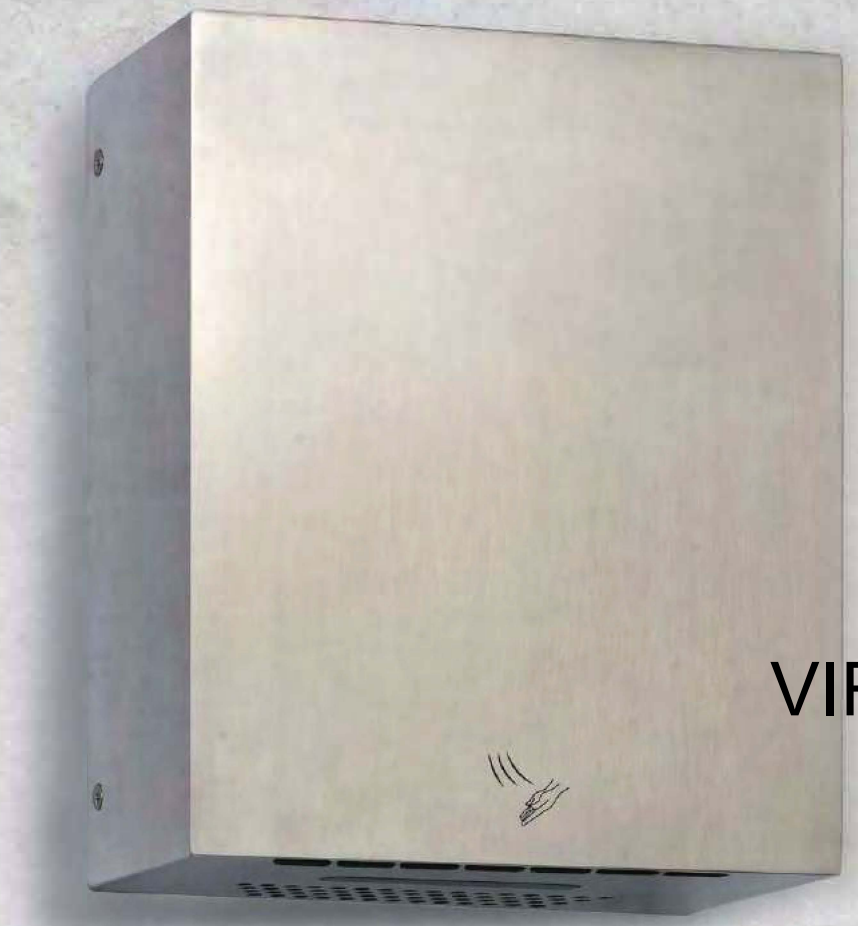

VIRIDIAN TECHNOLOGIES

Brushless Slim Hand Dryer

T1D

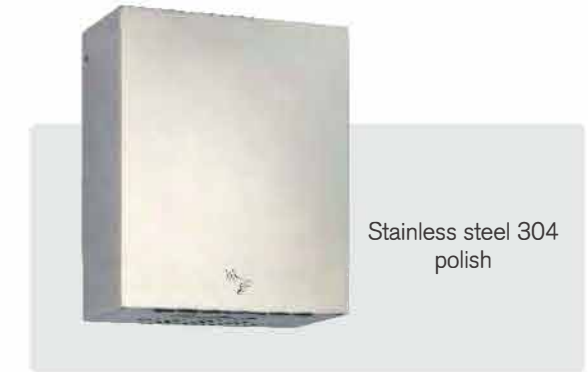
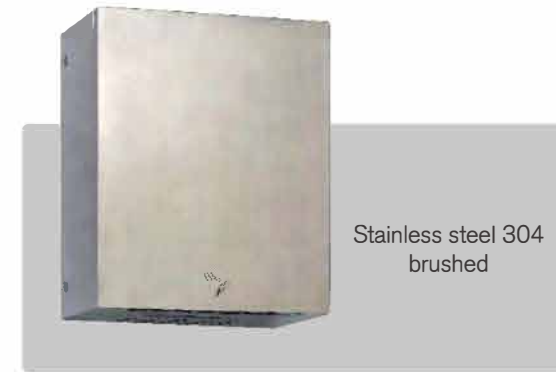

- With an ultra slim design, the chassis measures just 100mm deep, making it ideal for a wide range of environments in all kinds of applications.
- Manufactured in grade 304 stainless steel 1.5mm thick to protect against corrosion and vandalism, it is a fully vandalproof dryer ideal for heavy duty areas.
- Internal UVC technology 360° sterilize in the air even filtered by HEPA filter.
- Equipped with advanced water-blasting technology, ultra high speed motor delivers extremely impressive airflow speeds of up to 120 m/s.

- Only 800W power energy efficiency and down to surprising 350W if close the heater, costs up to 95% less to run than other hand dryers.
- Built-in improved doubled HEPA filter for improved hygiene, it will stop any airborne germs or bacteria from entering the dryers.
- A brushless, carbon free motor offer it a super long service life reach to 7-10 years.
- Snit for behind the mirror.

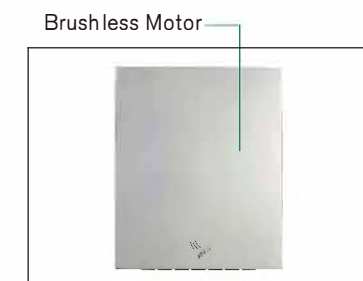
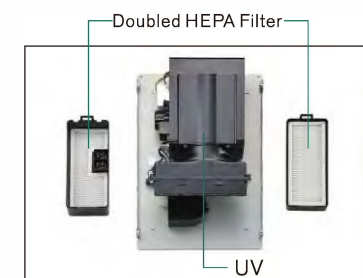
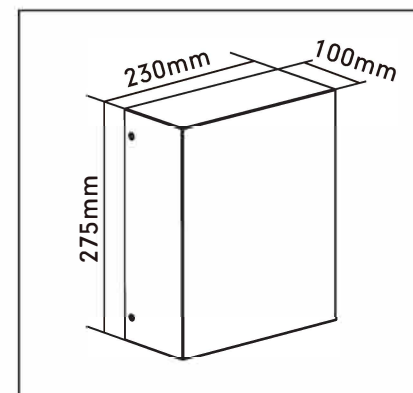

Body Material	S.S 304	Current	3.5A
Mounting	Wall Mounted	Air Speed	100m/s
Voltage	220-240V	Dimensions (mm)	230Wx275Hx100D
Frequency	50/60Hz	Cover thickness	1.5mm
Total Power	350-800W	Air temperature (10 cm distance/25°C)	38°C
Motor Power	350W	Net Weight	4.5kgs
RPM	50000	Noise Level In Db(at 2m)	79
Electrical Isolation	Class I	Water Splash Proof	IPX3
Hot & Cold Switch	Yes	Auto Cutoff	60s



Brushless Slim Hand Dryer

T2



- With an ultra slim design, the chassis measures just 100mm deep, making it ideal for a wide range of environments in all kinds of applications.
- Manufactured in grade 304 stainless steel 1.5mm thick to protect against corrosion and vandalism, it is a fully vandalproof dryer ideal for heavy duty areas.
- Equipped with advanced water-blasting technology, ultra high speed motor delivers extremely impressive airflow speeds of up to 100 m/s.
- Only 800W power energy efficiency and down to surprising 350W if close the heater, costs up to 95% less to run than other hand dryers.
- Built-in improved doubled HEPA filter for improved hygiene, it will stop any airborne germs or bacteria from entering the dryers.
- A brushless, carbon free motor offer it a super long service life reach to 7-10 years.
- Internal UVC technology 360° sterilize in the air even filtered by HEPA filter.

VIRIDIAN TECHNOLOGIES

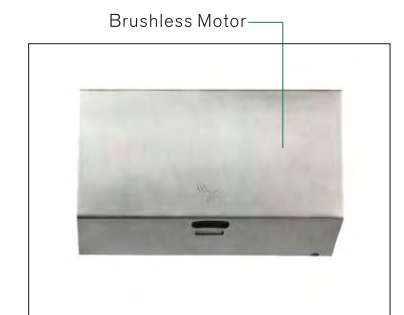
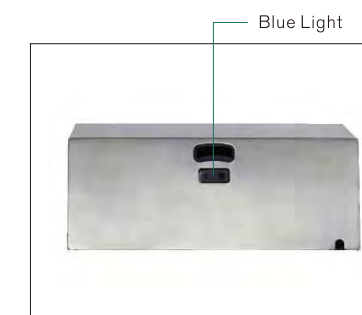
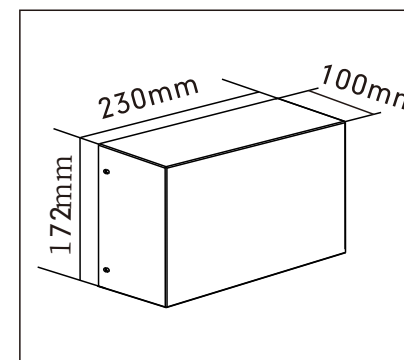

Body Material	S.S 304	Current	3.5A
Mounting	Wall Mounted	Air Speed	100m/s
Voltage	220-240V	Dimensions (mm)	230Wx172Hx100D
Frequency	50/60Hz	Cover thickness	1.5mm
Total Power	350-800W	Air temperature (10 cm distance/25°C)	38°C
Motor Power	350W	Net Weight	4.5kgs
RPM	50000	Noise Level In Db(at 2m)	79
Electrical Isolation	Class I	Water Splash Proof	IPX3
Hot & Cold Switch	Yes	Auto Cutoff	60s

New Arrival

HAND DRYER



VIRIDIAN TECHNOLOGIES

Classic high speed
hand dryer



VIRIDIAN TECHNOLOGIES

MODERN



Stainless steel 304 brushed



Stainless steel Black
(spray paint)



Stainless steel white
(spray paint)



Stainless steel 304 polish

K2008

- It has a market leading original clean and hygienic design. Together with a slim profile from the wall and only 75db noise level. Whilst drying hands in 7 to 10 seconds, makes this one of the class leading hand dryers in the World.
- Equipped with advanced water-blasting technology, the upgraded motor delivers extremely impressive airflow speeds of up to 100 m/s.
- The high speed motor has been built for longevity and is ideally suited to busy, high traffic washroom areas. Manufactured from high quality, top grade steel so you can feel confident that this hand dryer will stand up to the rigours of the job both internally and externally.
- Super smart, its ECO Air Sensor will detect the ambient temperature of your washroom, then automatically adjust the airflow temperature to keep running costs right down.

Time and energy saving

Time and energy saving
Drying time
Approx 7~10sec.
Air speed 100m/s

With metal cover

Stainless steel
304 panel
with thickness
of 1.2mm

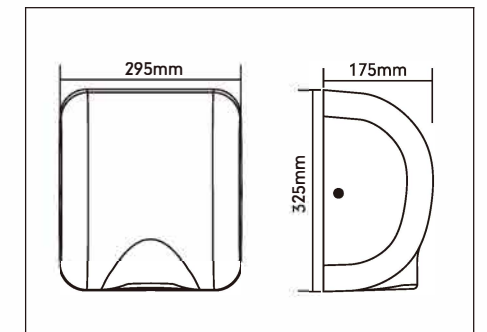

Name	Metal high speed hand dryer	Air temperature	40-65OC
Code	K2008	Time protect	60S
Voltage	AC220-240V/110-127V	Ambient humidity	80%
Frequency	50/60Hz	Ambient temperature	0-40OC
Rated power	1800W	Motor power	550W
Air speed	100m/S	Installation	Wall-mounted
Drying time	7-10S	N.W.	4.5kg
Sensing distance	12±3cm	Product size	295x175x325
Waterproof	IPX1	Packing size	71.5x38x45.5cm(4pcs)
Protection class	I	Standard	IEC60335-2-23
Storage	clean indoor		



VIRIDIAN TECHNOLOGIES

ANTI-VANDAL

Name	Code	Voltage	Air speed	Drying time	Motor	Safe protection	Power	N.W.
Metal high speed hand dryer	K2009	AC220-240V/ AC110V-127V, 50/60Hz	100m/s	7-10s	carbon brush	Ex-high temperature Ex-long time Super-high current	1800W	5.4kg



Stainless steel white
(spray paint)



Stainless steel 304
brushed



Stainless steel Black
(spray paint)

K2009A

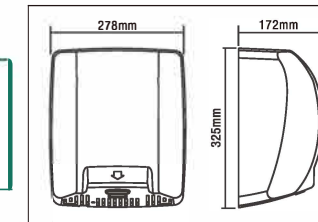

LED Indicator

K2009B

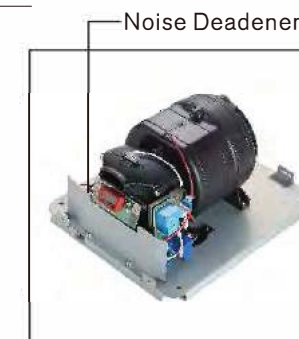
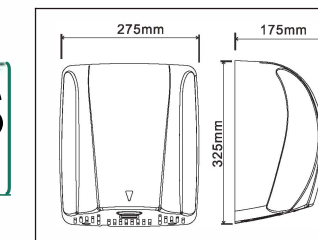

Noise Deadener

Blue Light



Stainless steel white
(spray paint)



Stainless steel 304
brushed



Stainless steel Black
(spray paint)

- Equipped with advanced water-blasting technology, the upgraded motor delivers extremely impressive airflow speeds of up to 100 m/s.
- Super smart, its Eco Air Sensor will detect the ambient temperature of your washroom, then automatically adjust the airflow temperature to keep running costs right down.
- Its contemporary, sleek, ergonomic design makes this an exceptionally stylish dryer.

- Manufactured in grade 304 stainless steel 1.5mm thick to protect against corrosion and vandalism, it is a fully vandalproof dryer ideal for heavy duty areas.
- Fitted with advanced sensors with a stylish blue LED light for washrooms and red, green front indicator light which consequently provides a visible indication of operation and the drying zone ensuring that the users hand's are always in the warm air stream.



K2010

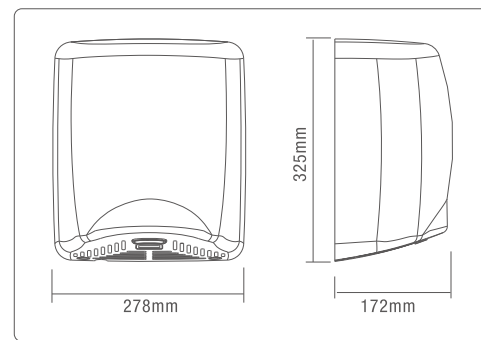
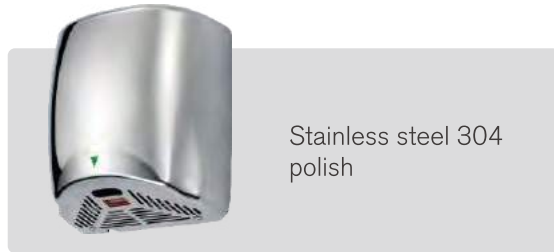

- Equipped with advanced water-blasting technology, the upgraded motor delivers extremely impressive airflow speeds of up to 100 m/s.
- Super smart, its Eco Air Sensor will detect the ambient temperature of your washroom, then automatically adjust the airflow temperature to keep running costs right down.
- Its contemporary, sleek, ergonomic design makes this an exceptionally stylish dryer.
- Manufactured in grade 304 stainless steel 1.5mm thick to protect against corrosion and vandalism, it is a fully vandalproof dryer ideal for heavy duty areas.
- Fitted with advanced sensors with a stylish blue LED light for washrooms and red, green front indicator light which consequently provides a visible indication of operation and the drying zone ensuring that the users hand's are always in the warm air stream.

Name	Metal high speed hand dryer	Safe protection	Ex-high temperature Ex-long time Super-high current
Code	K2010	Power	1800W
Voltage	AC220-240V/AC110V-127V ,50/60Hz	N.W.	5.4kg
Air speed	100m/s	Product size	278X172X325(mm)
Drying time	7-10s	Packing size	64x38x44.5CM
Motor	carbon brush		

K2011

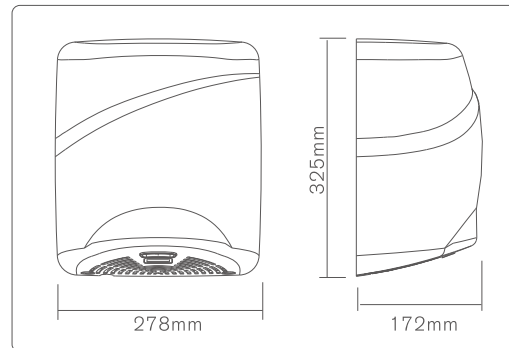

- Equipped with advanced water-blasting technology, the upgraded motor delivers extremely impressive airflow speeds of up to 100 m/s.
- Super smart, its Eco Air Sensor will detect the ambient temperature of your washroom, then automatically adjust the airflow temperature to keep running costs right down.
- Its contemporary, sleek, ergonomic design makes this an exceptionally stylish dryer.
- Manufactured in grade 304 stainless steel 1.5mm thick to protect against corrosion and vandalism, it is a fully vandalproof dryer ideal for heavy duty areas.
- Fitted with advanced sensors with a stylish blue LED light for washrooms and red, green front indicator light which consequently provides a visible indication of operation and the drying zone ensuring that the users hand's are always in the warm air stream.

Name	Metal high speed hand dryer	Safe protection	Ex-high temperature Ex-long time Super-high current
Code	K2010	Power	1800W
Voltage	AC220-240V/AC110V-127V ,50/60Hz	N.W.	5.4kg
Air speed	100m/s	Product size	278X172X325(mm)
Drying time	7-10s	Packing size	64x38x44.5CM
Motor	carbon brush		

VIRIDIAN TECHNOLOGIES



COMPACT

VRIDIAN TECHNOLOGIES

- The compact powerful shape ensures the hand dryer can be sited in narrower, smaller bathrooms where wall space is limited.
- Equipped with advanced water-blasting technology, the upgraded motor delivers extremely impressive airflow speeds of up to 100 m/s.
- Super smart, its Eco Air Sensor will detect the ambient temperature of your washroom, then automatically adjust the airflow temperature to keep running costs right down.
- Manufactured in grade 304 stainless steel 1.5mm thick to protect against corrosion and vandalism, it is a fully vandalproof dryer ideal for heavy duty areas.
- Fitted with advanced sensors with a stylish blue LED light for washrooms which consequently provides a visible indication of operation and the drying zone ensuring that the users hand's are always in the warm air stream.

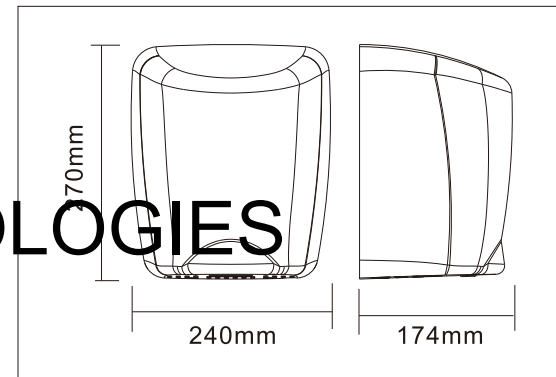

K2012



Time and energy saving
 Time and energy saving
 Drying time
 Approx 7~10sec.
 Air speed 100m/s

With metal cover
 Stainless steel
 304 panel
 with thickness
 of 1.5mm

Name	Metal high speed hand dryer	Water proof	IPX1
Code	K2012	Shell	Stainless steel 304
Voltage	220-240V/50Hz or 110-127V/60Hz	Rated Power	1800W
Air speed	100m/s	CTN G.W.:	4.2kg



Stainless steel 304
bright finish



Stainless steel 304
brushed finish



Stainless steel 304
gray



Stainless steel 304
white

ECO



HEPA system prevent bacterial and ensure clean air is drying the hands. Selectable 650W heating element (1250W) by hot/cool option and selectable strong/soft option.



With 190mm lengthened air outlet design, provide soft and fast wind to dry hands and arms

- Manufactured in grade 304 stainless steel to protect against corrosion and vandalism.
- It has a blade, rather than a tube of air, resulting in the amazingly economic performance and super fast drying time.
- Built-in removable air HEPA filter for improved hygiene, it will stop any airborne germs or bacteria from entering the dryers.
- Fitted with advanced sensors with a stylish blue LED light for washrooms which consequently provides a visible indication of operation and the drying zone ensuring that the users hand's are always in the warm air stream.
- Eco-friendly switchable power modes (down to 400W) ,With 4 settings to choose from, you can really customise this hand dryer based on your own unique requirements.
- Super easy installation The back cover on the dryer does not need removing for installation.

K2013A

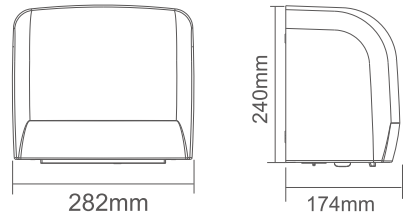

Bright finish

Brushed finish

Silver

White

Name	Metal high speed hand dryer	Water proof	IPX1
Code	K2013A	Shell	Stainless steel 304
Voltage	220-240V/50Hz 110-127V/60Hz	CTN Size	56.7x31x42.5cm (4pcs)
Air speed	105m/s	CTN G.W.:	20kg (4pcs)
Rated power	1250W		

K2013B

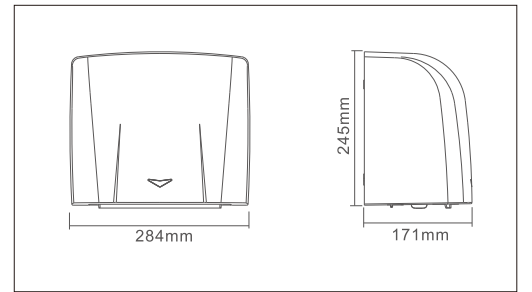

White



Silver



Black

K2013C

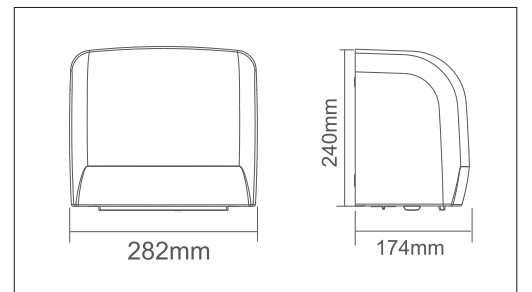

White



Silver



Black

Name	ABS high speed hand dryer	Water proof	IPX1
Code	K2013B/K2013C	Shell	ABS
Voltage	220-240V/50Hz 110-127V/60Hz	CTN Size	57x31.5x44cm (4pcs)
Air speed	105m/s	CTN G.W.:	16.4kg(4pcs)
Rated power	1250W		

VIRIDIAN TECHNOLOGIES



V Blade
High speed hand dryer

New Arrival



V BLADE

VIRIDIAN TECHNOLOGIES

K2015



Equipped with multiple filter and noise deadener



doubled air outlet with 12cm lengthened design

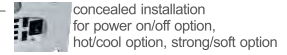

concealed installation for power on/off option, hot/cool option, strong/soft option

- Equipped with the latest twin Blade V-style technology. Two angled blades of air simultaneously scrape moisture from the hands providing a rapid and consistent dry which is not so easy to achieve from a single outlet.
- Smart eco-mode switching, letting you choose the ideal settings for your washroom. Simply set the internal switches to hot or cool – with soft or strong air flow.
- Super easy installation. The back cover on the dryer does not need removing for installation.
- With 4 settings to choose from, you can really customise this hand dryer based on your own unique requirements. This fast drying, yet quiet hand dryer can be set to a really energy efficient 600-800W by switching off its heater element, reducing energy usage.
- With a state-of-the-art 800W motor, it uses twin-blades in a V-formation, generating quick-drying sheets of air at over 100 m/s.
- Built-in removable air HEPA filter for improved hygiene, it will stop any airborne germs or bacteria from entering the dryers.

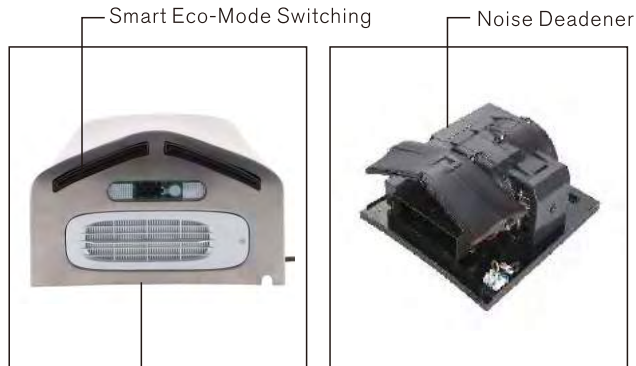

HEPA Filter

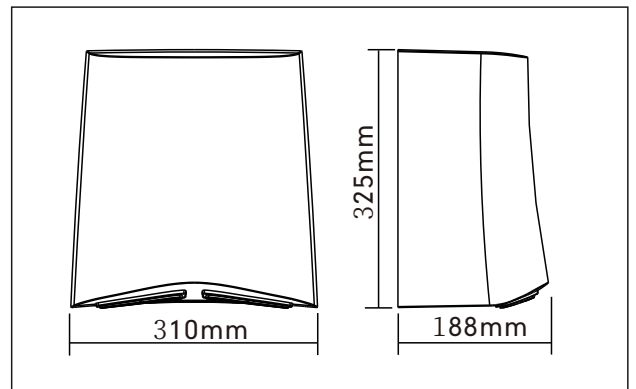

Body Material	S.S 304
Voltage	220-240V
Frequency	50/60Hz
Total Power	600-2000W
Motor Power	600-800W
RPM	24000
Electrical Isolation	Class I
Hot & Cold Switch	Yes
Current	5.5A
Air Speed	100m/s
Dimensions (mm) W x H x D	310x325x188
Cover thickness	1.2mm
Air Temperature (10 cm distance/21°C)	38°C
Net Weight	5.9kgs
Noise Level In Db(at 2m)	70
Water Splash Proof	IPX3
Auto Cutoff	60s

ULTRATHIN HAND DRYER

VIRIDIAN TECHNOLOGIES



Super-slimline
High Speed Hand Dryer

New Arrival



VIRIDIAN TECHNOLOGIES

ULTRATHIN

K2016

- it has the ability to be run at only 400W by switching off the internal heater, making this one of our most ecofriendly dryers.
- Manufactured in grade 304 stainless steel 1.5mm thick to protect against corrosion and vandalism.
- With an ultra slim design, the chassis measures just 100mm deep, making it ideal for a wide range of environments in all kinds of applications.
- With a reduced noise level of 75 decibels, the hand dryer is perfectly suited to compact toilets where noise and the actual depth of the dryer must be reduced.
- As an optional extra a HEPA Filter can be purchased and installed to captures airborne bacteria.
- Besides its great energy efficiency, the stainless steel case, secured by 4 security screws, prevents vandalism and ensures durability and It also has a solid steel backplate.

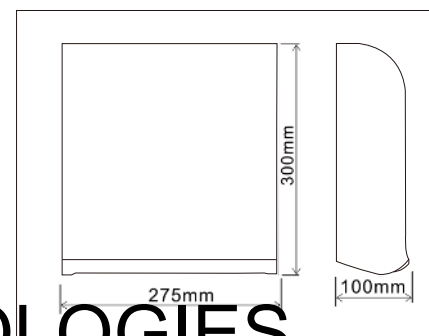
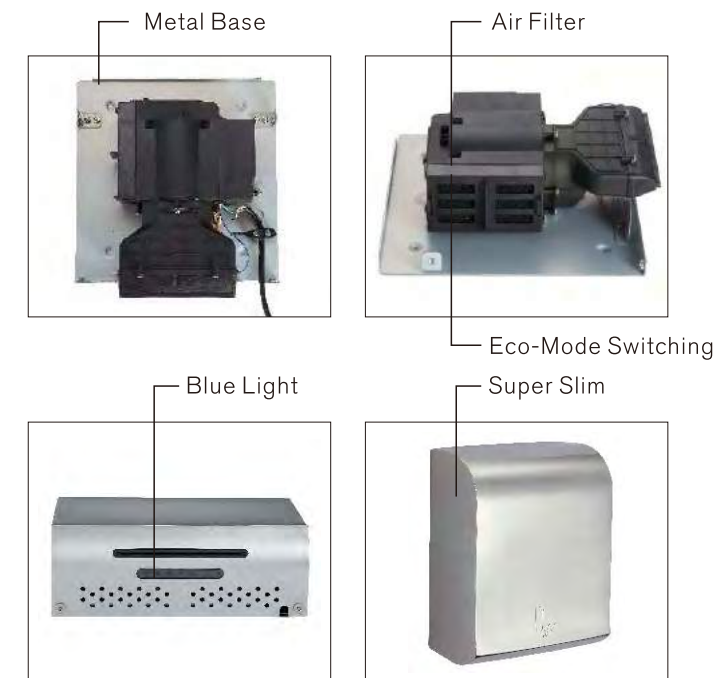

Stainless steel white (spray paint) Stainless steel 304 brushed Stainless steel 304 polish Stainless steel Black (spray paint)

Shell material	304 stainless steel	Operation	infrared automatic 'no touch'
Standard voltage	AC 220-240V/110V	Timing protection	Timing protection: 60 seconds auto cut off
Rated frequency	50/60 Hz	Thermal cut-out	Thermal cut-out: cut off above 70 C
Rated power	Variable: 400W-950 W (Switchable Heating Element)	Air filter	Yes
Drying time	7-12 Seconds	Certification	CE, RoHs, GS
Air speed	95 M/s	Package contents:	hand dryer, installation accessories and user manual
Noise Level	75dB	Carton size	64*38.5*28 cm (4pcs)
Water proof	IPX3		

New Arrival



VIRIDIAN TECHNOLOGIES

STYLISH



Stainless steel 304 brushed



Stainless steel 304 polish

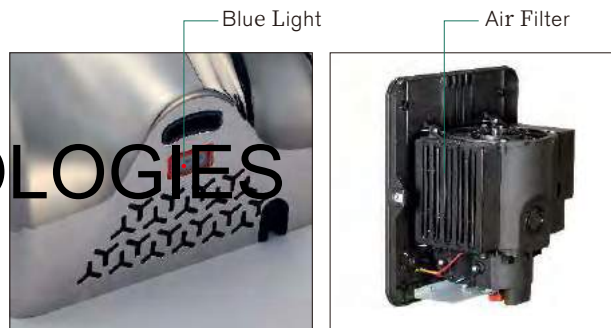

Blue Light

Air Filter

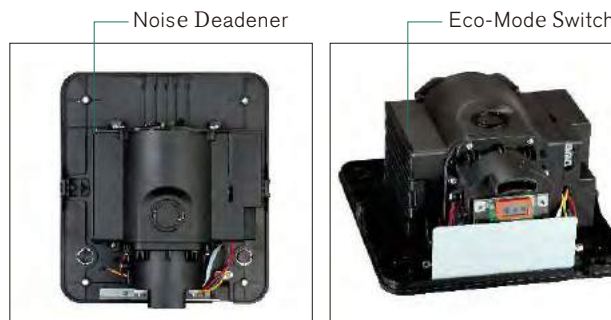

Noise Deadener

Eco-Mode Switching

K2017A

- Manufactured from robust grade 304 stainless steel with a one piece outer and vandal proof lock screws for easy installation and strong anti vandal properties.
- Equipped with advanced water-blasting technology, the upgraded motor delivers extremely impressive airflow speeds of up to 110 m/s.
- As an optional extra a HEPA Filter can be purchased and installed to captures airborne bacteria.
- Super smart, its ECO Air Sensor will detect the ambient temperature of your washroom, then automatically adjust the airflow temperature to keep running costs right down.
- It has the ability to be run at only 550W by switching off the internal heater, making this one of our most eco-friendly dryers.

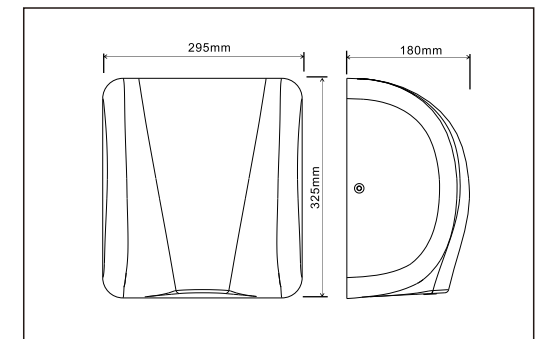

Shell material	304 stainless steel	Water proof	IPX3
Standard voltage	AC 220-240V/110V	Operation	infrared automatic 'no touch'
Rated frequency	50/60 Hz	Timing protection	60 seconds auto cut off
Rated power	Variable: 600W/1800 W (Switchable Heating Element)	Thermal cut-out	cut off above 95 C
Installation	Wall mounted	Air filter	Yes
Drying time	7-12 Seconds	Certification	CE, RoHs, GS,CB
Air speed	110m/s	Package contents	hand dryer, installation accessories and user manual
Noise Level	72dB	Carton size	70X41X47.5 cm (4pcs)



K2017B



Stainless steel 304 brushed



Stainless steel 304 polish

VIRIDIAN TECHNOLOGIES

- Manufactured from robust grade 304 stainless steel with a one piece outer and vandal proof lock screws for easy installation and strong anti vandal properties.
- Equipped with advanced water-blasting technology, the upgraded motor delivers extremely impressive airflow speeds of up to 115m/s.
- Super smart, its ECO Air Sensor will detect the ambient temperature of your washroom, then automatically adjust the airflow temperature to keep running costs right down.
- It has the ability to be run at only 550W by switching off the internal heater, making this one of our most eco-friendly dryers.
- Fitted with advanced sensors with a stylish blue LED light for washrooms and red, green front indicator light which consequently provides a visible indication of operation and the drying zone ensuring that the users hand's are always in the warm air stream.
- As an optional extra a HEPA Filter can be purchased and installed to captures airborne bacteria.

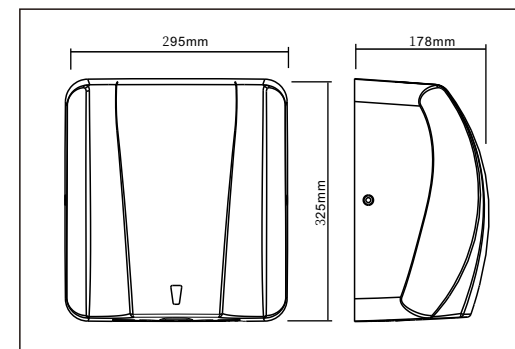

SMART



Shell material	304 stainless steel	Water proof	IPX3
Standard voltage	AC 220-240V/110V	Operation	infrared automatic 'no touch'
Rated frequency	50/60 Hz	Timing protection	60 seconds auto cut off
Rated power	Variable: 600W/1800 W (Switchable Heating Element)	Thermal cut-out	cut off above 95 C
Installation	Wall mounted	Air filter	Yes
Drying time	7-12 Seconds	Certification	CE, RoHs, GS,CB
Air speed	115m/s	Package contents	hand dryer, installation accessories and user manual
Noise Level	76dB	Carton size	70X41X47.5 cm (4pcs)

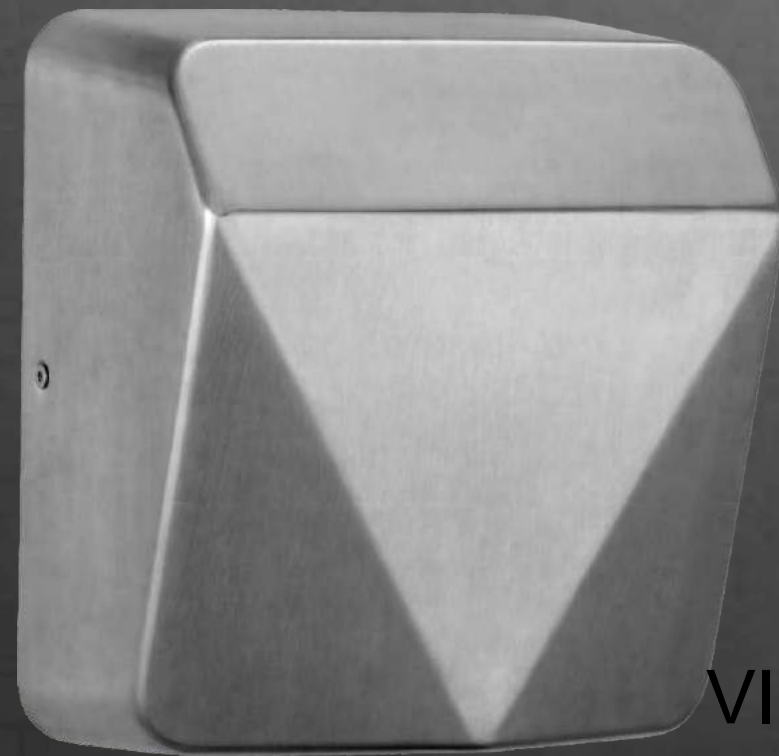

VIRIDIAN TECHNOLOGIES

NOVA

K2017C

- Inspired by the shape of diamond, manufactured in grade 304 stainless steel 1.5mm thick to protect against corrosion and vandalism, it is a fully vandalproof dryer ideal for heavy duty areas.
- Equipped with advanced water-blasting technology, the upgraded motor delivers extremely impressive airflow speeds of up to 115 m/s.
- As an optional extra a HEPA Filter can be purchased and installed to capture airborne bacteria.
- Super smart, its ECO Air Sensor will detect the ambient temperature of your washroom, then automatically adjust the airflow temperature to keep running costs right down.
- It has the ability to be run at only 550W by switching off the internal heater, making this one of our most eco-friendly dryers.



Stainless steel 304
polish



Stainless steel 304
brushed



Blue Light



Air Filter

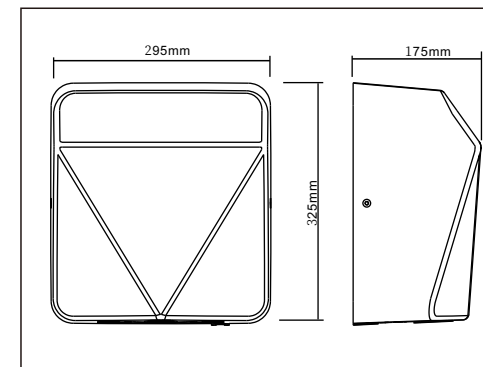

Noise Deadener

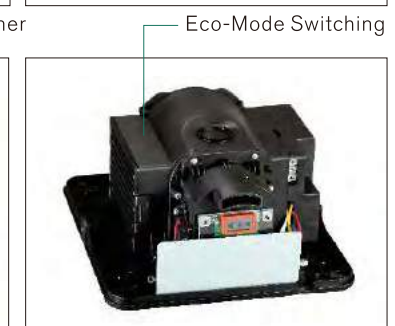

Eco-Mode Switching

Shell material	304 stainless steel	Water proof	IPX3
Standard voltage	AC 220-240V/110V	Operation	infrared automatic 'no touch'
Rated frequency	50/60 Hz	Timing protection	60 seconds auto cut off
Rated power	Variable: 600W/1800 W (Switchable Heating Element)	Thermal cut-out	cut off above 95 C
Installation	Wall mounted	Air filter	Yes
Drying time	7-12 Seconds	Certification	CE, RoHs, GS, CB
Air speed	115m/s	Package contents	hand dryer, installation accessories and user manual
Noise Level	76dB	Carton size	70X41X47.5 cm (4pcs)



RECESSED

K2018



VIRIDIAN TECHNOLOGIES

Brushless Motor



Only 62mm Exposed



HEPA Filter Inside



Ceramic Water Absorbent Surface



- Semi-recessed with only 62mm showing into the washroom.
- Powered by a brushless, carbon free motor means there are fewer parts to wear out, replace or break, meaning this hand dryer motor has a long life.
- Equipped with a 18cm deep alcove that captures and evaporates water thanks to a ceramic water absorbent surface.
- All welded corners secured to cabinet with vandalresistant screws.
- The built-in HEPA filter captures airborne bacteria to ensure your users hands are dried using clean, hygienic air particles.
- Air inlets on sides for better heat dissipation.

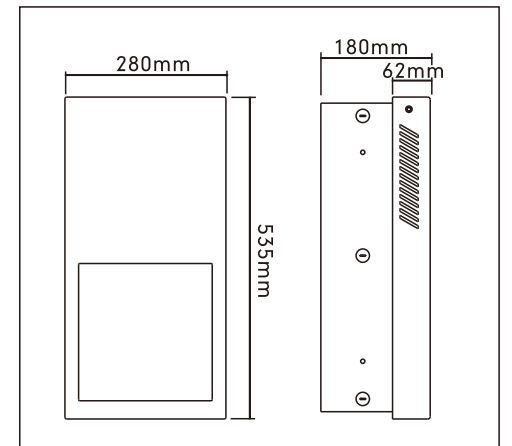

Shell material	304 stainless steel	Water proof	IPX3
Standard voltage	AC 220-240V/110V	Operation	infrared automatic 'no touch'
Rated frequency	50/60 Hz	Timing protection	60 seconds auto cut off
Rated power	1100 W	Thermal protection	cut off above 70 C
Installation	Wall recess mounted	Air filter	HEPA filter
Drying time	7-12 Seconds	Certification	CE, RoHs
Air speed	90 m/s	Package contents	hand dryer, installation accessories and user manual
Noise Level	75dB	Carton size	61*33*50.5 cm (2pcs)

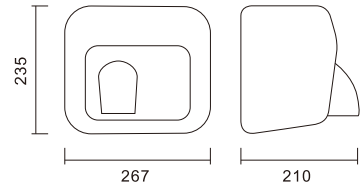

K2502A

SPECIFICATIONS:
 Voltage: 220-240V/50Hz or 110-127V/60Hz
 Rated power: 2300W
 Air speed: 25m/s
 Waterproof: IPX1
 Shell: Stainless steel 304(1.2mm)
 Surface: bright or brushed
 CTN Size: 56.5x31.5x54.5CM (4 pcs)
 CTN.G.W: 21.5kg

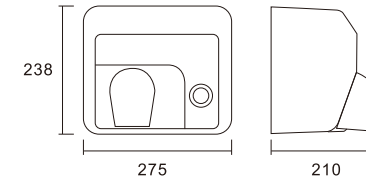

K2503A-K

SPECIFICATIONS:
 Voltage: 220-240V/50Hz or 110-127V/60Hz
 Rated power: 2300W
 Air speed: 25m/s
 Waterproof: IPX1
 Shell: Stainless steel 304(1.2mm)
 Surface: bright or brushed
 CTN Size: 57x32.5x54CM (4 pcs)
 CTN.G.W: 23kg

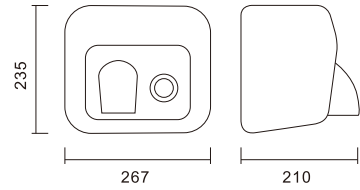

K2502A-K

SPECIFICATIONS:
 Voltage: 220-240V/50Hz or 110-127V/60Hz
 Rated power: 2300W
 Air speed: 25m/s
 Waterproof: IPX1
 Shell: Stainless steel 304(1.2mm)
 Surface: bright or brushed
 CTN Size: 56.5x31.5x54.5CM (4 pcs)
 CTN.G.W: 21.5kg

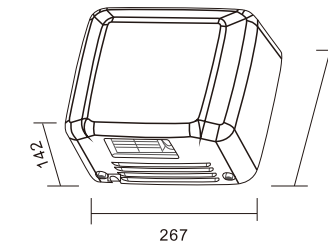

K2504

SPECIFICATIONS:
 Voltage: 220-240V/50Hz or 110-127V/60Hz
 Rated power: 2300W
 Air speed: 25m/s
 Waterproof: IPX1
 Shell: Stainless steel 304(1.2mm)
 Surface: bright or brushed
 CTN Size: 56.5x31.5x54.5CM (4 pcs)
 CTN.G.W: 21kg

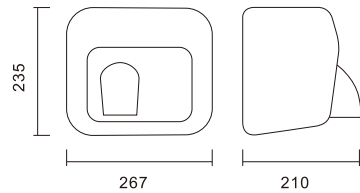

K2502 (ABS silver)

SPECIFICATIONS:
 Voltage: 220-240V/50Hz or 110-127V/60Hz
 Rated power: 2300W
 Air speed: 25m/s
 Waterproof: IPX1
 Shell: ABS
 Color: gray
 CTN Size: 62x56x53.5CM (8 pcs)
 CTN.G.W: 29kg

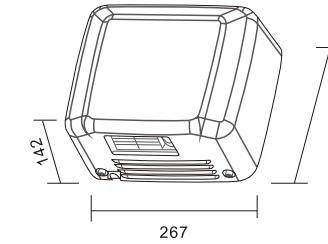

K2504 (ABS white)

SPECIFICATIONS:
 Voltage: 220-240V/50Hz or 110-127V/60Hz
 Rated power: 2300W
 Air speed: 25m/s
 Waterproof: IPX1
 Shell: ABS
 Color: white
 CTN Size: 62x56x53.5CM (8 pcs)
 CTN.G.W: 28kg

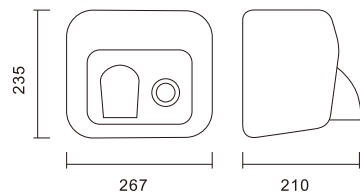

K2502 (ABS white)

SPECIFICATIONS:
 Voltage: 220-240V/50Hz or 110-127V/60Hz
 Rated power: 2300W
 Air speed: 25m/s
 Waterproof: IPX1
 Shell: ABS
 Color: white
 CTN Size: 62x56x53.5CM (8 pcs)
 CTN.G.W: 29kg

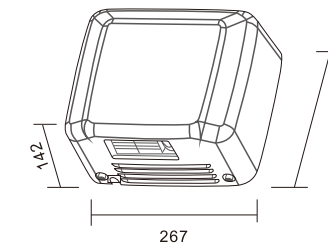

K2504 (ABS silver)

SPECIFICATIONS:
 Voltage: 220-240V/50Hz or 110-127V/60Hz
 Rated power: 2300W
 Air speed: 25m/s
 Waterproof: IPX1
 Shell: ABS
 Color: gray
 CTN Size: 62x56x53.5CM (8 pcs)
 CTN.G.W: 28kg

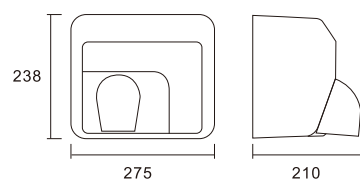

K2503A

SPECIFICATIONS:
 Voltage: 220-240V/50Hz or 110-127V/60Hz
 Rated power: 2300W
 Air speed: 25m/s
 Waterproof: IPX1
 Shell: Stainless steel 304(1.2mm)
 Surface: bright or brushed
 CTN Size: 57x32.5x54CM (4 pcs)
 CTN.G.W: 23kg

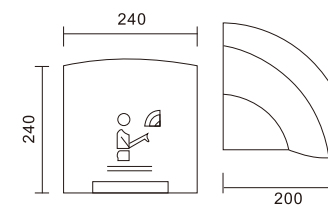

K1003

SPECIFICATIONS:
 Voltage: 220-240V/50Hz or 110-127V/60Hz
 Rated power: 1800W
 Air speed: 12m/s
 Waterproof: IPX1
 Shell: ABS
 Color: white
 CTN Size: 57.5x55x54CM (8 pcs)
 CTN.G.W: 21kg

VIRIDIAN TECHNOLOGIES

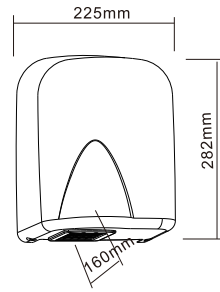

K1005A

SPECIFICATIONS:
 Voltage: 220-240V/50Hz or 110-127V/60Hz
 Rated power: 1500W
 Air speed: 12m/s
 Waterproof: IPX1
 Shell: stainless steel 304
 Surface: bright
 CTN Size: 49x36x63CM(8pcs)
 CTN.G.W: 27kg

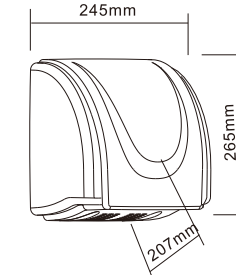

K2505A

SPECIFICATIONS:
 Voltage: 220-240V/50Hz or 110-127V/60Hz
 Rated power: 2300W
 Air speed: 25m/s
 Waterproof: IPX1
 Shell: Stainless steel 304
 Surface: bright
 CTN Size: 56.5x32.5x51CM (4 pcs)
 CTN.G.W: 20kg

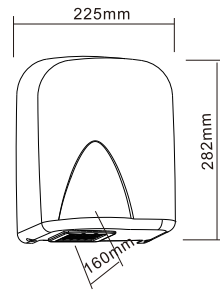

K1005E

SPECIFICATIONS:
 Voltage: 220-240V/50Hz or 110-127V/60Hz
 Rated power: 1500W
 Air speed: 12m/s
 Waterproof: IPX1
 Shell: ABS
 Color: white
 CTN Size: 49x36x63CM(8pcs)
 CTN.G.W: 23kg

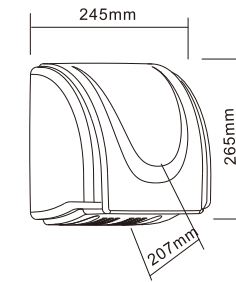

K2505E

SPECIFICATIONS:
 Voltage: 220-240V/50Hz or 110-127V/60Hz
 Rated power: 2300W
 Air speed: 25m/s
 Waterproof: IPX1
 Shell: ABS
 Surface: white
 CTN Size: 56.5x32.5x51CM (4 pcs)
 CTN.G.W: 15kg

VIRIDIAN TECHNOLOGIES

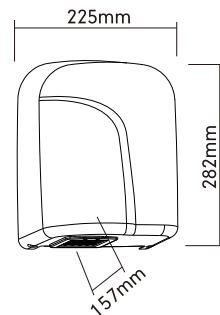

K1006A

SPECIFICATIONS:
 Voltage: 220-240V/50Hz or 110-127V/60Hz
 Rated power: 1500W
 Air speed: 12m/s
 Waterproof: IPX1
 Shell: stainless steel 304
 Surface: bright
 CTN Size: 49x36x63CM(8pcs)
 CTN.G.W: 27kg

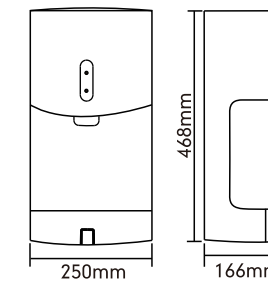

K2003

SPECIFICATIONS:
 Voltage: 220-240V/50Hz or 110-127V/60Hz
 Rated power: 2600W
 Air speed: 105m/s
 Waterproof: IPX1
 Shell: ABS
 Surface: white
 CTN Size: 61.5x52.5x43.5CM (4 pcs)
 CTN.G.W: 20kg

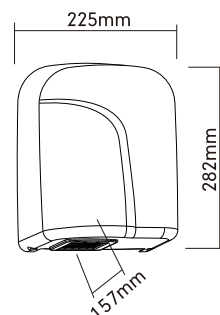

K1006E

SPECIFICATIONS:
 Voltage: 220-240V/50Hz or 110-127V/60Hz
 Rated power: 1500W
 Air speed: 12m/s
 Waterproof: IPX1
 Shell: ABS
 Color: white
 CTN Size: 49x36x63CM(8pcs)
 CTN.G.W: 23kg

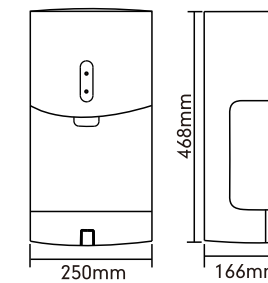

K2003

SPECIFICATIONS:
 Voltage: 220-240V/50Hz or 110-127V/60Hz
 Rated power: 2600W
 Air speed: 105m/s
 Waterproof: IPX1
 Shell: ABS
 Surface: silver
 CTN Size: 61.5x52.5x43.5CM (4 pcs)
 CTN.G.W: 20kg

HAND DRYER

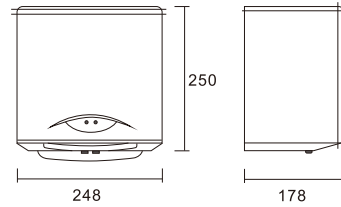

K2001 (white)

SPECIFICATIONS:
 Voltage: 220-240V/50Hz or 110-127V/60Hz
 Rated power: 1100W
 Air speed: 90m/s
 Waterproof: IPX1
 Shell: ABS
 Color: white
 CTN Size: 62x32x43.5CM (4 pcs)
 CTN.G.W: 17kg

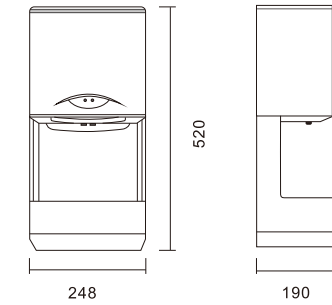

K2001-J1 (white)

SPECIFICATIONS:
 Voltage: 220-240V/50Hz or 110-127V/60Hz
 Rated power: 1100W
 Air speed: 90m/s
 Waterproof: IPX1
 Shell: ABS
 Color: white
 CTN Size: 61x42.5x46CM (4 pcs)
 CTN.G.W: 21.7kg

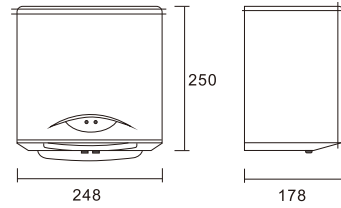

K2001 (silver)

SPECIFICATIONS:
 Voltage: 220-240V/50Hz or 110-127V/60Hz
 Rated power: 1100W
 Air speed: 90m/s
 Waterproof: IPX1
 Shell: ABS
 Color: gray
 CTN Size: 62x32x43.5CM (4 pcs)
 CTN.G.W: 17kg

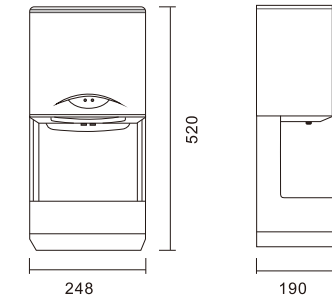

K2001-J1 (silver)

SPECIFICATIONS:
 Voltage: 220-240V/50Hz or 110-127V/60Hz
 Rated power: 1100W
 Air speed: 90m/s
 Waterproof: IPX1
 Shell: ABS
 Color: gray
 CTN Size: 61x42.5x46CM (4 pcs)
 CTN.G.W: 21.5kg

VIRIDIAN TECHNOLOGIES

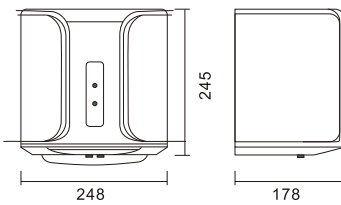

K2002 (white)

SPECIFICATIONS:
 Voltage: 220-240V/50Hz or 110-127V/60Hz
 Rated power: 1100W
 Air speed: 90m/s
 Waterproof: IPX1
 Shell: ABS
 Color: white
 CTN Size: 62x32x43.5CM (4 pcs)
 CTN.G.W: 17kg

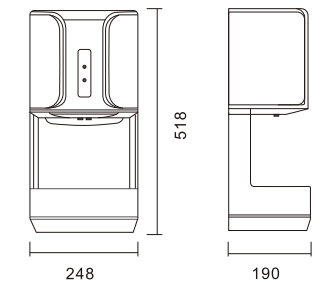

K2002-J1 (white)

SPECIFICATIONS:
 Voltage: 220-240V/50Hz or 110-127V/60Hz
 Rated power: 1100W
 Air speed: 90m/s
 Waterproof: IPX1
 Shell: ABS
 Color: white
 CTN Size: 61x42.5x46CM (4 pcs)
 CTN.G.W: 22kg

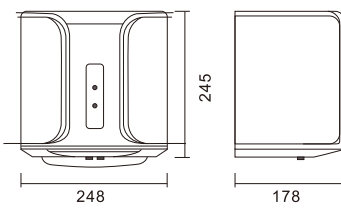

K2002 (silver)

SPECIFICATIONS:
 Voltage: 220-240V/50Hz or 110-127V/60Hz
 Rated power: 1100W
 Air speed: 90m/s
 Waterproof: IPX1
 Shell: ABS
 Color: gray
 CTN Size: 62x32x43.5CM (4 pcs)
 CTN.G.W: 17kg

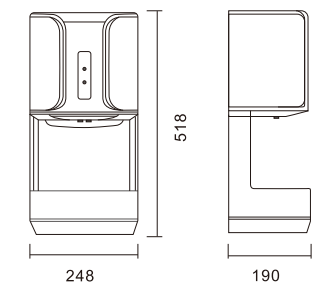

K2002-J1 (silver)

SPECIFICATIONS:
 Voltage: 220-240V/50Hz or 110-127V/60Hz
 Rated power: 1100W
 Air speed: 90m/s
 Waterproof: IPX1
 Shell: ABS
 Color: gray
 CTN Size: 61x42.5x46CM (4 pcs)
 CTN.G.W: 22kg



K8001A

Color: cream white/gray
Horizontal

K8001C

Color: cream white/gray
Horizontal

BABY CHANGING STATION

www.kuaierte.com

New Arrival



Folding

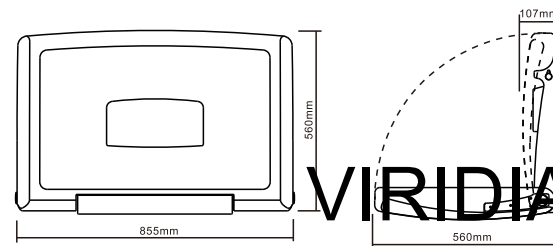

VIRIDIAN TECHNOLOGIES

- Hinge system design, closing the table when not in use, more efficient and rational using space
- Hinge bracket with metal design provides high strength and stability .maximum load 20kg;
- With high quality gas spring design ,allows one–hand opening and closing operation;
- Large table with adjustable seat belts to better protect baby.
- Built with sanitary pads diaper bag hooks and storage boxes
- Dimensions :
• Open: 855X560X495mm Closed: 855X560X107mm

- Hinge system design, closing the table when not in use, more efficient and rational using space
- Hinge bracket with metal design provides high strength and stability .maximum load 20kg;
- With high quality gas spring design ,allows one–hand opening and closing operation;
- Large table with adjustable seat belts to better protect baby.
- Dimensions :
• Open:855X560X495mm Closed:855X560X107mm

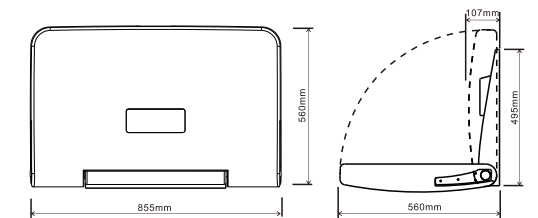

K8001B

Color: cream white
gray
Horizontal

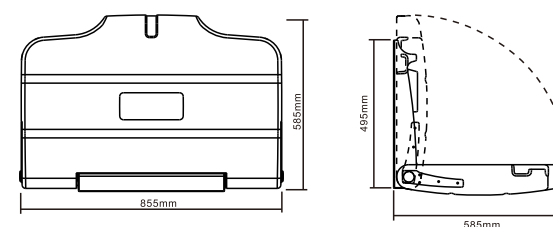

- Hinge system design, closing the table when not in use, more efficient and rational using space
- Hinge bracket with metal design provides high strength and stability .maximum load 20kg;
- With high quality gas spring design ,allows one–hand opening and closing operation;
- Large table with adjustable seat belts to better protect baby.
- Dimensions :
• Open:855X585X495mm Closed:855X585X107mm

K8003

Vertical

New Arrival



Folding



- Hinge system design, closing the table when not in use, more efficient and rational using space
- Hinge bracket with metal design provides high strength and stability .maximum load 20kg;
- With high quality gas spring design ,allows one–hand opening and closing operation;
- Large table with adjustable seat belts to better protect baby.

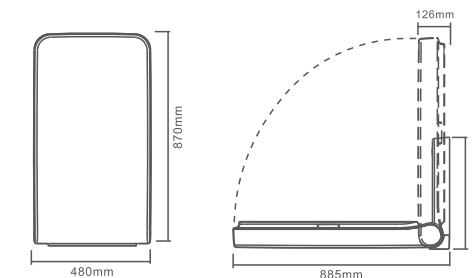



K8002A

Recessed mounted



Folding

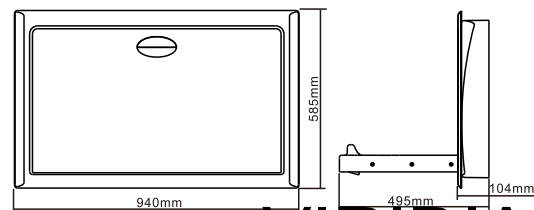

- 304 stainless steel cover, beautiful, luxury and firm
- Designed with concealed installation, achieving the integration of the aesthetic effect with the wall, and more space saved
- Hinge system design, closing the table when not in use, more efficient and rational using space
- Hinge bracket with metal design provides high strength and stability .maximum load 20kg;
- With high quality gas spring design ,allows one-hand opening and closing operation;
- A safety belt on the table, better protecting baby

K8002B

surface mounted



Folding

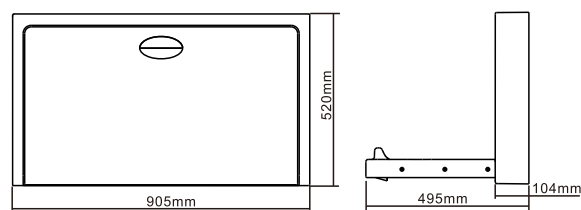

- 304 stainless steel cover, beautiful, luxury and firm
- Designed with concealed installation, achieving the integration of the aesthetic effect with the wall, and more space saved
- Hinge system design, closing the table when not in use, more efficient and rational using space
- Hinge bracket with metal design provides high strength and stability .maximum load 20kg;
- With high quality gas spring design ,allows one-hand opening and closing operation;
- A safety belt on the table, better protecting baby

CHILD PROTECTION SEAT

K8501

Color: cream white/gray



Folding

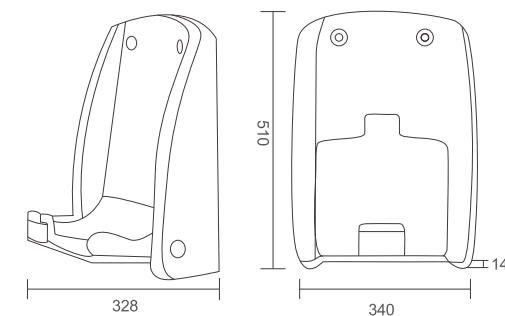

- Haft design, easy to open and close, saving space.
- Adjustable seat belts to better protect baby.
- Compact ultra slim profile
- Maximum load 25kg;
- Dimensions
Open: 510x340x328mm Closed: 510x340x145mm

VIRIDIAN TECHNOLOGIES

K8502A

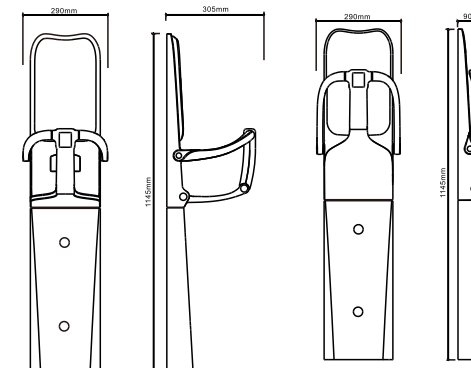

K8502B

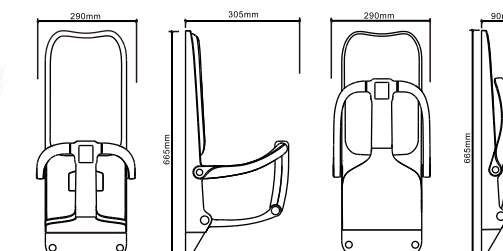



SMART SOAP DISPENSER

VIRIDIAN TECHNOLOGIES



AUTOMATIC SOAP DISPENSER

K4504A

Automatic Soap Dispenser

Standard Color: White,Black

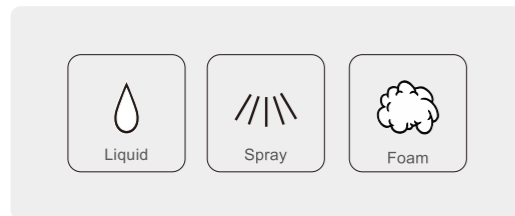

- Capacity Refillable bottle
- Liquid, Foam, Spray Soap dispenser (3 different pumps for options)
- Strong ABS front cover
- Requires 4x C alkaline batteries (Not included)
- Battery Life up to 140,000 Cycles
- No Touch Operation
- Available color: white or black
- Key lockable, preventing misuse
- Window viewer to monitor content levels
- Low battery indicator on front for easy servicing
- Size:252*140*100mm
- Can be mounted on the wall, desktop stand or floor stand

Low battery indicator



Window viewer



Optional for Liquid, Foam, Spray



1000ml Refillable Bottle



Can be mounted with metal desktop stand

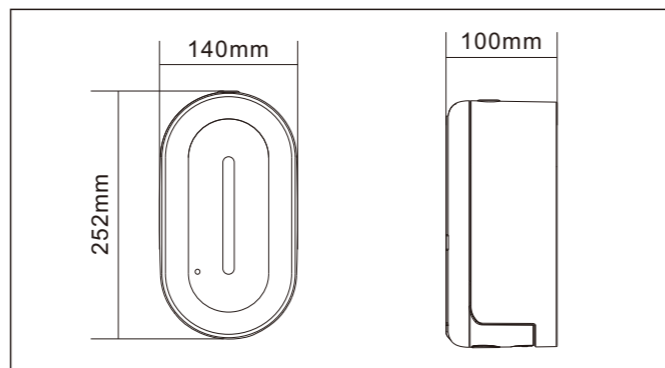

K4505A

Automatic Soap Dispenser

Standard Color: White,Black

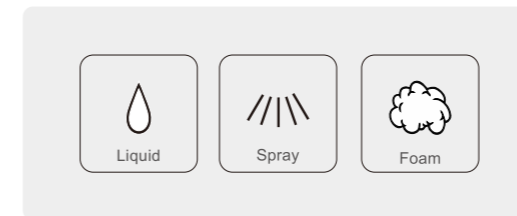

- Capacity Refillable bottle
- Liquid, Foam, Spray Soap dispenser (3 different pumps for options)
- Strong ABS front cover
- Requires 4x C alkaline batteries (Not included)
- Battery Life up to 140,000 Cycles
- No Touch Operation
- Available color: white or black
- Key lockable, preventing misuse
- Window viewer to monitor content levels
- Low battery indicator on front for easy servicing
- Size:250*130*100mm
- Can be mounted on the wall, desktop stand or floor stand

Low battery indicator



Window viewer



Optional for Liquid, Foam, Spray



1000ml Refillable Bottle



Can be mounted with metal desktop stand

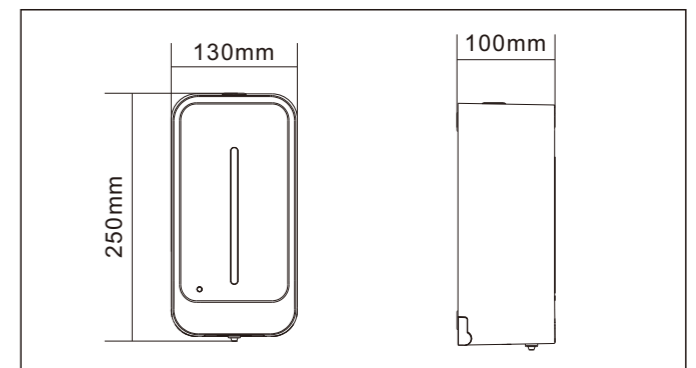

VIRIDIAN TECHNOLOGIES

K4503A

Automatic Soap Dispenser

Standard Color: White,Black

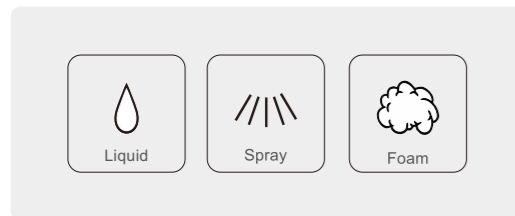

- 1650ml super large Capacity Refillable bottle (Also available for disposable bag)
- Liquid, Foam, Spray Soap dispenser (3 different pumps for options)
- Strong ABS with toughened glass front surface
- Requires 4 x C alkaline batteries (Not included)
- Battery Life up to 140,000 Cycles
- No Touch Operation
- Available color: white or black
- Key lockable, preventing misuse
- Window viewer to monitor content levels
- Low battery and failure indicator on front for easy servicing
- Size:292*160*121 mm
- Can be mounted on the wall, desktop stand or floor stand



Low battery and failure indicator



Optional for Liquid, Foam, Spray

Window viewer



1650ml Refillable Bottle



Can be mounted with metal desktop stand

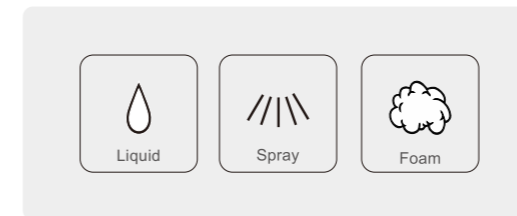
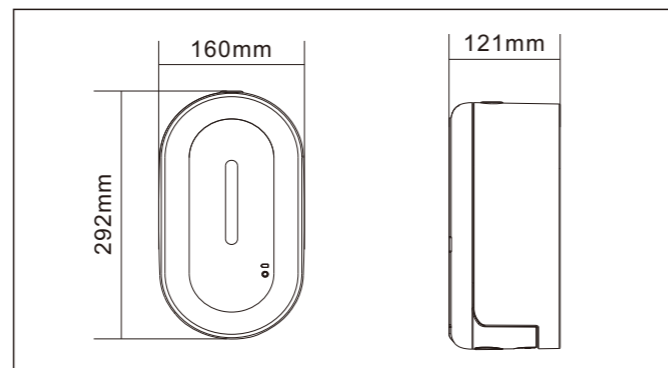

- 1300ml super large Capacity Refillable bottle (Also available for disposable bag)
- Liquid, Foam, Spray Soap dispenser (3 different pumps for options)
- Strong ABS with toughened glass front surface
- Requires 4 x C alkaline batteries (Not included)
- Battery Life up to 140,000 Cycles
- No Touch Operation
- Available color: white or black
- Key lockable, preventing misuse
- Window viewer to monitor content levels
- Low battery and failure indicator on front for easy servicing
- Size:275*140*120 mm
- Can be mounted on the wall, desktop stand or floor stand



K4506A

Automatic Soap Dispenser

Standard Color: White,Black

Low battery and failure indicator

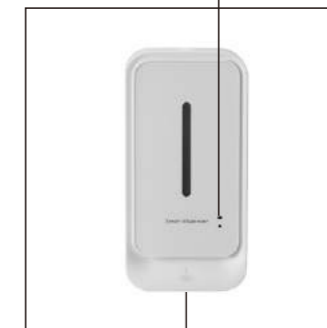

Optional for Liquid, Foam, Spray

Window viewer



1300ml Refillable Bottle



Can be mounted with metal desktop stand

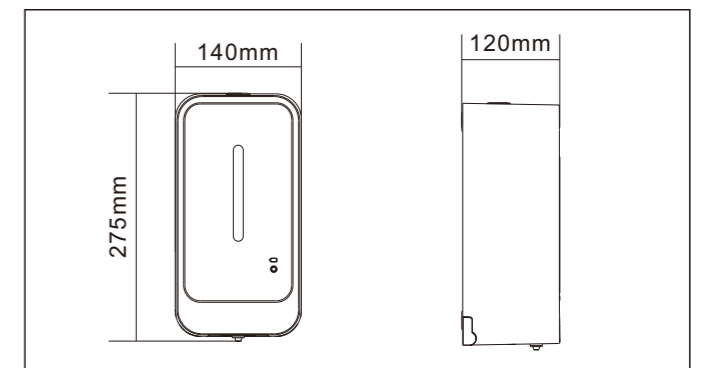

K4507A

Automatic Soap Dispenser

Standard Color: White,Black



- 1300ml super large Capacity Refillable bottle (Also available for disposable bag)
- Liquid, Foam, Spray Soap dispenser (3 different pumps for options)
- Strong ABS with toughened glass front surface
- Requires 4 x C alkaline batteries (Not included)
- Battery Life up to 140,000 Cycles
- No Touch Operation
- Available color: white or black
- Key lockable, preventing misuse
- Window viewer to monitor content levels
- Low battery and failure indicator on front for easy servicing
- Size:285*140*135mm
- Can be mounted on the wall, desktop stand or floor stand



Low battery and failure indicator



Optional for Liquid, Foam, Spray



Window viewer



Can be mounted with metal desktop stand

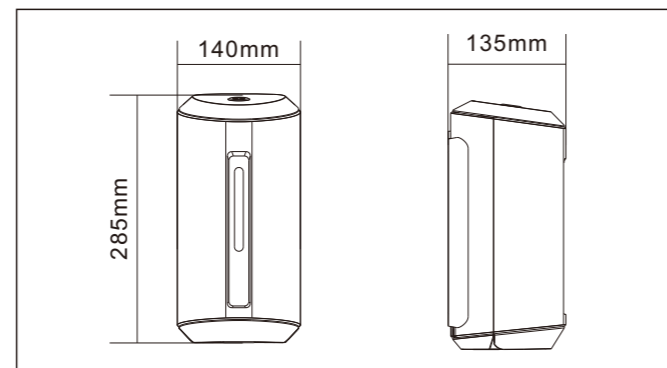

VIRIDIAN TECHNOLOGIES



Floor Stand for 1 unit



Floor Stand for 2 units



Liquid Filling Method

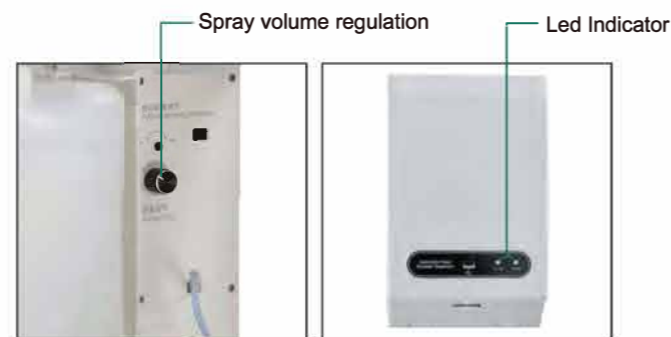
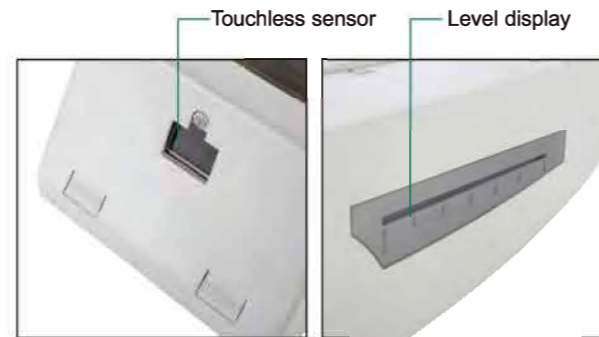
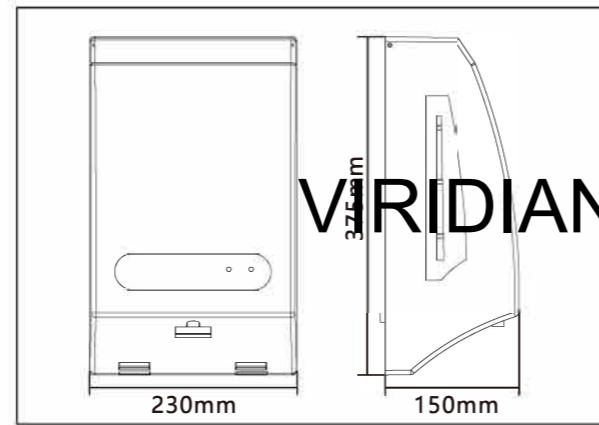
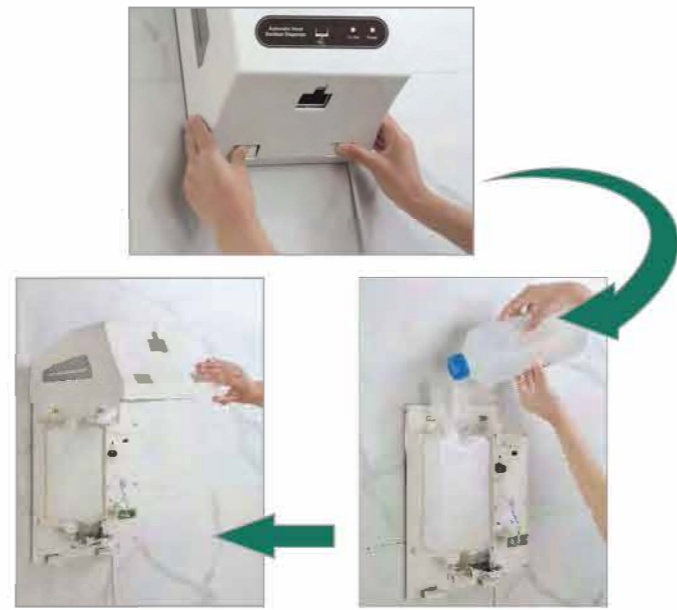

K6001A (Electric,25W)

- Automatically sprays liquid by infrared sensor, suitable for use of various disinfectant liquids and hand sanitizer
- Automatic wall-mounted liquid soap dispenser of super large 2.1 L capacity
- Suitable for high traffic facilities and for public use
- Level display located in the side of the dispenser. It constantly indicates the level of liquid available inside the dispenser
- Adjustable Spray volume from 0.6-10ml per use

K6001B (Battery Operated,3W)

- Automatically sprays liquid by infrared sensor, suitable for use of various disinfectant liquids and hand sanitizer
- Battery operated with super large 2.1 L capacity
- Suitable for high traffic facilities and for public use
- Level display located in the side of the dispenser. It constantly indicates the level of liquid available inside the dispenser
- Operates on 4 C-cell alkaline batteries (not provided) up to 240,000 cycles
- Adjustable Spray volume from 0.6-2.4ml per use



Liquid Filling Method

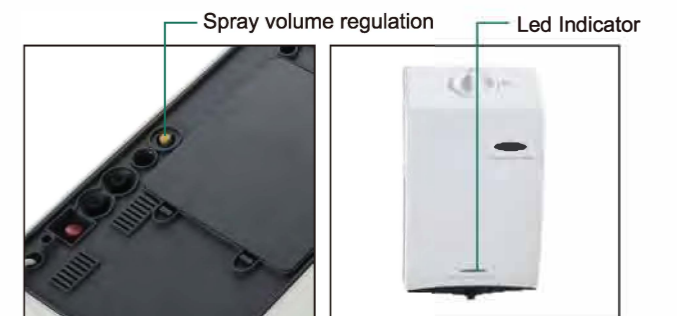
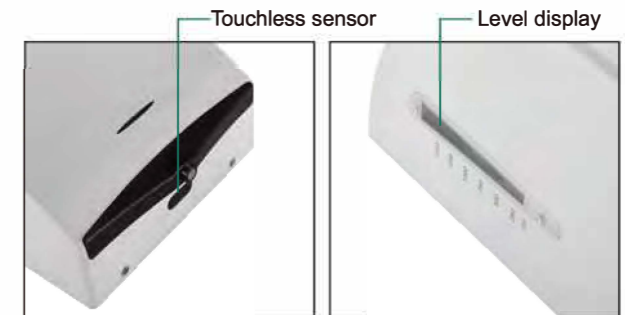
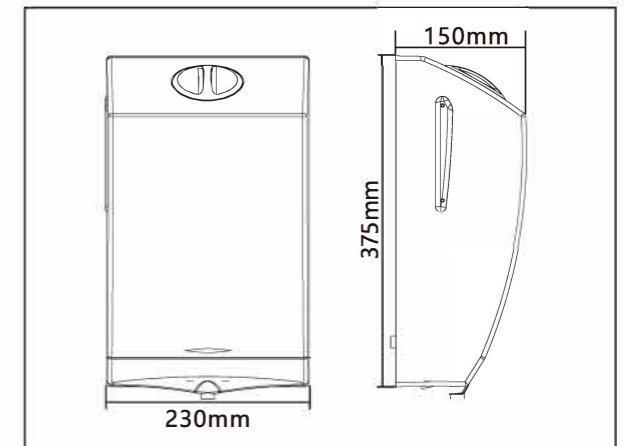

K6002A (Electric,25W)

- Automatically sprays liquid by infrared sensor, suitable for use of various disinfectant liquids and hand sanitizer
- Automatic wall-mounted liquid soap dispenser of super large 1.6 L capacity
- Suitable for high traffic facilities and for public use
- Level display located in the side of the dispenser. It constantly indicates the level of liquid available inside the dispenser
- Adjustable Spray volume from 0.6-10ml per use
- Easy to refill Liquid

K6002B (Battery Operated,3W)

- Automatically sprays liquid by infrared sensor, suitable for use of various disinfectant liquids and hand sanitizer
- Battery operated with super large 1.6 L capacity
- Suitable for high traffic facilities and for public use
- Level display located in the side of the dispenser. It constantly indicates the level of liquid available inside the dispenser
- Operates on 4 C-cell alkaline batteries (not provided) up to for 240,000 cycles
- Adjustable Spray volume from 0.6-2.4ml per use
- Easy to refill Liquid

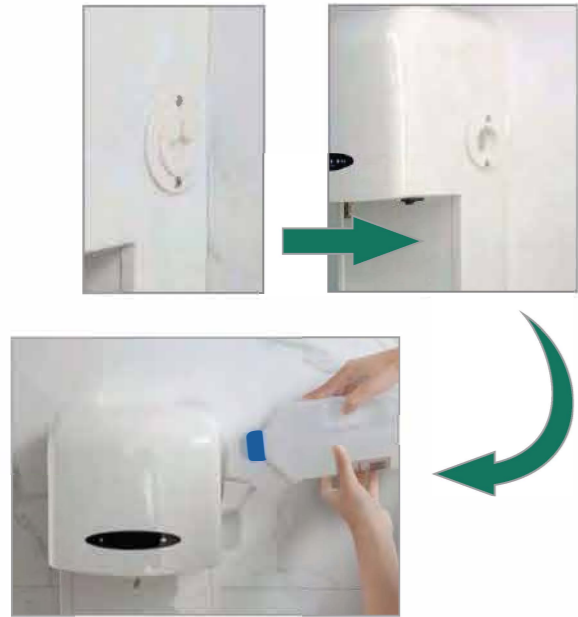

Automatic



Super Large Capacity



Touch-Free

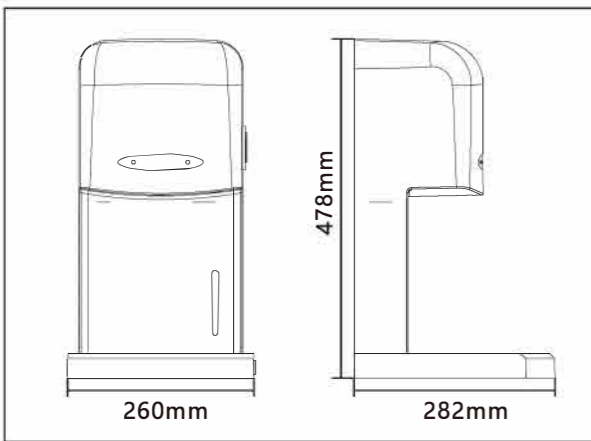

K6501A (Electric,25W)

- Automatically sprays liquid by infrared sensor, suitable for use of various disinfectant liquids and hand sanitizer
- Automatic wall-mounted liquid soap dispenser of super large 2.3 L capacity
- Suitable for very high traffic facilities and for public use
- Designed with a plate to prevent water from dripping on the floor

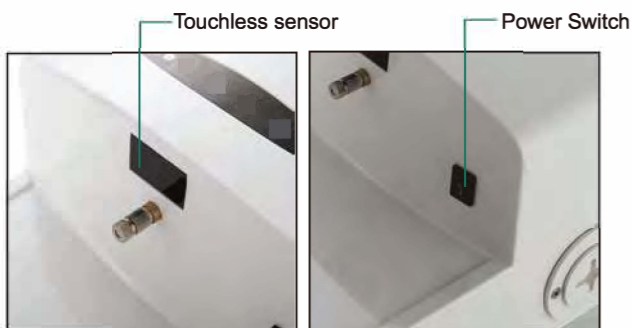

K6501B (Battery Operated,3W)

- Automatically sprays liquid by infrared sensor, suitable for use of various disinfectant liquids and hand sanitizer
- Battery operated with super large 2.3 L capacity
- Suitable for very high traffic facilities and for public use
- Operates on 4 C-cell alkaline batteries (not provided) up to for 240,000 cycles
- Designed with a plate to prevent water from dripping on the floor

VIRIDIAN TECHNOLOGIES



Automatic



Super Large Capacity



Touch-Free

Stainless steel model

K6502A (Electric,25W)

- Automatically sprays liquid by infrared sensor, suitable for use of various disinfectant liquids and hand sanitizer
- Automatic wall-mounted liquid soap dispenser of super large 2.3 L capacity
- Suitable for very high traffic facilities and for public use
- Designed with a plate to prevent water from dripping on the floor

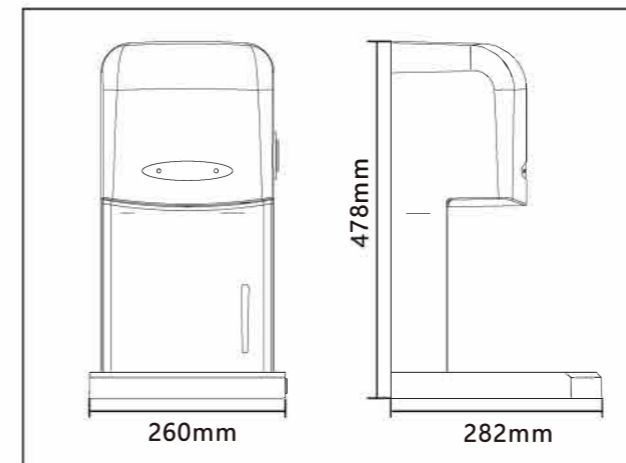

K6502B (Battery Operated,3W)

- Automatically sprays liquid by infrared sensor, suitable for use of various disinfectant liquids and hand sanitizer
- Battery operated with super large 2.3 L capacity
- Suitable for very high traffic facilities and for public use
- Operates on 4 C-cell alkaline batteries (not provided) up to for 240,000 cycles
- Designed with a plate to prevent water from dripping on the floor

COMBINATION UNIT

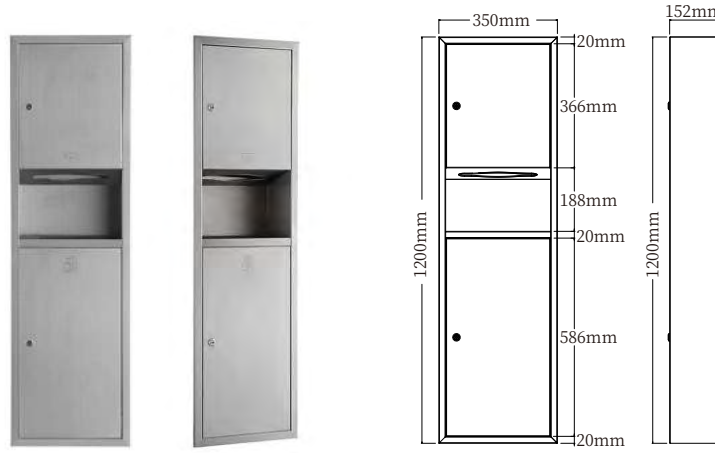

K5011

SPECIFICATIONS:

Function: Towel Dispenser and Waste Bin
 Unit Size: 1200*350*152mm
 Wall Opening Size: 1152*305*144mm
 Material: Stainless steel 304
 Installation: Recessed



K5015

SPECIFICATIONS:

Function: Towel Dispenser
 Unit Size: 300*118*398mm
 Wall Opening Size: 262*102*360mm
 Material: Stainless steel 304
 Installation: Recessed



K5012

SPECIFICATIONS:

Function: Towel Dispenser and Waste Bin
 Unit Size: 1200*350*150mm
 Material: Stainless steel 304
 Installation: Wall-Mounted

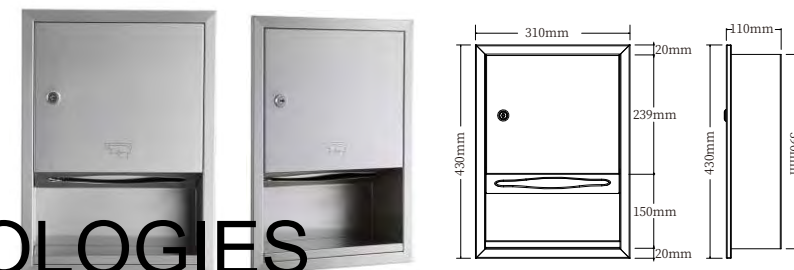

K5016

SPECIFICATIONS:

Function: Towel Dispenser
 Unit Size: 310*110*430mm
 Wall Opening Size: 272*100*390mm
 Material: Stainless steel 304
 Installation: Recessed

VIRIDIAN TECHNOLOGIES

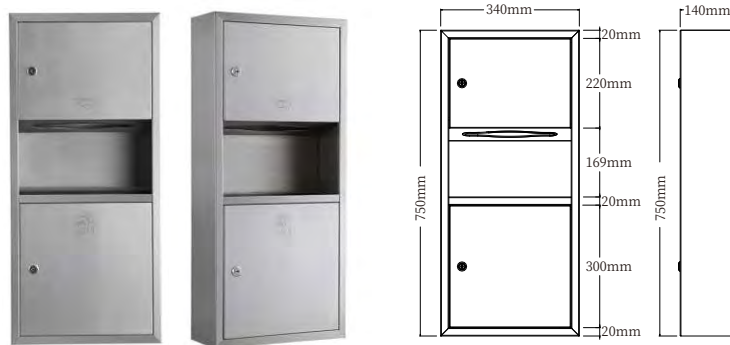

K5013

SPECIFICATIONS:

Function: Towel Dispenser and Waste Bin
 Unit Size: 750*340*140mm
 Material: Stainless steel 304
 Installation: Wall-Mounted



K5017

SPECIFICATIONS:

Function: Towel Dispenser, Waste Bin and Hand Dryer
 Unit Size: 1680*350*183mm
 Wall Opening Size: 1642*312*172mm
 Material: Stainless steel 304
 Installation: Recessed



K5014

SPECIFICATIONS:

Function: Towel Dispenser and Waste Bin
 Unit Size: 750*340*150mm
 Wall Opening Size: 712*305*141mm
 Material: Stainless steel 304
 Installation: Recessed

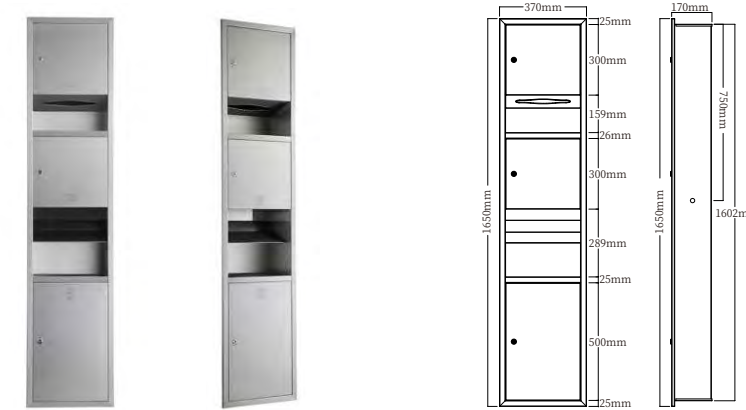

K5018

SPECIFICATIONS:

Function: Towel Dispenser, Waste Bin and Hand Dryer
 Unit Size: 1650*370*171mm
 Wall Opening Size: 1602*325*159mm
 Material: Stainless steel 304
 Installation: Recessed

PAPER TOWEL DISPENSER

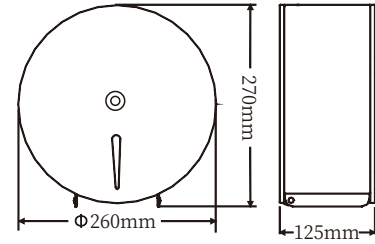

K7601

SPECIFICATIONS:

Size: 260mm*125mm*270mm
 Material: Stainless steel 304
 Installation: Wall-Mounted

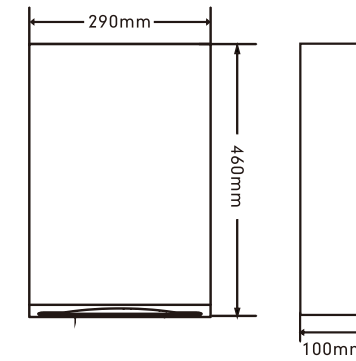

K7605

SPECIFICATIONS:

Size: 290mm*100mm*460mm
 Material: Stainless steel 304
 Installation: Wall-Mounted

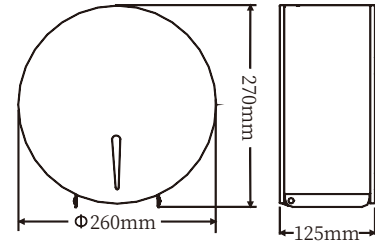

K7602

SPECIFICATIONS:

Size: 260mm*125mm*270mm
 Material: Stainless steel 304
 Installation: Wall-Mounted

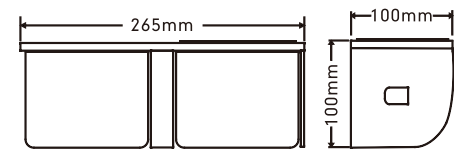
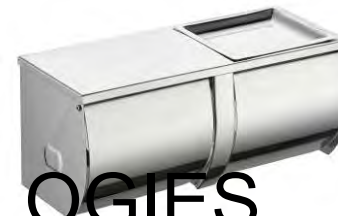

K7607

SPECIFICATIONS:

Size: 265mm*100mm*100mm
 Material: Stainless steel 304
 Installation: Wall-Mounted

VIRIDIAN TECHNOLOGIES

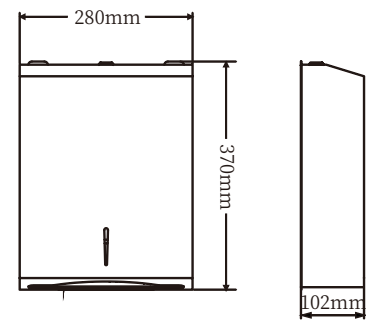

K7603

SPECIFICATIONS:

Size: 280mm*105mm*370mm
 Material: Stainless steel 304
 Installation: Wall-Mounted

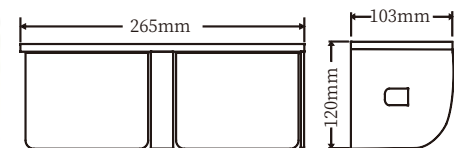

K7608

SPECIFICATIONS:

Size: 265mm*103mm*120mm
 Material: Stainless steel 304
 Installation: Wall-Mounted

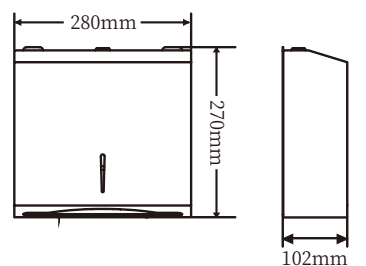

K7604

SPECIFICATIONS:

Size: 280mm*105mm*270mm
 Material: Stainless steel 304
 Installation: Wall-Mounted

SOAP DISPENSER

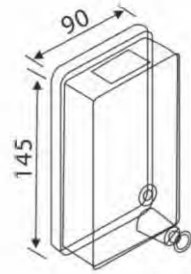

K4401A

SPECIFICATIONS:

Capability: 500ML
Size: 90mm*145mm
Material: Stainless steel 304
Installation: Wall-Mounted

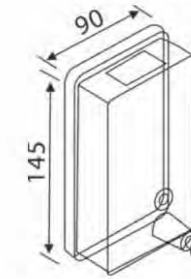

K4402A

SPECIFICATIONS:

Capability: 500ML
Size: 90mm*145mm
Material: Stainless steel 304
Installation: Wall-Mounted

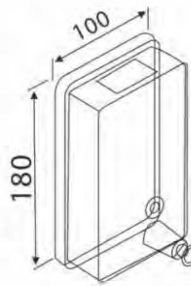

K4401B

SPECIFICATIONS:

Capability: 800ML
Size: 100mm*180mm
Material: Stainless steel 304
Installation: Wall-Mounted

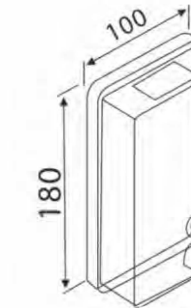

K4402B

SPECIFICATIONS:

Capability: 800ML
Size: 100mm*180mm
Material: Stainless steel 304
Installation: Wall-Mounted

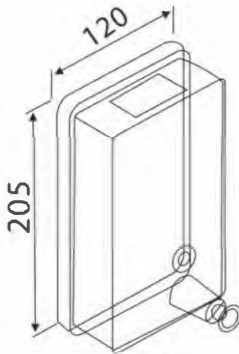

K4401C

SPECIFICATIONS:

Capability: 1000ML
Size: 120mm*205mm
Material: Stainless steel 304
Installation: Wall-Mounted

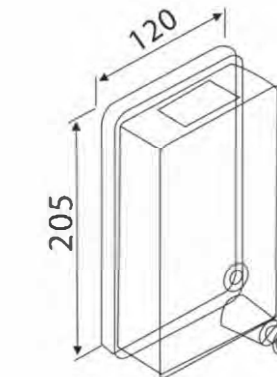

K4402C

SPECIFICATIONS:

Capability: 1000ML
Size: 120mm*205mm
Material: Stainless steel 304
Installation: Wall-Mounted



K4404B

SPECIFICATIONS:

Material: Stainless steel 304
Installation: Wall-Mounted



K4404A

SPECIFICATIONS:

Material: Stainless steel 304
Installation: Wall-Mounted

VIRIDIAN TECHNOLOGIES