

# SRD02 CONTINUOUSLY MODULATING TYPE DAMPER ACTUATOR (2, 4, 6, 8Nm)

## DESCRIPTION

SRD02 continuously modulating type damper actuator is controlled by DC 0~10V or 4~20mA signal, and can provide 0~10VDC position feedback signal. It is specially designed for damper control in HVAC system. There are 2, 4, 6, 8Nm models for optional.



## CHARACTERISTICS

### ● VARIOUS SIGNALS CONTROL

Standard type: 0~10Vdc control; the setting position of J3 is at point V

If you want 2~10Vdc or 4~20mA control type, please inform about it in your order. We will adjust the PCB in factory. You can use J3 setting to switch the control signals between 2~10Vdc and 4~20mA: point "V" is for 2~10Vdc control; point A is for 4~20mA control.

### ● SIMPLE INSTALLATION

Fix with square damper shaft. Damper shaft dimensions see below Dimension Diagram. The rotating angle of the actuator can be set by internal potentiometer (PT1). The match between working range and feedback signal is automatically done by the actuator.

### ● MANUEL OPERATION

It can be operated manually if needed: push the manual button on the actuator, the gearsings inside the actuator will break away. The damper can be operated manually when keep pushing the manual button. PLEASE DO NOT OPERATE WHEN POWER ON!

### ● HIGH DEPENDABLE PERFORMANCE

SRD02 modulating type damper actuator uses bi-directional magnetic clutch synchronous motor. It has overload protection and overtime protection, and no need limiter needed, the actuator will stop automatically when it runs to the end. And the damper actuator has a precision of 15° adjustable mechanical limiter.

## SPECIFICATIONS AND TECHNICAL DATA

MODEL	SRD02-02024E	SRD02-04024E	SRD02-06024E	SRD02-08024E
TORQUE	≥2Nm	≥4Nm	≥6Nm	≥8Nm
OPERATION TIME (50Hz/90°)	≈72s	≈108s		≈156s
RATED VOLTAGE	24VAC±10% (50/60Hz)			
CABLE	0.5~1.5mm <sup>2</sup>			
POWER CONSUMPTION	4VA when operating			
CONTROL SIGNAL	DC0(2)~10V or 4~20mA			
FACTORY SETTING	Working condition: DA (J1) Axle rotates to 0° (J4) when signal is lost			
POSITION PRECISION	±5%			
ROTATE ANGEL	90°<limitation≤ 95°			
NOISE LEVEL	Maximum 45dB(A)			
POSITION INDICATOR	Mechanical indication			
PROTECTION CLASS	IP 40			
AMBIENT TEMPERATURE	-5°C~+50°C			
STORAGE TEMPERATURE	-30°C~+70°C			
USAGE LIFE	>60000 times			

\* The accessories include 2 limitative baffles, 2 baffle setscrews (M3×6), 1 actuator body setscrews (ST4.8×12.5), and 1 aluminum gasket.

## WIRING DIAGRAM

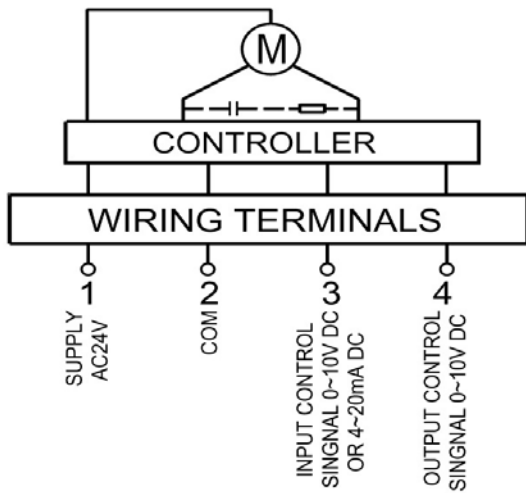

INPUT CONTROL SIGNAL		ROTATE DIRECTION
DA	RA	
INCREASING	DECREASING	↻
DECREASING	INCREASING	↻

## PCB SETTING DIAGRAM

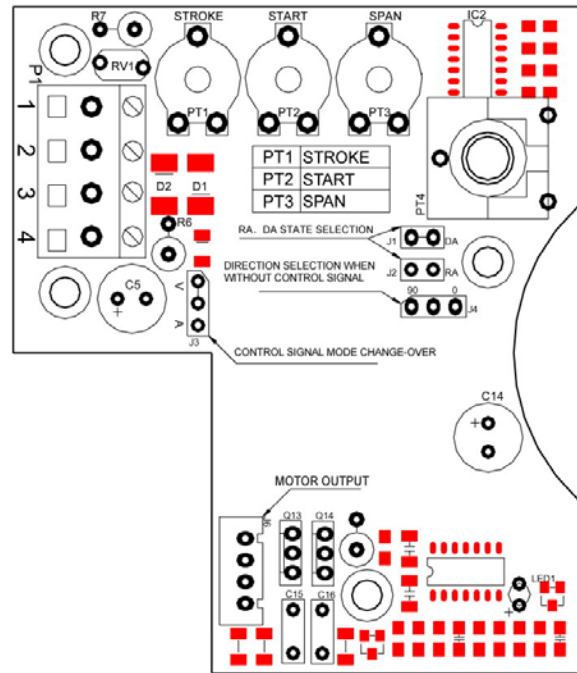

## DIMENSIONS (mm)

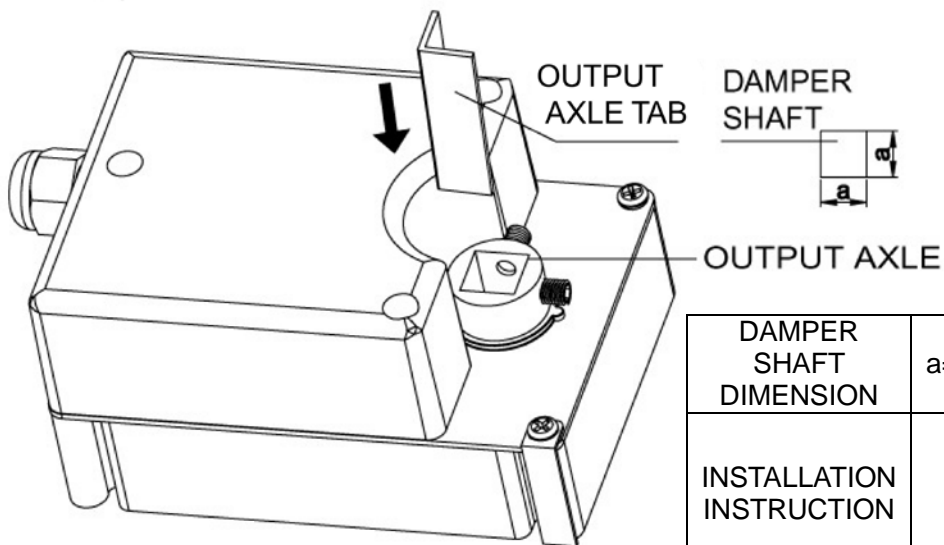
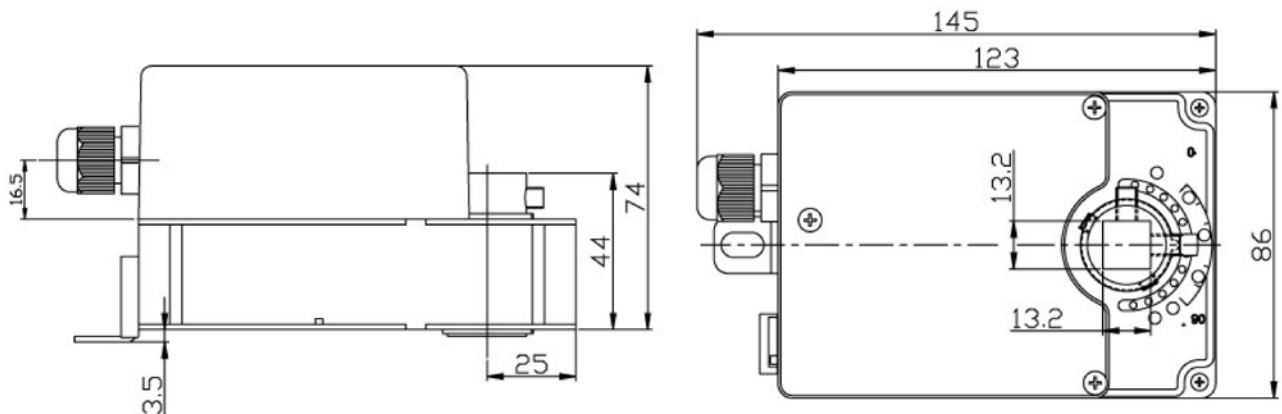

DAMPER SHAFT DIMENSION	a=13mm	a=10mm
INSTALLATION INSTRUCTION	—	Before installation, the Output Axle Tab should be put into the hole of Output Axle.

Note: Other sizes of aluminum gaskets can be made when the Damper Shaft dimension "a" is smaller than 10mm.

D06	D07	D08
060227	060630	061220