

LK01A LIQUID FLOW SWITCH

DESCRIPTION

LK01A Liquid Flow Switch is used in the circumstance where chain effect or cut-off protection is needed. It is to supervise the liquid flow rate through the pipes. When liquid inside the pipe circulates or cuts off, flow switch will correspondingly alters the ON/OFF state so as to control and protect external devices. Liquid Flow Switch is suitable for any liquid medium that makes no corruption on brass and tin-bronze and takes no effect on air-proof performance.



CHARACTERISTICS

- Suitable for pipes from 3/4" to 8"
- Applicable to cool/heat water system
- Strong die-casting aluminum alloyed casing and cover
- R1 or R3/4 external screw joint; Easy mounting (NPT, BSP)
- Dependable and durable parts such as forged brass, tin bronze, stainless-steel and high-strength flameproof engineering plastic
- Complete airproof design

INSTALLATION

- Mount on return pipes
- Mount on horizontal pipes
- Keep a certain distance from sources of turbulences (Elbows, valves, pumps, etc) so as to ensure steady working flow. Recommended minimum distance is equal to 5 times of the pipe's diameter

ADJUSTMENT OF FLOW RATE SETTING

Setting of LK01A is by means of relative screw. Fully tighten the screw to obtain minimum flow rate setting, fully loosen the screw to have maximum flow rate setting. The following table gives the values for limiting flow rate settings in relation to the pipe diameter and blade length. The LK01A is supplied ex-factory with the setting screw fully tightened (minimum setting).

MODEL	DIAMETER (inch)	CONNECTION THREAD	BLADE LENGTH (mm)	FLOW RATE WITH MINIMUM SETTING (m ³ /h)		FLOW RATE WITH MAXIMUM SETTING (m ³ /h)	
				SWITCH ACTION	SWITCH RETURN	SWITCH ACTION	SWITCH RETURN
LK01A-20	3/4"	R3/4	29	0.8	0.3	2.0	1.5
LK01A	1"	R1	34	0.9	0.4	2.0	1.5
	1 1/4"		34	1.2	0.6	2.6	1.9
	1 1/2"		57	1.6	0.9	3.3	2.6
	2"		57	3.2	2.2	7.1	5.1
	2 1/2"		88	4.2	3.5	8.0	7.0
	3"		88	6.3	5.7	12.0	10.5
	4"		88	13.5	12.0	28.0	26.0
	5"		167	12.1	9.0	30.0	28.0
	6"		167	17.2	12.0	35.0	32.0
	8"		167	42.0	36.0	90.0	85.0

The pre-set bolt has been adjusted before ex-factory. Users cannot adjust by themselves. The adjustable bolt can be adjusted and set according to special requirements. (See Fig. 1)

TECHNICAL DATA

- Rated voltage, rated current: 250VAC, 10(3)A
- Working pressure: 1.0MPa
- Max. testing pressure: 1.5MPa
- Max. fluid temperature: 110°C
- Storage temperature: -20~80°C
- Weight: 0.8Kg
- Protection class of casing: IP64/IP67

MATERIAL

- Casing and cover: Die-casting aluminum alloyed
- Bellow: Tin-bronze
- Blade: Stainless steel
- Joint: Forged brass, R1 or R3/4 external screw
- Wiring: 4x1.5mm² cable gland (Length made by order)

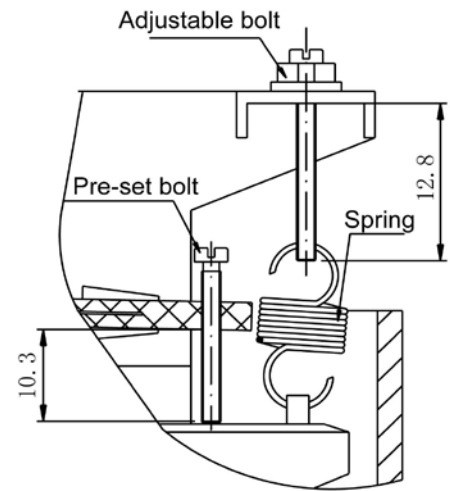

(Fig.1)

DIMENSIONS

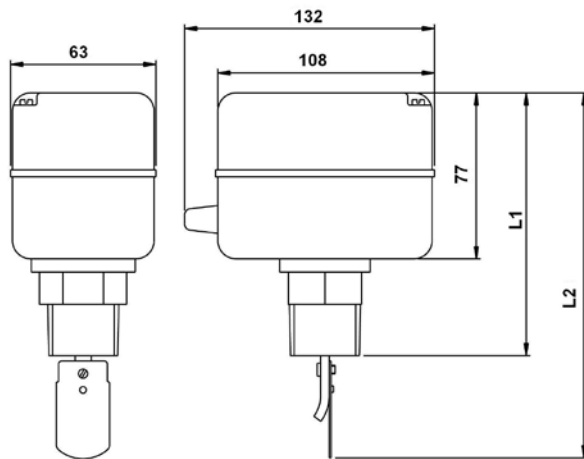
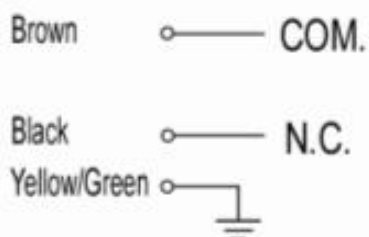

Fig.2

PIPE DIA.	3/4"	1"	1 1/4"	1 1/2"	2"	2 1/2"	3"	4"	5"	6"	8"
L1	108	118	118	118	118	118	118	118	118	118	118
L2	137	158	158	181	181	212	212	212	291	291	291

WIRING DIAGRAM

- 1-2 contact is normal-close (When flow switch is working, the contacts disconnect.)
- 1-3 contact is normal-open (When flow switch is working, the contacts connect.)



(Fig. 3)

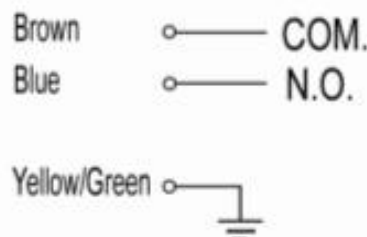

Earth wire (Yellow/Green), Common wire (Brown).

Two live wires: Normally-close contact (black); Normally-open contact (blue).