

SRE07 SERIES THERMOSTAT

DESCRIPTION

SRE07 series thermostat is mainly used in central air-conditioning and heating system. It detects room temperature and compares it with setting point, then provides control signal to central air-conditioning fan coil cool / heat motorized valves or other actuating mechanism. It can also control the fan blower of fan coil units and adjust the fan speed. When the SRE07 thermostat is turned off or get power supply after system power shut off, it can output a return signal to make the motorized valves or other actuating mechanism return.



CHARACTERISTICS

- ◆ Power surge and instant pulse protection.
- ◆ Output signal overtime protection function, auto-return function when the thermostat is turned off or get first power supply (SRE07F/D/U).
- ◆ Fixed setting temperature function
- ◆ Large LCD with background light shows the control state, ambient temperature, setting temperature and fan speed.
- ◆ With system on-off switch and fan speed switch.
- ◆ Inside or outside long-distance temperature sensitive element (NTC thermistor)
- ◆ With ABS fireproof plastic, compliance with UL-94 standard.

TECHNICAL DATA

NAME	SRE07A/B (2-pipe) SRE07C (4-pipe)	SRE07D / SRE07F	SRE07U		SRE07P	
POWER SUPPLY	24Vac; 220/230Vac		24Vac	220/230Vac	24Vac	220/230Vac
OUTPUT	24Vac, 1(0.8)A; 220/230Vac, 1(0.5)A		0-10Vdc 1mA	0-10Vdc 1mA	0-10Vdc 1mA	0-10Vdc 1mA
RETURN TIME	---	≥150s or ≥300s (for option)			---	
OVERTIME CUT OFF	---	Valve operate to the same direction ≥150s (≥300s), turns into overtime protection state.			---	
WORKING MODE	SRE07A/B/C/D: ON/OFF type; SRE07F/U/P: PID floating type					
POWER CONSUMPTION	0.6VA ; 6VA (without load)					
FAN OUTPUT	24Vac, 2(1) A; 220/230Vac, 2(1)A					
CONTROL PRECISION	±0.5°C (±1°F)					
CONTROL RANGE	10 - 30°C (50 - 86 °F)					
TEMP. DISPLAY	0~40°C (0.2°C) or 32~99°F (0.5 °F)					
BACKGROUND LIGHT	Blue—B; Green—G; or Yellow—Y					
SENSITIVE ELEMENT	NTC thermistor 10KΩ (when at 25 °C)					
WORKING TEMP.	0 ~ 55 °C/32 °F ~131 °F					
STORAGE TEMP.	-10 ~ 60 °C/14 °F ~140 °F					
AMBIENT HUMIDITY	90% RH maximum					

INSTRUCTION

1. **Cool/heat shift:** (SRE07A/B/C) in 2-pipe system, the thermostat is on Cooling state when the Power Supply switch is at position “❄”; on Heating state when the Power Supply switch is at position “☀”; and, the thermostat is shut off when the Power Supply switch is at position “●”. In 4-pipe system, the thermostat can only output heating or cooling signal according to the position of Power Supply switch. (SRE07F/D/U) When the power switch is turned to position “●”, the thermostat will self-check, and then make the valve run for 150 seconds (or 300 seconds) continuously towards the closing position. When it finishes operation, the thermostat will enter into turn off state. When the power supply switch turns to “❄”, the LCD will show the cooling state symbol “❄”, the action signal will output forward; when it moves to “☀”, the LCD will show the heating state symbol “☀”, the action signal will output backward. When it moves to “●”, the LCD will shut off, the valve will run for 150 seconds (or 300 seconds) continuously towards the closing end, then the system will be shut off.
2. **Fan:** When the thermostat is in cooling or heating state, turn the fan switch ❄-❄-❄, the LCD will display corresponding air volume symbol. The terminals will output power and provide operating power for the fan. If the thermostat isn't connected to the fan, only ❄ or ❄ can be shown on the LCD. The symbol ❄ can only be shown when the thermostat is directly connected to the fan correctly (except 24Vac models).

By selected JP8 connecting, it can be changed the control way from Thermostat to Fan. Mode “0” is used for thermostat connect fan directly, mode “1” is used for thermostat connect fan thru relay. If selected mode “0”, the thermostat connect fan thru relay, the LCD will display middle speed and low speed icon to relative setting accordingly, but it will still show low speed icon to hi speed setting, until thermostat connect fan directly, the LCD will show correct icon indication. If selected mode “1”, it can be shown correct icon indication when thermostat is not connect fan directly. It is pre-set mode “0” in factory for 220 / 230 V items, and pre-set mode “1” in factory for 24 V items. (refer picture for jumper selection)

- Temperature setting:** When user presses Δ (increase) / ∇ (decrease) button, LCD display temperature setting will show increase or decrease accordingly. The increase/decrease rate is 0.2°C/0.5 °F. The adjusting range is 10~30°C/50~86 °F. When user stops pressing the button for over 5 seconds, the thermostat will change the setting temperature data in its memory, and then the LCD shows the ambient temperature. (The ex-factory setting point is 25°C/77 °F.)
- Built-in/external sensor:** When built-in NTC thermistor is used, the jumper J3 should be put to position “Int”. If the external NTC sensor is used, the jumper J3 should be put to “Ext” position. (**Notice: SRE07U can't work with external sensor.**)
- Fixed setting temp. function:** Put the jumper JP4 to position 1, the setting point can't be changed by pressing increase or decrease buttons. (The default setting is on position 0. The setting point can be changed by pressing increase or decrease buttons)

WIRING DIAGRAM

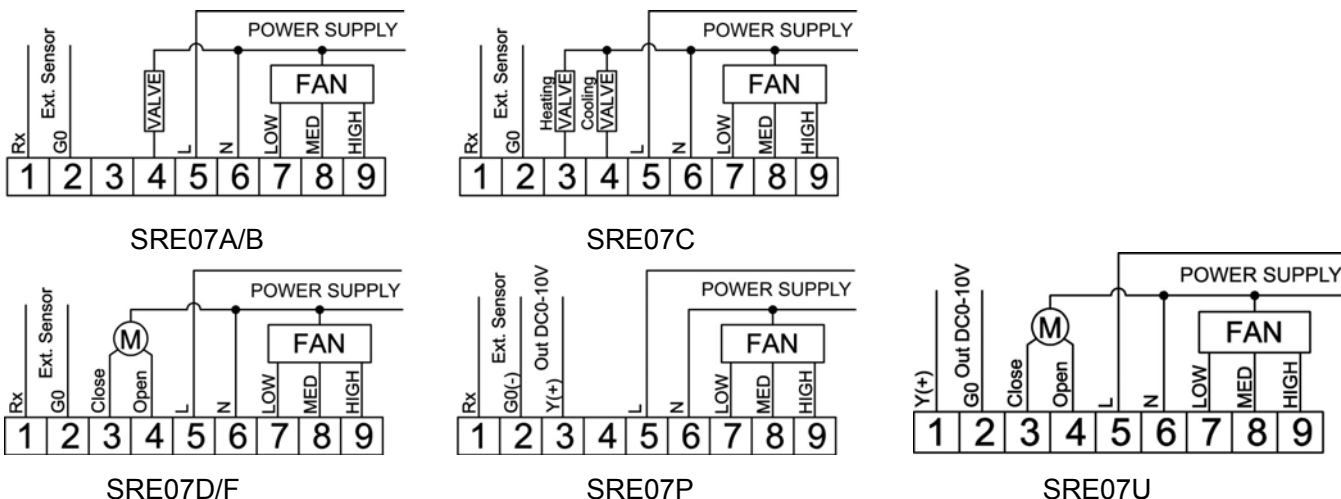

INSTALLATION INSTRUCTION

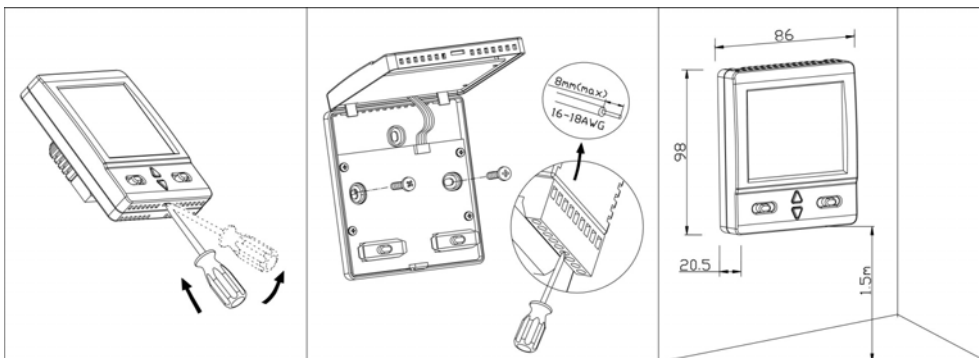

Please remove the wiring terminal from the thermostat before wiring.

JUMPER INSTRUCTION

