

# SRT04E ELECTRONIC THERMOSTAT

## DESCRIPTION

SRT04E series electronic thermostats are mainly used in central air-conditioning heating and cooling system. It provides temperature control for central air-conditioning fan coil cooling/heating zone valve or other electric actuator by the control signal which is produced by comparison of actual tested ambient temperature and setting temperature.



## CHARACTERISTICS

- Smart and simple design.
- Connected with internal or external sensor.
- Spare parts with high quality. It can control the temperature accurately and with high sensitivity and reliability.
- Convenient installation. Wall-mounted, embedded, embedded-plate or concealed mounted.

## SPECIFICATIONS AND TECHNICAL DATA

MODEL	SRT04EA	SRT04EB	SRT04EC
TYPE	2-pipe, heat-off-cool	2-pipe, off-cool	4-pipe, heat-off-cool
POWER SUPPLY	220V AC $\pm 10\%$ , 50/60 Hz		
OUTPUT SIGNAL	220V AC $\pm 10\%$ , 50/60 Hz	1A (relay output)	
POWER CONSUMPTION	6VA		
CONTROL RANGE	10~30°C		
CONTROL PRECISION	$\pm 0.8^\circ\text{C}$		
SENSITIVE ELEMENT	NTC thermistor (10K)		
RATED LOAD OF FAN SWITCH	6 (2) A 250V AC		
WIRING CONNECTION	Wiring terminal connection, wiring 0.5~1.5mm <sup>2</sup>		
HOUSING	Fire-proof ABS engineering plastic, compliance with UL94V-0 standard		
STORAGE TEMPERATURE RANGE	-10 ~ 60°C		
AMBIENT HUMIDITY	Max. 90% RH no condensation		

# WIRING DIAGRAM

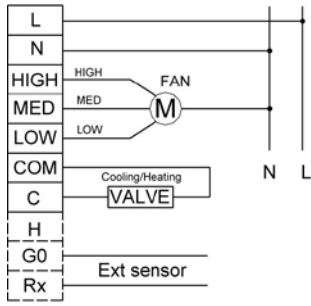

SRT04EA

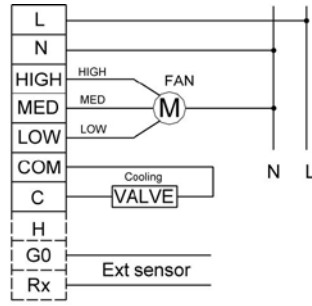

SRT04EB

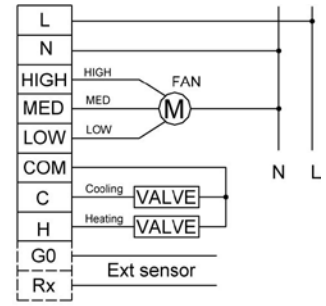

SRT04EC

# INSTALLATION DIAGRAM

