



United Technologies

## PRODUCT DATA

40LM040~100

# CHILLED WATER FAN COIL UNIT



## TABLE OF CONTENTS

DESCRIPTIONS	PAGE
<b>FEATURES &amp; SPECIFICATIONS</b>	<b>2</b>
<b>PHYSICAL DIMENSION - UNIT SIZE 40LM040</b>	<b>3</b>
<b>PHYSICAL DIMENSION - UNIT SIZE 40LM050</b>	<b>4</b>
<b>PHYSICAL DIMENSION - UNIT SIZE 40LM060</b>	<b>5</b>
<b>PHYSICAL DIMENSION - UNIT SIZE 40LM070</b>	<b>6</b>
<b>PHYSICAL DIMENSION - UNIT SIZE 40LM090</b>	<b>7</b>
<b>PHYSICAL DIMENSION - UNIT SIZE 40LM100</b>	<b>8</b>
<b>PERFORMANCE DATA COOLING CAPACITIES</b>	
40LM040	<b>9</b>
40LM050	<b>10</b>
40LM060	<b>11</b>
40LM070	<b>12</b>
40LM090	<b>13</b>
40LM100	<b>14</b>
<b>PERFORMANCE DATA PRESSURE DROP</b>	<b>15</b>
40LM040	
40LM050	
40LM060	
<b>PERFORMANCE DATA PRESSURE DROP</b>	<b>16</b>
40LM070	
40LM090	
40LM100	
<b>FAN PERFORMANCE</b>	<b>17</b>
40LM040	
40LM050	
40LM060	
<b>FAN PERFORMANCE</b>	<b>18</b>
40LM070	
40LM090	
40LM100	
<b>SOUND PRESSURE LEVEL DATA</b>	<b>19</b>
<b>ELECTRICAL DATA</b>	<b>20</b>
<b>GUIDE SPECIFICATIONS</b>	<b>21</b>

# FEATURES & SPECIFICATIONS

## Any Room, Every Room Flexibility In An Air Conditioning System

- Chilled Water Furred-in model with Plenum Fan Coil units
- The low silhouette styling of this unit makes it a popular choice for “in-the-ceiling” or “over the closet” applications in all types of building
- Horizontal ducted application
- Insulated & painted condensate drain pan and a factory fitted frame complete with filter media
- Installed with direct driven forward curved centrifugal fans and 3 speed motor ensures quiet operation
- Standard copper tube aluminum fins (Cu/Al) evaporator coil for maximum heat transfer
- Carrier Lanced Sine Wave fin pattern ensures energy efficient performance
- Units shall be manufactured as left-hand side (in the direction of air flow) piping connection as standard

### GENERAL

Type	Chilled Water Fan Coil						
Model	040	050	060	070	090	100	
Nominal Capacity	<i>kW</i>	12.2	14.7	17.6	20.9	26.5	29.9
	<i>Btu/hr</i>	41,580	50,251	60,218	71,467	90,367	102
Air Quantity (Range)	<i>l/s</i>	430 - 660	420 - 660	560 - 780	780-1280	820-1230	1270-1820
Power Supply	<i>V/Ph/Hz</i>	230/1/50					

FAN		Centrifugal Forward Curved Blades					
Type	Centrifugal Forward Curved Blades						
Drive	Direct Drive						
Quantity	<i>pcs</i>	1			2		
Max Rev	<i>rpm</i>	1500					
Diameter	<i>mm</i>	241					

MOTOR		Permanent Split Capacitor, 3 Speeds					
Type	Permanent Split Capacitor, 3 Speeds						
Quantity	<i>pcs</i>	1					
Power Input (*)	<i>kW</i>	0.47	0.47	0.83	1.01	1.01	1.41
Power Output	<i>kW</i>	0.32	0.32	0.46	0.75	0.75	0.80
Full Load Amps	<i>A</i>	2.46	2.46	4.40	4.55	4.55	7.40
Rev	<i>rpm</i>	1350	1350	1200	1360	1360	1405

COIL		Copper Tube, Aluminium Plate Fins					
Type	Copper Tube, Aluminium Plate Fins						
Row - Fins/in		2 - 15	3 - 15	4 - 15	3 - 15	4 - 15	3 - 15
Face Area	<i>m<sup>2</sup></i>	0.343	0.343	0.343	0.437	0.437	0.613

FILTER		Washable / Throw Away					
Type	Washable / Throw Away						
Size (H x W x D)	<i>mm</i>	398 x 744 x 12			398 x 944 x 12		398 x 1344 x 12
Quantity	<i>pcs</i>	1					

CONNECTIONS							
Supply	<i>Inch</i>	1" BSPT MPT					
Return	<i>Inch</i>	1" BSPT MPT					
Drain Pipe	<i>Inch</i>	3/4" NPT MPT					
Net weight	<i>Kg</i>	66.00	67.00	69.00	92.00	97.00	115.00

DIMENSIONS							
Height	<i>mm</i>	480					
Width	<i>mm</i>	1000			1200		1600
Length	<i>mm</i>	680					

FLA: FULL LOAD AMPS

\* Input power as per manufacturer rated input KW.

## UNIT SIZE 40LM040

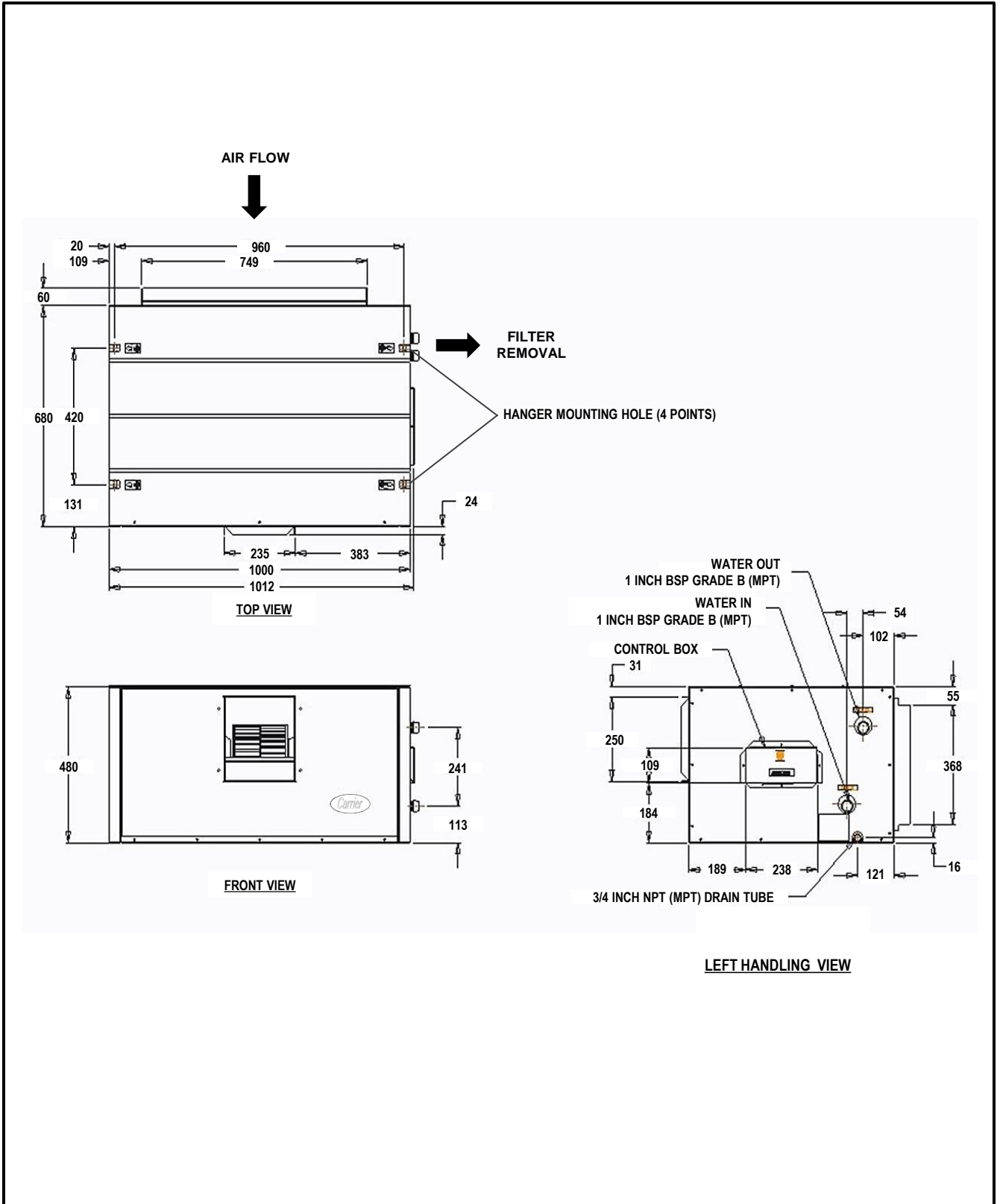

## UNIT SIZE 40LM050

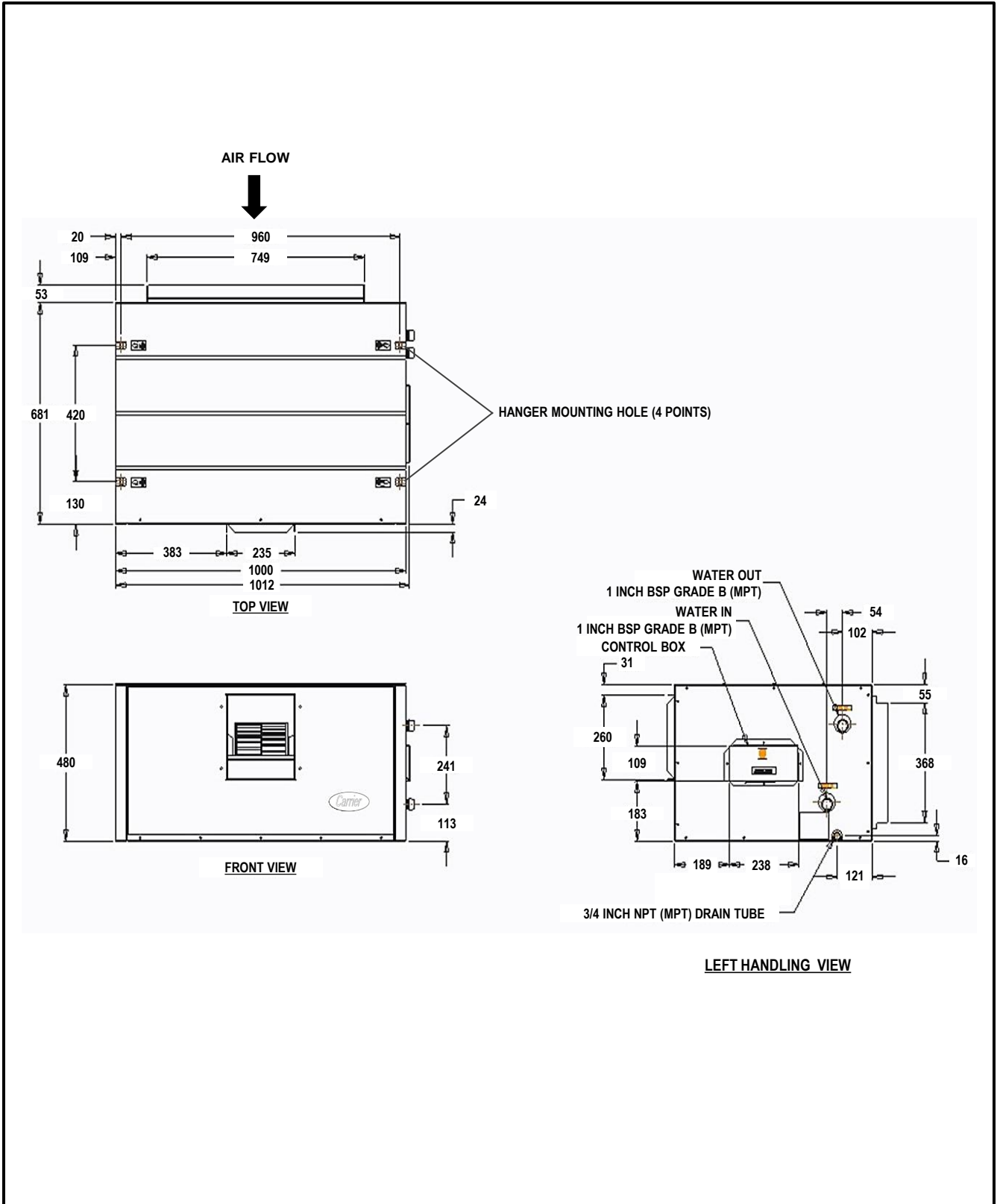

**UNIT SIZE 40LM060**

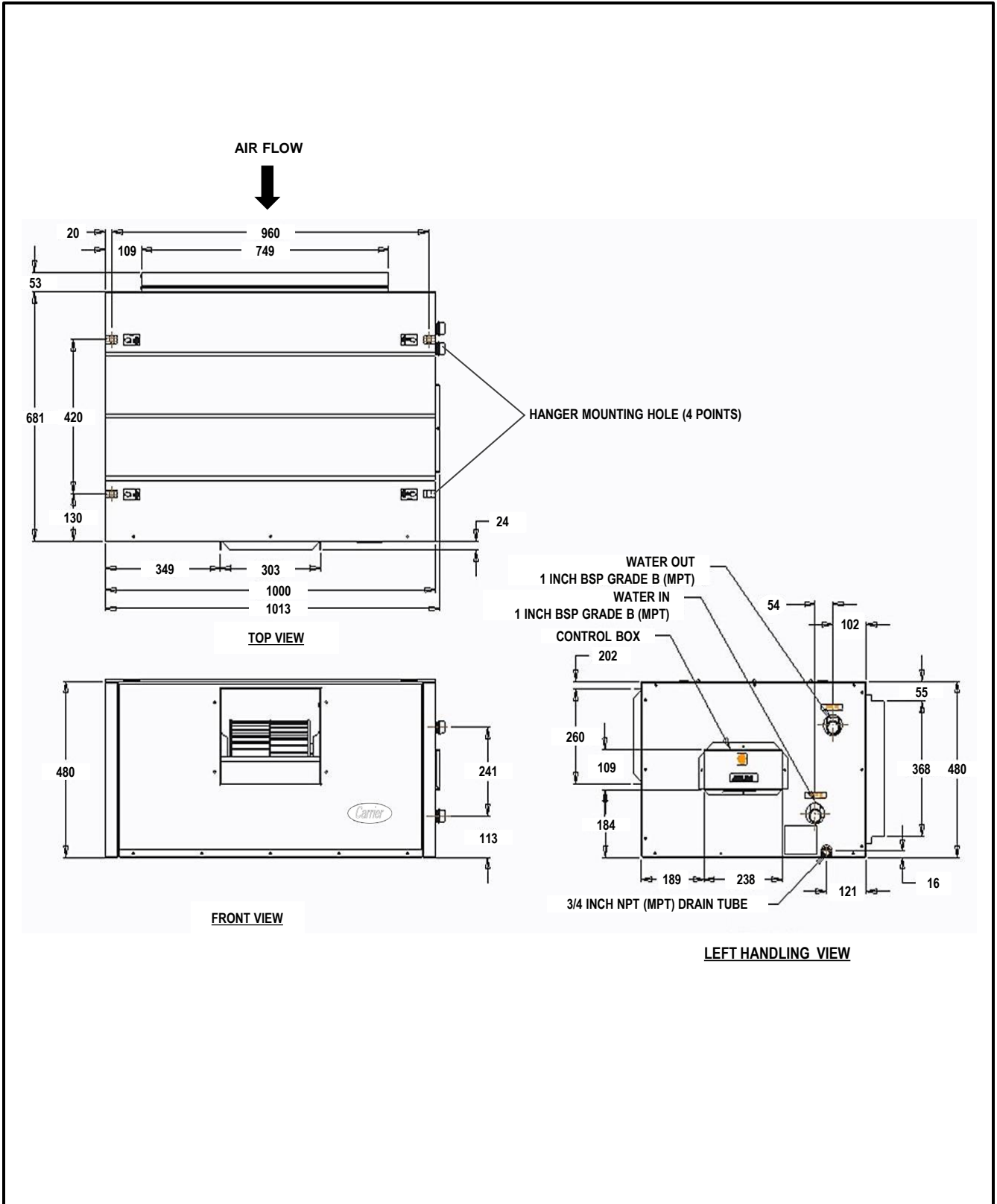

UNIT SIZE 40LM070

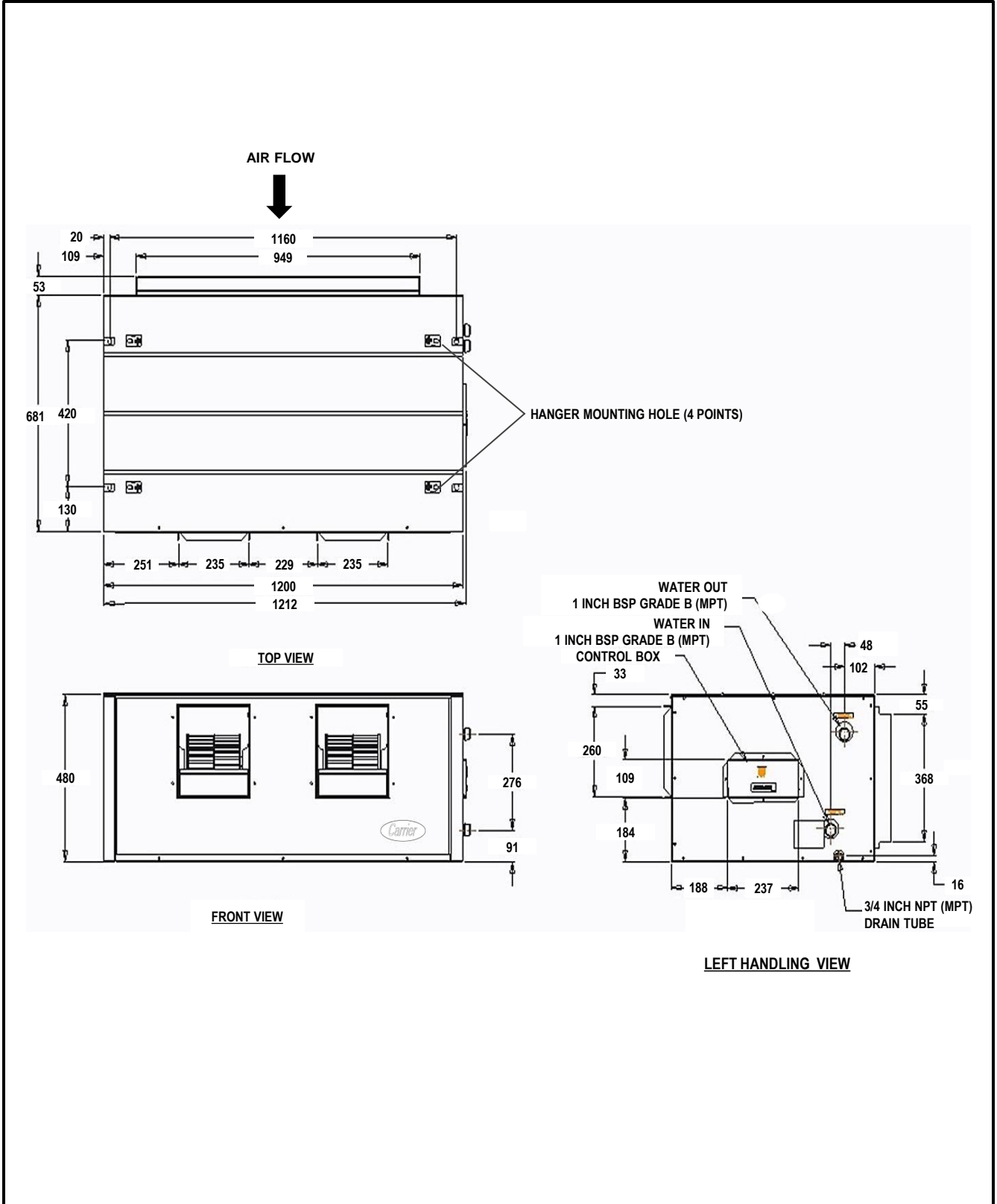

UNIT SIZE 40LM090

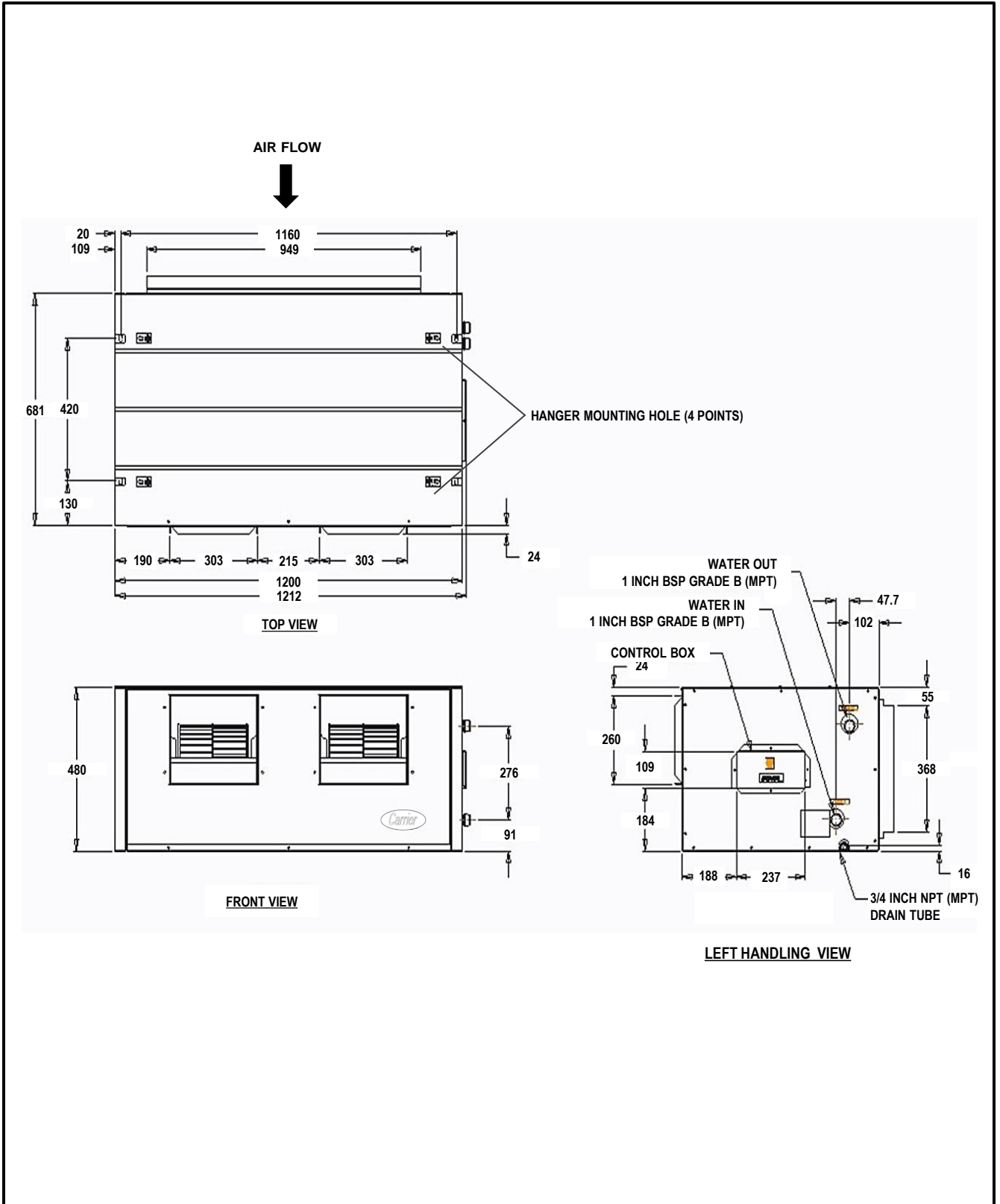



UNIT SIZE 40LM100

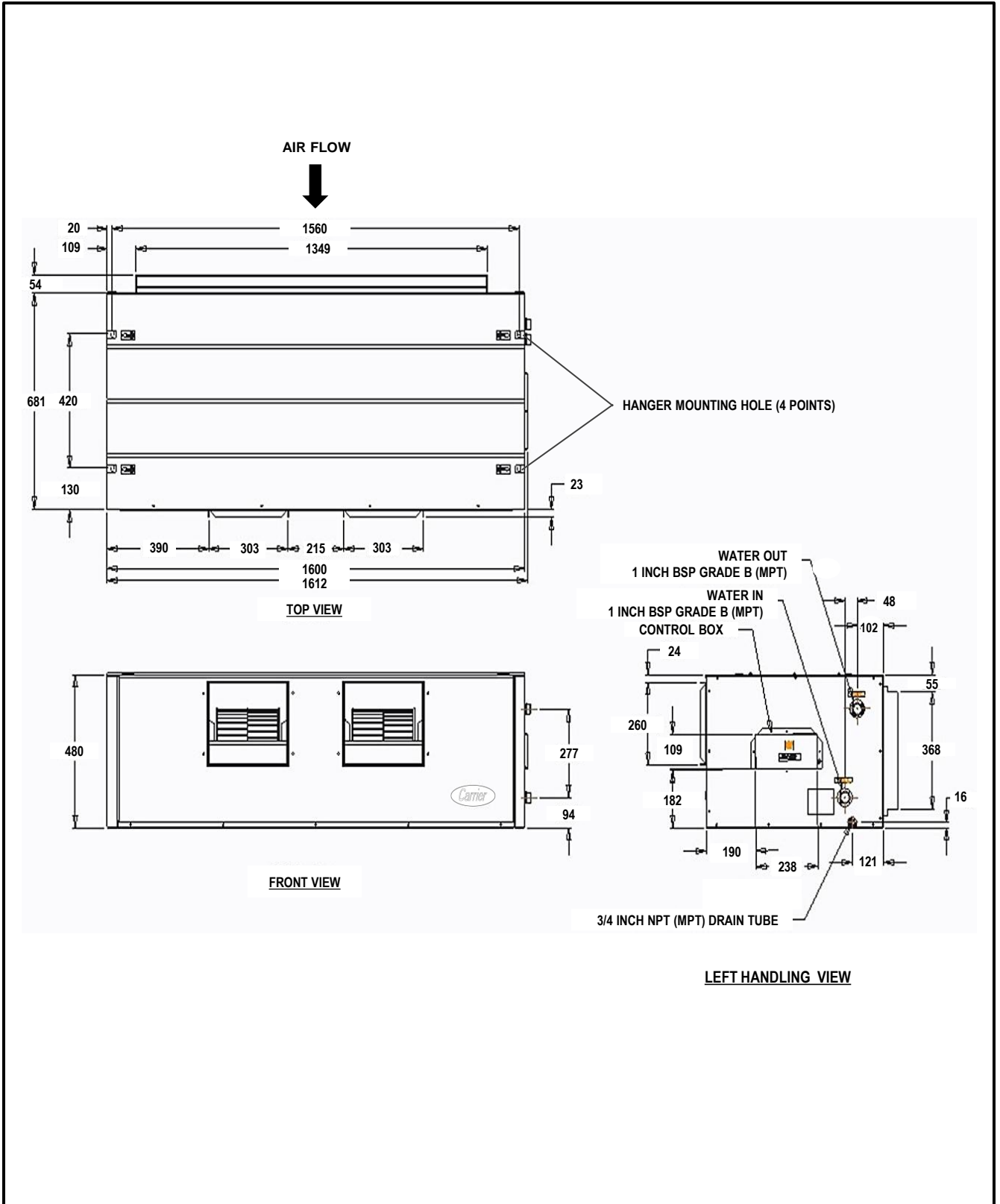

# PERFORMANCE DATA COOLING CAPACITIES

## 40LM040

Air Quality (l/s)	Ent Chilled Water Temp (°C)	Chilled Water Flow (l/min)	Ent Air Temperature DB/WB (°C)					
			25.0 / 17.0		27.0 / 19.5		29.0 / 22.0	
			TC	SHC	TC	SHC	TC	SHC
330	5	13	5.7	4.9	6.9	5.1	8.4	5.3
		26	6.7	5.4	8.5	5.8	10.4	6.1
		39	7.2	5.7	9.1	6.0	11.2	6.4
	6	13	5.3	4.8	6.5	4.9	8.0	5.1
		26	6.2	5.2	8.0	5.5	9.9	5.8
		39	6.7	5.4	8.6	5.8	10.6	6.2
	7	13	5.0	4.6	6.1	4.8	7.5	4.9
		26	5.7	5.0	7.4	5.3	9.3	5.6
		39	6.1	5.2	8.0	5.6	10.1	5.9
	8	13	4.6	4.4	5.7	4.6	7.0	4.7
		26	5.3	4.8	6.9	5.1	8.8	5.4
		39	5.6	4.9	7.4	5.3	9.5	5.7
9	13	4.2	4.2	5.3	4.4	6.6	4.6	
	26	4.8	4.6	6.3	4.9	8.2	5.2	
	39	5.1	4.7	6.8	5.1	8.9	5.4	
450	5	13	6.6	6.0	7.8	6.2	9.3	6.3
		26	7.9	6.7	9.9	7.0	12.1	7.3
		39	8.6	7.0	10.8	7.4	13.3	7.8
	6	13	6.1	5.8	7.3	5.9	8.8	6.1
		26	7.3	6.4	9.3	6.8	11.4	7.1
		39	7.9	6.8	10.2	7.2	12.6	7.5
	7	13	5.7	5.6	6.9	5.7	8.3	5.9
		26	6.8	6.2	8.6	6.5	10.8	6.8
		39	7.3	6.4	9.5	6.9	11.9	7.2
	8	13	5.3	5.3	6.5	5.5	7.8	5.7
		26	6.3	5.9	8.0	6.3	10.1	6.6
		39	6.7	6.1	8.8	6.6	11.2	7.0
9	13	5.0	5.0	6.0	5.3	7.3	5.5	
	26	5.8	5.6	7.3	6.0	9.5	6.3	
	39	6.1	5.9	8.1	6.3	10.5	6.7	
710	5	13	7.8	7.6	9.1	7.8	10.5	7.9
		26	9.7	8.8	11.7	9.2	14.3	9.4
		39	10.6	9.3	13.2	9.8	16.2	10.1
	6	13	7.3	7.3	8.6	7.6	10.0	7.7
		26	9.0	8.5	11.0	8.8	13.5	9.1
		39	9.9	8.9	12.4	9.4	15.3	9.8
	7	13	6.9	6.9	8.1	7.4	9.5	7.5
		26	8.4	8.1	10.3	8.5	12.7	8.8
		39	9.2	8.6	11.6	9.1	14.4	9.4
	8	13	6.5	6.5	7.6	7.1	9.0	7.3
		26	7.8	7.8	9.6	8.2	11.9	8.5
		39	8.5	8.2	10.7	8.7	13.5	9.1
9	13	6.2	6.2	7.1	6.9	8.4	7.0	
	26	7.3	7.3	8.9	7.9	11.1	8.2	
	39	7.8	7.8	9.8	8.4	12.6	8.8	

# PERFORMANCE DATA COOLING CAPACITIES

## 40LM050

Air Quality (l/s)	Ent Chilled Water Temp (°C)	Chilled Water Flow (l/min)	Ent Air Temperature DB/WB (°C)					
			25.0 / 17.0		27.0 / 19.5		29.0 / 22.0	
			TC	SHC	TC	SHC	TC	SHC
290	5	17	6.5	5.2	7.9	5.4	9.7	5.7
		33	7.4	5.6	9.3	6.1	11.5	6.5
		50	7.8	5.8	9.9	6.3	12.2	6.8
	6	17	6.0	5.0	7.5	5.2	9.2	5.5
		33	6.9	5.4	8.8	5.8	10.9	6.2
		50	7.3	5.6	9.3	6.0	11.6	6.5
	7	17	5.6	4.8	7.0	5.0	8.6	5.3
		33	6.3	5.1	8.2	5.5	10.3	5.9
		50	6.7	5.3	8.7	5.8	11.0	6.2
	8	17	5.1	4.6	6.5	4.8	8.1	5.1
		33	5.8	4.9	7.6	5.3	9.7	5.7
		50	6.1	5.0	8.1	5.5	10.4	6.0
	9	17	4.7	4.4	6.0	4.6	7.6	4.9
		33	5.3	4.7	7.0	5.0	9.1	5.4
		50	5.5	4.8	7.5	5.2	9.7	5.7
410	5	17	7.7	6.6	9.3	6.8	11.2	7.0
		33	9.2	7.3	11.5	7.7	14.0	8.1
		50	9.9	7.7	12.5	8.2	15.3	8.7
	6	17	7.2	6.4	8.8	6.6	10.6	6.8
		33	8.5	7.0	10.8	7.4	13.3	7.8
		50	9.1	7.3	11.7	7.8	14.5	8.3
	7	17	6.7	6.1	8.3	6.4	10.0	6.5
		33	7.9	6.7	10.0	7.1	12.6	7.5
		50	8.4	7.0	11.0	7.5	13.8	8.0
	8	17	6.3	5.9	7.7	6.1	9.4	6.3
		33	7.2	6.4	9.3	6.8	11.8	7.2
		50	7.7	6.7	10.2	7.2	13.0	7.7
	9	17	5.8	5.6	7.1	5.9	8.8	6.1
		33	6.6	6.1	8.6	6.5	11.1	6.9
		50	7.0	6.3	9.4	6.8	12.1	7.4
670	5	17	9.5	8.9	11.2	9.1	13.1	9.2
		33	11.7	10.2	14.3	10.5	17.4	10.9
		50	13.0	10.8	16.2	11.3	19.7	11.8
	6	17	9.0	8.6	10.5	8.8	12.5	8.9
		33	10.9	9.8	13.5	10.2	16.4	10.5
		50	12.1	10.4	15.1	10.9	18.7	11.4
	7	17	8.4	8.3	9.9	8.6	11.8	8.7
		33	10.2	9.4	12.6	9.8	15.5	10.2
		50	11.1	9.9	14.1	10.5	17.7	11.0
	8	17	7.9	7.9	9.3	8.3	11.1	8.4
		33	9.5	9.0	11.8	9.5	14.5	9.8
		50	10.2	9.5	13.1	10.0	16.6	10.6
	9	17	7.4	7.4	8.8	8.0	10.4	8.2
		33	8.7	8.6	10.9	9.1	13.6	9.4
		50	9.4	9.0	12.1	9.6	15.5	10.2

# PERFORMANCE DATA COOLING CAPACITIES

## 40LM060

Air Quality (l/s)	Ent Chilled Water Temp (°C)	Chilled Water Flow (l/min)	Ent Air Temperature DB/WB (°C)					
			25.0 / 17.0		27.0 / 19.5		29.0 / 22.0	
			TC	SHC	TC	SHC	TC	SHC
590	5	22	10.8	9.5	13.0	9.7	15.4	9.9
		44	13.2	10.6	16.4	11.2	20.1	11.7
		66	14.3	11.1	18.0	11.9	22.1	12.6
	6	22	10.1	9.2	12.2	9.4	14.7	9.6
		44	12.3	10.2	15.4	10.8	19.0	11.3
		66	13.2	10.7	16.9	11.4	20.9	12.1
	7	22	9.5	8.8	11.5	9.1	13.9	9.3
		44	11.3	9.8	14.4	10.3	18.0	10.9
		66	12.2	10.2	15.8	10.9	19.8	11.6
	8	22	8.8	8.5	10.8	8.8	13.1	9.0
		44	10.4	9.4	13.4	9.9	16.9	10.5
		66	11.2	9.7	14.6	10.4	18.6	11.1
9	22	8.2	8.1	10.0	8.5	12.3	8.7	
	44	9.6	8.9	12.4	9.5	15.8	10.0	
	66	10.2	9.3	13.5	10.0	17.5	10.7	
680	5	22	11.5	10.4	13.6	10.6	16.2	10.7
		44	14.2	11.7	17.5	12.3	21.4	12.8
		66	15.5	12.3	19.4	13.1	23.8	13.8
	6	22	10.8	10.0	12.9	10.3	15.4	10.4
		44	13.2	11.3	16.5	11.8	20.3	12.3
		66	14.4	11.8	18.3	12.6	22.6	13.3
	7	22	10.1	9.7	12.1	9.9	14.6	10.1
		44	12.3	10.8	15.4	11.4	19.2	11.9
		66	13.3	11.3	17.0	12.1	21.3	12.8
	8	22	9.5	9.3	11.4	9.6	13.7	9.8
		44	11.3	10.4	14.4	10.9	18.0	11.4
		66	12.2	10.8	15.8	11.5	20.1	12.2
9	22	8.9	8.9	10.7	9.3	12.9	9.5	
	44	10.4	9.9	13.3	10.5	16.8	11.0	
	66	11.1	10.3	14.6	11.0	18.8	11.7	
830	5	22	12.5	11.7	14.6	11.9	17.2	12.0
		44	15.6	13.4	19.1	13.9	23.2	14.4
		66	17.2	14.2	21.5	14.9	26.2	15.6
	6	22	11.8	11.3	13.9	11.6	16.3	11.7
		44	14.6	12.9	18.0	13.4	22.0	13.9
		66	16.0	13.6	20.1	14.4	24.9	15.0
	7	22	11.1	10.9	13.1	11.3	15.4	11.4
		44	13.6	12.4	16.9	13.0	20.7	13.4
		66	14.8	13.0	18.7	13.8	23.5	14.5
	8	22	10.4	10.4	12.3	10.9	14.6	11.1
		44	12.6	11.9	15.7	12.5	19.4	12.9
		66	13.6	12.5	17.4	13.2	22.1	13.9
9	22	9.8	9.8	11.5	10.5	13.7	10.7	
	44	11.7	11.4	14.5	12.0	18.2	12.4	
	66	12.5	11.9	16.2	12.7	20.6	13.4	

# PERFORMANCE DATA COOLING CAPACITIES

## 40LM070

Air Quality (l/s)	Ent Chilled Water Temp (°C)	Chilled Water Flow (l/min)	Ent Air Temperature DB/WB (°C)					
			25.0 / 17.0		27.0 / 19.5		29.0 / 22.0	
			TC	SHC	TC	SHC	TC	SHC
640	5	26	11.8	10.1	14.3	10.5	17.1	10.7
		52	13.9	11.2	17.5	11.9	21.4	12.5
		78	15.0	11.7	18.9	12.5	23.2	13.2
	6	26	11.0	9.8	13.4	10.1	16.2	10.4
		52	13.0	10.7	16.4	11.4	20.3	12.0
		78	13.8	11.2	17.8	12.0	22.0	12.7
	7	26	10.3	9.4	12.6	9.8	15.3	10.0
		52	12.0	10.3	15.3	10.9	19.2	11.6
		78	12.7	10.7	16.6	11.5	20.8	12.2
	8	26	9.5	9.0	11.8	9.4	14.4	9.7
		52	11.0	9.8	14.2	10.5	18.0	11.1
		78	11.7	10.2	15.4	11.0	19.6	11.7
9	26	8.8	8.6	10.9	9.0	13.5	9.3	
	52	10.0	9.4	13.1	10.0	16.9	10.6	
	78	10.6	9.7	14.2	10.5	18.4	11.2	
770	5	26	12.8	11.4	15.4	11.7	18.2	11.9
		52	15.4	12.7	19.1	13.4	23.4	14.0
		78	16.6	13.3	20.9	14.1	25.6	14.9
	6	26	12.0	10.9	14.5	11.3	17.2	11.5
		52	14.3	12.2	17.9	12.9	22.1	13.5
		78	15.4	12.7	19.6	13.6	24.3	14.3
	7	26	11.2	10.5	13.5	10.9	16.3	11.2
		52	13.2	11.7	16.7	12.3	20.9	13.0
		78	14.2	12.2	18.3	13.0	23.0	13.8
	8	26	10.4	10.1	12.6	10.6	15.4	10.8
		52	12.2	11.2	15.5	11.8	19.6	12.5
		78	13.0	11.6	17.0	12.5	21.6	13.2
9	26	9.7	9.6	11.8	10.2	14.4	10.4	
	52	11.2	10.7	14.4	11.3	18.3	12.0	
	78	11.8	11.1	15.6	11.9	20.2	12.7	
920	5	26	13.8	12.6	16.3	13.0	19.2	13.1
		52	16.8	14.3	20.7	14.9	25.2	15.5
		78	18.2	15.0	22.9	15.9	28.0	16.6
	6	26	13.0	12.2	15.4	12.6	18.3	12.7
		52	15.6	13.7	19.3	14.3	23.8	14.9
		78	16.9	14.4	21.4	15.2	26.5	16.0
	7	26	12.1	11.7	14.4	12.1	17.3	12.4
		52	14.4	13.2	18.1	13.8	22.5	14.4
		78	15.6	13.8	20.0	14.6	25.0	15.4
	8	26	11.3	11.2	13.5	11.7	16.3	12.0
		52	13.4	12.6	16.9	13.3	21.1	13.9
		78	14.3	13.2	18.5	14.0	23.5	14.8
9	26	10.6	10.6	12.7	11.3	15.3	11.6	
	52	12.3	12.0	15.6	12.8	19.7	13.3	
	78	13.1	12.5	17.0	13.4	22.0	14.2	

# PERFORMANCE DATA COOLING CAPACITIES



## 40LM090

Air Quality (l/s)	Ent Chilled Water Temp (°C)	Chilled Water Flow (l/min)	Ent Air Temperature DB/WB (°C)					
			25.0 / 17.0		27.0/ 19.5		29.0 / 22.0	
			TC	SHC	TC	SHC	TC	SHC
870	5	31	16.6	14.2	20.0	14.6	23.8	15.0
		63	19.8	15.8	24.7	16.7	30.3	17.5
		94	21.1	16.4	26.7	17.5	32.7	18.6
	6	31	15.5	13.7	18.8	14.1	22.6	14.5
		63	18.4	15.1	23.2	16.0	28.7	16.9
		94	19.6	15.7	25.0	16.8	31.1	17.9
	7	31	14.4	13.2	17.6	13.6	21.4	14.0
		63	16.9	14.5	21.6	15.4	27.1	16.2
		94	18.0	15.0	23.4	16.1	29.4	17.2
	8	31	13.4	12.6	16.4	13.1	20.1	13.5
		63	15.5	13.8	20.1	14.7	25.5	15.6
		94	16.5	14.3	21.7	15.4	27.6	16.4
9	31	12.4	12.1	15.3	12.6	18.9	13.0	
	63	14.2	13.2	18.6	14.1	23.8	14.9	
	94	14.9	13.6	20.0	14.7	25.9	15.7	
1050	5	31	18.0	16.0	21.4	16.4	25.4	16.6
		63	21.8	18.0	27.0	18.8	33.0	19.7
		94	23.5	18.8	29.6	19.9	36.2	21.0
	6	31	16.9	15.4	20.2	15.8	24.1	16.1
		63	20.3	17.2	25.3	18.1	31.3	19.0
		94	21.8	18.0	27.8	19.1	34.4	20.2
	7	31	15.8	14.8	18.9	15.3	22.7	15.6
		63	18.7	16.5	23.7	17.4	29.5	18.2
		94	20.1	17.2	25.9	18.3	32.5	19.4
	8	31	14.7	14.2	17.8	14.8	21.4	15.1
		63	17.3	15.8	22.0	16.7	27.7	17.5
		94	18.4	16.4	24.0	17.5	30.5	18.6
9	31	13.7	13.6	16.6	14.3	20.1	14.6	
	63	15.8	15.1	20.4	16.0	25.9	16.9	
	94	16.8	15.6	22.1	16.7	28.6	17.9	
1280	5	31	19.5	18.0	22.9	18.3	26.9	18.5
		63	23.9	20.4	29.4	21.3	35.8	22.1
		94	26.1	21.5	32.6	22.7	39.9	23.7
	6	31	18.3	17.3	21.6	17.8	25.5	18.0
		63	22.3	19.6	27.7	20.5	33.9	21.3
		94	24.3	20.6	30.6	21.8	37.8	22.8
	7	31	17.2	16.7	20.4	17.2	24.1	17.5
		63	20.8	18.9	25.9	19.8	31.9	20.5
		94	22.3	19.7	28.4	20.9	35.7	22.0
	8	31	16.1	16.0	19.1	16.7	22.7	16.9
		63	19.2	18.1	24.1	19.0	29.9	19.8
		94	20.6	18.9	26.4	20.0	33.5	21.1
9	31	15.1	15.1	17.9	16.1	21.3	16.4	
	63	17.7	17.2	22.3	18.3	28.0	19.0	
	94	18.9	18.0	24.4	19.2	31.3	20.3	

# PERFORMANCE DATA COOLING CAPACITIES

## 40LM100

Air Quality (l/s)	Ent Chilled Water Temp (°C)	Chilled Water Flow (l/min)	Ent Air Temperature DB/WB (°C)					
			25.0 / 17.0		27.0 / 19.5		29.0 / 22.0	
			TC	SHC	TC	SHC	TC	SHC
1040	5	35	17.4	15.5	21.0	16.0	24.9	16.3
		69	20.9	17.3	26.1	18.2	31.9	19.0
		104	22.7	18.2	28.6	19.3	35.0	20.3
	6	35	16.3	15.0	19.8	15.5	23.6	15.8
		69	19.5	16.6	24.5	17.5	30.3	18.3
		104	20.9	17.3	26.8	18.5	33.2	19.5
	7	35	15.3	14.4	18.6	14.9	22.3	15.3
		69	18.0	15.9	22.8	16.8	28.6	17.7
		104	19.4	16.6	25.0	17.7	31.4	18.8
	8	35	14.3	13.8	17.3	14.4	21.0	14.8
		69	16.6	15.2	21.2	16.1	26.8	17.0
		104	17.8	15.8	23.2	17.0	29.6	18.0
9	35	13.3	13.2	16.1	13.9	19.8	14.3	
	69	15.2	14.5	19.6	15.4	25.1	16.3	
	104	16.1	15.1	21.4	16.2	27.7	17.3	
1340	5	35	19.4	18.0	22.9	18.5	26.9	18.7
		69	23.7	20.4	29.1	21.3	35.4	22.0
		104	25.8	21.5	32.4	22.7	39.6	23.6
	6	35	18.3	17.4	21.6	18.0	25.6	18.2
		69	22.1	19.7	27.2	20.5	33.6	21.3
		104	24.0	20.6	30.4	21.8	37.6	22.8
	7	35	17.1	16.8	20.3	17.4	24.2	17.6
		69	20.4	18.9	25.4	19.7	31.6	20.5
		104	22.2	19.8	28.3	21.0	35.4	22.0
	8	35	16.0	16.0	19.0	16.8	22.8	17.1
		69	18.9	18.0	23.7	19.0	29.7	19.8
		104	20.3	18.9	26.2	20.1	33.3	21.2
9	35	15.1	15.1	17.8	16.2	21.5	16.6	
	69	17.5	17.2	22.0	18.3	27.7	19.1	
	104	18.7	18.0	24.1	19.2	31.1	20.3	
1840	5	35	21.9	21.4	25.2	22.0	29.3	22.1
		69	27.0	24.7	32.7	25.5	39.5	26.2
		104	30.0	26.3	37.0	27.5	45.1	28.3
	6	35	20.6	20.5	23.8	21.3	27.9	21.6
		69	25.3	23.7	30.8	24.7	37.3	25.4
		104	2.8	25.3	34.6	26.4	42.7	27.4
	7	35	19.5	19.5	22.6	20.6	26.4	21.0
		69	23.7	22.8	28.9	23.9	35.0	24.5
		104	25.8	24.2	32.2	25.4	40.3	26.5
	8	35	18.4	18.4	21.3	19.9	24.8	20.4
		69	22.1	21.9	26.9	23.1	32.9	23.7
		104	24.0	23.1	30.0	24.5	37.8	25.6
9	35	17.4	17.4	20.0	19.2	23.4	19.8	
	69	20.6	20.6	24.9	22.2	30.8	22.9	
	104	22.1	22.0	27.8	23.5	35.3	24.7	

## 40LM040

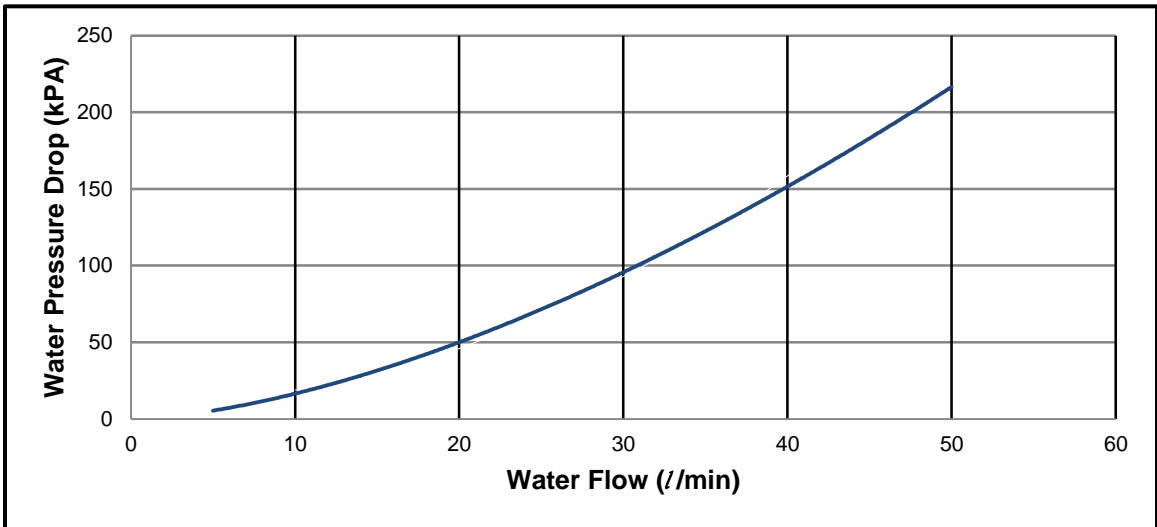

## 40LM050

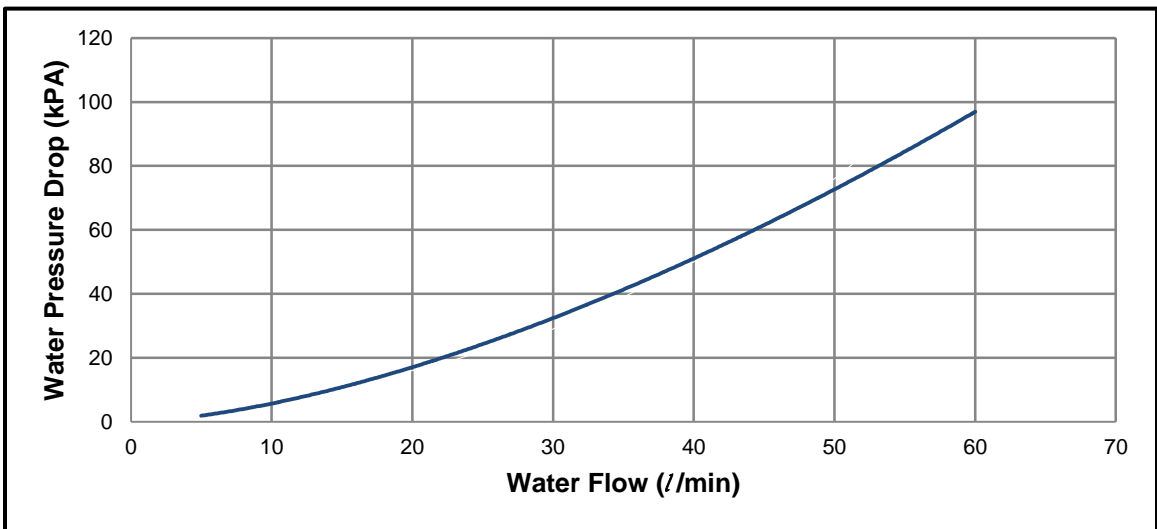

## 40LM060

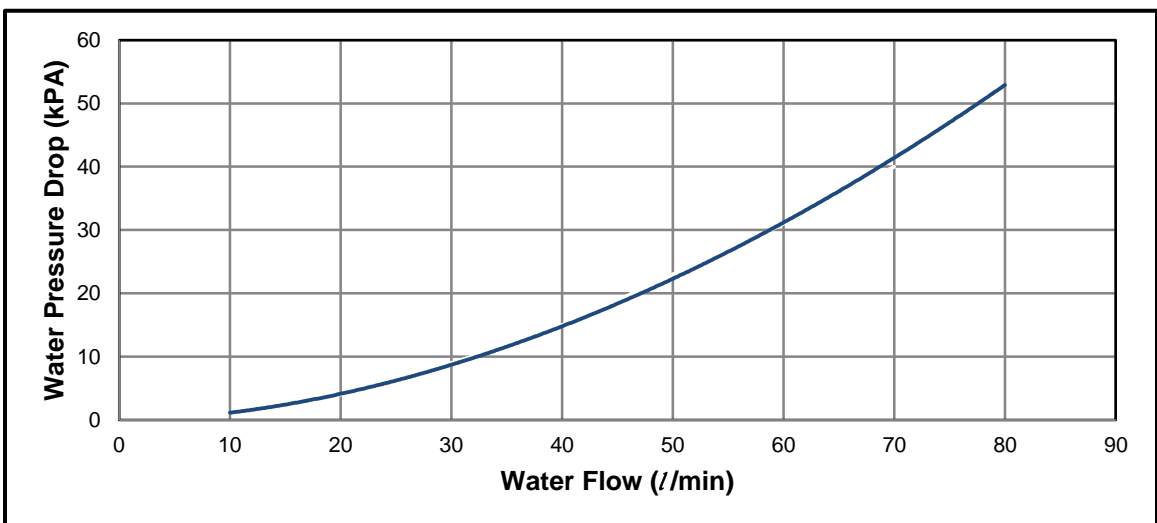



## 40LM070

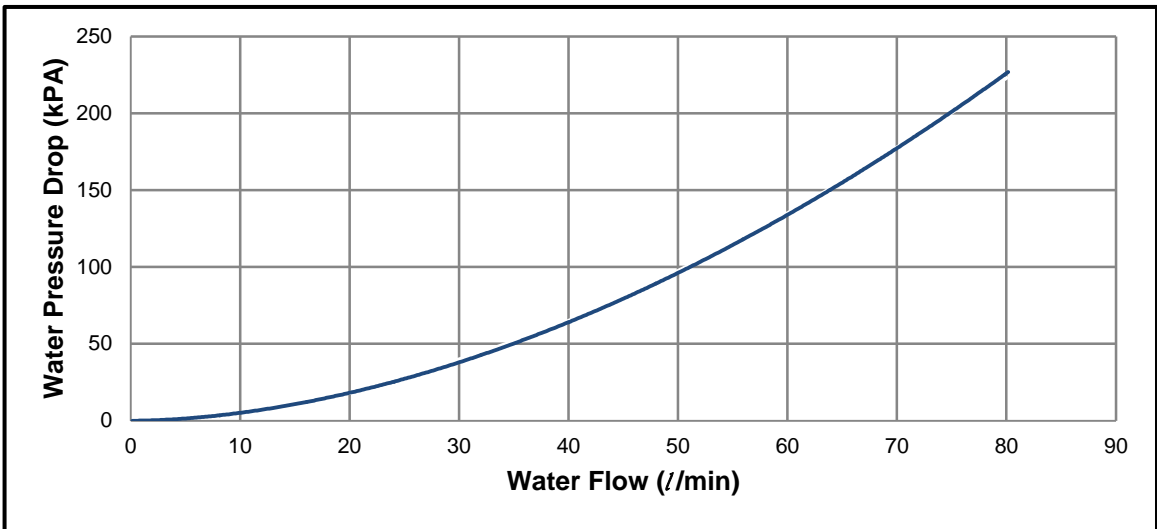

## 40LM090

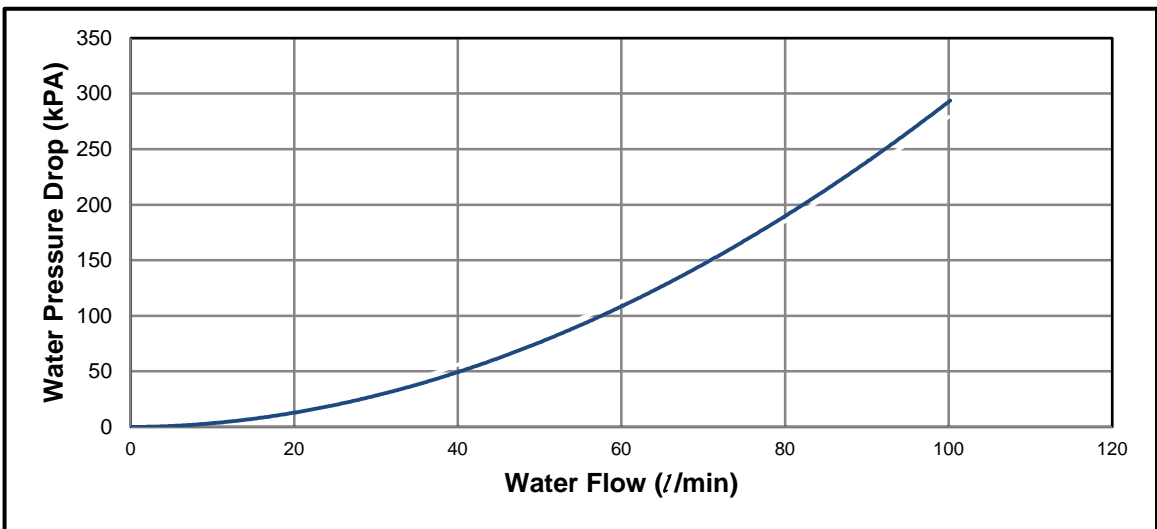

## 40LM100

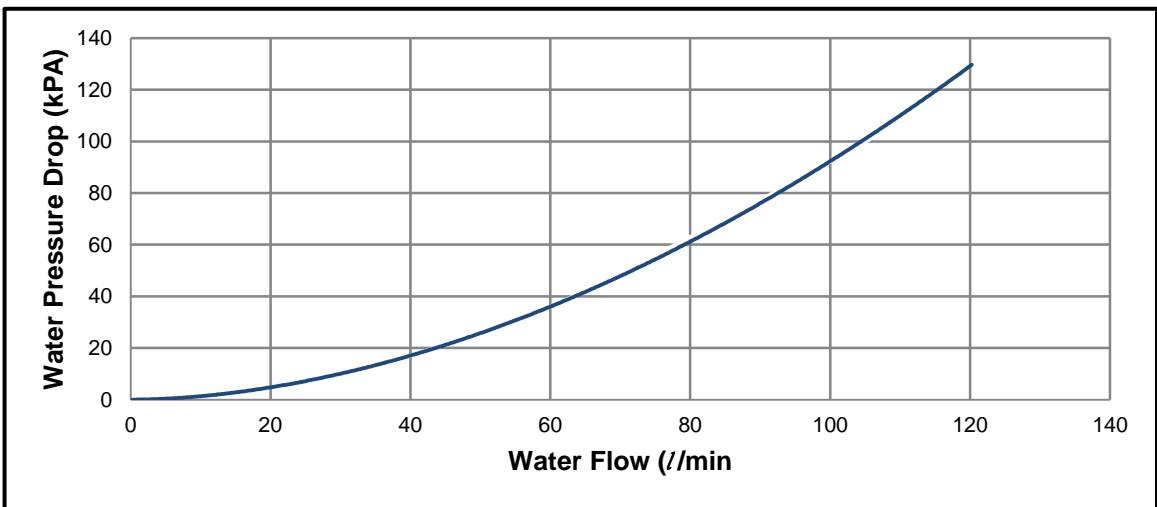

## 40LM040

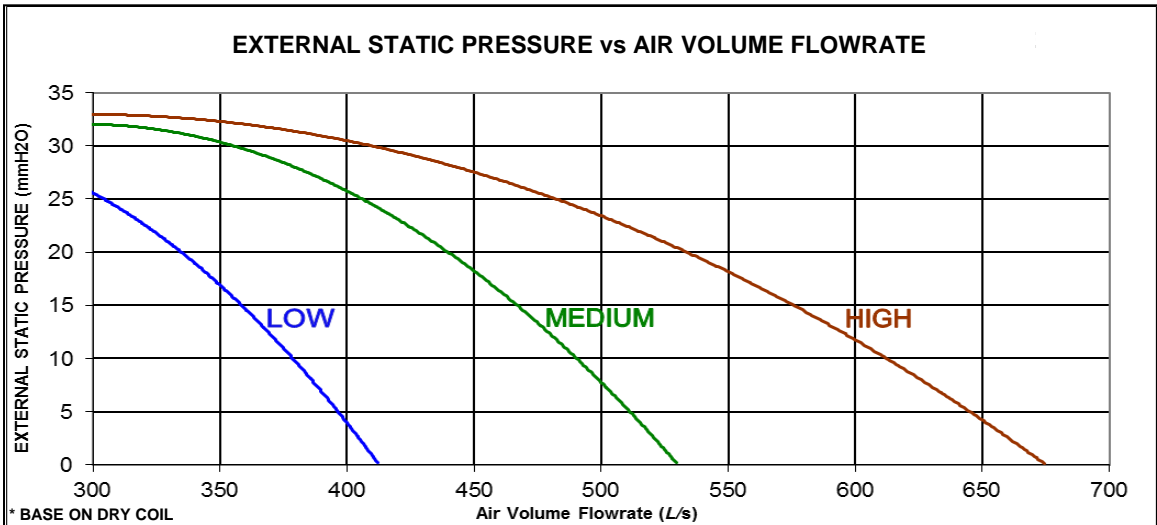

## 40LM050

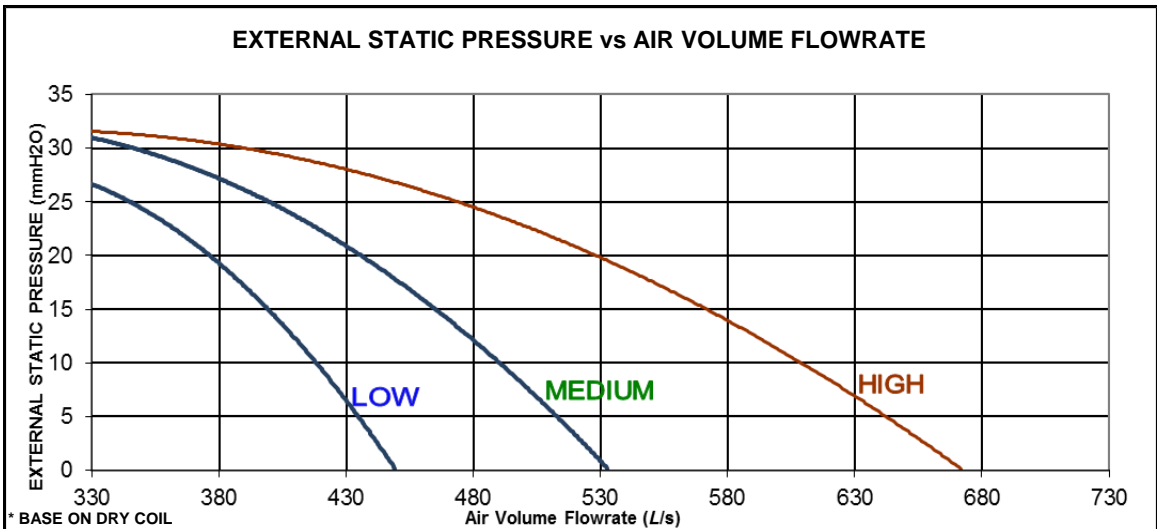

## 40LM060

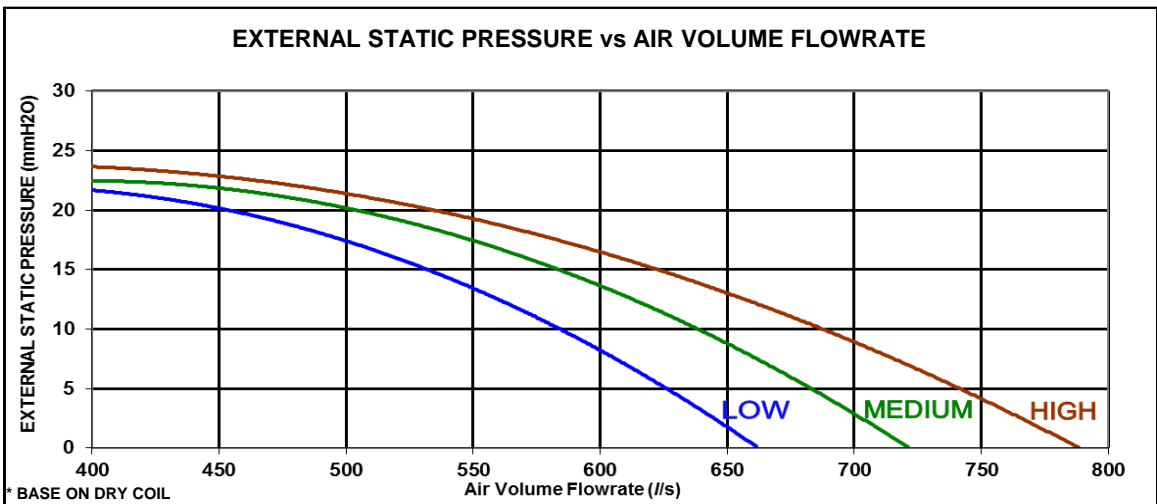

## 40LM070

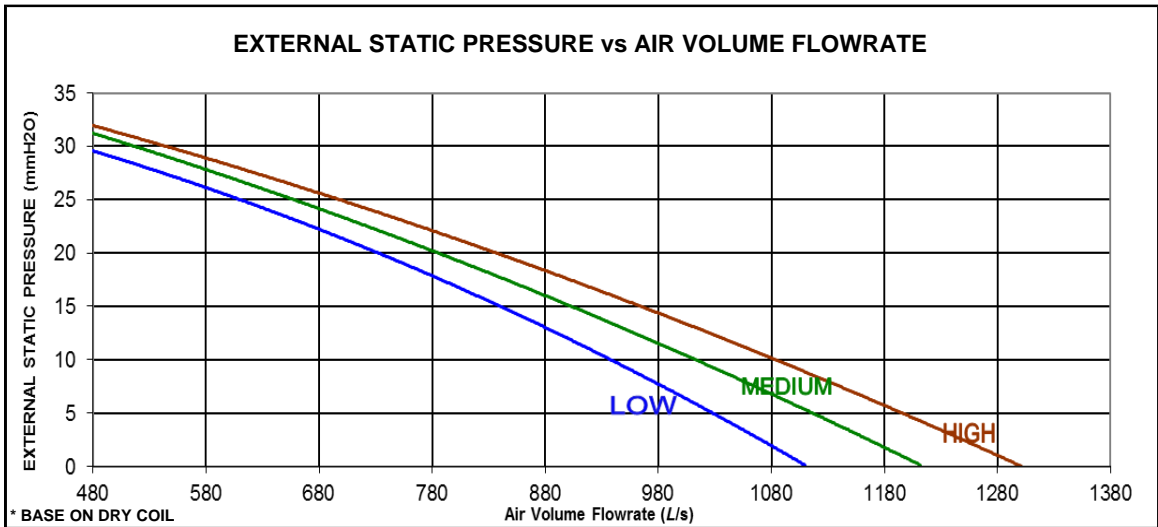

## 40LM090

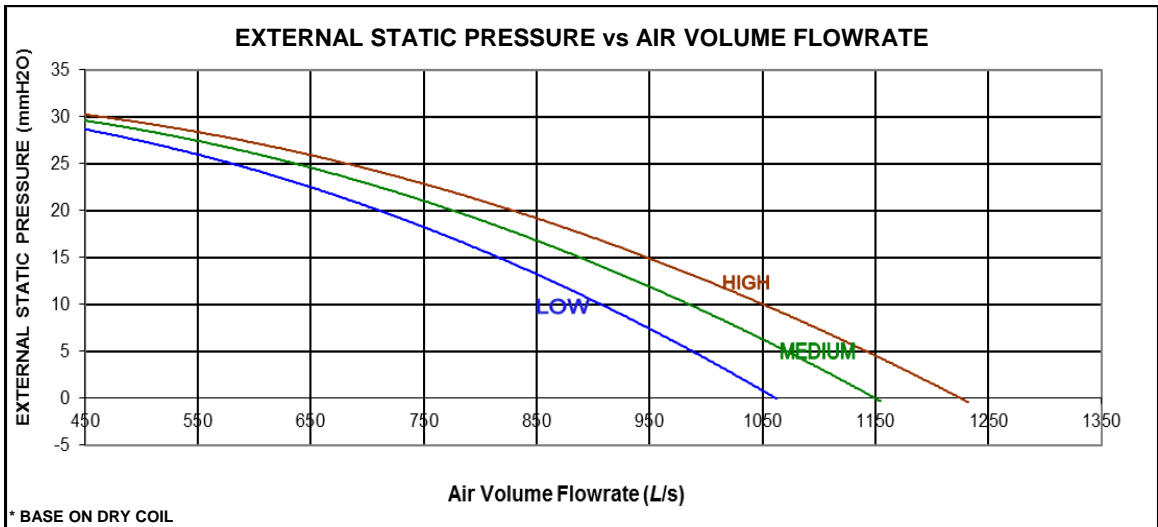

## 40LM100

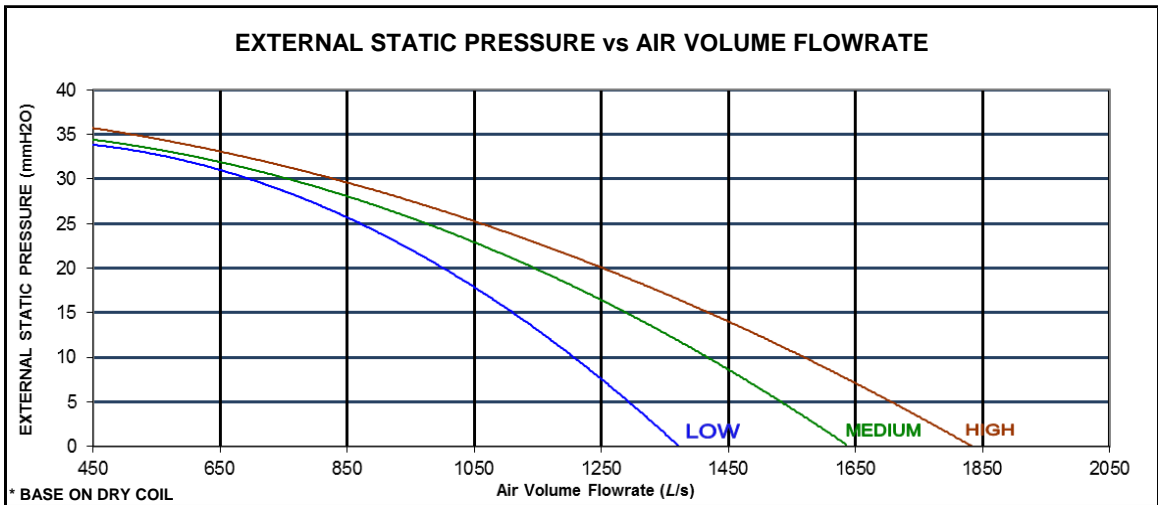

MODEL 40LM	SPEED	OCTAVE BAND CENTRE FREQUENCY, Hz								dB(A)
		63	125	250	500	1K	2K	4K	8K	
40	H	28	37	49	43	47	46	41	34	53
	M	24	32	41	39	43	39	33	23	47
	L	28	29	36	39	40	36	31	18	44
50	H	31	36	46	43	45	48	39	32	52
	M	29	33	40	38	41	40	33	24	47
	L	22	26	35	34	40	36	29	19	43
60	H	32	34	47	47	50	48	43	32	54
	M	27	30	42	42	47	45	39	28	51
	L	23	27	38	39	44	41	36	23	47
70	H	31	37	46	38	43	42	39	33	50
	M	29	34	43	35	41	39	36	29	47
	L	28	31	39	33	39	37	33	25	44
90	H	34	40	50	47	49	51	45	35	56
	M	30	36	47	44	46	48	41	30	53
	L	26	33	42	42	43	43	37	25	49
100	H	34	43	48	49	51	52	47	33	57
	M	33	40	45	47	48	49	42	30	54
	L	30	35	43	44	46	45	38	29	51

**Note:**

Sound measurement is accordance with standard JIS B8616-2006 (1.5 meter below the unit bottom) at 8mm ESP.

40LM040				
Speed	Nominal Power Output (Watts)	Power Input (Watts)	RPM	FLA (A)
High		805	1098	
Medium	315	587	1029	2.46
Low		474	930	

\*FLA: Full Load Amps

40LM050				
Speed	Nominal Power Output (Watts)	Power Input (Watts)	RPM	FLA (A)
High		764	1184	
Medium	315	600	1022	2.46
Low		475	912	

\*FLA: Full Load Amps

40LM060				
Speed	Nominal Power Output (Watts)	Power Input (Watts)	RPM	FLA (A)
High		679	1323	
Medium	462	617	1278	4.40
Low		563	1212	

\*FLA: Full Load Amps

40LM070				
Speed	Nominal Power Output (Watts)	Power Input (Watts)	RPM	FLA (A)
High		988	1380	
Medium	750	859	1348	4.55
Low		766	1300	

\*FLA: Full Load Amps

40LM090				
Speed	Nominal Power Output (Watts)	Power Input (Watts)	RPM	FLA (A)
High		1070	1372	
Medium	750	919	1326	4.55
Low		825	1272	

\*FLA: Full Load Amps

40LM100				
Speed	Nominal Power Output (Watts)	Power Input (Watts)	RPM	FLA (A)
High		1610	1334	
Medium	800	1290	1259	7.40
Low		1120	1169	

\*FLA: Full Load Amps

## Part 1 – GENERAL

### 1.1 System Description

Horizontal, furred-in, above ceiling for ducting room fan coil unit.

### 1.2 Quality Assurance

Unit shall be tested in accordance with ARI Standard 440. Each coil shall be factory tested for leakage at 400psig air pressure with coil submerged in water. Factory is ISO-9001 certified.

### 1.3 Delivery Storage and Handling

Each unit shall be individually packaged from point of manufacture. Units shall be handled and stored in accordance with the manufacturer's instructions.

## Part 2 – PRODUCTS

### Equipment

#### 2.1 General

Factory assembled, horizontal draw through type fan coil for furred-in ducted installations. Units shall be completed with water coil(s), fan(s), motor(s), drain pan, filters and all required wiring, collars for ducted units. Unit insulation and unit's drain pan insulation are UL94 compliance.

#### 2.2 40LM Furred-in Units

Base 40LM unit with factory installed plenum section and cleanable filter as shown on equipment drawings. The plenum shall be rear air return. Shall enclose the fan/motor assemblies, and shall be lined with 12.7mm thick PU insulation 18kg/m<sup>3</sup> density and 6.0mm PE insulation 33kg/m<sup>3</sup> density on the drain pan. Unit shall have a removable panel to provide access to fan/motor assemblies and unit identification label.

#### 2.3 40LM Horizontal Base Unit with Plenum for Concealed Installations

Unit has a factory installed, galvanized steel plenum section and one-in permanent filter. The plenum shall be rear return, lined with 12.7mm PU insulation 18kg/m<sup>3</sup> and 6.0mm PE insulation 33kg/m<sup>3</sup> on the drain pan, and include a removable panel to provide access to the fan/motor assembly.

#### 2.4 Fan

Direct driven, double width fan wheels with forward curved blades shall be statically and dynamically balanced. Fan wheels shall be constructed of high density reinforced polypropylene.

#### 2.5 Coils

Drain pan covers entire length and width of coil till the headers. Drain pan inside coated and outside insulated. Standard base unit shall be equipped with a 2,3 or 4-rows coil for installation in a 2-pipe system. Coils shall have 9.5mm copper tubes, aluminum fins bonded to the tubes by mechanical expansion. Each coil shall have a manual air vent and threaded connections field piping. Working pressure 1.72 Mpa, 0.105mm fin thickness and 0.24mm tube wall thickness.

#### 2.6 Operating Characteristics

A one coil unit installed in a 2-pipe system shall be capable of providing cooling as determined by the operating mode of the central water supply system.

#### 2.7 Electrical Requirements

Standard unit shall operate on 230V±10%, single phase, 50Hz electric supply.

#### 2.8 Motor(s)

Fan motors shall be 3-speed, 230V, single phase, 50Hz permanent split capacitor type, with ball type bearings and over-sized oil reservoirs to ensure lubrication. The fan motor(s) shall be equipped with integral automatic temperature reset for motor protection. Motor insulation is Class B with IP20 Ingress Protection.

#### 2.9 Filter

Permanent washable synthetic media filters with 12mm thick and G2 filter class as per European Union EN779.



**Carrier International Sdn. Bhd. (3385-T)**  
Lot 4, Jalan P/6, 43650 Bandar Baru Bangi,  
Selangor Darul Ehsan, Malaysia.  
Tel: 03-8913 7600

---

**40LM1**

**REV-6**

---

**01**

**2015**

---

*The Manufacturer reserves the right to change any product specifications without prior notices  
© All Rights Reserved Carrier*

40LM1-A15-7PD SUPERCEDES 40LM-A13-6PD

**40LM1-A15-7PD**