

Motorized Curtain Track

Progress 25/50



- Motorized curtain track with ultra-quiet operation.
- Automatically identifies and set Open and Stop operation limits.
- Manual-override (by hand-draw operation) is possible.
- FM remote control is available.
- Enables opening/closing of curtains without using any switch operations. (Touch Motion)

Progress 25/50's Unique Features

Feature 1: Quiet operation with a new motor and new rollers

The new motor and rollers provide ultra-quiet operation.

Feature 2: Can be curved into a variety of shapes

L-shaped, U-shaped, S-shaped and gradual curves.

Feature 3: Hand-draw operation as well as motor operation

A built-in electromagnetic clutch allows the drapery to be drawn by hand.

Feature 4: Highly durable belt drive transmission system

The belt drive transmission system is highly durable.

Feature 5: "Slow start" and "slow stop" functions

These functions enable the smooth start and stop of drapery operation.

Feature 6: Adjustable curtain open/close speed

The speed of operation is adjustable in 10 stages (from 4.5 to 9.5 seconds per meter). This allows you to select the speed that best matches each window.

Feature 7: Touch motion function

The touch motion function can perform opening/closing of curtains without using any switch.

If curtain is drawn, it will begin to move in the direction itself, and will stop at the place on limit setup.

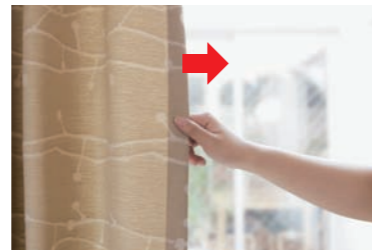

Product Overall View and Names of Parts

Progress 25/50

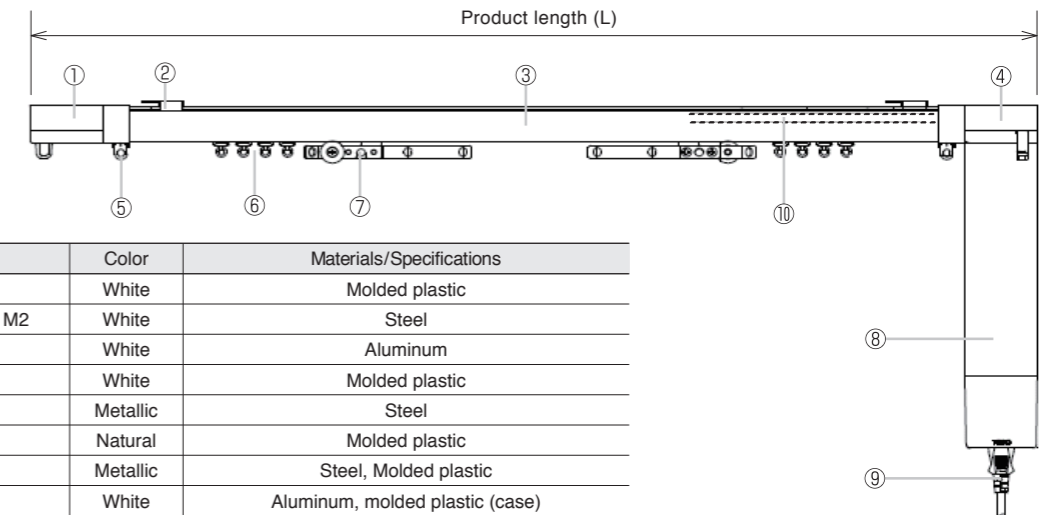

No.	Product Name	Color	Materials/Specifications
①	End side Pulley	White	Molded plastic
②	Ceiling Single Bracket M2	White	Steel
③	Track	White	Aluminum
④	Motor side Pulley	White	Molded plastic
⑤	Stop	Metallic	Steel
⑥	Noiseless Roller	Natural	Molded plastic
⑦	Pilot Roller Set	Metallic	Steel, Molded plastic
⑧	Motor	White	Aluminum, molded plastic (case)
⑨	Electric Cord with the ground	White	Wire with plug (1 m/39")
⑩	Drive Belt	Green	3-layer structure of steel wires, plastic and fiber

Rail Cross Section

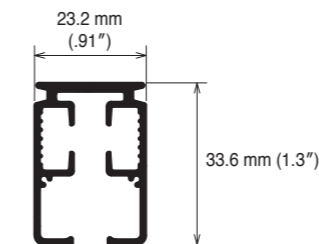

Installation Dimensions

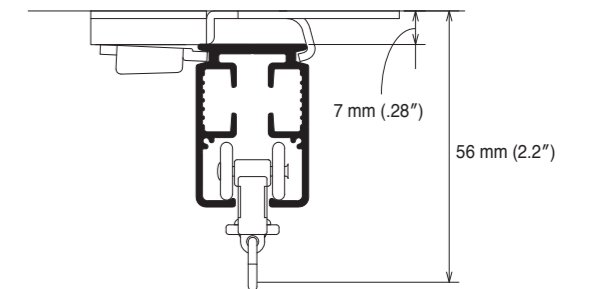





Motor Specifications

	Progress 25	Progress 50
Rated power voltage	AC 100 to 240 V	
Rated power frequency	50/60 Hz	
Power consumption	During stand by: 15 W or lower Max. load operation: 86 W	
Operating voltage	DC 24 V	
Operating current	3 mA	
Operating speed	5 to 10 sec./m (variable in 10 stages)	4.5 to 9.5 sec./m (variable in 10 stages)
Rated current	0.59 N.m	0.98 N.m
Ambient temperature	0 to 50°C (non-condensing)	
Time rating	5 min. (continuous operation)	

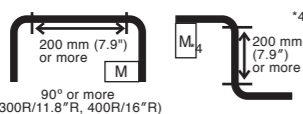

Applicable Range

Specifications			Progress 25		Progress 50	
			Curtain Weight ^{*5}	Product Length	Curtain Weight ^{*5}	Product Length
Straight		One-way Draw	25 kg (55 lb)	1,000 mm (39") to 10,000 mm (394")	50 kg (110 lb)	1,000 mm (39") to 10,000 mm (394")
		Two-way Draw	25 kg (55 lb) [One-way Draw: 12 kg (26.4 lb)]		50 kg (110 lb) [One-way Draw: 25 kg (55 lb)]	
Single ^{*1} Curve	 90° or more (300R/11.8"R, 400R/16"R)	One-way Draw	15 kg (33 lb)	1,200 mm (47") to 10,000 mm (394")	35 kg (77 lb)	1,200 mm (47") to 10,000 mm (394")
		Two-way Draw	15 kg (33 lb) [One-way Draw: 7 kg (15.4 lb)]		35 kg (77 lb) [One-way Draw: 17 kg (37.5 lb)]	
Two Curves ^{*2} (U-shaped or S-shaped)	 200 mm (7.9") or more 90° or more (300R/11.8"R, 400R/16"R)	One-way Draw	15 kg (33 lb)	1,500 mm (59") to 6,000 mm (236")	25 kg (55 lb)	1,500 mm (59") to 10,000 mm (394")
		Two-way Draw	15 kg (33 lb) [One-way Draw: 7 kg (15.4 lb)]		25 kg (55 lb) [One-way Draw: 12 kg (26.5 lb)]	
Overall Curve Half ^{*3}	 1,000R (39"R) or more	One-way Draw	15 kg (33 lb)	1,000 mm (39") to 6,000 mm (236")	25 kg (55 lb)	1,000 mm (39") to 7,000 mm (276")
		Two-way Draw	15 kg (33 lb) [One-way Draw: 7 kg (15.4 lb)]		25 kg (55 lb) [One-way Draw: 12 kg (26.5 lb)]	

^{*1} With regular curve radius of 300R (11.8"R) or 400R (16"R), curve bending is available in the range of 90° to 179°.
^{*2} With regular curve radius of 300R (11.8"R) or 400R (16"R), curve bending is available in the range of 90° to 179°.
^{*3} Overall curve half is available with a curve radius of 1,000R (39"R) or more. The number of splice is one piece only, and two tracks need to be spliced in the center.
^{*4} A splice between two curves requires at least 400 mm (16") of a straight portion, and a non-splice between two curves requires at least 200 mm (7.9") of a straight portion.
^{*5} An allowable curtain load per roller is 1.5 kg (3.3 lb) or less.

Product Size (Pilot Roller with Arm)

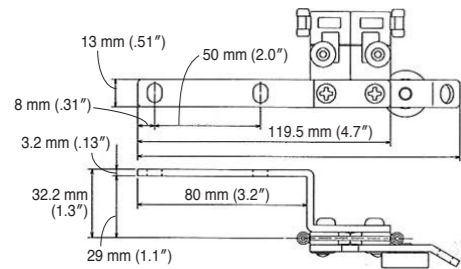

Installation Dimensions and Diagram

One-way draw: ceiling single attachment

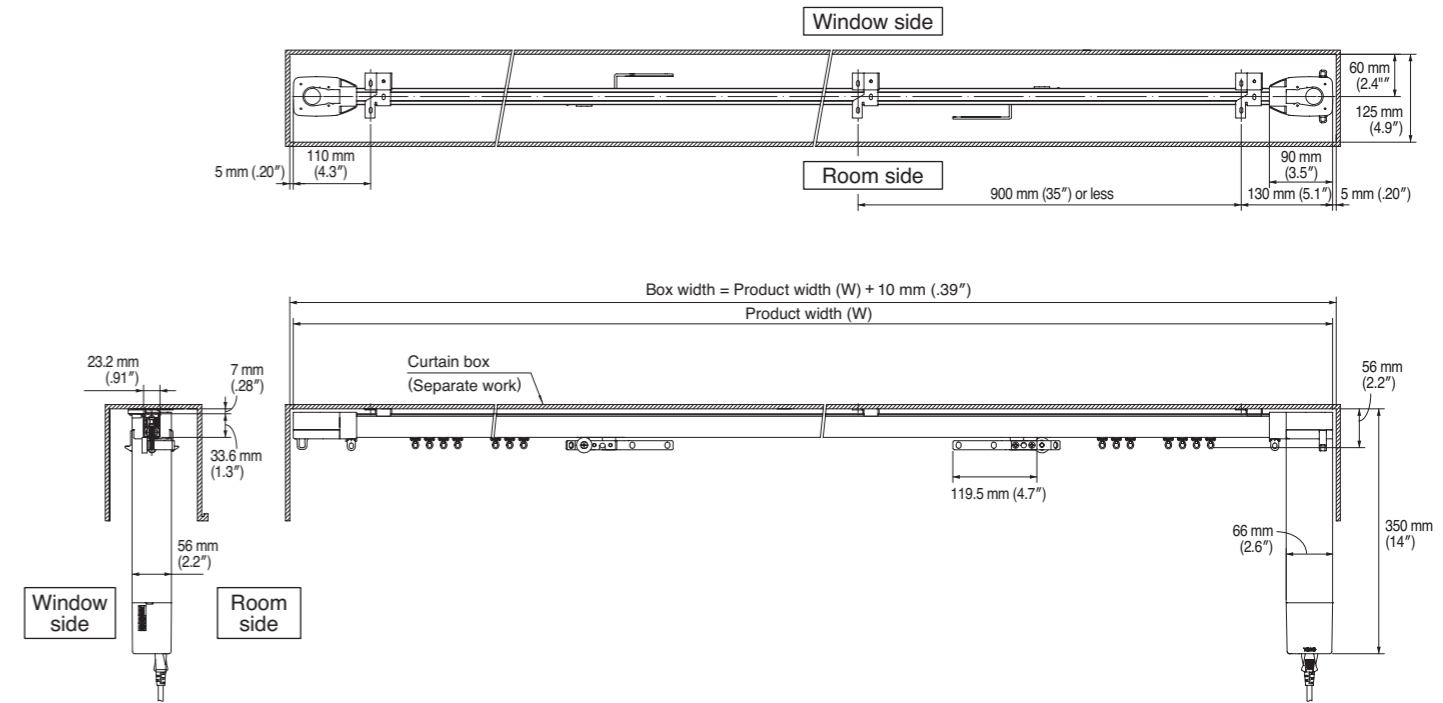

Two-way draw: ceiling double attachment

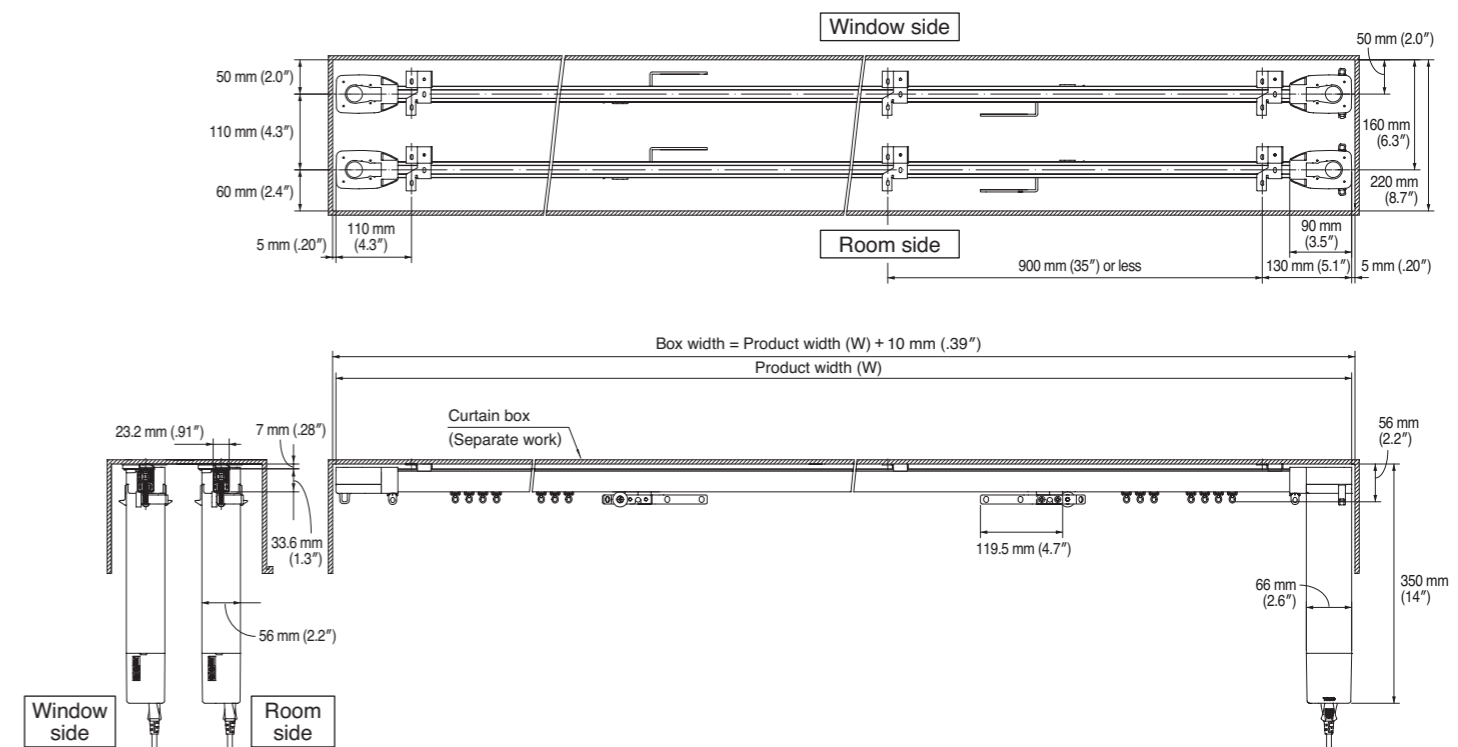

Two-way draw: ceiling single attachment
(Overlap rail)

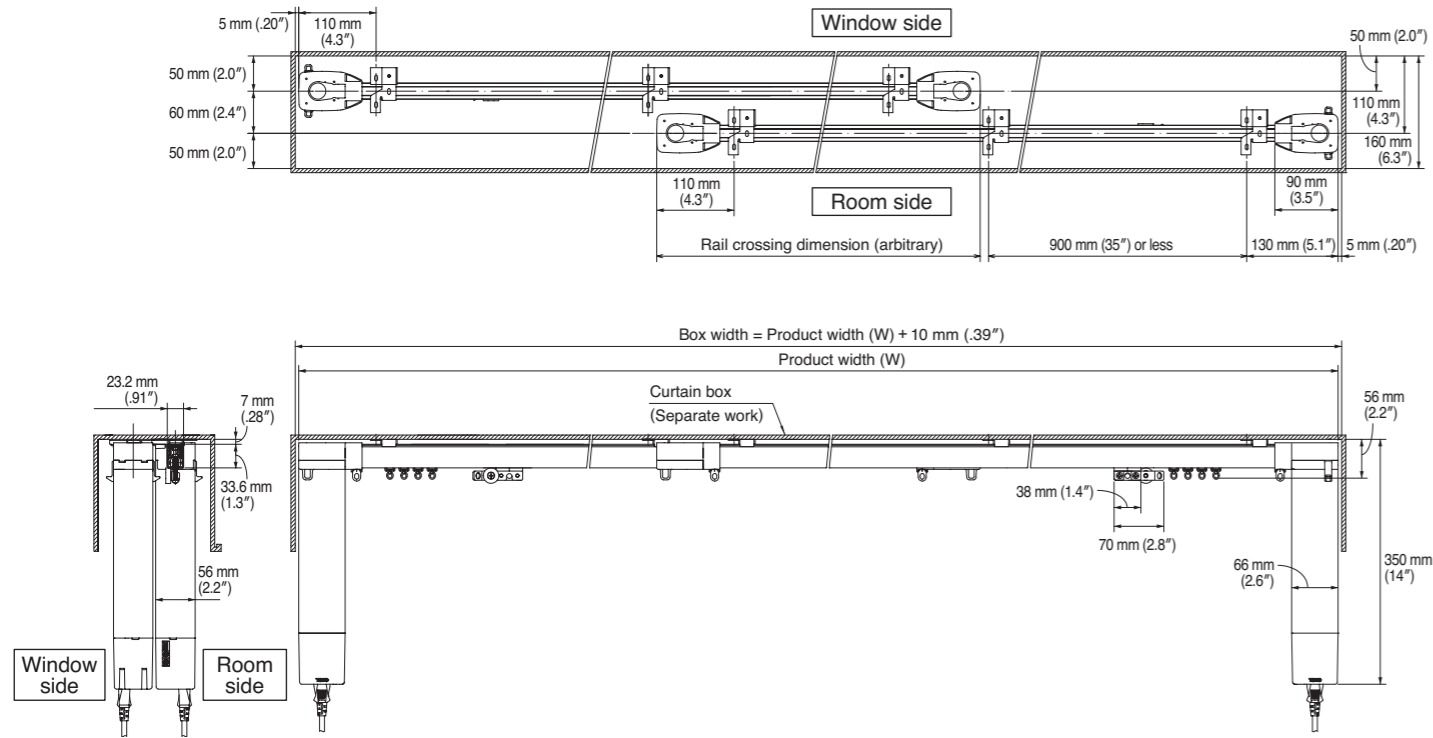

Single curve: ceiling single attachment

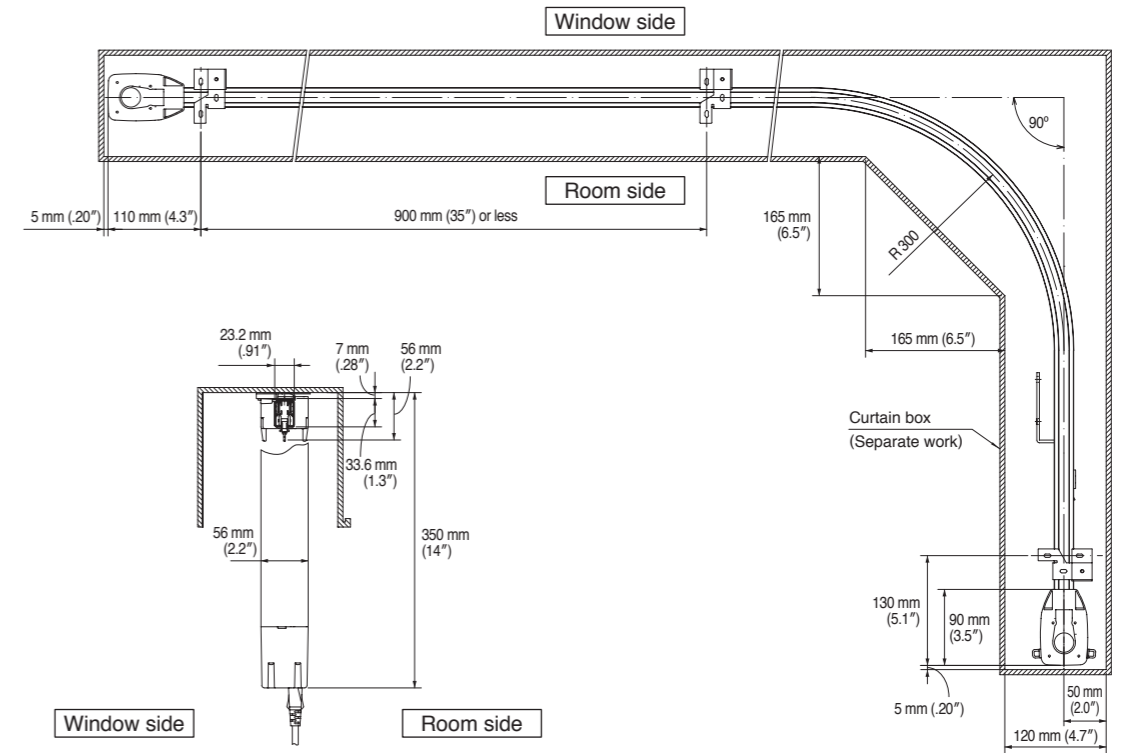

Two-way draw: ceiling double attachment
(Room side: Overlap with two rails, Window side: Master roller)

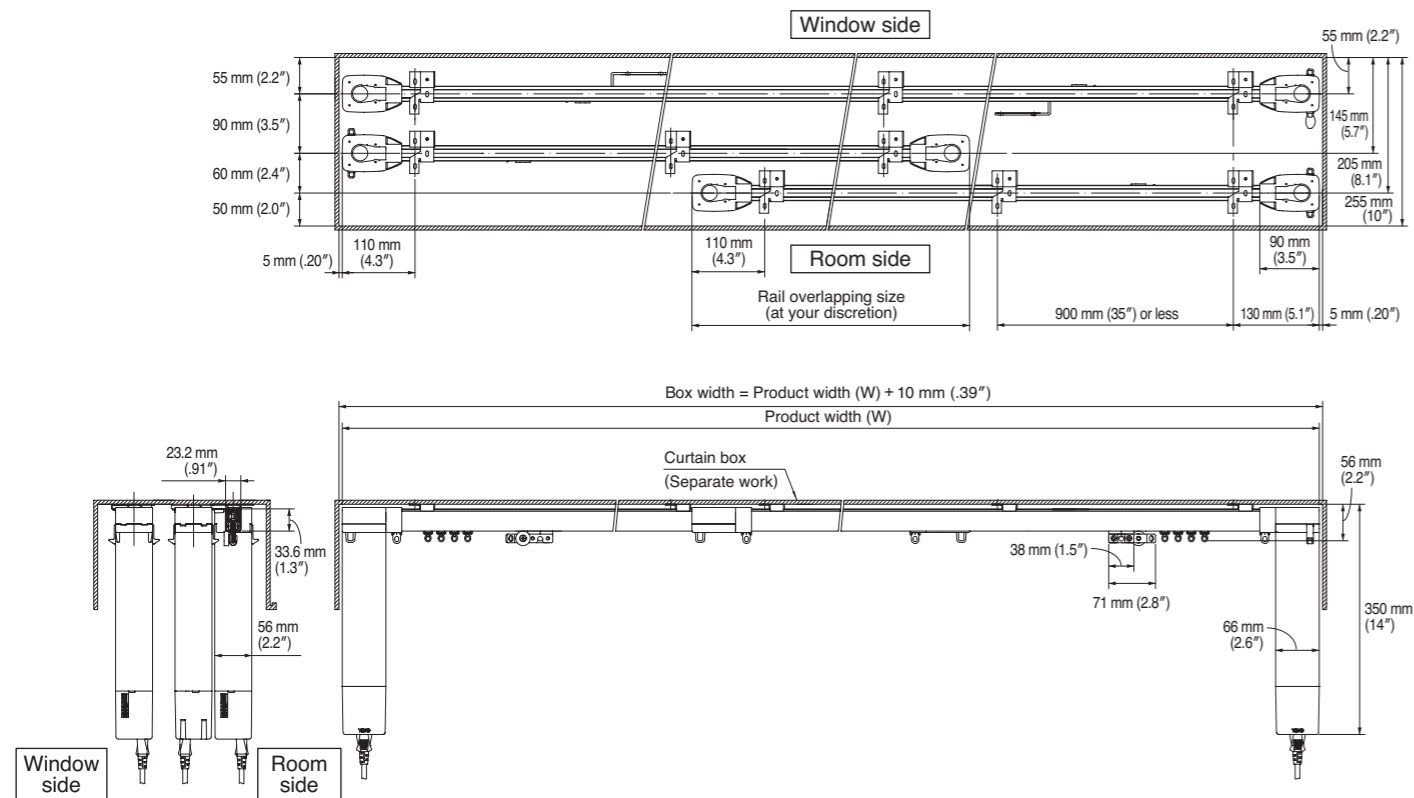

Single curve: ceiling double attachment

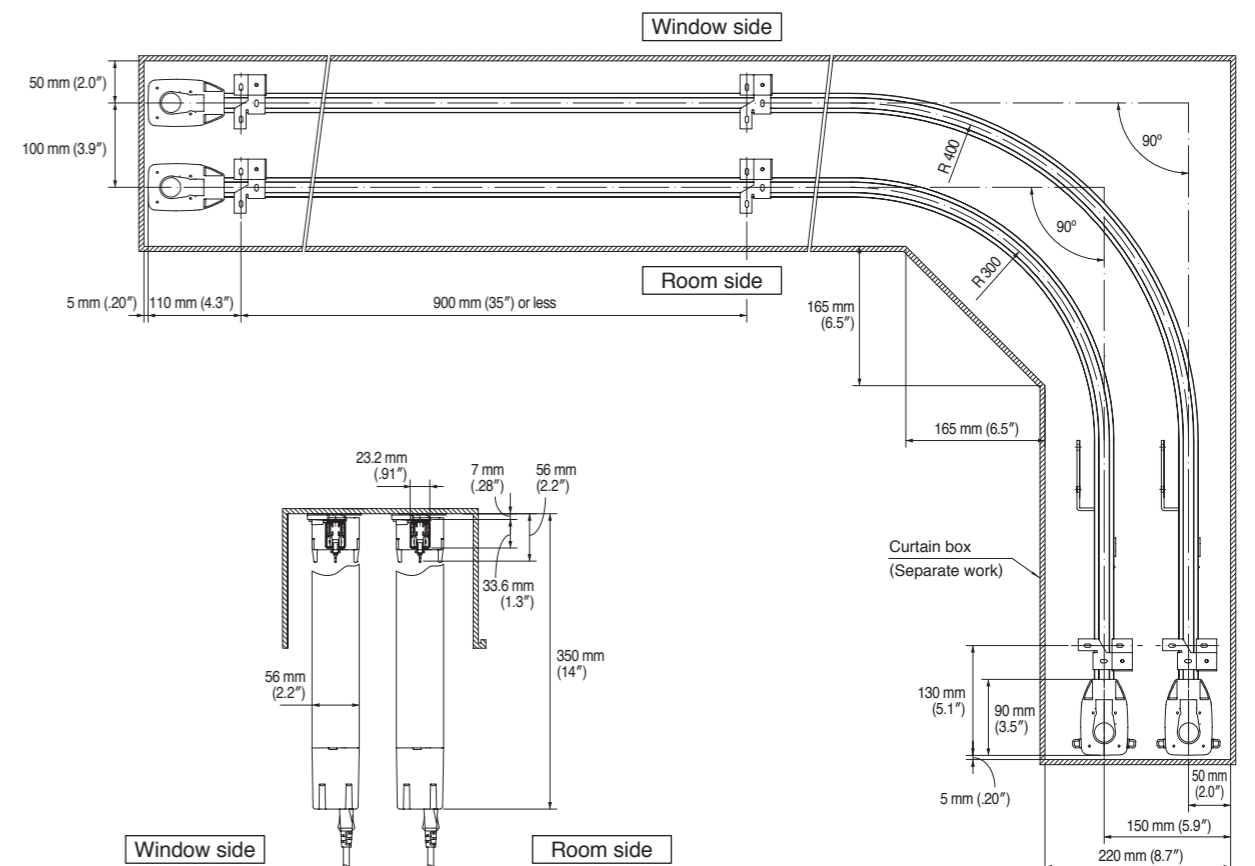

Two curves: ceiling single attachment

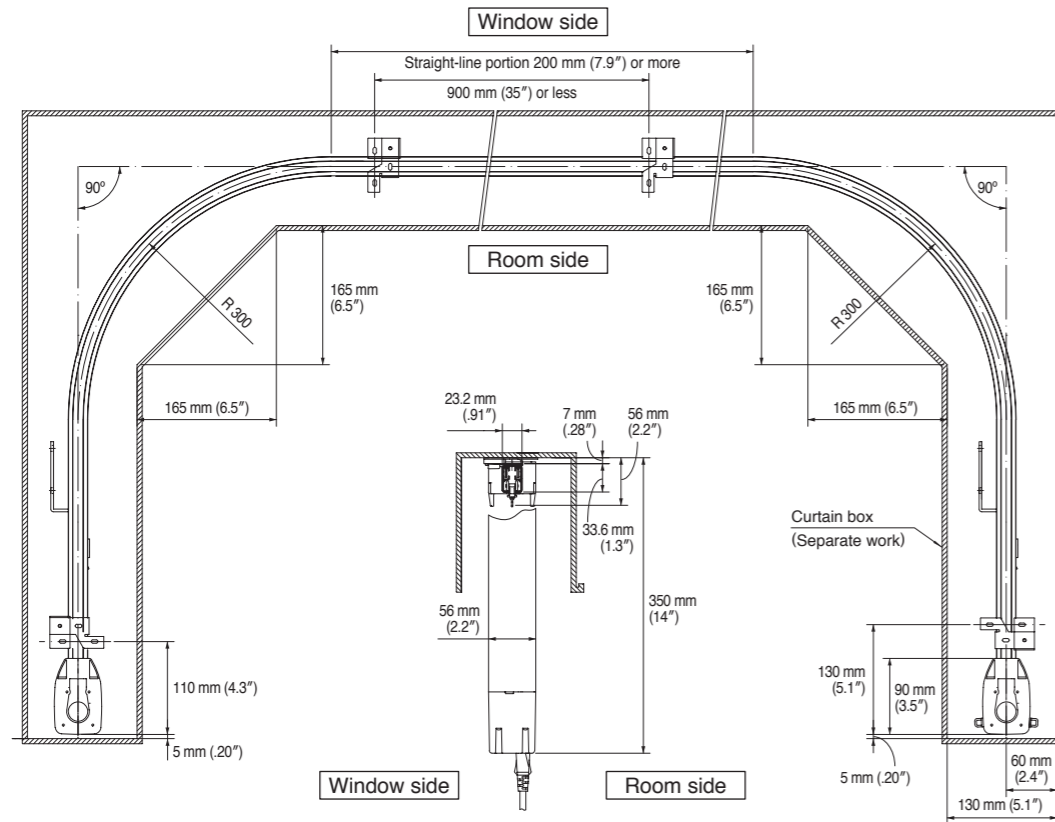

Two curves (S-shaped): ceiling single attachment

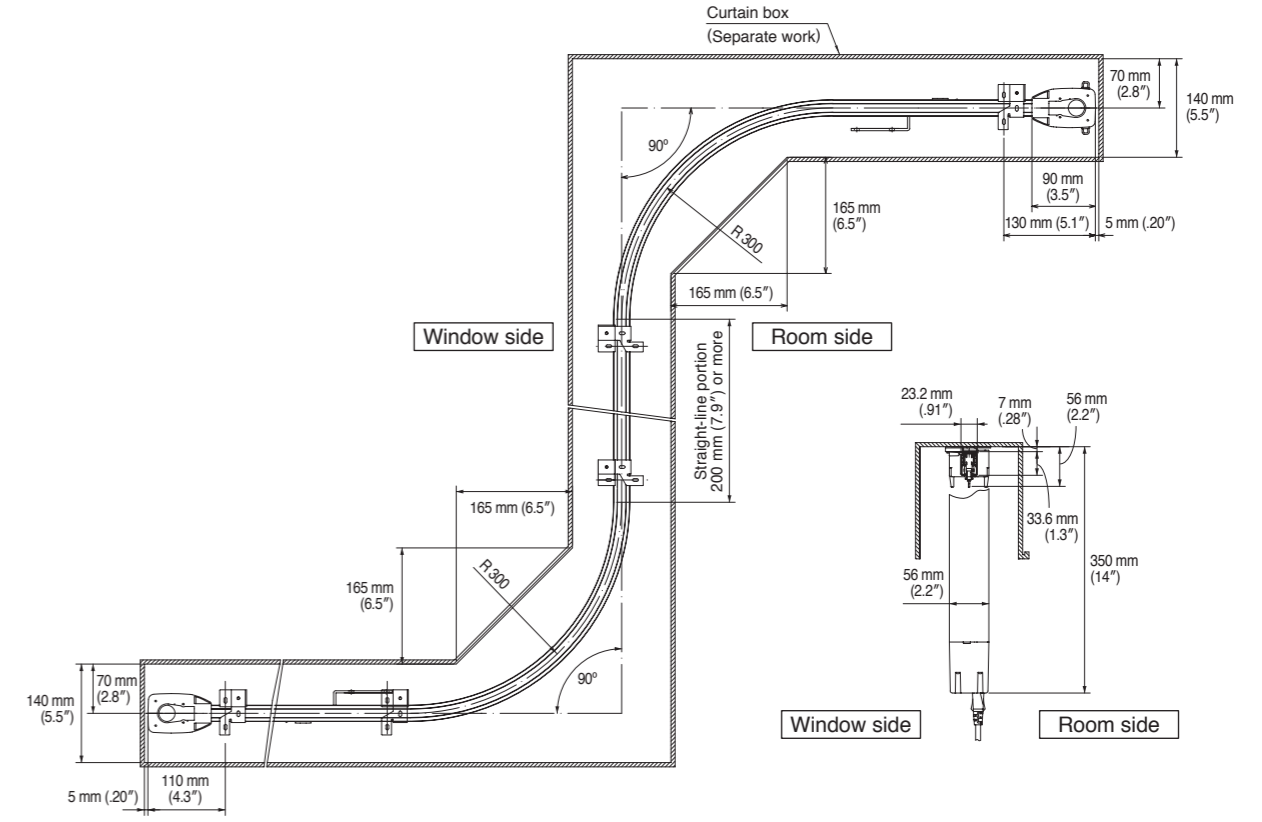

Two curves: ceiling single attachment
(Room side: Overlap with two rails, Window side: Master roller)

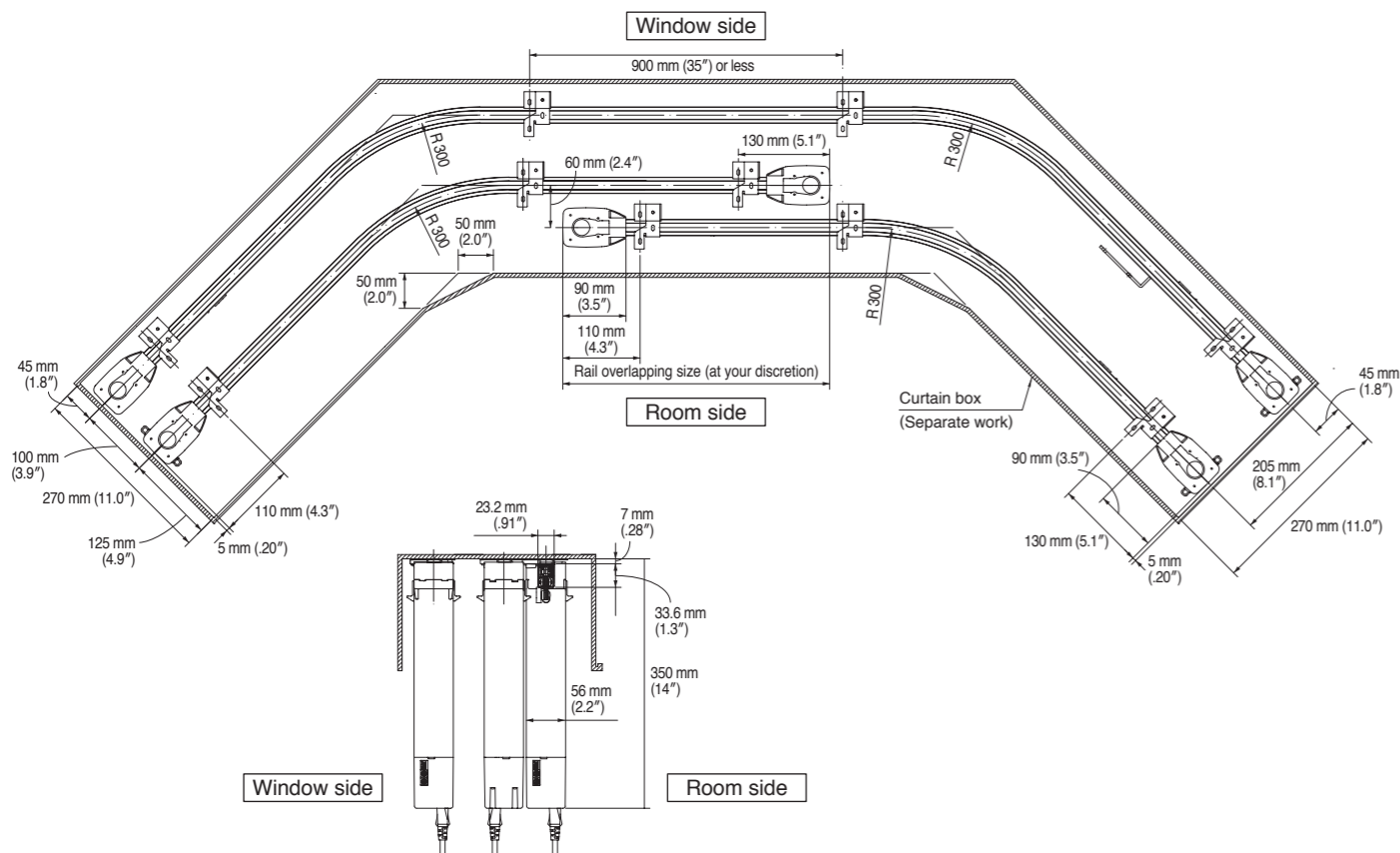

Gradual curve: ceiling single attachment

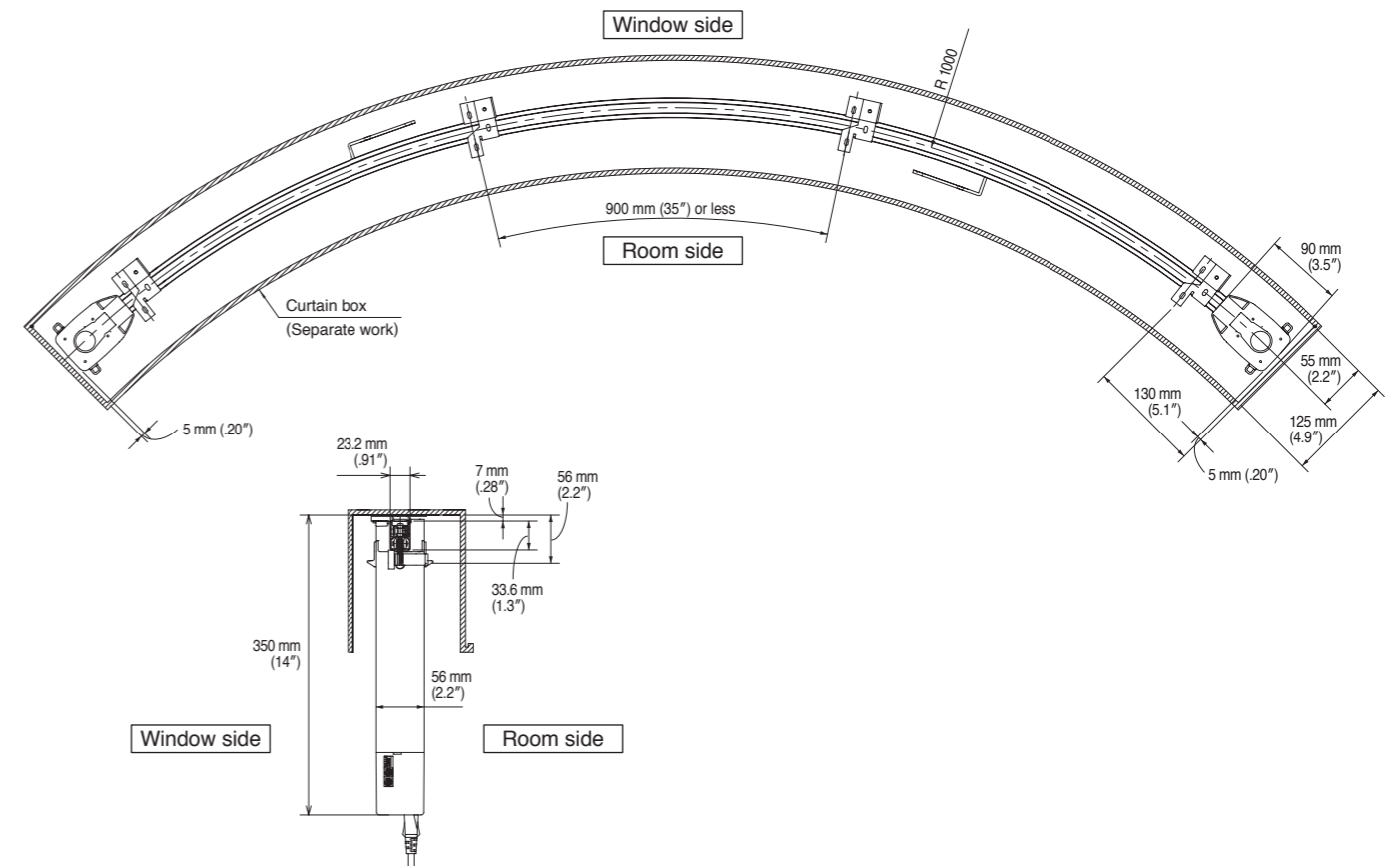

Overall curve half: ceiling double attachment
 (Room side: Overlap with two rails, Window side: Master roller)

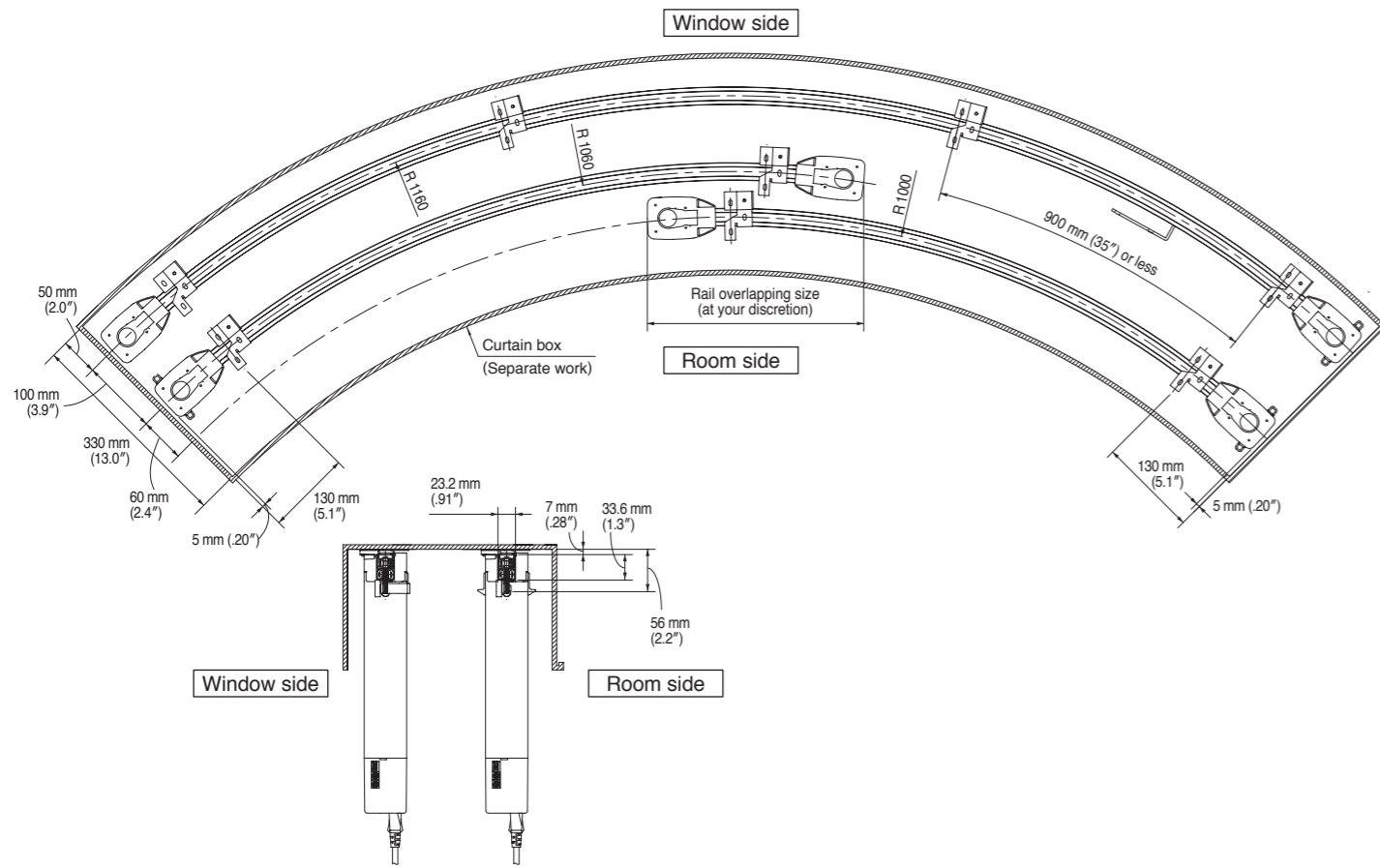

Basic Wiring and Connecting Diagram

Single Operation

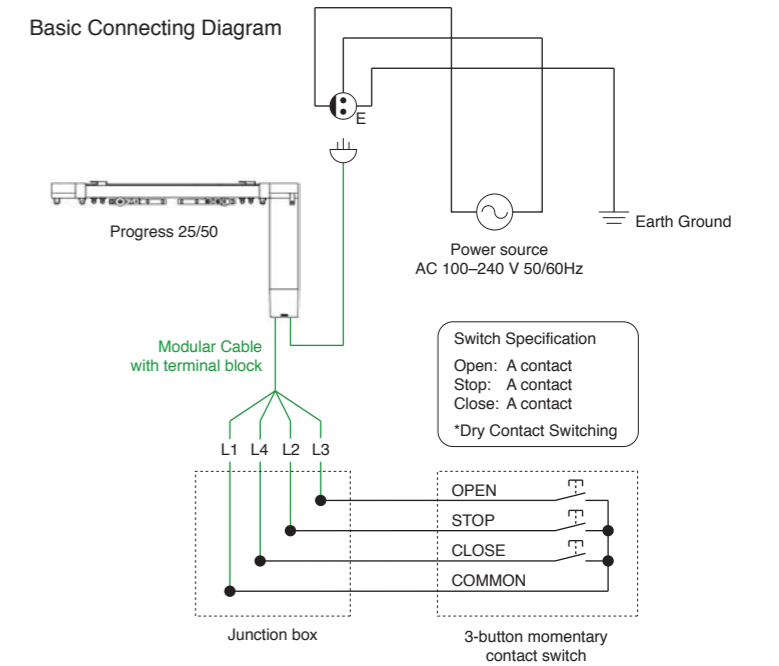
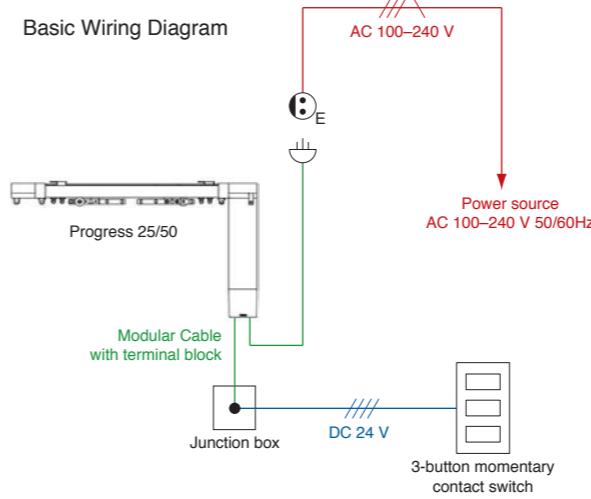

Operation from Two Locations

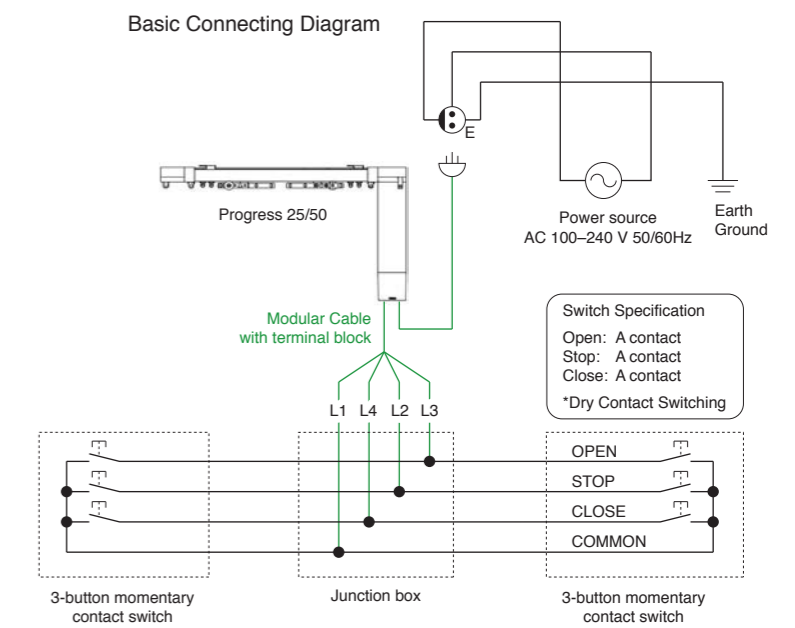
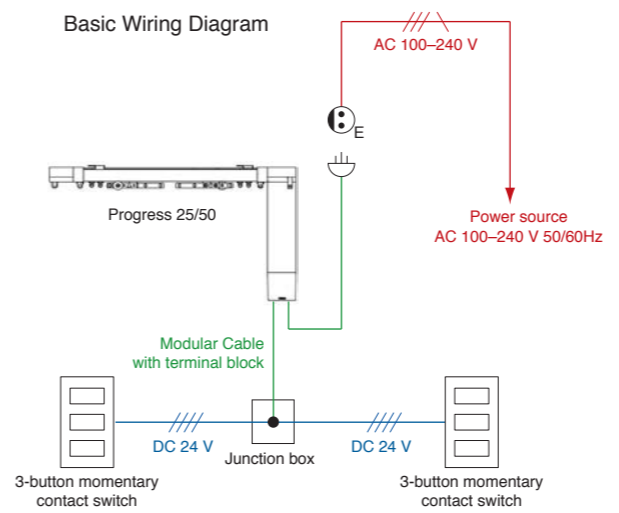

Explanatory notes: — Power supply, — Low voltage control line, — Main body attachment or TOSO standard

Simultaneous Operation

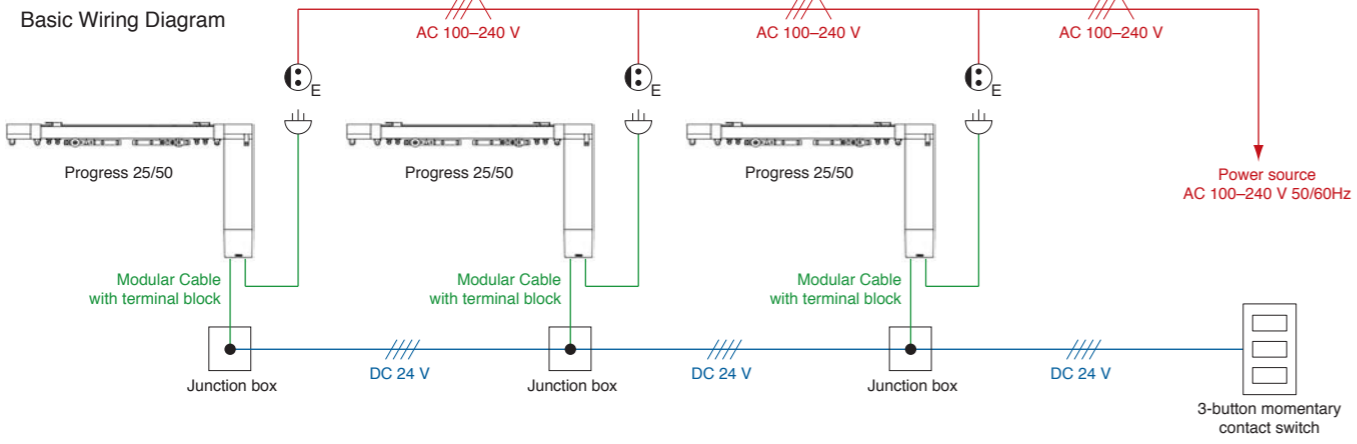

Basic Connecting Diagram

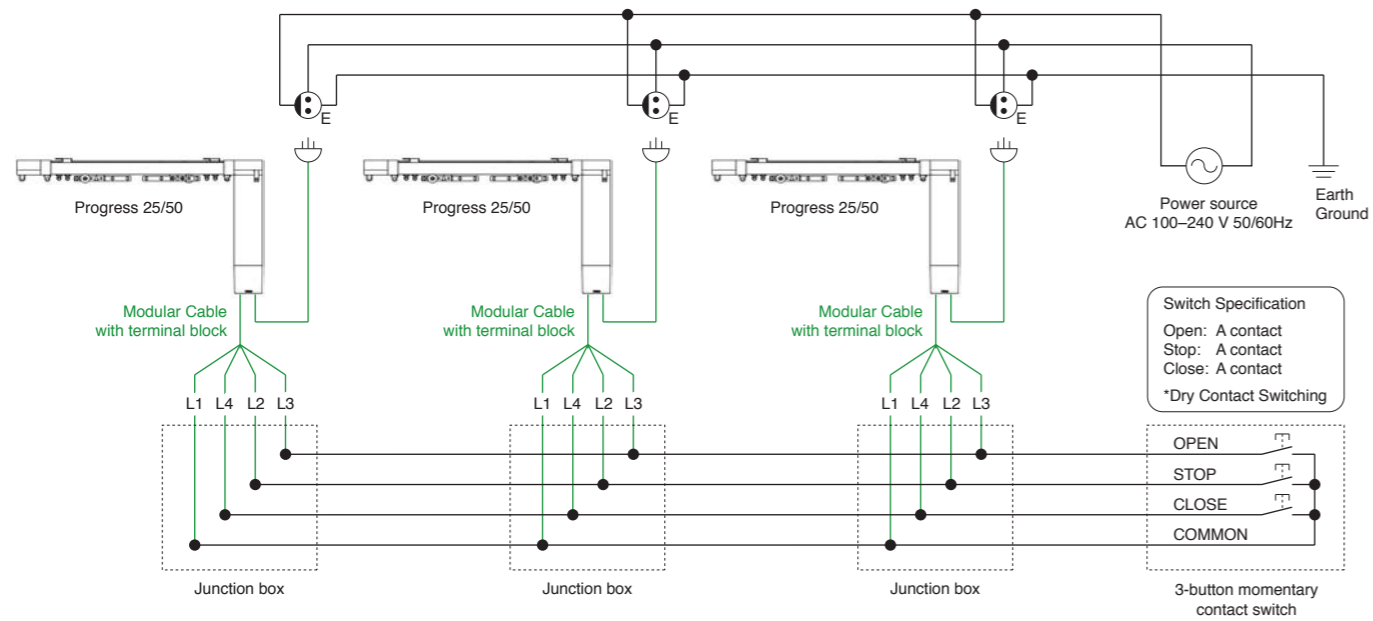

Simultaneous Operation for Select

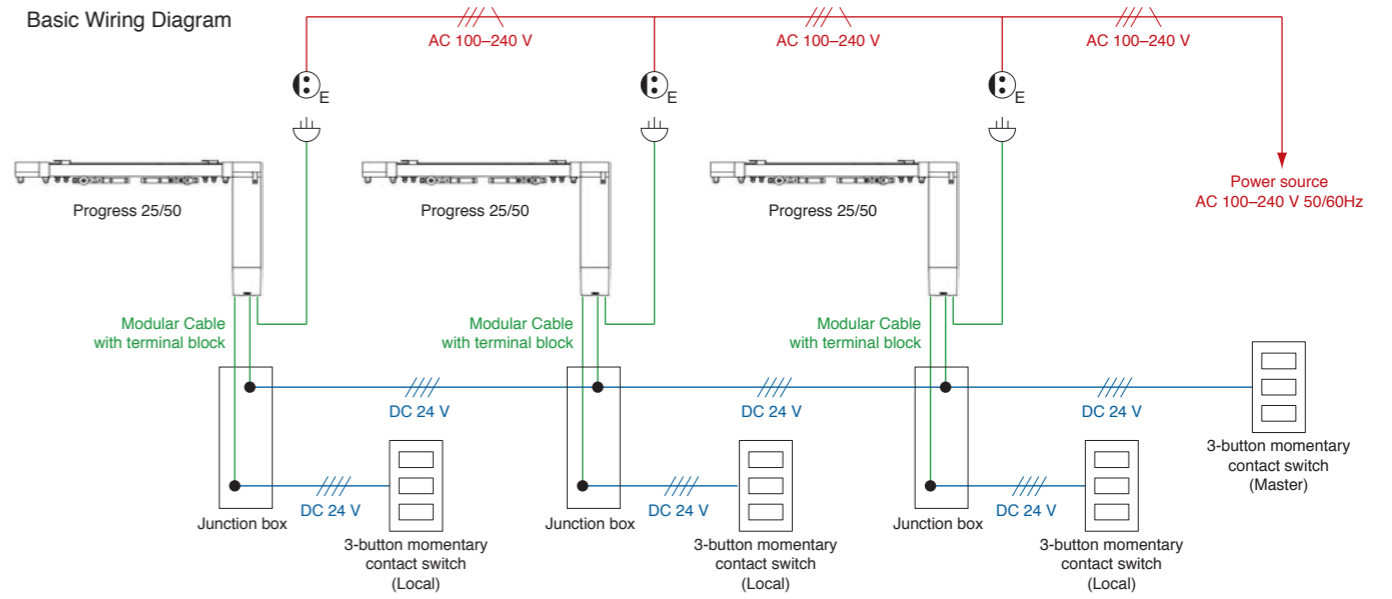

Basic Connecting Diagram

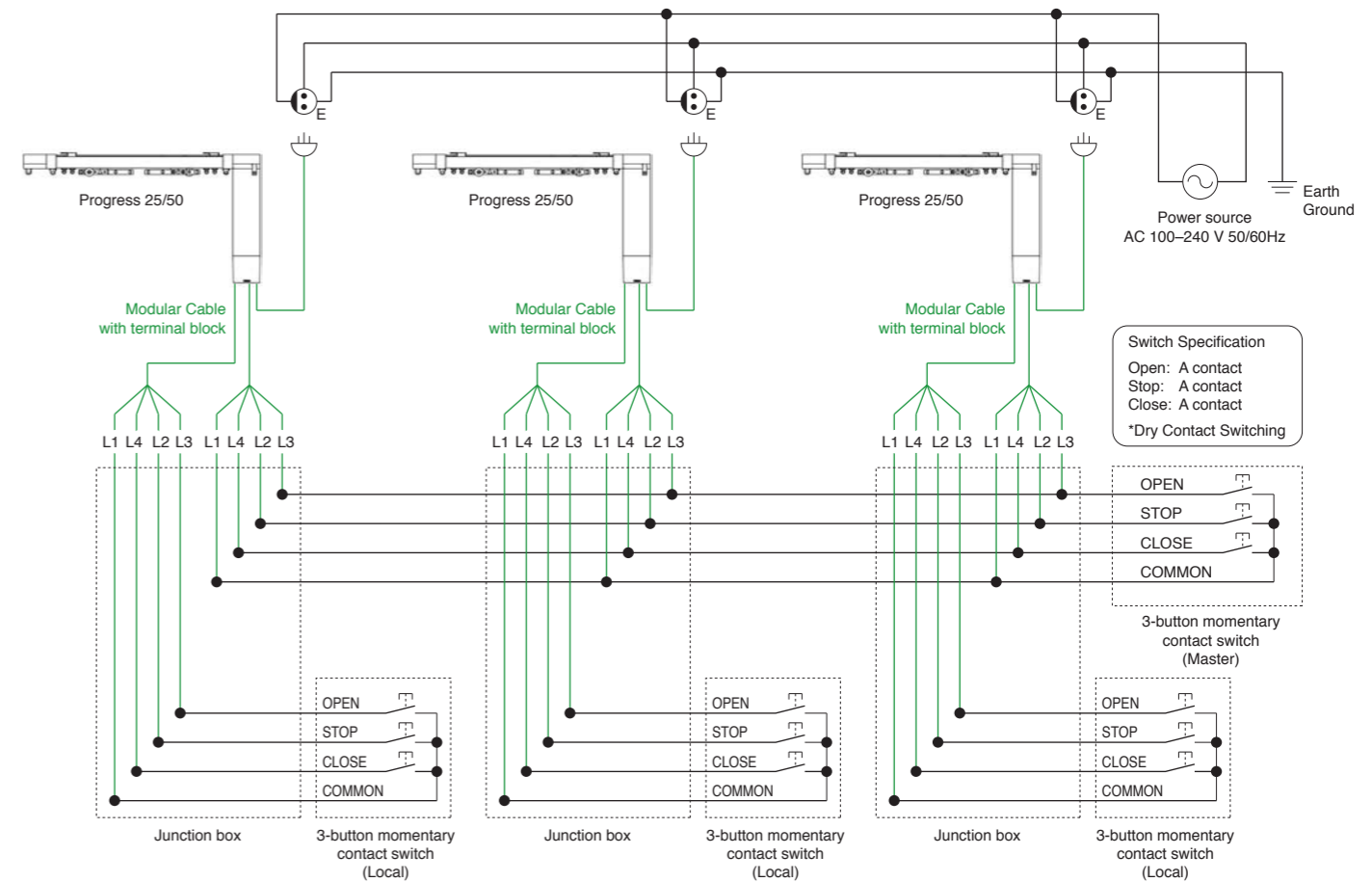

Explanatory notes: — Power supply, — Low voltage control line, — Main body attachment or TOSO standard

Infra-red Operations

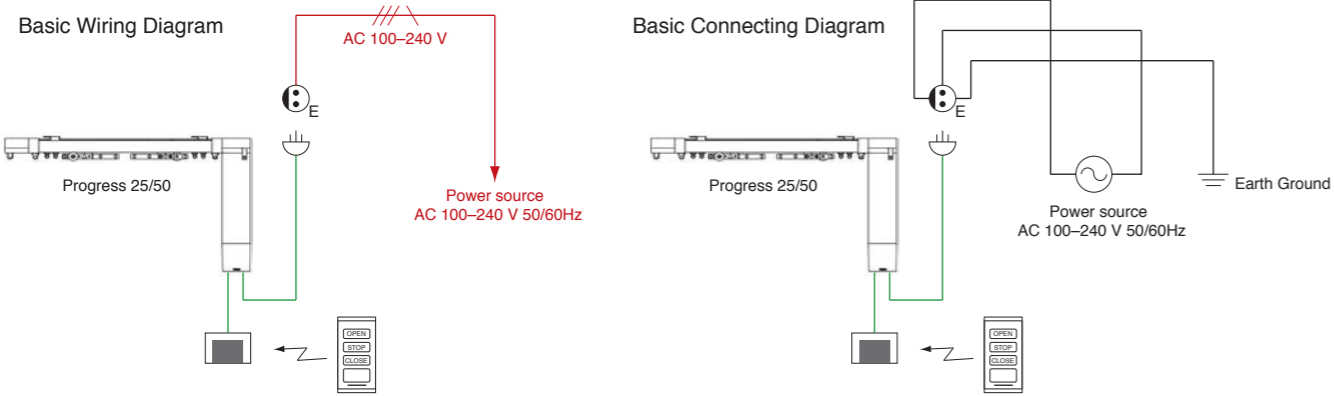

FM Remote-Control Receiver 2.4G with IR Terminal

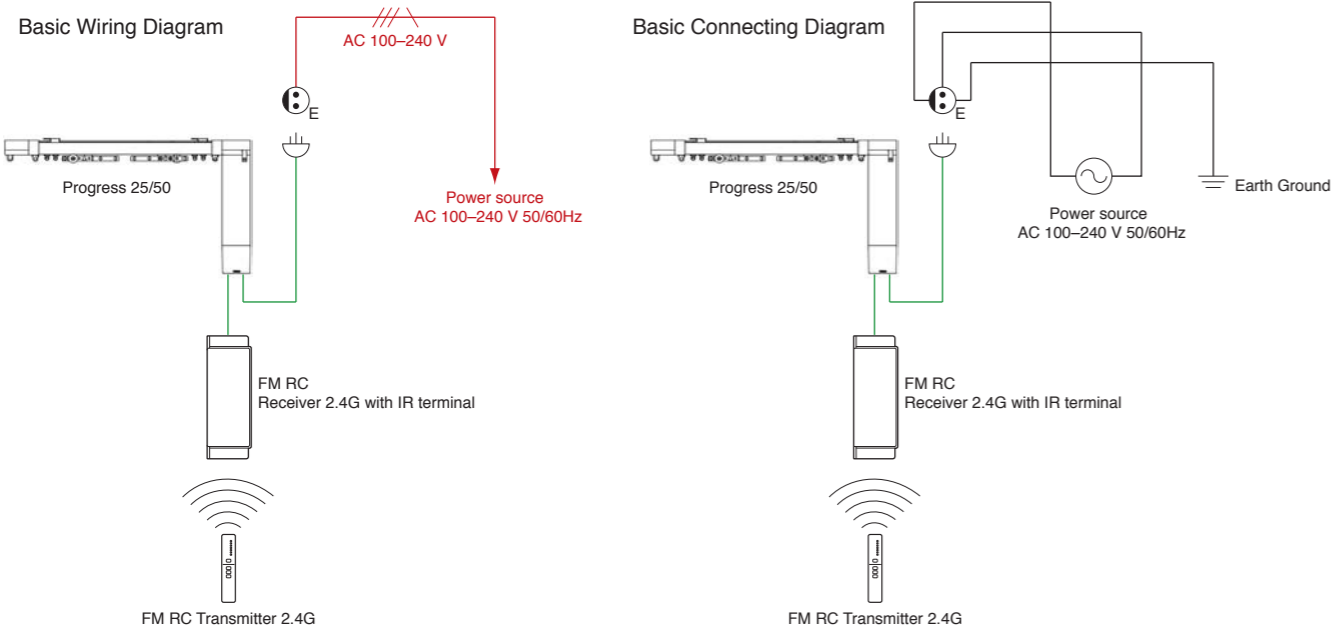

Explanatory notes: — Power supply, — Main body attachment or TOSO standard

Progress 25/50 Rail

White Rail

Size	Product Code
5.00 m (197")	04990014

Progress 25/50 Parts

Product Name	Product Code	Product Name	Product Code	Product Name	Product Code
Progress 50 Motor Set	04990033	Progress 50 Stop	04990022	Master Roller Arm	04990012
		Ceiling Single Bracket M2	01750038	Pilot Roller Plate with Wheel	04990013
Progress 25 Motor Set	30001947	Noiseless Roller	04990006	Drive Belt	04990008
		Pilot Roller	04990007	Belt Joint	04990009
End Side Pulley	04990015	Joint Plate	04990011	Belt Joint Cover	04990010
Motor Side Pulley	04990016			OT Splice	04990020
				Splice Pin	04990021