

■ PRO 36 AUTO | AUTO-FEED DRILLING MACHINE

PRO 36 AUTO - equipped with many advanced systems is an ideal cost saving solution for drilling a large number of holes with diameters up to 36mm and maximum depth up to 51 mm.



■ Superior features of PRO 36 AUTO include:

- Compact, rigid design with ultra-light weight of 13.5 kg
- Perfect combination of spindle speeds and torque reduces cycle times for both TCT and HSS cutters
- Smart control systems for excellent performance and operator's safety
- Dual bars guide system ensures extraordinary stiffness and maintenance free operation
- Top quality magnetic base reduces the minimum work piece thickness to 6mm
- Integrated cutter guard
- Useful large coolant tank



Core drill: max 36 mm



Depth of cut: 51 mm



Stroke: 70 mm



Weight: 13 kg



Minimum work piece
thickness: 6 mm

EXCELLENT PERFORMANCE & PRODUCTIVITY

- Max milling capacity 36 mm and depth of cut 51 mm
- Auto-feed mechanism is activated by pushing the handles in
- Feed control system reduces idle run time and enables smooth start of cutting
- Dynamic control systems adjust the feed speed proportionally to the cutting load which results in shortest possible cutting times for both TCT and HSS cutters
- Auto-feed control stops the machine when the cutter goes through

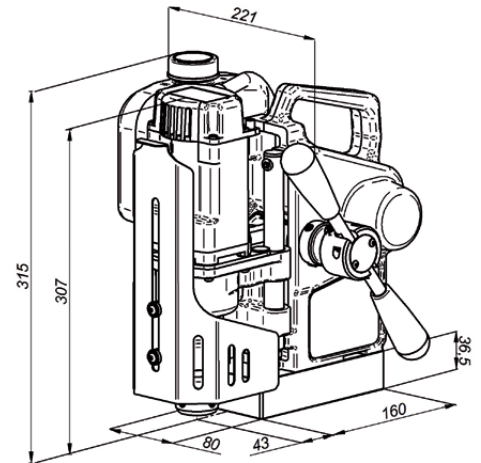

SAFETY

- Overload control stops both cutting and feeding motors immediately
- Magnetic Power Adhesion Control (MPAC) prevents from motor start when the electromagnetic holding force is not sufficient and protects both the machine and the operator from work on improper work piece
- Protection against auto restart after power cut off

USER-FRIENDLY

- Ultra light weight
- Maintenance free dual bars guide system
- Works with standard Weldon shank cutters
- Large coolant tank



PRO 36 AUTO Technical Specification	
Voltage	1~ 110-120 V, 50-60 Hz 1~ 220-240 V, 50-60 Hz
Total power	1000W
Motor power	920W
Cutter holder	19 mm Weldon (0.75")
Max milling capacity	36 mm (1.42")
Max depth of cut	51 mm (2")
Electromagnetic base holding force (surface with the thickness of 25 mm and roughness $R_a = 1.25$)	917 kG (9000 N)
Electromagnetic base dimensions	80 mm × 160 mm × 36.5 mm 3.1" × 6.3" × 1.4"
Slide stroke	70 mm (2.8")
Spindle speed under load	350 rpm
Spindle speed without load	580 rpm
Minimum work piece thickness	6 mm (0.23")
Weight	13.5 kg (30 lbs)
Product Code 220-240 V, 50-60 Hz	WRT-0502-10-20-00-0
Product Code 110-120 V, 50-60 Hz	WRT-0502-10-10-00-0

Standard shipping set:

- PRO 36 AUTO
- Metal box
- Handles
- Cooling system bottle
- Chip guard
- Safety strap
- 4 mm hex wrench
- Operator's Manual



Mitglied im DVS - Deutscher Verband für Schweißen und verwandte Verfahren e. V.



PROMOTECH Sp. z o.o.
ul. Elewatorska 23/1, 15-620 BIAŁYSTOK, POLAND
tel. (+48 85) 678 34 05, fax (+48 85) 662 78 77
marketing@promotech.eu www.promotech.eu

Your local dealer:



AMCOWELD (M) SDN. BHD.
REG NO: 200201028896 (596559-D)
NO: 35-37, JALAN MUTIARA EMAS 6/5, TAMAN MOUNT AUSTIN,
81100 JOHOR BAHRU, JOHOR
TEL : 07-355 6877 (Hunting Line) FAX : 07-355 7177
Email : sales@amcowlend.com.my