

PRO 51 | UNIVERSAL DRILLING MACHINE

PRO 51 is a new generation magnetic drilling machine with Morse Taper No. 2

Superior features of PRO 51 include:

- compact design
- gear box and slide system made as one piece
- excellent ratio weight / power
- maintenance friendly design
- purpose designed motor with heavy duty gear box
- maintenance friendly rail guide system

Unique semi-automatic gib adjustment system (patent pending) enables simple, fast and always correct fine tuning without any expert knowledge or experience. Replaceable spline at the end of armature shaft eliminates laborious and expensive armature maintenance. Compact design allows the operator to drill very close to side wall and corners.

Semi-automatic
gib adjustment

Service friendly

Integrated Gearbox
Housing with Slide









2-Speed Gearbox

Magnetic Field
Shape Control
(MFSC)

Magnetic Power
Adhesion Control
(MPAC)



PRO 51 is equipped with the latest generation of electromagnetic base with magnetic field shape control system (MFSC) and magnetic power adhesion control module (MPAC), which detects adhesive force of electromagnetic base and protects both the machine and the operator from work on too thin workpieces.

							
Core drill max 51 mm	Twist drill max 23 mm	Spindle MT2	Depth of cut 51 mm	Stroke 153 mm	Speed 200, 400 rpm	Motor Power 1260 W	Weight 16,5 kg

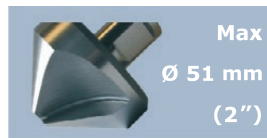
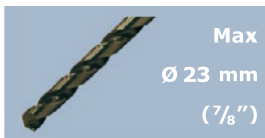

PRO 51 - TECHNICAL SPECIFICATION

Motor Speed (under load)	200, 400 rpm
Motor Power	1260 W
Weight	16,5 kg (35 lbs 9 oz)
Max milling capacity	Ø 51 mm (2")
Max drilling capacity	Ø 23 mm (7/8")
Max countersinking	Ø 51 mm (2")
Stroke	153 mm (6")
Max depth of cut	51 mm (2")
Voltage	1~ 110-120 V, 50-60 Hz 1~ 220-240 V, 50-60 Hz
Power consumption	1300 W
Semi-automatic gib adjustment	yes
MPAC	yes
MFSC	yes
Magnetic clamping force	1224 kG (12000 N) /25 mm, Ra=1,25/
Magnet Base Dimensions	90 x 180 x 48 mm 3-9/16 x 7-1/16 x 1-7/8 (")
Min. Workpiece Thickness	8 mm (5/16")
Spindle	MT2
Tool holder	19 mm (3/4") Weldon
Product Code 220-240 V, 50-60 Hz	WRT-0399-10-20-00-0
Product Code 110-120 V, 50-60 Hz	WRT-0399-10-10-00-0

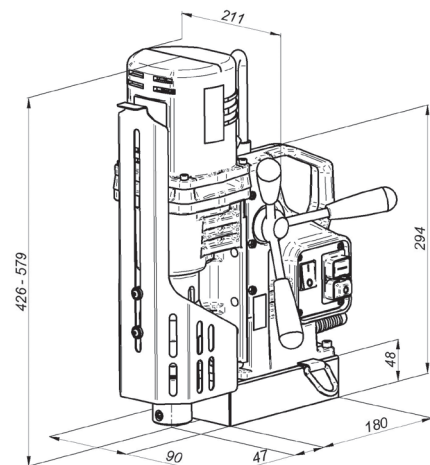

Standard shipping set:

- Magnetic Base Drilling Machine
- Metal Box
- MT2 Arbor with 19mm Weldon Bore - with cooling ring
- Swarf Shield/Cutter Guide
- Coolant Bottle Assembly
- Safety Chain with Snap Hook
- Set of Tools with Wedge
- Operator's Manual (English)
- Standard shipping weight - 26,1 kg (56 lbs 5 oz)

Selected additional accessories:

- UCW-0285-03-00-00-0 Quick Change AMTE2-C19/2-2 Continuous Cooling Arbor with Ring
- PDS-0110-03-00-01-0 DMP0251 Pipe Attachment
- PDS-0111-03-00-01-0 DMP0501 Pipe Attachment
- KNC-0399-09-00-00-0 Cooling attachment for twist drilling
- PDS-0587-00-00-00-0 Vacuum pad
- ZSP-0587-11-00-00-0 Compressed air ejector



Vacuum pad



Compressed air ejector

All information is subject to change without notice. 1908



PROMOTECH Sp. z o.o.
ul. Elewatorska 23/1, 15-620 BIAŁYSTOK, POLAND
tel. (+48 85) 678 34 05, fax (+48 85) 662 78 77
marketing@promotech.eu www.promotech.eu

Your local dealer:



AMCOWELD (M) SDN. BHD.
REG NO: 200201028896 (596559-D)
NO: 35-37, JALAN MUTIARA EMAS 6/5, TAMAN MOUNT AUSTIN,
81100 JOHOR BAHRU, JOHOR
TEL : 07-355 6877 (Hunting Line) FAX : 07-355 7177
Email : sales@amcowed.com.my