

## ■ ABM-14 | PLATE AND PIPE BEVELLER

ABM-14 is a beveling machine designed to mill plates and pipes made of carbon steel, alloy steel, stainless steel or aluminum alloys.

In just one single run the machine can bevel up to 2.6 m/min. (8.5 ft/min.) to a width of 12 mm (1/2") in workpieces with tensile strength of  $R_m \leq 392$  MPa (57,000 psi).

Maximum bevel width is 14 mm (9/16"). Depending on materials two or more runs are needed.

Bevel angles incl. 30° (standard) and with optional angle variation devices also 22.5°, 25°, 35°, 37.5° or 45°.

The machine can bevel plates from the top and bottom.

In the case of the milling tool getting stuck in the material and beveling cannot be continued the direction of rotation of the tool can be reversed to release the machine from the workpiece.

There is no need to wear acoustic protection equipment because the noise produced by the machine does not exceed 70 dB.

### ■ Features & benefits

- fast and efficient
- bevels both small and large pieces to cover most of the common applications for its type
- auto feed on large plates with optional trolley
- beveling of lower edge in inverted position
- standard shearing cutter for machining stainless/alloyed steel
- 2 optional shearing cutters dedicated to carbon steel and to aluminum
- reversible spindle against stuck milling tool
- versatile and transportable on its own trolley
- low noise

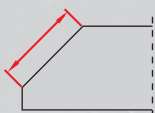

Bevel width  
up to 14 mm  
(9/16")



Bevel angles 30°,  
(option): 22.5°, 25°,  
35°, 37.5°, 45°



Min plate thickness 6 mm  
Max plate thickness  
40 mm (1-9/16")

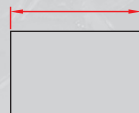

Min plate width  
55 mm  
(2-3/16")



Top  
beveling



Bottom  
beveling



Pipe OD beveling  
Min. ID  
100 mm (4")

### ABM-14 TECHNICAL SPECIFICATION

Voltage	3~ 400 V + PE, 50-60 Hz
Power	2200 W
Spindle speed	9 rpm (for 50 Hz); 11 rpm (for 60 Hz)
Bevel angle range ( $\beta$ - depending on angle device in use)	30° 22.5°, 25°, 35°, 37.5°, 45° (options)
Bevel width (b)	up to 14 mm (9/16")
Maximum bevel in one single run	12 mm (in 40 Kg/ 392 MPa carbon steel)
Minimum plate thickness	6 mm (1/4")
Maximum plate thickness	40 mm (1-9/16")
Minimum plate width	55 mm (2-3/16")
Bevel length per minute	2.6 m (8.5 ft) for 50 Hz; 3.1 m (10.2 ft) for 60 Hz
Minimum pipe ID	100 mm (4")
Weight	65 kg (144 lbs)
Product Code:	UKS-0639-10-40-00-0

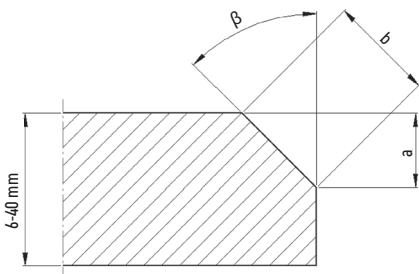

### SINGLE RUN BEVELLING - CARBON STEEL

Rm	≤ 392 MPa (57,000 psi)		392-490 MPa (57,000-71,000 psi)		490-588 MPa (71,000-85,000 psi)	
	b [mm]	a [mm]	b [mm]	a [mm]	b [mm]	a [mm]
22.5°	12	11	10	9	8	7.5
30°	12	10	10	8.5	8	7
35°	12	9.5	10	8	8	6.5
37.5°	12	9	10	7.5	8	6
45°	12	8.5	10	7	8	5.5

### SINGLE RUN BEVELLING - STAINLESS / ALLOY STEEL

Rm	≤ 490 MPa (71,000 psi)		490-588 MPa (71,000-85,000 psi)		588-686 MPa (85,000-100,000 psi)	
	b [mm]	a [mm]	b [mm]	a [mm]	b [mm]	a [mm]
22.5°	6	5.5	5	4.5	4.2	3.8
30°	6	5	5	4.3	4.2	3.6
35°	6	5	5	4	4.2	3.5
37.5°	6	4.5	5	4	4.2	3.3
45°	6	4	5	3.5	4.2	3

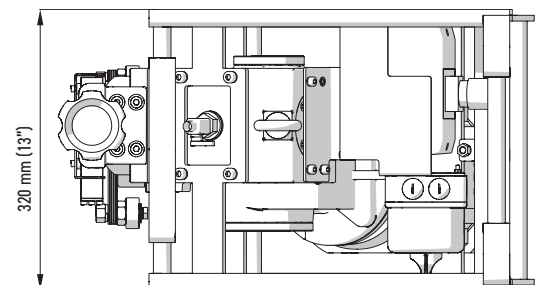
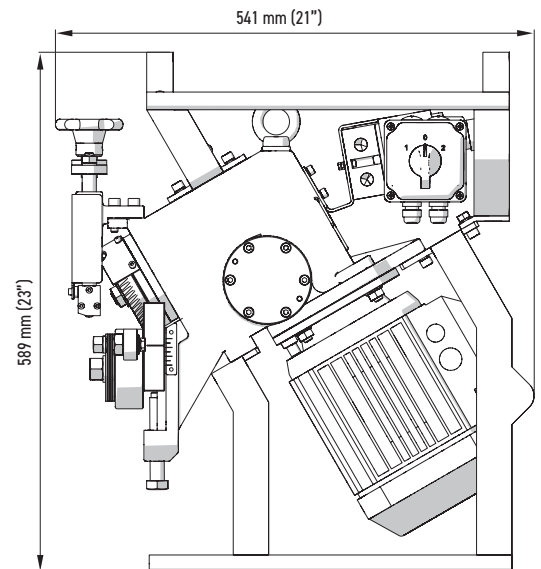

**Standard set includes:**

- ABM-14 beveller
- milling cutter for stainless steel
- cutter extraction tool
- tube beveling shaft
- tube beveling washer
- flat wrenches: 12-13 mm, 18-19 mm, 24-26 mm
- hex wrenches: 5 mm and 6 mm
- operator's Manual

**Optional and spare accessories:**



- FRZ-000586 Milling cutter for carbon steel
- FRZ-000588 Milling cutter for stainless steel
- FRZ-000587 Milling cutter for aluminum



- TRZ-000017 Tube beveling shaft
- PDK-000240 Tube beveling washer



- SCG-000002 Milling cutter extraction tool



- PRW-000100 Angle Variation Device 22.5°
- PRW-000101 Angle Variation Device 25°
- PRW-000105 Angle Variation Device 30°
- PRW-000102 Angle Variation Device 35°
- PRW-000103 Angle Variation Device 37.5°
- PRW-000104 Angle Variation Device 45°



- WOZ-000009 Adjustable trolley



**Multitude of applications:**



Top plate beveling



Bottom plate beveling



Oval workpiece and pipe beveling



Beveling at 30°



Beveling at 45°



Maximum bevel width up to 14 mm



ABM-14 runs along a plate automatically

**Top plate beveling with trolley**

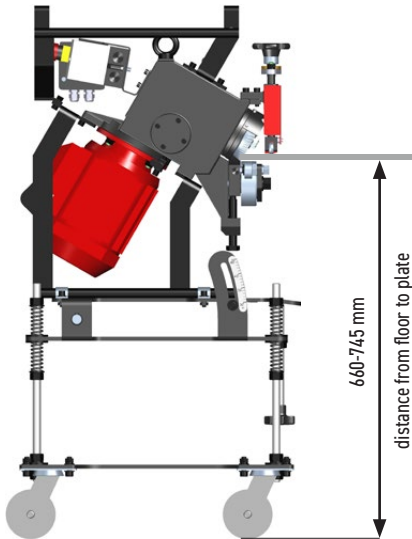

Configuration 1

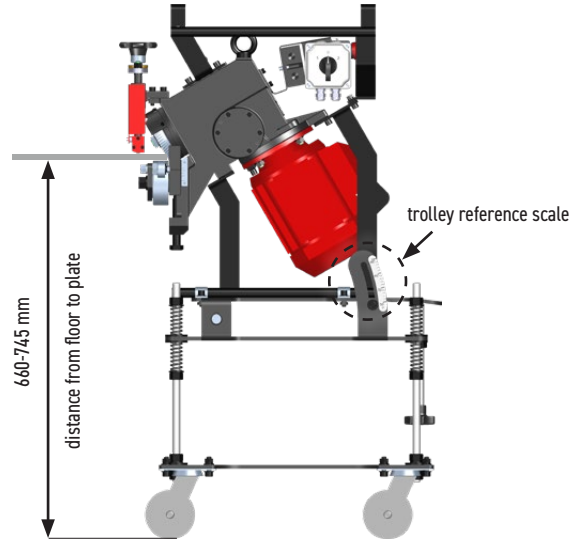

Configuration 2

**Top beveling at 22.5 degrees**

Configuration 1

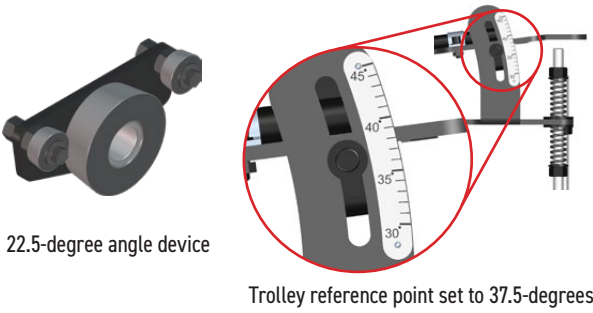

22.5-degree angle device

Trolley reference point set to 37.5-degrees

**Top beveling at 35 degrees**

Configuration 2

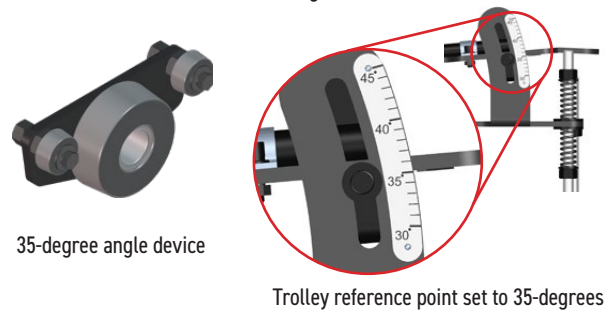

35-degree angle device

Trolley reference point set to 35-degrees

**Top beveling at 25 degrees**

Configuration 1

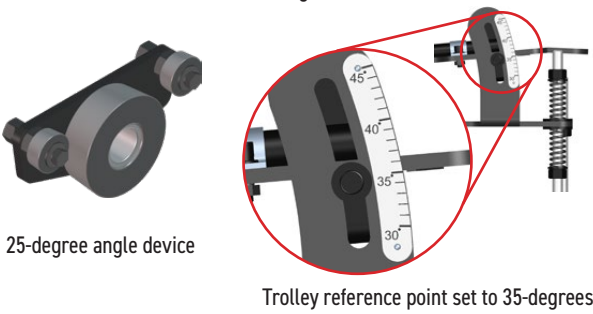

25-degree angle device

Trolley reference point set to 35-degrees

**Top beveling at 37.5 degrees**

Configuration 2

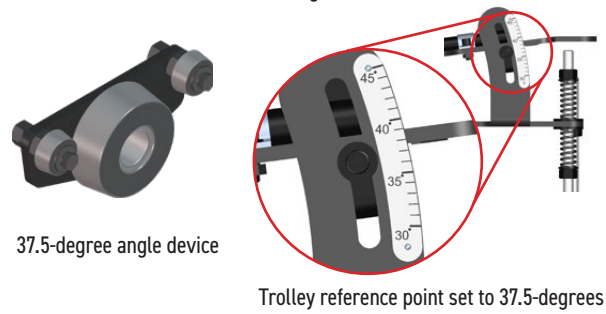

37.5-degree angle device

Trolley reference point set to 37.5-degrees

**Top beveling at 30 degrees**

Configuration 1 or 2

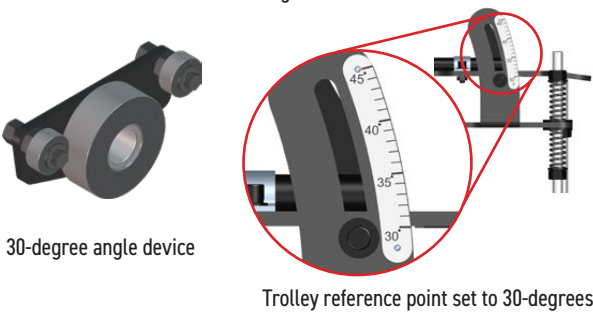

30-degree angle device

Trolley reference point set to 30-degrees

**Top beveling at 45 degrees**

Configuration 2

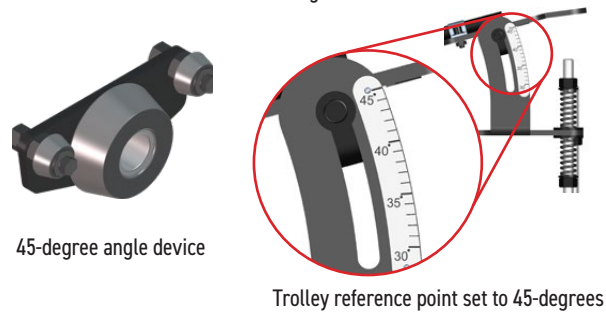

45-degree angle device

Trolley reference point set to 45-degrees

**Bottom plate beveling with trolley**

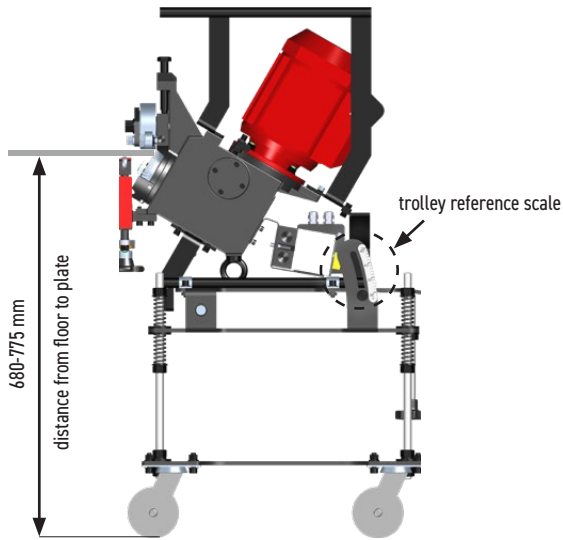

Configuration 3

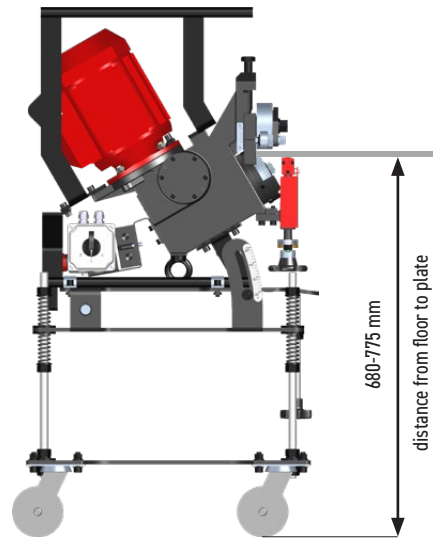

Configuration 4

**Bottom beveling at 22.5 degrees**

Configuration 3

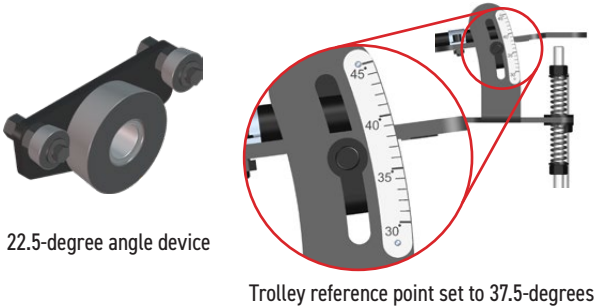

22.5-degree angle device

Trolley reference point set to 37.5-degrees

**Bottom beveling at 35 degrees**

Configuration 4

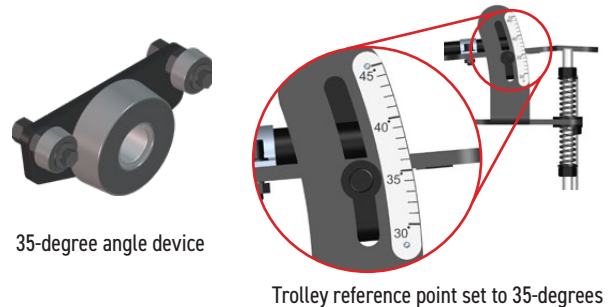

35-degree angle device

Trolley reference point set to 35-degrees

**Bottom beveling at 25 degrees**

Configuration 3

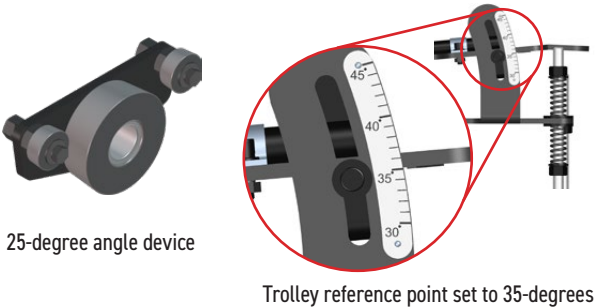

25-degree angle device

Trolley reference point set to 35-degrees

**Bottom beveling at 37.5 degrees**

Configuration 4

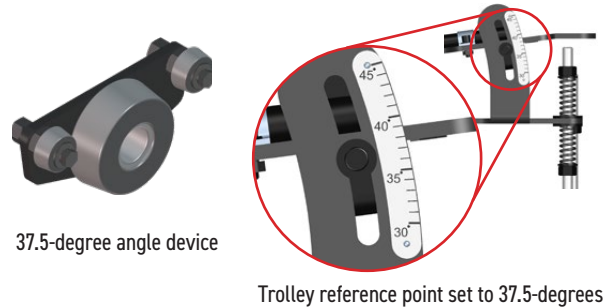

37.5-degree angle device

Trolley reference point set to 37.5-degrees

**Bottom beveling at 30 degrees**

Configuration 3 or 4

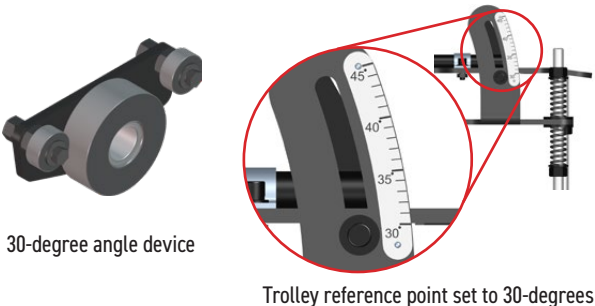

30-degree angle device

Trolley reference point set to 30-degrees

**Bottom beveling at 45 degrees**

Configuration 4

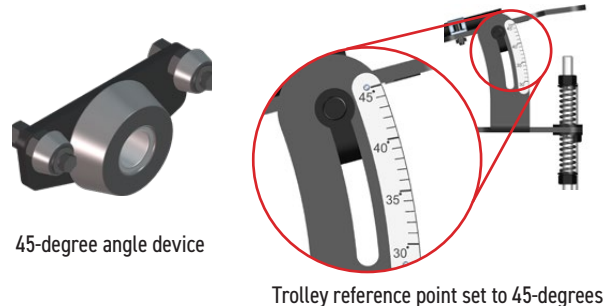

45-degree angle device

Trolley reference point set to 45-degrees

All information is subject to change without notice. 1910



PROMOTECH Sp. z o.o.  
ul. Elewatorska 23/1, 15-620 BIAŁYSTOK, POLAND  
tel. (+48 85) 678 34 05, fax (+48 85) 662 78 77  
marketing@promotech.eu www.promotech.eu

Your local dealer:



**AMCOWELD (M) SDN. BHD.**  
REG NO: 200201028896 (696559-D)  
NO: 35-37, JALAN MUTIARA EMAS 6/5, TAMAN MOUNT AUSTIN,  
81100 JOHOR BAHRU, JOHOR  
TEL : 07-355 6877 (Hunting Line) FAX : 07-355 7177  
Email : sales@amcoweld.com.my