

PRO 45/2 ATEX | PNEUMATIC DRILLING MACHINE

PRO 45/2 ATEX is a small portable pneumatic drilling machine which allows cutting holes up to 45 mm (1-3/4") diameter.

Combination of pneumatic drive and permanent magnetic base eliminate the need of electric power supply thus making this machine an ideal solution in many hazardous environments such as oil drilling platforms, petrochemical plants, oil refineries, shipbuilding and petrochemical industry, where electric appliances are prohibited for safety reasons.

Features & benefits:

- intended for use in potentially explosive atmospheres
- no need for electric power
- strong permanent magnet base
- great safety features
- protection against motor start-up when magnetic base is not activated
- 2-gear box

PRO 45/2 ATEX
conforms to
ATEX II 2 G/D c IIC T6/T4
Standard for equipment used
in hazardous environments

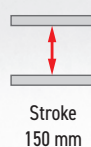
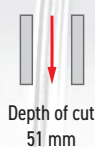

PRO 45/2 ATEX TECHNICAL SPECIFICATIONS

Motor speed (under load)	190 rpm (gear I) 290 rpm (gear II)
Motor power	800 W
Weight	26.5 kg (58.5 lbs)
Max milling capacity	45 mm (1-3/4")
Max drilling capacity	20 mm (13/16")
Stroke	150 mm (6")
Max depth of cut	51 mm (2")
Tool holder	19 mm (3/4") Weldon
Air consumption	1400 l/min (50 CFM)
Pressure	6 bar (87 psi)
Air connection	CEJN 410 DN 10.4 R 3/8" BSPT fitting for quick-coupling
Spindle	MT2
Minimum workpiece thickness	10 mm (3/8")
Required ambient temperature	0-40°C (32-104°F)
Magnetic base holding force	765 kG (7 500 N)
Magnetic base dimensions	80 mm x 80 mm x 143 mm (3.15" x 3.15" x 5.63")
Overall dimensions LxWxH	424 mm x 268 mm x 703 mm 16.7" x 10.5" x 27.7"
Product Code	WRT-0632-10-00-00-0

Dimensions

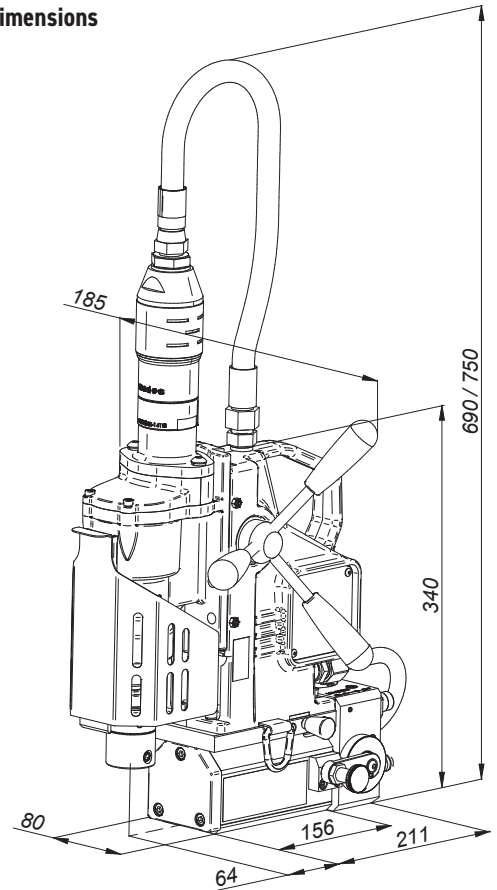

Standard shipping set:

- pneumatic drilling machine
- metal box
- feed handles
- MT2 arbor
- safety chain
- cooling system
- protective spring for cooling hose
- set of tools
- operator's manual



All information is subject to change without notice. 1908



PROMOTECH Sp. z o.o.
ul. Elewatorska 23/1, 15-620 BIAŁYSTOK, POLAND
tel. (+48 85) 678 34 05, fax (+48 85) 662 78 77
marketing@promotech.eu www.promotech.eu

Your local dealer:



AMCOWELD (M) SDN. BHD.
REG NO: 200201028896 (596559-D)
NO: 35-37, JALAN MUTIARA EMAS 6/5, TAMAN MOUNT AUSTIN,
81100 JOHOR BAHRU, JOHOR
TEL : 07-355 6877 (Hunting Line) FAX : 07-355 7177
Email : sales@amcowedd.com.my