

DAIKIN

涡旋压缩机

SCROLL COMPRESSOR



西安大金庆安压缩机有限公司

西安大金庆安压缩机有限公司生产定频与变频式涡旋压缩机，在技术上与日本大金保持同步，是日本大金工业株式会社正在生产的最先进的机种，充分体现了大金近80年间专业制冷技术的卓越成就，超前的技术，独特的创造，近乎完美的专业化设计，细致入微的制作，无处不体现出大金在制冷技术方面的尖端风范。

XI'AN DAIKIN QING'AN COMPRESSOR CO., LTD. manufactures NON-INVERTER and INVERTER scroll compressors with DAIKIN JAPAN at the same time. DAIKIN which has 80 years of experiences of manufacturing central air conditioners takes a leading position in HVAC market. Using DAIKIN's refrigerant technology, we have contrived advanced technology, originality, perfect design and precious manufacturing in XI'AN.

压缩机系列频谱

所有压缩机均采用大金特有的技术开发和生产。从1946年开始生产往复式压缩机以来，大金以独有的技术，开发生产了各种类型和各种能力范围的压缩机。

All compressors are developed and manufactured with DAIKIN's unique technologies. DAIKIN started manufacturing reciprocal compressors in 1946. Since then, DAIKIN has been developing and manufacturing a wide variety of compressors for a wide power range with DAIKIN's unique technologies employed.

大金压缩机的阵容

制冷剂 REF.	系列 SERIES	制冷量 CAPACITY											
		Kw	4.6	8.5	9.2	11.7	15.0	15.6	18.5	21.5	34.0	43.0	68.0
		KBTU/H 15.7 29.1 31.4 40.0 51.2 53.2 63.1 73.4 116.1 146.8 293.6											
R22	B	B型压缩机											
	G	G型压缩机											
	D					D型压缩机		2台并联					
	INV	INV型压缩机		2台并联									
R407C	G	G型压缩机											
	D					D型压缩机							
R410A	G	G型压缩机											

大金涡旋式压缩机的历史

- 1984年：引进涡旋压缩机的技术
- 1988年：开始批量生产使用A系列涡旋式压缩机的空调机
(扩大到变频器，容量可控制压缩机，多联式压缩机等)
- 1991年：采用大金独有技术，开发·生产小型，高效，低振动的B系列(~6HP)涡旋式压缩机
(扩大到变频压缩机，多联压缩机，低温，超低温用氨制冷压缩机等)
- 1997年：开发·生产R407C以及R22/407C通用的D系列压缩机
- 1998年：开发·生产R22/407C通用的F系列压缩机(~6HP)
行业内第一个将磁阻式直流电机用于涡旋式压缩机
- 2004年：开发全球统一规格的R410A/R407C/R22的G系列压缩机(~6HP)并在泰国和中国生产
开发·生产R410A的D系列压缩机(~12HP)
- 2007年：开发·生产节能型G系列非对称涡旋盘压缩机

- 1984: Scroll compressor technology was introduced.
- 1988: Mass production of products incorporating A-type scroll compressors started.
- 1991: Compact, high-performance, and low-vibration B-type scroll compressors (up to 6 HP) was developed and manufactured with DAIKIN's unique technologies.
- 1997: D-type compressor using R407C or both R22 and R407C was developed and manufactured.
- 1998: F-type compressor (up to 6 HP) using both R22 and R407C was developed and manufactured.
The industry's first reluctance DC motor was mounted in a scroll compressor
- 2004: Global version G-type compressor (up to 6 HP) using R410A, R407C or R22 was developed and its production was started in Thailand and China.
D-type compressor (up to 12 HP) using R410A was developed and its production started.
- 2007: Energy-saving G-type collaboration scroll compressor was developed and manufactured.

涡旋式压缩机

Scroll compressors

通过采用先进的涡旋技术，始终保持行业第一的高效能。通过流畅地运转，实现了“强大动力”和“静音运转”，并进一步提高了能效的新型涡旋压缩机。

压缩机构造

独有的新型涡卷形状和高低压腔结构提高了能效

无用的冷媒通道消除，减少冷媒二次膨胀，能效大幅提高。

冷媒通路
(导致热量损失等)



以前的涡旋压缩机

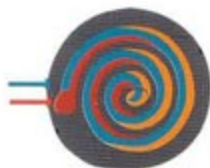

新型涡旋压缩机



低压腔
高压腔

冷媒在进入高压腔（电机部分）之前直接在低压腔（涡旋盘）进行了压缩，抑制了冷媒的二次膨胀，提高了能效。

图A

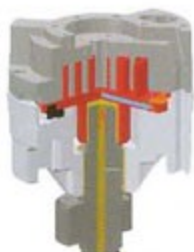

图B（涡旋盘图）

高压油注入时的反作用力降低了动盘运动时产生的摩擦损失，提高了效率。

多联式涡旋压缩机

Manifold type scroll compressors

大金压缩机独有的多联技术，（油面控制，冷媒控制技术）成就了高可靠性的楼宇用多联空调机。



多台压缩机高效运转

■油面控制技术

低压腔：

利用压缩机内部低压部分的压力差和安装均油管稳定油面。

高低压腔：

通过控制压缩机的上油量来稳定油面（油面上升时上油增多，降低时减少）。

■冷媒控制技术

大量的液态冷媒回到小容量的压缩机时，容易引起压缩机涡旋盘破碎，轴套烧损的故障。

避免轴套烧损的技术：高强度轴套

避免液压缩的技术：泄压阀轴向柔性构造

B 型系列高效涡旋压缩机

行业最高水平的效率

采用高精度加工，独特组装技术以及油膜密封技术实现了高效率。

行业最好水平的静音化

采用动静盘非接触构造，实现了高水平的静音及低振动。

高可靠性、高寿命

由于涡旋压缩机运动部件少，反复冲击少，滑动速度低，因此可靠性高，寿命长。

运行电压范围宽

适合于中国市场的电压设计，保证压缩机在 $\pm 10\%$ 范围内正常工作。

物超所值

简化空调系统设计，减少设计负荷，降低综合成本，提高市场竞争力。



High efficiency

We provide high efficiency compressors by greater accurate machining, particular assembling and oil seal technology.

Low sound levels

Using un-contact scroll, we have accomplished low sound power levels and low vibration.

High reliability, long operating life

Our scroll compressors have fewer moving parts, low reiteration impulsion and low sliding velocity.

Wide operating voltage range

Our compressors are guaranteed within voltage rang ($\pm 10\%$) for China market.

Special value

Due to simplifying system design and saving cost, it would enhance your product competitive in market to use DAIKIN compressors.

G 型系列高效涡旋压缩机



高效率

采取高低压腔
采取轴向柔性结构
采取非对称涡旋盘结构

高效率的优点

吸入气体的最大热绝缘
由柔性结构的油膜作用而产生的密封技术
非对称涡旋盘结构

高可靠性

采取高低压腔结构
采取轴向柔性结构
采取干式轴承

高可靠性的优点

很强的抗液击柔性结构
对低噪音、环境温度的适用性很强
采用干式轴承

Advantage in high efficiency

Maximum thermal insulation of suction gas
Maximum sealing by compliance mechanism and oil film sealing effect
Asymmetric scroll

Advantage in high reliability

Compliance mechanism to withstand liquid attack
Low noise and high adaptability to the ambient temperature
Dry type journal bearing

D 型系列高效能涡旋压缩机

3 factors in high efficiency

Proper distribution of suction gas
Asymmetric scroll
Low distortion of fixed scroll

3 factors in high reliability

Proper cooling of motor
Ball bearing
Dry type journal bearing

Application

D model compressors are installed in DAIKIN Air Packaged Water Chillers. They are ideally used in combination with the Fan Coil Units and/or the Air Handling Units for air conditioning of offices, hotels, restaurants and hospitals.

高效率三大要素

采用吸气最佳分配结构
采用非对称涡旋盘
采用低变形量的固定涡旋盘

高可靠性的三大要素

采用电机最佳冷却结构
采用滚动轴承
采用干式轴承

应用

D型压缩机应用于小箱体水冷机组。它和风机盘管系统装置或空气处理设备组合一起使用。应用于办公室、宾馆、餐厅、医院的空调上以及供给工业冷水的装置。



变频系列高效能涡旋压缩机

变频式性能特点:

- 全球首次采用400V电机
- 采用非接触涡旋盘和固定偏心量
- 采用干式轴承
- 采用容积式油泵供油
- 采用了小型管体、三脚底座
- 适用于商用电源
- 低噪音、低振动
- 高可靠性
- 体积小、重量轻
- 低油量循环

- 400V motor
- Uncontact scroll & fixed eccentric
- Amount dry bearing
- Volumetric oil pump
- Compact mainframe & 3 mounting grommets
- Commercial power source
- Low noise & low vibration
- High reliability
- Compact & light weight
- Low oil volume circulation



B 型定频压缩机型谱 制冷剂 R22

标称 HP	电源	型号	性能						排量 cm ³ /r	管路连结	
			测定电源	制冷量		输入功率 KW	电流A	COP (w/w)		吸气管mm	排气管mm
				KW	BTU/H						
3	220V/50Hz 单相	JT90BCBV1L	220V/50Hz	8.54	29100	2.87	13.1	2.98	2.98	φ22.2	φ9.5
3		JT95BCBV1L	220V/50Hz	9.03	30800	2.98	13.7	3.03	3.03	φ22.2	φ9.5
3		JT100BCBV1L	220V/50Hz	9.51	32400	3.14	14.5	3.03	3.03	φ22.2	φ9.5
3		JT90BHBV1L	220V/50Hz	8.55	29200	2.67	12.4	3.2	3.2	φ22.2	φ9.5
3		JT95BHBV1L	220V/50Hz	9.2	31400	2.88	13.5	3.2	3.2	φ22.2	φ9.5
3	380V/50Hz 三相	JT90BCBY1L	380V/50Hz	8.54	29100	2.75	4.8	3.11	48.6	φ19.1	φ9.5
3		JT95BCBY1L	380V/50Hz	9.03	30800	2.87	4.9	3.15	51.2	φ19.1	φ9.5
3		JT90BHBV1L	380V/50Hz	8.55	29200	2.6	4.6	3.29	48.2	φ19.1	φ9.5
3		JT95BHBV1L	380V/50Hz	9.2	31400	2.8	4.8	3.29	51.8	φ19.1	φ9.5
4.5		JT140BCBY1L	380V/50Hz	13.2	45000	4.11	7.6	3.22	74.1	φ19.1	φ9.5
5	JT150BCBY1L	380V/50Hz	14	47800	4.42	8.1	3.17	78.1	φ19.1	φ9.5	
4	380V 50/60Hz三相	JT125BC-Y1L	380V/50Hz	11.9	40600	3.8	7.0	3.13	67	φ19.1	φ12.7
			380V/60Hz	14.2	48500	4.53	7.4	3.13			
JT125BCBY1L		380V/50Hz	11.9	40600	3.8	7.0	3.13	67	φ19.1	φ12.7	
		380V/60Hz	14.2	48500	4.53	7.4	3.13				
5		JT160BC-Y1L	380V/50Hz	15	51200	4.66	8.6	3.22	83.1	φ19.1	φ12.7
			380V/60Hz	17.9	61100	5.54	9.2	3.23			
JT160BCBY1L	380V/50Hz	15	51200	4.66	8.6	3.22	83.1	φ19.1	φ12.7		
	380V/60Hz	17.9	61100	5.54	9.2	3.23					

压缩机测试条件					
	蒸发温度	冷凝温度	过冷度	过热度	环境温度
压缩机	7.2℃	54.4℃	8.3℃	27.8℃	35℃

B 型定频压缩机标准尺寸 制冷剂 R22

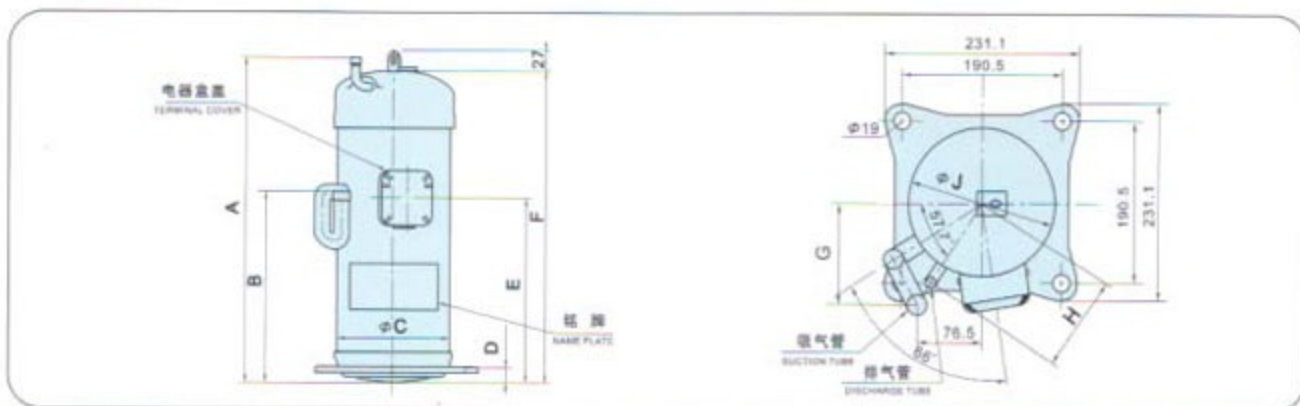

型号	A	B	C	D	E	F	G	H	J
JT90(95)BC(H)BY1L	448.8	260.0	156.4	20.9	262.5	445.0	110.5	102.2	164.2
JT90(95)BC(H)BV1L	462.8	271.0	156.4	20.9	276.5	459.8	110.5	102.2	164.2
JT125BCBY1L	462.3	273.0	166.1	20.8	273.0	445.8	120.1	111.7	174.0
JT125BCBY1L	476.3	283.0	166.1	20.8	275.5	459.8	120.1	111.7	174.0

B型变频/并联压缩机型谱 制冷剂 R22

标称 HP	电源	型号	性能						排量 cm ³ /r	管路连结		备注
			测定电源	制冷量		输入功率 KW	电流A	COP (w/w)		吸气管 mm	排气管 mm	
				KW	BTU/H							
5	变频电源	JT100BHV	190V/90Hz	15.2	51800	5.84	20.9	2.6	53.9	φ19.1	φ9.5	A
5	变频电源	JT100BHVYE	383V/90Hz	15.2	51800	5.84	10.6	2.6	53.9	φ19.1	φ9.5	A
5	变频电源	JT100BAVYE	383V/90Hz	15.2	51800	5.84	10.6	2.6	53.9	φ22.2	φ12.7	A
5	380V/50Hz	JT100BATYE	380V/50Hz	9.34	31800	2.97	5.28	3.14	53.9	φ19.1	φ12.7	B
5	380V/50Hz	JT160BATYE	380V/50Hz	15	51200	4.63	8.06	3.24	83.1	φ19.1	φ12.7	B
5	380V/50Hz	JT160BATY1L	380V/50Hz	15	51200	4.66	8.6	3.22	83.1	φ19.1	φ12.7	B

压缩机测试条件						
	蒸发温度	冷凝温度	过冷度	过热度	环境温度	备注
压缩机	5℃	55℃	5℃	8℃	35℃	A
	7.2℃	54.4℃	8.3℃	27.8℃	35℃	B

B型变频/并联压缩机标准尺寸 制冷剂 R22

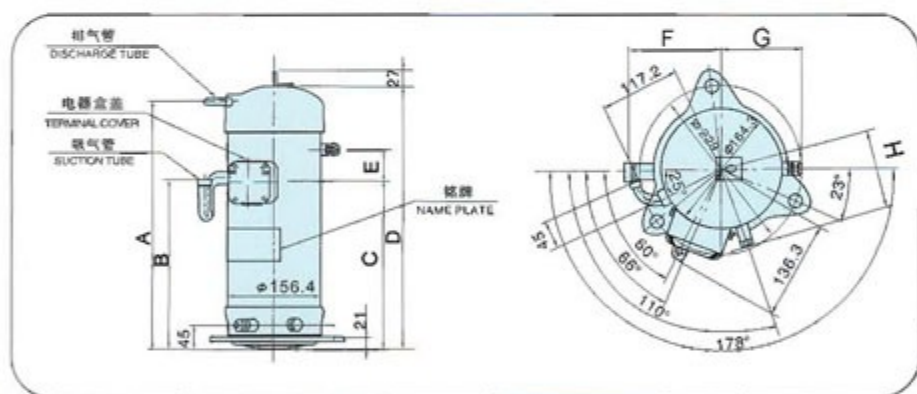

型号	JT100BAV TYE	JT160BAT Y1L(YE)
A	441.6	455.9
B	302	319.2
C	299.5	311.7
D	482	496
E	52.1	65.2
F	140.2	136
G	114.3	119.2
H	108.5	113.4

B型并联压缩机标准尺寸 制冷剂 R22

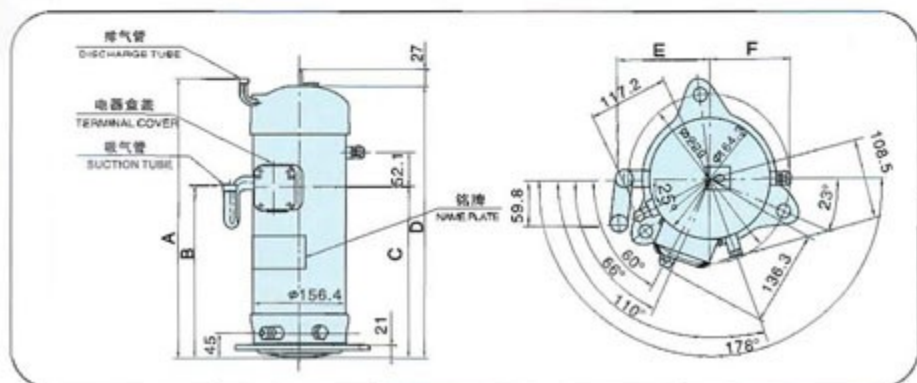

型号	JT100BHV (YE)	JT100BAT YE
A	451.8	483.6
B	263	294
C	265.5	296.5
D	448	479
E	124.4	131.1
F	114.3	114.3

G 型压缩机型谱 制冷剂 R22

标称 HP	电 源	型 号	性 能						排量 cm ³ /r	管路连接		备注
			测定电源	制冷量		输入功率 KW	电流A	cop (w/w)		吸气管mm	排气管mm	
				KW	BTU/H							
3	220V/50Hz 单相	JT90GABV1L	220V/50Hz	8.41	28700	2.56	11.9	3.3	45.8	φ22.1-φ22.25	φ16-φ16.15	A
3		JT95GABV1L	220V/50Hz	9.07	30900	2.75	12.8	3.3	49.4	φ22.1-φ22.25	φ16-φ16.15	A
3		JT100GABV1L	220V/50Hz	9.33	31800	2.83	13.2	3.3	49.8	φ22.1-φ22.25	φ16-φ16.15	A
4		JT125GA-V1	220V/50Hz	11.7	39900	3.55	17.6	3.3	63.2	φ22.35-φ22.5	φ16-φ16.15	A
4	380~415V 三相 50Hz	JT125GABY1	380V/50Hz	11.7	39900	3.44	6	3.4	63.2	φ22.1-φ22.25	φ16-φ16.15	A
		JT125GA-Y1	380V/50Hz	11.7	39900	3.44	6	3.4	63.2	φ22.1-φ22.25	φ16-φ16.15	A
5		JT160GA-Y1	380V/50Hz	14.6	49800	4.3	7.5	3.4	79.2	φ22.1-φ22.25	φ16-φ16.15	A
		JT160GABY1										
5.5		JT170GA-Y1	380V/50Hz	15.6	53200	4.59	8.1	3.4	84	φ22.1-φ22.25	φ16-φ16.15	A
4	220V 三相 50/60 Hz	JT125GABTAL	220V/60Hz	13.9	47400	4.09	12	3.4	63.2	φ22.35-φ22.5	φ16-φ16.15	A
5		JT160GABTAL	220V/60Hz	17.4	59400	5.12	15.2	3.4	79.2	φ22.35-φ22.5	φ16-φ16.15	A
5.5		JT170GABTAL	220V/60Hz	18.6	63500	5.47	16.1	3.4	84	φ22.35-φ22.5	φ16-φ16.15	A
3	380V 三相 50Hz	JT90GABY1L	380V/50Hz	8.41	28700	2.47	4.36	3.4	45.8	φ22.35-φ22.5	φ16-φ16.15	A
3		JT95GABY1L	380V/50Hz	9.07	30900	2.67	4.62	3.4	49.4	φ22.35-φ22.5	φ16-φ16.15	A
4		JT125GABY1L	380V/50Hz	11.7	39900	3.44	6	3.4	63.2	φ22.35-φ22.5	φ16-φ16.15	A
4.5		JT150GABY1L	380V/50Hz	13.7	46700	4.03	7.3	3.4	74.3	φ22.1-φ22.25	φ16-φ16.15	A
5		JT160GABY1L	380V/50Hz	14.6	49800	4.3	7.5	3.4	79.2	φ22.1-φ22.25	φ16-φ16.15	A
5.5		JT170GABY1L	380V/50Hz	15.6	53200	4.59	8.1	3.4	84	φ22.1-φ22.25	φ16-φ16.15	A
5		JT132GHBY1L	380V/50Hz	12.4	42300	3.65	6.1	3.4	67	φ22.1-φ22.25	φ16-φ16.15	A
				11.9	40600	3.14	5.4	3.8	67	φ22.1-φ22.25	φ16-φ16.15	B
5		JT140GHBY1L	380V/50Hz	12.9	44000	3.8	6.59	3.4	70	φ22.1-φ22.25	φ16-φ16.15	A
				12.3	42000	3.29	5.87	3.74	70	φ22.1-φ22.25	φ16-φ16.15	B
5		JT140GHSY1L	380V/50Hz	12.9	44000	3.8	6.33	3.4	70	φ22.1-φ22.25	φ16-φ16.15	A
				12.3	42000	3.29	5.55	3.74	70	φ22.1-φ22.25	φ16-φ16.15	B

压缩机测试条件

	蒸发温度	冷凝温度	过冷度	过热度	环境温度	备注
压缩机	7.2℃	54.4℃	8.3℃	11.1℃	35℃	A
	5℃	48℃	5℃	8℃	35℃	B(参考值)

G型压缩机型谱 制冷剂R407C

标称 HP	电 源	型 号	性 能							管路连结	
			测定电源	制冷量		输入功率 KW	电流A	COP (w/w)	排量 cm ³ /r	吸气管mm	排气管mm
				KW	BTU/H						
3	220V/50Hz 单相	JT90GBBV1L	220V/50Hz	8.49	29000	2.73	12.7	3.11	45.8	φ22.1-φ22.25	φ16-φ16.15
3		JT95GBBV1L	220V/50Hz	9.16	31300	2.95	13.6	3.11	49.4	φ22.1-φ22.25	φ16-φ16.15
4		JT125GBBV1L	220V/50Hz	11.8	40300	3.8	18.7	3.11	63.2	φ22.35-φ22.5	φ16-φ16.15
3	380V/50Hz 三相	JT90GBBY1L	380V/50Hz	8.49	29000	2.65	4.6	3.2	45.8	φ22.1-φ22.25	φ16-φ16.15
3		JT95GBBY1L	380V/50Hz	9.16	31300	2.86	4.9	3.2	49.4	φ22.1-φ22.25	φ16-φ16.15
4		JT125GBBY1L	380V/50Hz	11.8	40300	3.69	6.4	3.2	63.2	φ22.35-φ22.5	φ16-φ16.15
5		JT160GBBY1L	380V/50Hz	14.7	50200	4.6	7.95	3.2	79.2	φ22.1-φ22.25	φ16-φ16.15
5.5		JT170GBBY1L	380V/50Hz	15.7	53600	4.91	8.5	3.2	84	φ22.35-φ22.5	φ16-φ16.15

压缩机测试条件

	蒸发温度	冷凝温度	过冷度	过热度	环境温度
压缩机	7.2°C	54.4°C	8.3°C	11.1°C	35°C

※R407C的冷凝温度和蒸发温度按中间温度法

G型压缩机标准尺寸 制冷剂R22/R407C

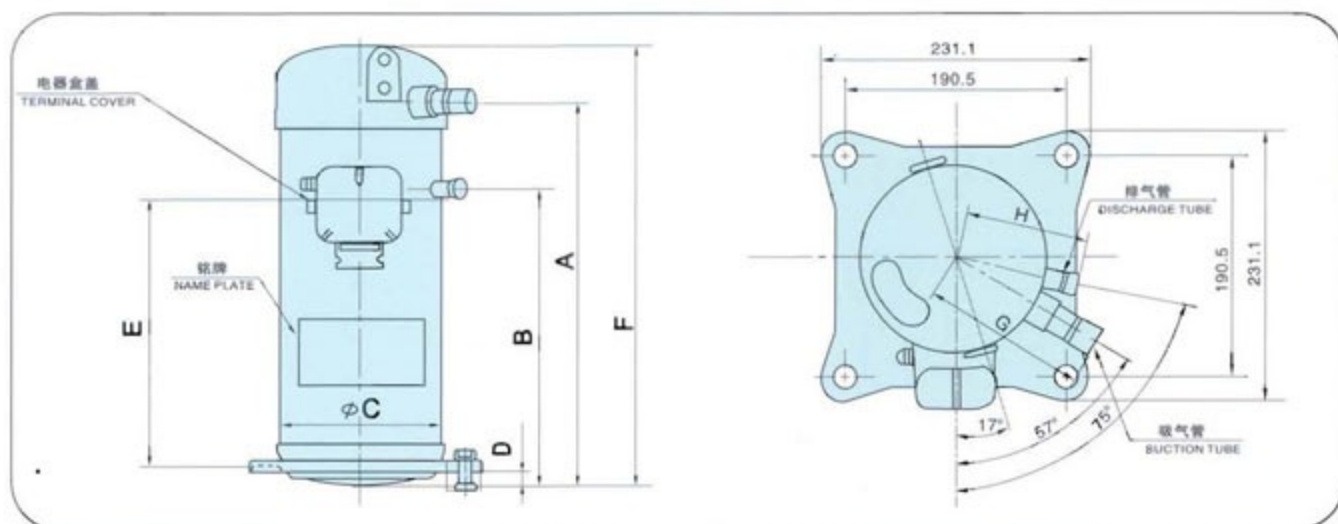

型 号	A	B	C	D	E	F	G	H
JT90、JT95、JT100	342.3	258.3	156.4	20.7	256.1	397.8	132.3	106.7
JT132、JT140	349.8	265.8	165.9	20.6	263.6	412.6	137.3	111.4
JT125~JT170								

G型压缩机型谱 制冷剂R410A

标称 HP	电 源	型 号	性 能						排量 cm ³ /r	管路连结		
			测定电源	制冷量		输入功率 KW	电流A	cop (w/w)		吸气管mm	排气管mm	
				KW	BTU/H							
3	220~230V 单相 50Hz	JT90G-P8V1N	220V/50Hz	8.54	29100	2.95	13.4	2.89	33.1	φ19.17~φ19.32	φ16~φ16.15	
		JT90G-P4V1N										
4	220~240V 单相 50Hz	JT125G-P8V1	230V/50Hz	11.8	40300	4.08	19.9	2.89	46	φ19.17~φ19.32	φ16~φ16.15	
		JT125G-P4V1										
3	380~415V 三相 50Hz	JT71G-P8Y1	380V/50Hz	6.74	22000	2.25	4.00	3.00	26.1	φ19.17~φ19.32	φ16~φ16.15	
3		JT85G-P8Y1	380V/50Hz	8.06	27500	2.69	4.8	3.00	31.3	φ19.17~φ19.32	φ16~φ16.15	
3		JT90G-P8Y1	380V/50Hz	8.54	29100	2.84	4.9	3.00	33.1	φ19.17~φ19.32	φ16~φ16.15	
3		JT90G-P4Y1	400V/50Hz	8.54	29100	2.83	4.7	3.01	33.1	φ19.17~φ19.32	φ16~φ16.15	
3		JT118G-P8Y1	380V/50Hz	11.14	38000	3.71	6.2	3.00	43.4	φ19.17~φ19.32	φ16~φ16.15	
4		JT125G-P8Y1	400V/50Hz	11.8	40300	3.93	6.5	3.00	46	φ19.17~φ19.32	φ16~φ16.15	
		JT125G-P4Y1										
5		JT140G-P8Y1	380V/50Hz	13.06	44500	4.28	7.5	3.05	49.7	φ19.17~φ19.32	φ16~φ16.15	
		JT140G-P4Y1										
5		JT160G-P8Y1	400V/50Hz	14.93	50900	4.88	8.3	3.06	56.8	φ19.17~φ19.32	φ16~φ16.15	
		JT160G-P4Y1										
5.5		JT170G-P8Y1	400V/50Hz	15.91	54300	5.2	8.9	3.06	60.5	φ19.17~φ19.32	φ16~φ16.15	
		JT170G-P4Y1										
3		208~230V 单相 60Hz	JT71G-P8VJ	230V/60Hz	8.13	27700	2.81	14.6	2.89	26.1	φ19.17~φ19.32	φ16~φ16.15
3	JT85G-P8VJ		230V/60Hz	9.73	33200	3.37	14.6	2.89	31.3	φ19.17~φ19.32	φ16~φ16.15	
3	JT90G-P8VJ		230V/60Hz	10.3	35100	3.56	15.4	2.89	33.1	φ19.17~φ19.32	φ16~φ16.15	
3	JT100G-P8VJ		230V/60Hz	10.97	37400	3.8	16.6	2.89	33.1	φ19.17~φ19.32	φ16~φ16.15	
3	JT112G-P8VJ		230V/60Hz	12.6	43000	4.29	18.9	2.94	41.2	φ19.17~φ19.32	φ16~φ16.15	
3	JT118G-P8VJ		230V/60Hz	13.31	45400	4.53	19.9	2.94	43.4	φ19.17~φ19.32	φ16~φ16.15	
4	JT125G-P8VJ		230V/60Hz	14.1	48100	4.8	21.1	2.94	46.0	φ19.17~φ19.32	φ16~φ16.15	
5	JT140G-P8VJ		230V/60Hz	15.47	53100	5.27	23.5	2.94	49.7	φ19.17~φ19.32	φ16~φ16.15	
3	250~280V 单相 60Hz		JT71G-P8VD	265V/60Hz	8.13	27700	2.81	10.6	2.89	26.1	φ19.17~φ19.32	φ16~φ16.15
3			JT85G-P8VD	265V/60Hz	9.73	33200	3.37	12.7	2.89	31.3	φ19.17~φ19.32	φ16~φ16.15
3	208~230V 三相 60Hz	JT71G-P8TJ	230V/60Hz	8.13	27700	2.82	8.33	2.88	26.1	φ19.17~φ19.32	φ16~φ16.15	
3		JT85G-P8TJ	230V/60Hz	9.73	33200	3.36	9.37	2.9	31.3	φ19.17~φ19.32	φ16~φ16.15	
3		JT118G-P8TJ	230V/60Hz	13.31	45400	4.44	12.5	3.06	43.4	φ19.17~φ19.32	φ16~φ16.15	
5		JT140G-P8TJ	230V/60Hz	15.47	52800	5.15	14.5	3.00	49.7	φ19.17~φ19.32	φ16~φ16.15	
5		JT160G-P8TJ	230V/60Hz	17.8	60700	5.81	17.2	3.06	56.8	φ19.17~φ19.32	φ16~φ16.15	
3	440~480V 三相 60Hz	JT71G-P8YD	460V/60Hz	8.13	27700	2.82	3.9	2.88	26.1	φ19.17~φ19.32	φ16~φ16.15	
3		JT85G-P8YD	460V/60Hz	9.73	33200	3.36	4.5	2.9	31.3	φ19.17~φ19.32	φ16~φ16.15	
3		JT118G-P8YD	460V/60Hz	13.31	45400	4.44	6.1	3.06	43.4	φ19.17~φ19.32	φ16~φ16.15	
5		JT140G-P8YD	460V/60Hz	15.47	52800	5.15	7.3	3.00	49.7	φ19.17~φ19.32	φ16~φ16.15	
3	575V 三相 60Hz	JT118G-P8YZN	575V/60Hz	13.31	45400	4.44	5.1	3.00	43.4	φ19.17~φ19.32	φ16~φ16.15	
5		JT140G-P8YZN	575V/60Hz	15.47	52800	5.15	5.75	3.00	49.7	φ19.17~φ19.32	φ16~φ16.15	

压缩机测试条件					
	蒸发温度	冷凝温度	过冷度	过热度	环境温度
压缩机	7.2℃	54.4℃	8.3℃	11.1℃	35℃

G型压缩机标准尺寸 R410A

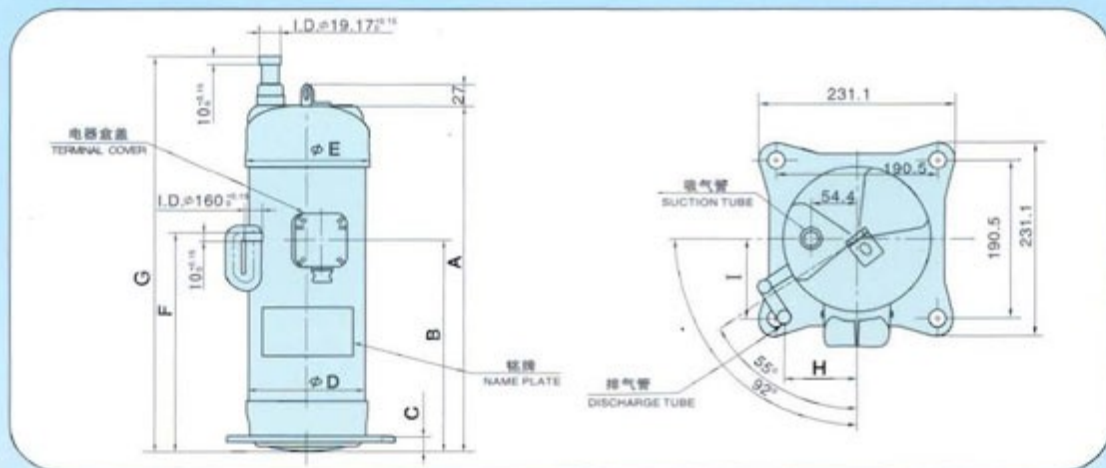

型号	A	B	C	D	E	F	G	H	I
JT90G-P8V1N(P8V1)	446	293.3	19.9	158	1654.6	259.5	506.1	77.1	88.5
JT125G-P8V1	471.3	322	21.3	168.5	176	324.6	531.4	81.4	90.5
JT125G-P8Y1	456.3	307	21.3	168.5	176	309.6	516.4	81.4	90.5
JT160(170)G-P8V1	468.5	312	21.3	168.5	176	314.6	528.6	81.4	90.5

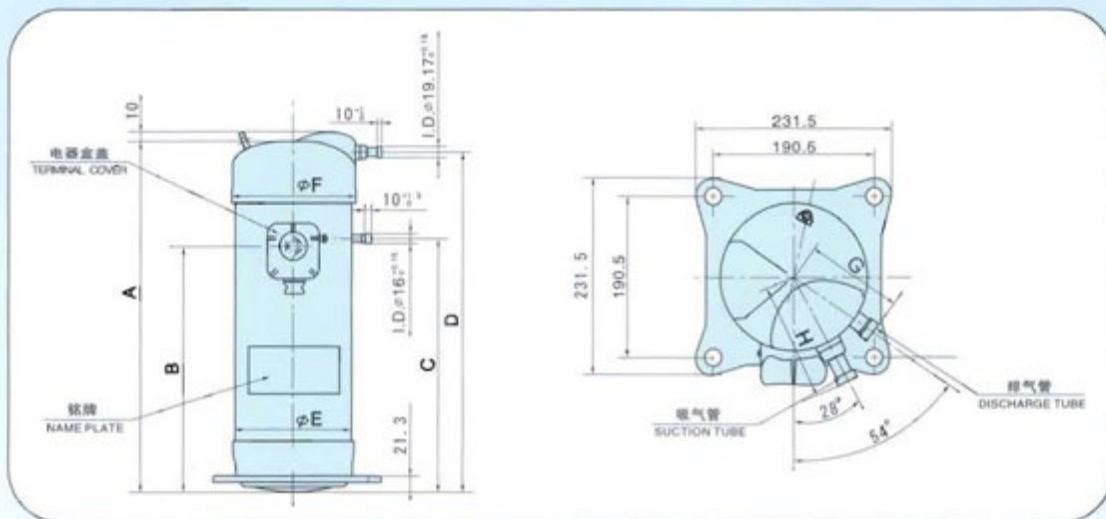

型号	A	B	C	D	E	F	G	H
JT71G-P8TJ(P8Y1)	436	283.3	288.9	416.1	159.8	165.6	114	137.8
JT85G-P8TJ								
JT71G(85G)-P8VD	446	293.3	298.3	426.1	159.8	165.6	114	137.8
JT71G(85G, 90G)P8VJ								
JT118GP8YD(P8YZN)	456.3	307	312.6	436.4	170.1	176	118.8	143
JT112G(118G, 125G)-P8VJ	471.3	322	327.6	451.4	170.1	176	118.8	143

D型压缩机型谱 制冷剂 R22

标称 HP	电 源	型 号	性 能						排量 cm ³ /r	管路连结		
			测定电源	制冷量		输入功率 KW	电流 A	COP (w/w)		吸气管mm	排气管mm	
				Kw	BTU/H							
7	380V 三相 50Hz	JT212D-Y1L	380V/50Hz	21.3	73400	6.56	11.3	3.25	117.3	φ25.4	φ19.1	
7.5		JT236D-Y1L	380V/50Hz	23.8	81900	7.27	12.4	3.27	131	φ25.4	φ19.1	
8.5		JT265D-Y1L	380V/50Hz	26.5	91100	8.03	13.7	3.3	144.7	φ31.8	φ19.1	
10		JT300D-Y1L	380V/50Hz	29.6	102000	8.94	15.2	3.31	163	φ31.8	φ19.1	
11		JT315D-Y1L	380V/50Hz	30.8	106200	9.24	15.7	3.33	169.5	φ31.8	φ19.1	
12		JT335D-Y1L	380V/50Hz	33.7	116000	10.08	17.2	3.34	184.2	φ31.8	φ19.1	
7	380-415V/440-440V 三相 50/60Hz	JT212D-YE	380V/50Hz	21.3	73400	6.56	11.3	3.25	117.3	φ25.4	φ19.1	
7.5			400V/60Hz	24.9	85700	7.74	11.9	3.22				
		JT236D-YE	380V/50Hz	23.8	81900	7.27	12.4	3.27	131	φ25.4	φ19.1	
400V/60Hz			28.1	96600	8.62	13.2	3.26					
8.5		JT265D-YE	380V/50Hz	26.5	91100	8.03	13.7	3.3	144.7	φ31.8	φ19.1	
			400V/60Hz	31.5	108500	9.55	14.6	3.3				
10		JT300D-YE	380V/50Hz	29.6	102000	8.94	15.2	3.31	163	φ31.8	φ19.1	
			400V/60Hz	34.9	120200	10.51	16.2	3.32				
12		JT335D-YE	380V/50Hz	33.7	116000	10.08	17.2	3.34	184.2	φ31.8	φ19.1	
			400V/60Hz	39.4	136900	11.92	18.4	3.34				
7		380-415V/440-440V 三相 50/60Hz	JT212D-P1YE	380V/50Hz	21.3	73400	6.56	11.3	3.25	117.3	φ25.4	φ19.1
				400V/60Hz	24.9	85700	7.74	11.9	3.22			
7.5			JT236D-P1YE	380V/50Hz	23.8	81900	7.27	12.4	3.27	131	φ25.4	φ19.1
				400V/60Hz	28.1	96600	8.62	13.2	3.26			
8.5			JT265D-P1YE	380V/50Hz	26.5	91100	8.03	13.7	3.3	144.7	φ31.8	φ19.1
				400V/60Hz	31.5	108500	9.55	14.6	3.3			
10			JT300D-P1YE	380V/50Hz	29.6	102000	8.94	15.2	3.31	163	φ31.8	φ19.1
				400V/60Hz	34.9	120200	10.51	16.2	3.32			
12	JT335D-P1YE		380V/50Hz	33.7	116000	10.08	17.2	3.34	184.2	φ31.8	φ19.1	
			400V/60Hz	39.4	136900	11.92	18.4	3.34				

压缩机测试条件					
	蒸发温度	冷凝温度	过冷度	过热度	环境温度
压缩机	7.2℃	54.4℃	8.3℃	11.1℃	35℃

D型压缩机型谱 制冷剂 R407C

标称 KW	电 源	型 号	性 能						管路连结		备 注	
			测定电源	制冷量		输入功率 KW	电流 A	cop (w/w)	排量 cm ³ /r	吸气管 mm		排气管 mm
				Kw	BTU/H							
7	380~415V三相 50Hz	JT212DA-Y1	380V/50Hz	18.9	64500	6.87	11.7	2.75	117.3	φ25.4	φ19.1	B
8.5	380~415V三相 50Hz	JT265DA-Y1	400V/50Hz	23.4	79800	8.36	14.1	2.8	144.7	φ31.8	φ19.1	B
10	380~415V三相 50Hz	JT300DA-Y1	400V/50Hz	26.5	90400	9.44	16	2.81	163	φ31.8	φ19.1	B
12	380~415V三相 50Hz	JT335DA-Y1	400V/50Hz	29.9	102000	10.7	17.9	2.79	184.2	φ31.8	φ19.1	B
10	380V三相 50Hz	JT300DA-Y1L	380V/50Hz	29.6	101000	9.55	16.4	3.1	163	φ31.8	φ19.1	A
12	380V三相 50Hz	JT335DA-Y1L	380V/50Hz	33.7	115000	10.81	18.3	3.12	184.2	φ31.8	φ19.1	A

压缩机测试条件

	蒸发温度	冷凝温度	过冷度	过热度	环境温度	备注
压缩机	7.2℃	54.4℃	8.3℃	11.1℃	35℃	A
	5℃	55℃	8℃	5℃	35℃	B

D型压缩机标准尺寸 R22/R407C

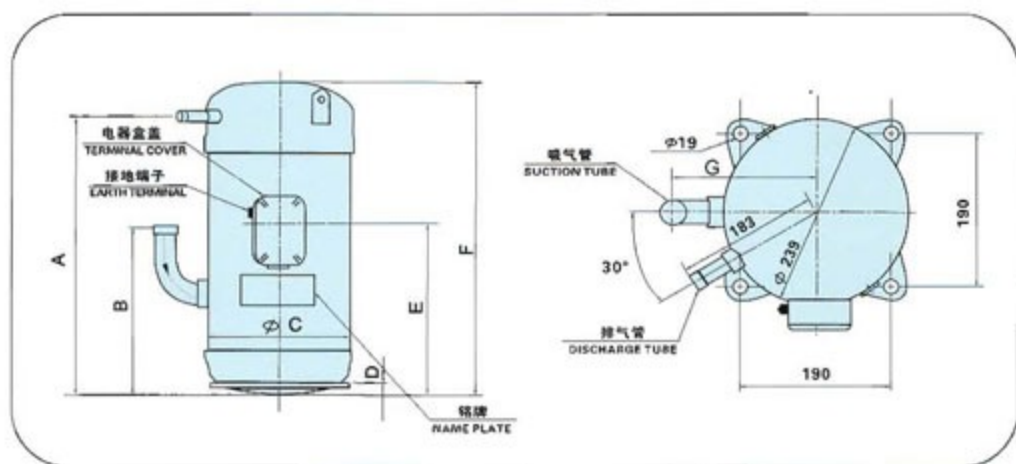

型 号	A	B	C	D	E	F	G
JT212(236)D-YE(Y1L) JT212(236)DA-Y1	450	277	288	20	275	512	171.5
JT212(236)D-P1YE	450	277	288	20	275	554.2	171.5
JT265-335D-YE(Y1L) JT265-335DA-Y1L(Y1)	462	277	288	20	275	524	182.5
JT265-335D-P1YE	462	277	288	20	275	566.2	182.5

D 型并联压缩机型谱 制冷剂 R22

标称 HP	电 源	型 号	性 能						排量 cm ³ /r	管路连结	
			测定电源	制冷量		输入功率 KW	电 流 A	COP (w/w)		吸气管mm	排气管mm
				Kw	BTU/H						
7	380V三相 50Hz	JT212D-TY1L	380V/50Hz	21.3	73400	6.56	11.3	3.25	117.3	φ25.4	φ19.1
7.5		JT236D-TY1L	380V/50Hz	23.8	81900	7.27	12.4	3.27	131	φ25.4	φ19.1
8.5		JT265D-TY1L	380V/50Hz	26.5	91100	8.03	13.7	3.3	144.7	φ31.8	φ19.1
10		JT300D-TY1L	380V/50Hz	29.6	102000	8.94	15.2	3.31	163	φ31.8	φ19.1
11		JT315D-TY1L	380V/50Hz	30.8	105000	9.24	15.7	3.33	169.3	φ31.8	φ19.1
12		JT335D-TY1L	380V/50Hz	33.7	116000	10.08	17.2	3.34	184.2	φ31.8	φ19.1
7	380-415V/400-440V 三相 50/60Hz	JT212D-TYE	380V/50Hz	21.3	73400	6.56	11.3	3.25	117.3	φ25.4	φ19.1
			400V/60Hz	24.9	85700	7.74	11.9	3.22			
7		JT236D-TYE	380V/50Hz	23.8	81900	7.27	12.4	3.27	131	φ25.4	φ19.1
			400V/60Hz	28.1	96600	8.62	13.2	3.26			
8		JT265D-TYE	380V/50Hz	26.5	91100	8.03	13.7	3.3	144.7	φ31.8	φ19.1
			400V/60Hz	31.5	108500	9.55	14.6	3.3			
10		JT300D-TYE	380V/50Hz	29.6	102000	8.94	15.2	3.31	163	φ31.8	φ19.1
			400V/60Hz	34.9	120200	10.51	16.2	3.32			
12		JT335D-TYE	380V/50Hz	33.7	116000	10.08	17.2	3.34	184.2	φ31.8	φ19.1
			400V/60Hz	39.4	136900	11.92	18.4	3.34			

压缩机测试条件					
	蒸发温度	冷凝温度	过冷度	过热度	环境温度
压缩机	7.2℃	54.4℃	8.3℃	11.1℃	35℃

D 型并联压缩机标准尺寸 R22



- 能力范围:7HP~12HP自由组合
- 可靠简单的均油设计
- 低噪音/低振动

D 型并联压缩机尺寸

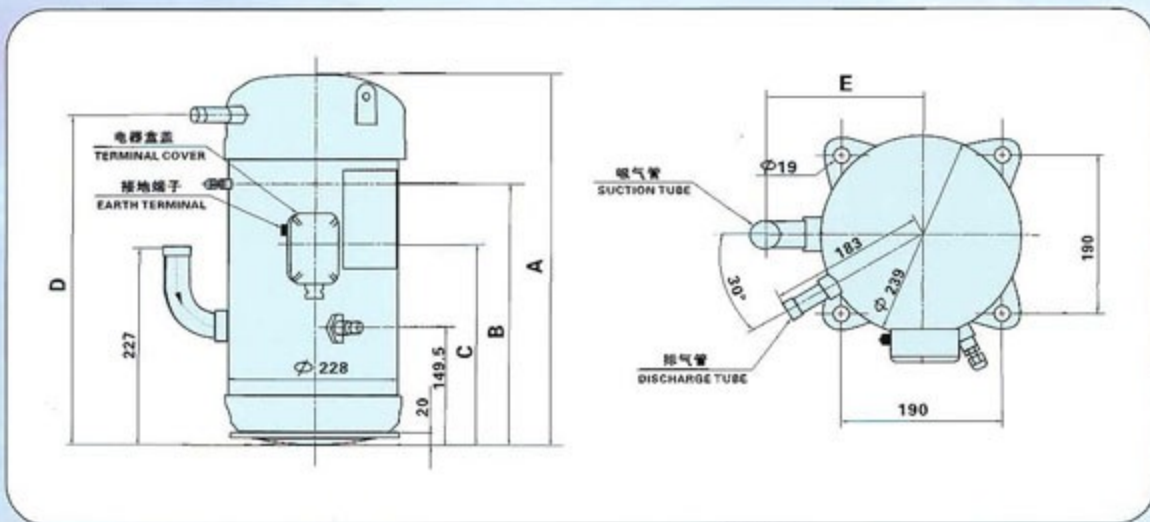

型号	A	B	C	D	E
JT212(236)D-TY1L(YE)	512	328	275	450	171.5
JT265(300,335)D-TY1L(YE)	524	340	287	462	182.5