

Simply a question of
better measurement



SCHMIDT® Flow Sensor SS 20.600

The powerful industrial professional
for demanding applications invol-
ving air and gases.

Industrial processes

Pneumatic technology

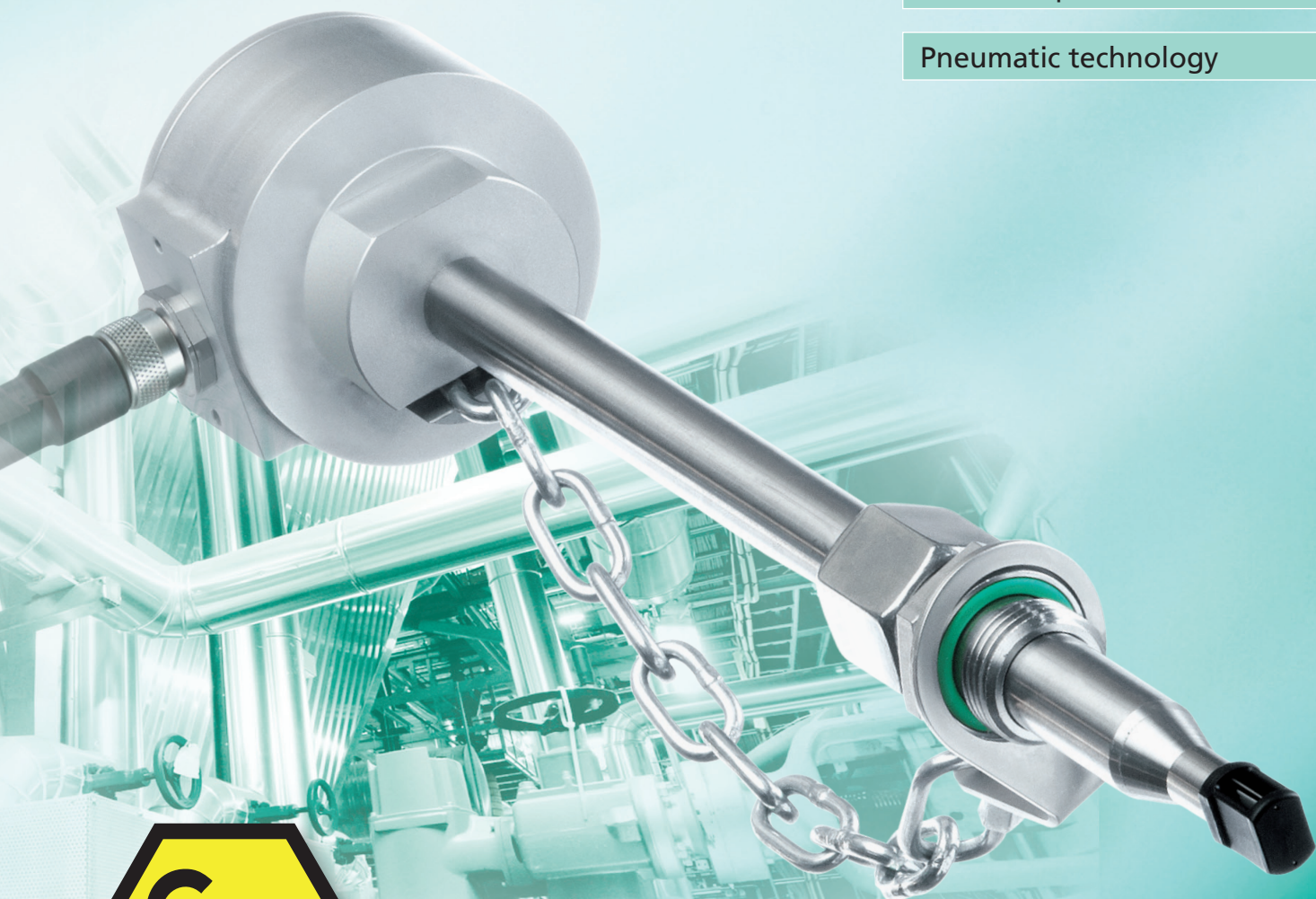



Flow rate volumes of gases – an important parameter in industrial processes

Measures to save energy and to assure quality in the production process are of particular importance in industrial processes. The ability to measure volumetric flow rates and volumetric flow of gases precisely has an important role to play in this. The requirements imposed on the flow rate sensor used for this are demanding: the sensor has to be capable of delivering precise measuring results for different gases, at high overpressures and across wide ranges of temperature. It also has to be able to do so under the most difficult environmental conditions such as explosive areas and in the open air. A further criterion involved in the selection of a suitable sensor is the prevention of maintenance and its attendant high secondary costs. Ease of assembly and reliable measuring values for many years: that is the objective.

The “true professional” for industrial processes and pneumatic technology

The thermal **SCHMIDT® Flow Sensor SS 20.600** is the perfect solution for demanding industrial applications. It can be used for a diverse range of applications, such as compressed air monitoring, gas monitoring on process burners, consumption recording of gases and a great deal more. The sensor records flow speed as well as media temperatures of up to 120 °C. It can be used in small tubes from DN 25 upwards and can involve a sensor length of up to 1 metre to measure the volumetric flow rate in large channels and ducts. If the standard version is not sufficient for overpressure of up to 16 bar, a version rated for up to 40 bar can be selected.

This sensor is very easy to install: screw down the sensor using the compression fitting included, align the sensor in the gas flow and centrally in the pipe, connect up its electrical wiring – and job done!

This sensor operates without any moving parts and employs a measuring principle that eliminates any drift or signs of ageing. This reduces the maintenance required for the sensor – depending on how contaminated the medium becomes – to the occasional need for the sensor head to be blown through (air blast) or rinsed in water.

High gas speeds, special gases or explosion protection? The **SS 20.600** can do (almost) everything!

The special chamber head sensor records flow speeds of 0.2 m/s up to 220 m/s. In order to obtain precise measuring results across this very broad speed range, every sensor is individually checked and compared in an elaborate pressurised wind tunnel.

To enable this sensor to be used in different gases, a range of individual versions is available, e. g. for pure oxygen, CO₂, methane. Of particular interest: Hydrogen will become an important parameter in future, and it can also be measured using the **SS 20.600** (option). For use in other media in potentially explosive atmospheres and environments, the sensor is optionally available in an explosion-protected version (ATEX).

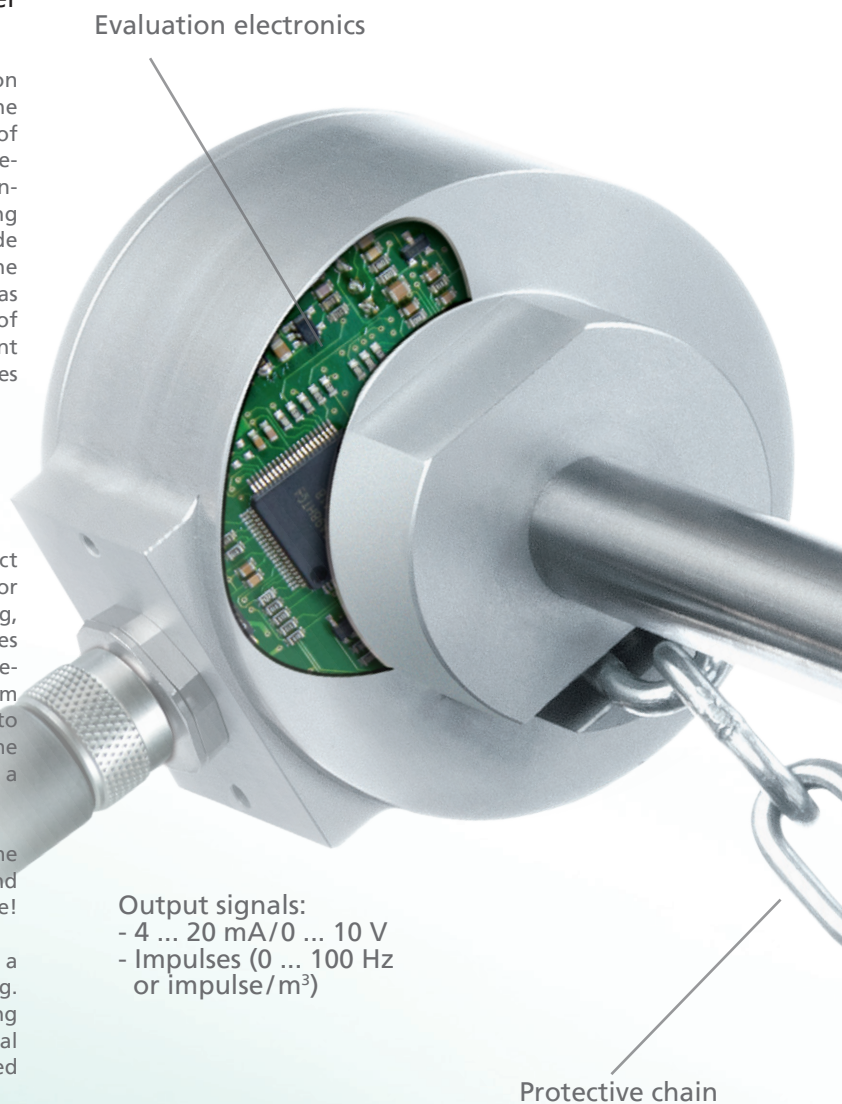

Practical examples

Branch	Application	The solution with SS 20.600
Industrial processes	Measurement of incoming air to control industrial burners/ incinerators	- High flow rate speeds of up to 220 m/s - Measurement of standard volumetric flow rate independent of pressure and temperature - O ₂ version for pure oxygen
	Recording of inert gas volumes (nitrogen)	- Specific versions for gas and gas mixtures - Resistant to overpressure up to 40 bar
	Control of combustion gas volume (natural gas, methane, ...)	- ATEX version - For pipe diameters from DN 25
	Detection of gas consumption	- Acquisition of the flow rates of "almost zero" to the maximum value (detection gas slippage) - From - 40 °C temperature of medium usable (ATEX version)
Pneumatic technology	Compressed air consumption, compressor control	- Extremely wide measuring ranges for flow rate - Simple signal processing: impulse per m ³
	Leakage measurement	- Measurement from 0.2 m/s - Design principle eliminates age-dependent drift
	Monitoring of minimum flow rate	- High-precision adjustment (1 % precision) - Very fast response speed

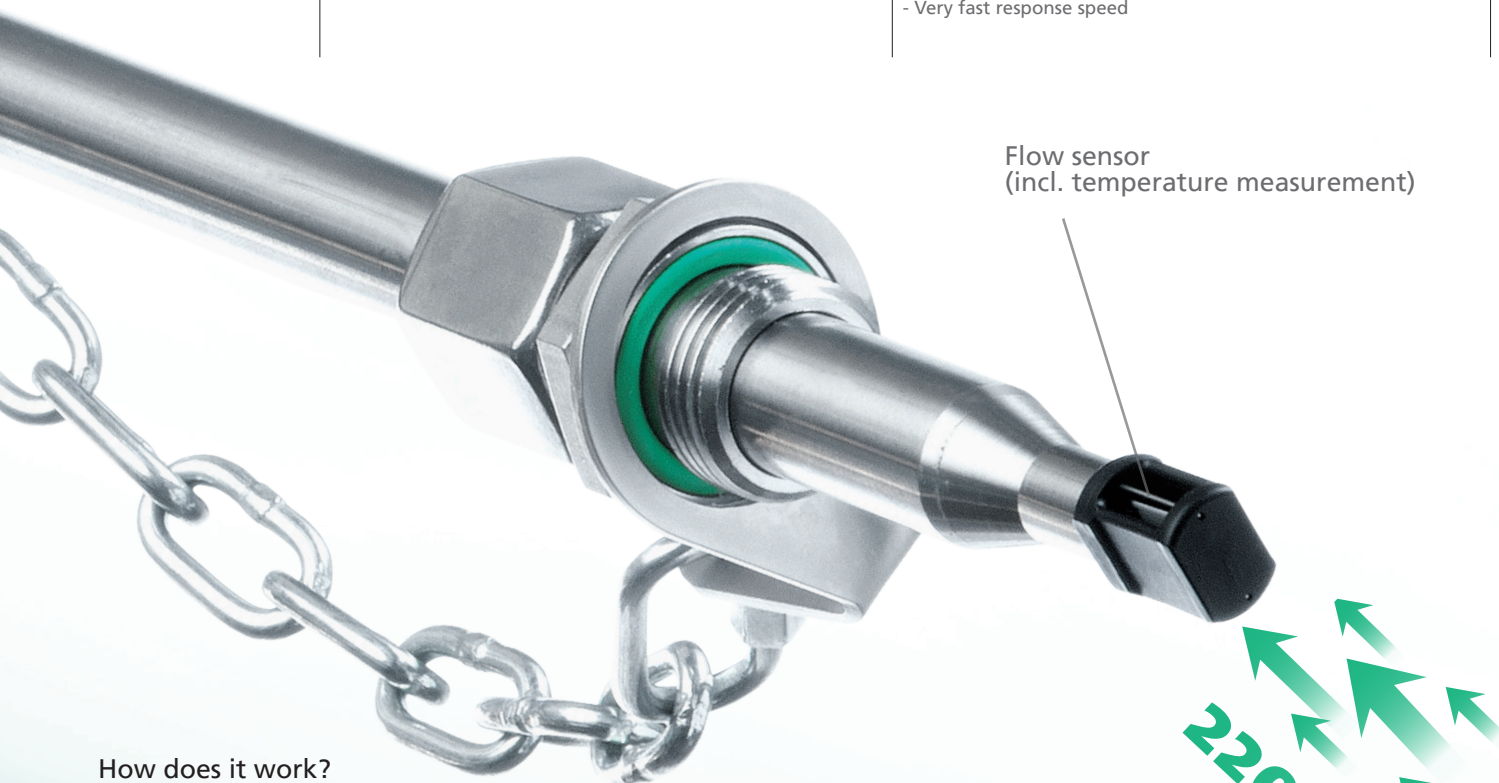

How does it work?

The flow sensor element is protected, and is positioned in the chamber head in a way that favours unimpeded flow. Sensors for flow rate as well as temperature are arranged on the ceramic sensor element. For protection purposes, sensors are coated with a thin layer of glass. The flow sensor is heated to 40 K above the temperature of the medium. The power required to maintain this positive temperature differential ("overtemperature") is an indicator for the flow rate speed that the sensor issues as "normal speed" (linear current/voltage/impulse signal). This is a great advantage of the measuring principle: No additional measurement of the pressure or temperature of the medium is required.

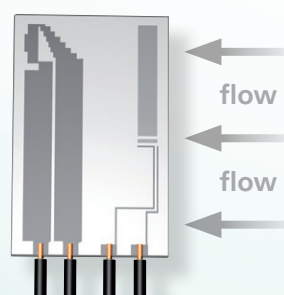



Individually adapted to suit every application – you have the choice!

For optimum installation in the various different pipe diameters, 4 standard sensor lengths as well as special lengths of 120 to 1,000 mm can be selected. A remote version is available for difficult installation conditions. The probe length itself and the cable length between sensor and housing can be selected.

To enable the sensor to be adapted to flow rate conditions, 6 standard measuring ranges are available, extending up to 220 m/s. The volumetric flow rate is the result of the flow rate speed, multiplied by the pipe cross-sectional surface area and a profile factor. However, customer-specific measuring ranges can also be supplied in increments of 0.1 m/s. The advantage of this is that a desired maximum volumetric flow rate determines the measuring range of the sensor depending on pipe diameter. Example: Maximum volumetric flow rate of 450 m³/hr with a pipe diameter of DN 65 yields a maximum flow rate measuring range for the sensor of 48.1 m/s (= 20 mA or 10 V). For the purposes of simple conversion, the homepage features a flow rate calculator that also determines the profile factor, which is dependent on the pipe cross section.

For evaluation systems with impulse inputs, the **SS 20.600** offers an additional impulse output for the flow rate signal. There is a standard measuring range of 0... 100 Hz available or, if the pipe diameter is indicated, impulses per m³ as a customer-specific output as an option.

Measure other gas media too? Absolutely!

More often than not, the medium being measured is not air, but instead comprises other gases or gas mixtures. For these special applications, gas-specific versions of the **SS 20.600** can be supplied. With these versions, the sensor has a specific correction – based on adjustment in air – programmed in. These correction factors were established individually for each gas on real gas channels. For gas mixtures, each correction is calculated on the basis of an individual customer specification. For media with an oxygen content of > 21 % of volume all components in contact with the media must be cleaned to remove greases, oils and/or other combustible elements. A specific grease-free and O₂ > 21 % variant provides the required safety for this application.

Accuracy – in black & white

As an option, the **SS 20.600** can be supplied with a high precision adjustment for air that can also be used for pure oxygen and nitrogen. This measurement is carried out at **SCHMIDT Technology**. The high levels of precision and reproducibility are documented in an ISO calibration certificate (attached). This calibration can be renewed to suit user definitions.



Everything in view

The LED display is dual function. In "normal" operation the 4x LED's illuminate steady green in sequence. In "fault" condition reportable faults are indicated by red flashing LED's. The instrument will output V and mA and change-over is automatic.

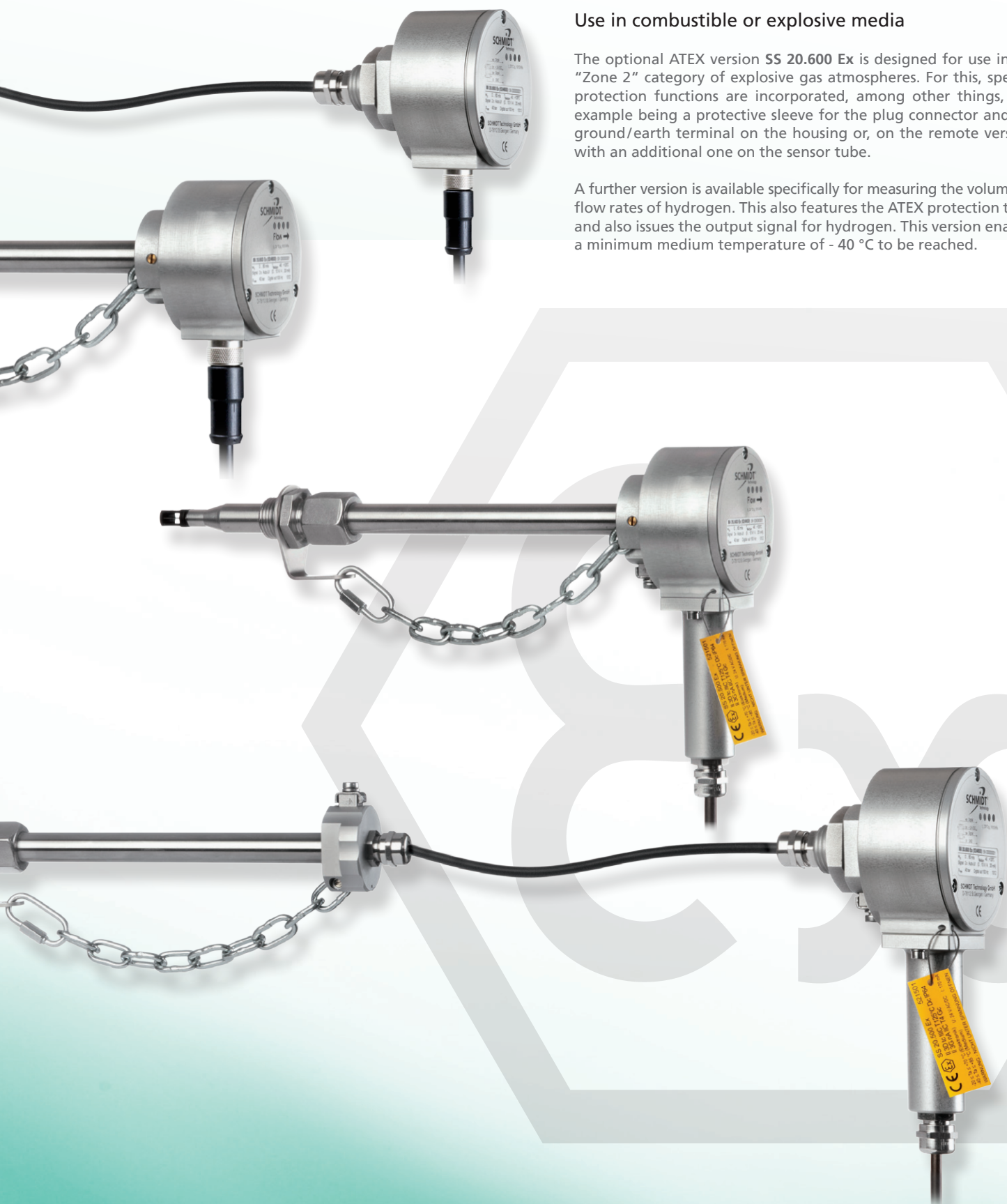

Use in combustible or explosive media

The optional ATEX version **SS 20.600 Ex** is designed for use in the "Zone 2" category of explosive gas atmospheres. For this, specific protection functions are incorporated, among other things, one example being a protective sleeve for the plug connector and the ground/earth terminal on the housing or, on the remote version, with an additional one on the sensor tube.

A further version is available specifically for measuring the volumetric flow rates of hydrogen. This also features the ATEX protection type, and also issues the output signal for hydrogen. This version enables a minimum medium temperature of $-40\text{ }^{\circ}\text{C}$ to be reached.

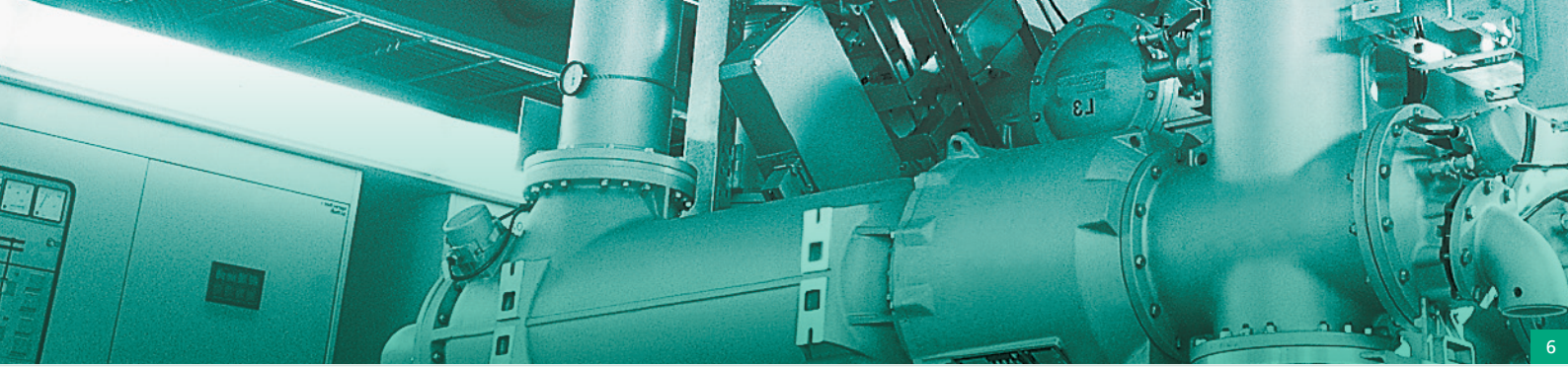

Dimensions of the basic sensor

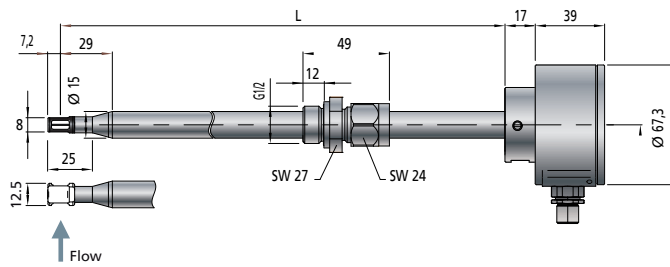

ATEX version SS 20.600 Ex (optional)

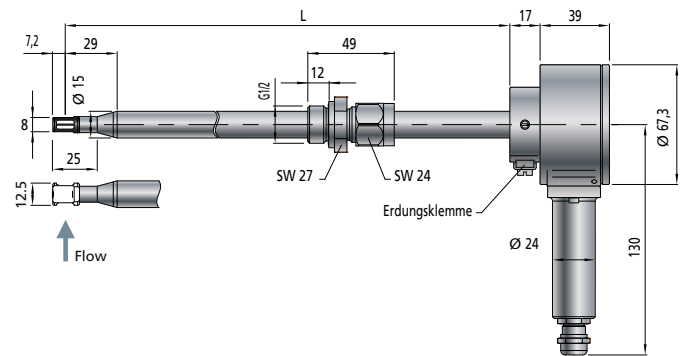

Remote sensor including wall mounting bracket

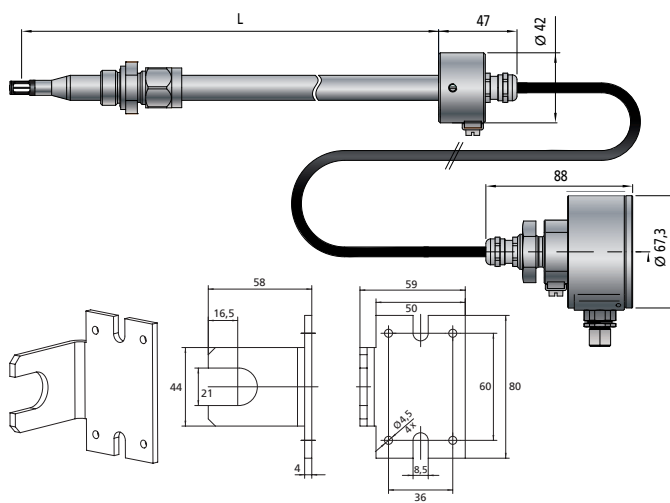

Remote sensor, ATEX version (optional) including wall mounting bracket

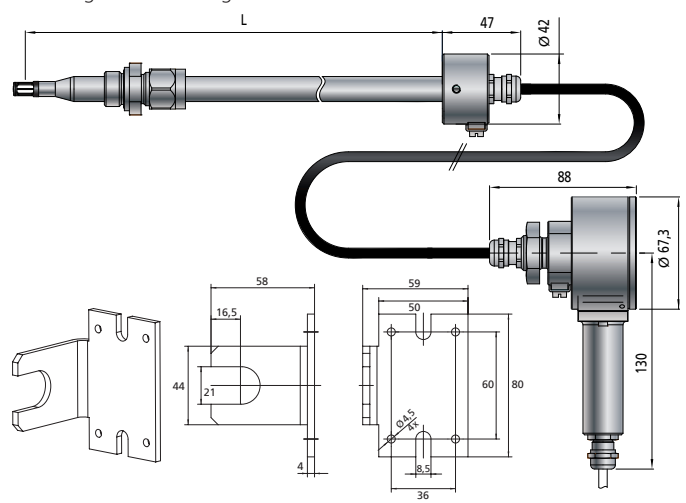

Mounting instructions

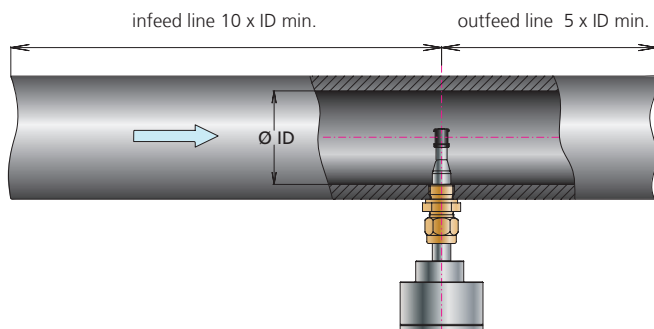

Mounting parameters

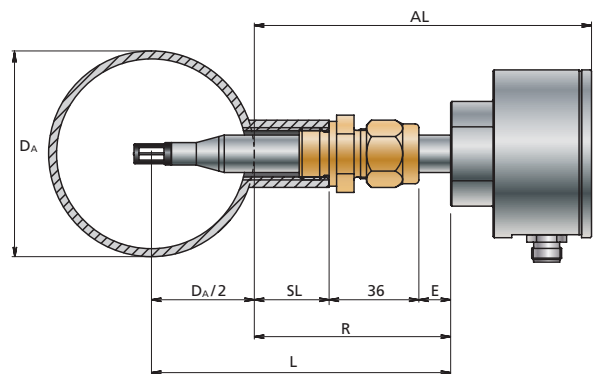

- DA = Outer diameter of tube
- SL = Length of welding sleeve
- E = Adjustable length of sensor tube
- AL = Extended length of compact sensor
- R = Reference length
- L = Length of sensor
- All dimensions in mm



Technical Data

Measuring data	
Measuring quantity w_N	Standard flow velocity w_N normalized to 20 °C and 1,013.25 hPa
Measuring fluid	Air or nitrogen; optional: Natural gas, biogas, CO ₂ , hydrogen and specialty gases and gas mixtures
Measuring range flow w_N	0 ... 10/20/60/90/140/220 m/s; optional: customised measuring ranges in 0.1 m/s-steps
Lower detection limit w_N	0.2 m/s
Measuring range temperature T_M	-20 ... +120 °C; SS 20.600 EX: -40 ... +120 °C
Accuracy	
Standard w_N	±3 % of measured value + (0.4 % fmr; min. 0.08 m/s)*
High precision w_N (optional, for Air, nitrogen, oxygen only)	±1 % of measured value + (0.4 % fmr; min. 0.08 m/s)*
Repeatability w_N	±1 % of measured value
Response time $t_{90} w_N$	1 s (jump from 0 to 5 m/s air)
Temperature gradient w_N	< 8 K/min at $w_N = 5$ m/s
Measurement accuracy temperature T_M	±1 K (10 ... 30 °C); ±2 K remaining measuring range (@ $w_N > 5$ m/s)
Operating temperature	
Sensor	-20 ... +120 °C; SS 20.600 EX: -40 ... +120 °C
Electronics	-20 ... +70 °C
Storage temperature	-20 ... +85 °C
Material	
Housing	Aluminium, anodized
Sensor tube, screw connection	Stainless steel 1.4571
Sensor head	Platinum resistor element (glass-passivated), PPO / PA
Protective sleeve	Aluminium, anodized
Sensor cable (on remote sensor)	Jacket PUR, halogen-free, UL
General Data	
Medium, environment	Non-condensing (up to 95 % rH)
Maximum pressure	16 or 40 bar
Display	4 x Duo LEDs green/red/orange
Supply voltage	24 VDC ±20 %
Current intake	Approx. 50 mA (without impulse outputs); max. 250 mA
Analogue outputs for temperature and flow rate Auto U/I	0 ... 10 V / 4 ... 20 mA (protected against short circuits) Voltage output: > 550 Ω Current output: < 500 Ω Hysteresis: 50 Ω
Impulse outputs	Frequency 0 ... 100 Hz, optional: 1 impulse/1 m ³ ; 1 impulse/0.1 m ³ /h; 1 impulse/0.01 m ³ /hr (max. 100 Hz) 1. Highside driver to supply voltage (not galvanically isolated) 2. Semiconductor relay (galvanically isolated); max. 30 V / 50 mA High level: > supply voltage - 3 V Short circuit current limitation: 100 mA
Electrical connection	Plug-in connector M 12, screwed, 8-pin
Maximum line length	Voltage signal: 15 m, current signal/Impulse: 100 m
Mounting position	Any, (with vertical downdraft: lower limit of measuring range 2 m/s @ 16 bar)
Installation tolerance	±3° to the flow direction
Minimum immersion depth	20 mm
Type/class of protection	IP 65 (housing), IP 67 (sensor) / III or PELV
ATEX category	II 3G Ex nA ic IIC T4 Gc
Sensor length	Compact sensor: 120 / 250 / 400 / 600 mm; special lengths of sensor from 120 to 1,000 mm
Weight	Approx. 500 g max. (without connection cable)

* under reference conditions, related to adjustment reference

Accessories

SCHMIDT® Probe ball valve

(see separate brochure)

A choice of probe ball valves are available to facilitate fast removal and installation in 1" to 2" pipework. Advantage: even while the system is under pressure, it is no problem to install or remove the sensor.

A straight-run ball valve is available for larger pipework diameters.

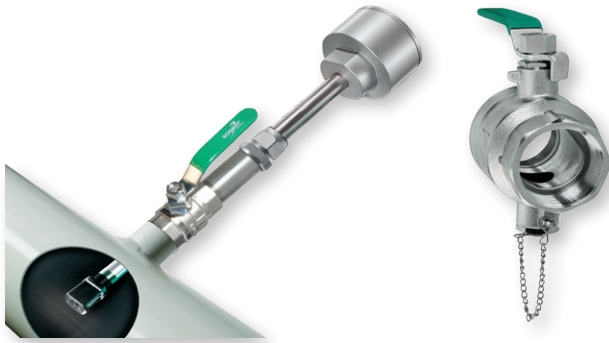

LED measured value display

(see separate brochure)

For visualization purposes directly on location, an LED unit is available to display measuring values.

The advantages:

- Display in m/s or m³/h
- Programmable output signal
- Two programmable relay outputs
- Power supply: 85 – 250 V AC or 24 V DC
- Power supply to the connected sensor
- Separate version with "sum" function
- Detection of flow direction by the use of two SS 20.600 units arranged at 180° to one another

Extended connection options with field bus modules

(available from Q4, 2012)

As an option, the following variants are available for integrating the SS 20.600 into existing BUS systems:

- DeviceNet
- ProfiBUS DP
- Others on request

The BUS modules are housed in a rugged auxiliary housing. The standard outputs are available in addition to the BUS signal.



Shielded connection cable available in various lengths



Coupler socket with screw type terminals
Type no. 524 929



Welding steel sleeves Type no. 524 916
or stainless steel Type no. 524 882

Order information for the SCHMIDT® Flow Sensor SS 20.600

	Description	Article number										
		524 600	A	B	C	D	E	F	G	H	PP	
Basic sensor	SCHMIDT® Flow Sensor SS 20.600; output signal 4 ... 20 mA and 0 ... 10 V; impulse output, incl. pressure-tight stainless steel compression fitting											
	Optionen											
Mechanical type	Sensor length 120 mm		1									
	Sensor length 250 mm		2									
	Sensor length 400 mm		3									
	Sensor length 600 mm		4									
	Special lengths (> 120 mm to 1,000 mm): Length: ____ mm		8									
	Remote sensor incl. wall mounting bracket (length: ____ mm) or (selectable lengths: 120/250/400/600 mm) and cable (length: ____ m, max. 10 m)		9									
	Pressure-tight compression fitting, stainless steel G½			1								
	Pressure-tight compression fitting, stainless steel R½ (PT)			2								
Measuring ranges ¹ and calibration	Measuring range 0 ... 10 m/s				1							
	Measuring range 0 ... 20 m/s				2							
	Measuring range 0 ... 60 m/s				3							
	Measuring range 0 ... 90 m/s				4							
	Measuring range 0 ... 140 m/s				5							
	Measuring range 0 ... 220 m/s				6							
	Special measuring range (10 ... 220 m/s) in 0.1 m/s-steps: ____, ____ m/s				9							
	Standard adjustment					1						
	High-precision adjustment check incl. ISO calibration certificate					2						
	Standard adjustment check with conversion factor for methane ²⁾ Wn max: 90 m/s					3						
	Standard adjustment check with conversion factor for biogas (60% methane, 40% CO ₂) ²⁾ Wn max: 35 m/s					4						
	Standard adjustment check with conversion factor for CO ₂ ²⁾ Wn max: 60 m/s					5						
	Standard adjustment check with conversion factor for H ₂ ²⁾					6						
	Standard adjustment check with conversion factor for special gases and mixtures ²⁾					9						
Impulse output	Standard 100 Hz (= final value of measuring range w _N)						1					
	1 impulse / 1 m ³ for pipe diameter (round) ____ mm						2					
	1 impulse / 0.1 m ³ for pipe diameter (round) ____ mm						3					
	1 impulse / 0.01 m ³ for pipe diameter (round) ____ mm						4					
Additional outputs	Without communications module							1				
	Communications modules for Modbus, DeviceNet, ProfiBUS (from Q4, 2012)							*				
Protection type ATEX	Without ATEX design (SS 20.600)									1		
	ATEX design (SS 20.600 EX) ²⁾									2		
Protection type, grease-free; O ₂	Standard application										1	
	Grease-free and for O ₂ > 21 % ²⁾										2	

* On request

¹⁾ To select the appropriate measurement range please use our flow calculator tool on www.schmidttechnology.de

²⁾ Not available in combination with the option "special lengths"

Order information SCHMIDT[®] Flow Sensor SS 20.600

	Description	Article number
Accessories	Connecting cable, 8 pole, length 5 m, with coupler socket and open cable end	524 921
	Connecting cable, 8 pole, length selectable, with cable end sleeves, free of halogen	524 942
	Coupler socket, 8 pole, with screw terminals, for cable ϕ 6 ... 8 mm	524 929
	Welding sleeve steel G ½ acc. to EN 10241, 5 pieces	524 916
	Welding sleeve stainless steel 1.4571 G ½ acc. to EN 10241, 2 pieces	524 882
	Power supply unit 24 V DC	535 282
	SCHMIDT [®] LED display MD 10.010; in wall housing to show the volume flow and flow velocity, 85 ... 250 V AC and sensor supply	527 320
	SCHMIDT [®] LED display MD 10.010; similar to 527 320, but with 24 V DC voltage supply	528 240
	SCHMIDT [®] LED display MD 10.015; in wall-mounted housing, similar to 527 320 but with additional sum function and second measuring input	527 330
	SCHMIDT [®] LED display MD 10.015; similar to 527 330, but with 24 V DC voltage supply	528 250
	Assembly kit for pipe assembly, suitable for MD 10.010 / 10.015, including pipe clamps and collar for adjustment to the pipe diameter	531 394
	Probe ball valve 1" inside thread, connection to flow sensor: ½" inside thread incl. plug and chain	530 940
	Probe ball valve 1 ¼" inside thread, connection to flow sensor: ½" inside thread incl. plug and chain	530 941
	Probe ball valve 1 ½" inside thread, connection to flow sensor: ½" inside thread incl. plug and chain	530 942
	Probe ball valve 2" inside thread, connection to flow sensor: ½" inside thread incl. plug and chain	530 943
	Straight-run probe ball valve ¾" inside thread, with threaded adapter for ½" full-length screw connection ¾"	532 355
	Welded socket, steel, outside thread ¾", 5 pieces	531 200
Welded socket, stainless steel, outside thread ¾", 2 pieces	531 201	

SCHMIDT Technology GmbH

Feldbergstraße 1
78112 St. Georgen/Germany

Phone +49 77 24/8990
Fax +49 24/89 91 01

sensors@schmidttechnology.de
www.schmidttechnology.de