

Smart temperature transmitter APT-2000ALW

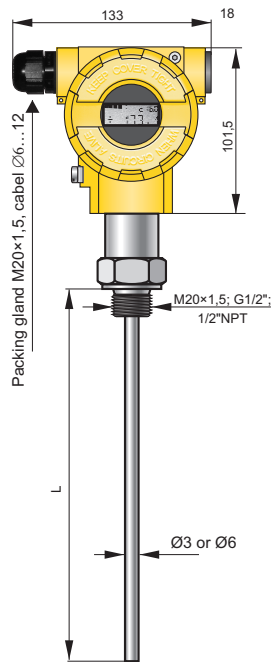

- ✓ 4...20 mA output signal + HART protocol
- ✓ Programmable range, zero shift, characteristic and damping ratio with local panel keys
- ✓ ATEX Intrinsic safety , ATEX Explosion proof
- ✓ Resistant or thermocouple measuring element
- ✓ MID (Measuring Instruments Directive) – certificate acc. to 2004/22/WE directive and OIML R140:2007 recommendations.



APT-2000ALW/GB

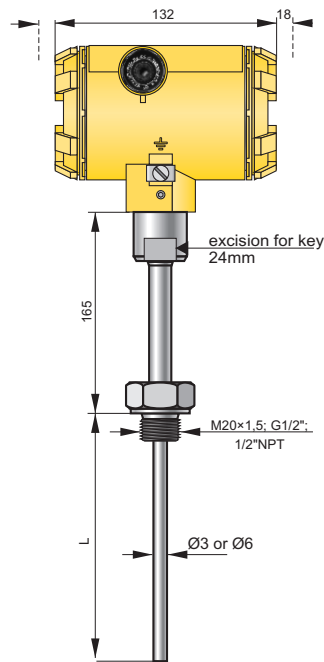

APT-2000ALW/GN

Thermowell

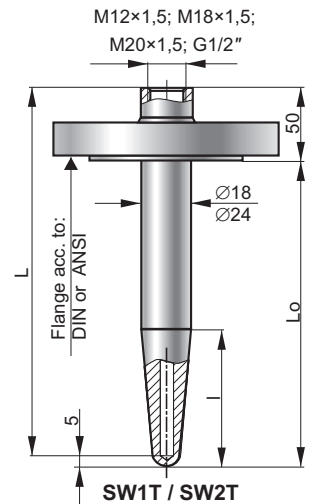
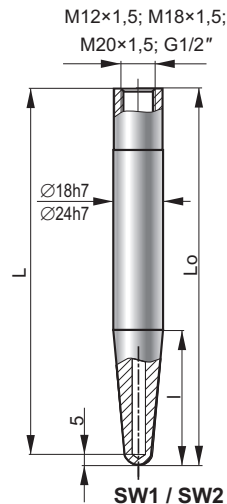
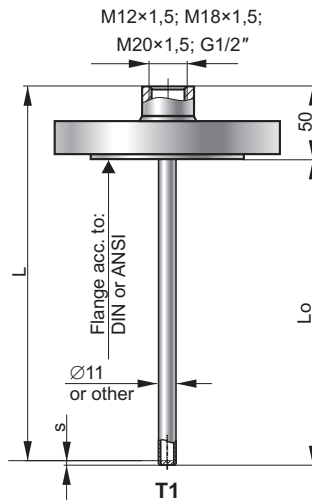
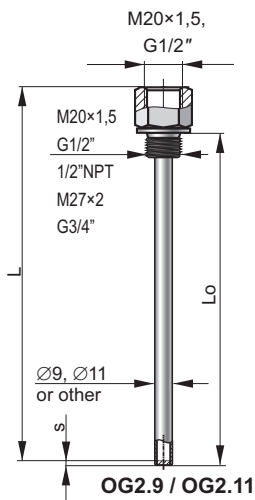

Technical data Metrological parameters

Error (digital value)

± (0,2 + 0,002·|t|)°C for Pt100 sensor
 ± 1,5°C for TC type K sensor and t ≤ 375°C
 ± (0,004·t)°C for TC type K sensor and t > 375°C

Additional error for analog output ±0,04%·z

where:

|t| – absolute value of the measured temperature °C

t - value of the measured temperature °C

z – transmitter setting range °C

Measuring range

Sensor type	Min set range	Nominal range
Pt100	10°C	-200...550°C*
K	10°C	-40...550°C

* for GB version -50...150°C

Electrical parameters

Power supply 12...55 V DC (Ex 13,5...28 V)

Additional voltage drop

when display illumination switched on 3 V

Output signal 4...20 mA + Hart protocol

Resistance required for communication (HART)

min. 240Ω

Load resistance

$$R[\Omega] = \frac{U_{ZAS}[V] - 12V}{0,0225A}$$

* – 15 V when display illumination switched on

Operating conditions

Ambient temperature -40...85°C
 for version with Ex ia -40...80°C
 for version with Ex d -40...75°C

Min. immersion length L=100mm

Materials

Casing Aluminium,
316Lss- special version

Sensor material 321ss

Thermowell according to table page.

Communication and configuration

The communication standard for data interchange with the transmitter is the Hart protocol.

Communication with the transmitter is carried out with:

- a KAP-03, KAP-03Ex communicator,
- some other Hart type communicators,
- a PC using an HART/USB converter and Raport 2 configuration software.

The data interchange with the transmitter enables the users to:

- identify the transmitter;
- configure the output parameters;
- read the currently measured temperature value of the output current and the percentage output control level;
- force an output current with a set value;
- calibrate the transmitter in relation to a model temperature.

Standard thermowell data

Thermowell type		Standard dimensions of thermowell						Thermowell material	Available process connection	
		Ø[mm]		L[mm]		l[mm]				
OG2.9		9x1		100, 160, 250, 400		-		316Lss	M20x1,5; G½"; ½"NPT	
OG2.11		11x2		100, 160, 250, 400		-		316Lss	M20x1,5; G½"; ½"NPT	
T1		11x2		100, 160, 250, 400		-		316Lss	Flange according to DIN and ANSI	
SW1	SW2	18h7	24h7	100 140 200	140 200	35 65 65	65 65	15HM, 10H2M 316Lss	-	
SW1T	SW2T	18h7	24h7	100 140 200	140 200	35 65 65	65 65	15HM, 10H2M 316Lss	Flange according to DIN and ANSI	
SW1G	SW2G	18h7	24h7	100 140 200	140 200	35 65 65	65 65	15HM, 10H2M 316Lss	M20x1,5, G1/2"	M27x1,5, G3/4"

Ordering procedure

APT-2000ALW/___/___/___/___/ L = mm / ___ / ___ ÷ ___ °C / ___ / ___

Special version:

Exia - ATEX certificate

⊕ II 1/2G Ex ia IIC T4/T5/T6 Ga/Gb

Exia(Da) - ATEX certificate

⊕ II 1/2G Ex ia IIC T4/T5/T6 Ga/Gb
 II 1D Ex ia IIC T105°C Da
 I M1 Ex ia I Ma (version with SS housing)

Exd - ATEX certificate

⊕ II 1/2G Ex ia/d IIC T* Ga/Gb
 II 1/2D Ex ia/t IIIC T* Da/Db
 I M2 Exd ia I Mb (version with SS housing)
 T* - temperature class transmitter (for gas)
 or maximum surface temperature (for dust)

SS - Housing material 316SS

IP67, IP66/67

Version: **GB, GN**

Thermowell type: according to table

Type of thread of flange connection:
M20×1,5; G1/2"; 1/2"NPT or flange

Immersion length

Type of measuring element: **Pt100, K**

Set measuring range

Alarm signal: 3,8 or 23 mA

Electrical connection: **without marking** (M20x1,5) or **US** (1/2"NPTF)

SMART TEMPERATURE TRANSMITTER APT-2000ALW with MID

Application

Smart temperature transmitters APT-2000ALW MID is applicable to the measurement of the temperature in application designed according to directive 2004/22/WE (MID), harmonized standard PN-EN12405-1:2005 + A2:2010 and recommendation OIML R140:2007. Device subcomponent suitable for custody transfer measurement of gas with MID approval. Mechanical construction and installation of the transmitter enclosure shall comply with the transmitter APT-2000ALW are described on page IX/ 2, IX/ 3 of catalogue. Transmitter due to factory blockade of transmitter's configuration cannot be configurable by user. Electrical connection of the transmitter is according to drawing on page IX/ 3. Available are only terminals SIGNAL + and SIGNAL -. Temperature transmitter APT-2000ALW MID are produce with GB type of sensor and with resistant sensor Pt100.

Note! For custody transfer applications, the cover clamp screws have to be locked with seal wire.

Metrological parameters

Max. permissible error according to EN12405-1 (calculated in relation to the measured value)

- in reference conditions
 20±3°C(±1 during the measurement) ≤ 0,1%
 - nominal operating conditions < 0,2%
 - special version < 0,1%

Long-term stability < 0,2% / 5 years

Operating temperature range -25...55°C

Immersion length 150...290mm

Power supply Exia: 13,5...28VDC

Exd: 13,5...45VDC

MID Parts Certificate No. 28/12

Exia: ⊕ II 1/2G Ex ia IIC T4/T5/T6 Ga/Gb

Exd: ⊕ II 1/2G Ex ia/d IIC T* Ga

Measuring range

Measuring range: -20...60°C

Ordering procedure

APT-2000ALW/MID/___/___/ L = mm

Special version:

Exia - Intrinsic safety version (ATEX)

Exd - Explosion proof version (ATEX)

SS - Housing material 316SS

Process connection type: **M20x1,5 , G1/2"**

Immersion length