

Installation Instructions

Joint System: 112, 113, 113A-A07/A09

Note: Verify that the structural gap is in conformance with submittal data before beginning installation. If this is a Fire Rated Assembly, the fire barrier must be installed before the Architectural Joint System. Refer to the fire barrier instructions for specific system installation.

Fig. 1 (112-A07 Wall to Wall shown)

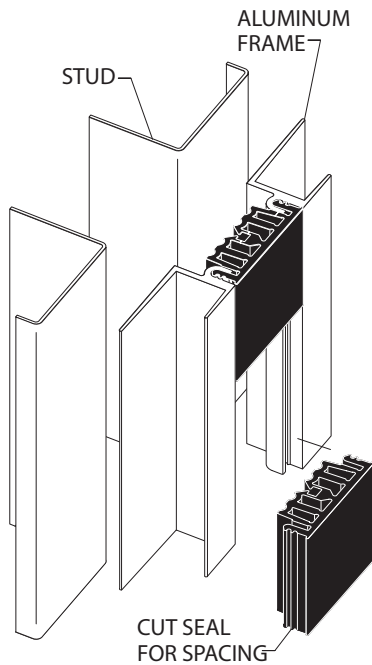

(113-A07 Wall to Wall shown)

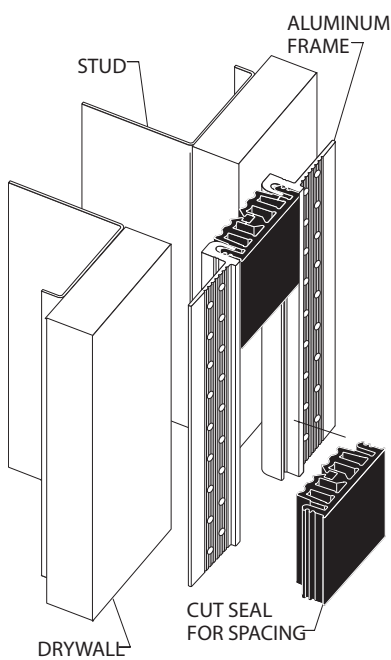

1. Install the architectural joint system on a level wall surface. For 112 systems, this may require shims between metal stud and aluminum frame. For 113 systems, even drywall with leveling compound to raise the tops of the frames.

Figure 1

2. Cut the aluminum frames to the desired length.
3. To properly space frames, cut three small 2" [50mm] sections of seal. Insert one at each end and one in the center of each set of frames. With the pre-assembled 113A-A07 system, insert the entire assembly into the gap.
4. Center the frame assembly over the structural gap. Align plumb.
 - 4a. For wall to corner systems, place the assembly into the structural gap so the recessed frame is firmly against the corner wall. Align plumb, making sure the tops of the frames are level. Transfer the location of the top edge of the recessed frame to the wall using a marker. For proper spacing on the 113 series, several mounting holes on the wall frame should also be marked (see Figure 1a).

Fig. 1a (113-A09 Wall to Corner shown)

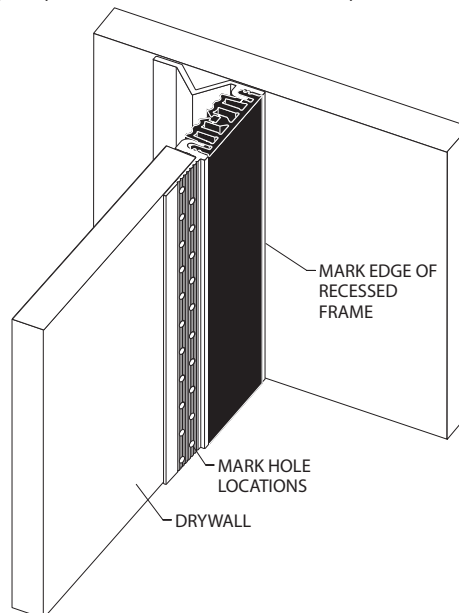

IPC.810/REV.4

JOINTMASTER® Expansion Joint Systems

inpro.com • 800.222.5556 • 262.679.9010

World Headquarters S80 W18766 Apollo Drive, Muskego, WI 53150 USA

Installation Hotline: 866.394.6776

inpro®

Installation Instructions

Joint System: 112, 113, 113A-A07/A09

Fig. 2 (112-A07 Wall to Wall shown)

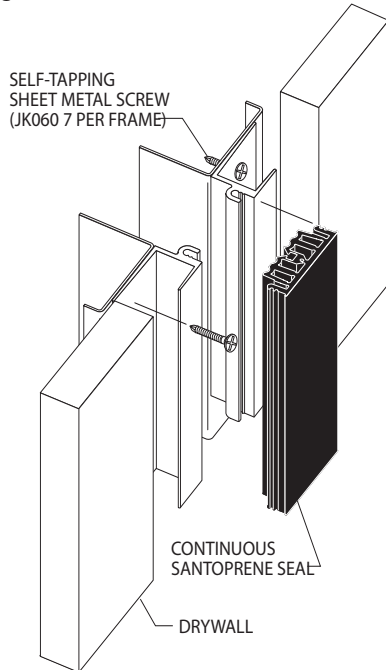

Fig. 3 (112-A07 Wall to Wall)

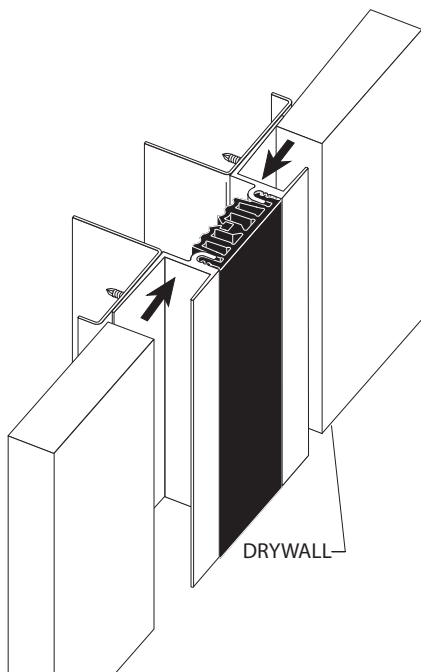

Figure 2

5. Drill holes through the frames into substrate approximately 18" [457] on center starting 6" [253mm] from each end.
 - 5a. Secure 112 system frames using JK060 self tapping sheet metal screws.
 - 5b. Secure 113 system frames using JK061 self tapping sheet metal screws.
6. Remove the temporary spacers.
7. Press the Santoprene seal into the recessed slots of the frames until the seal is flush with the tops of the frames.

NOTE: To assist in installing the seal, apply a mist of soapy water solution to the back of the seal. A 1" wide seam roller may be used to fully engage the seal ears into the frame slots.

Figure 3

8. For 112 systems, insert drywall into the wall frame. For 113 systems, feather joint compound away from wall frame edge to smooth adjacent finishes. Clean the exposed surfaces with a non-solvent cleaner, such as 409, as required.

(113-A07 Wall to Wall completed installation)

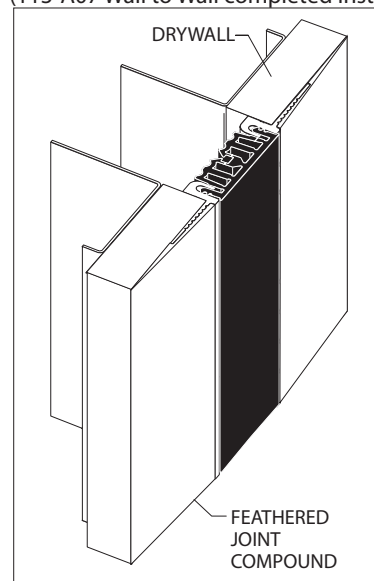

JOINTMASTER® Expansion Joint Systems

inpro.com • 800.222.5556 • 262.679.9010

World Headquarters S80 W18766 Apollo Drive, Muskego, WI 53150 USA

Installation Hotline: 866.394.6776

inpro®