

300-A09-025

JOINT WIDTH		MOVEMENT ±			
		HORIZONTAL		VERTICAL	
US	mm	US	mm	US	mm
1"	25	1/4"	6	3/4"	19

FINISH: CLEAR ANODIZED

PROJECT:

CUSTOMER:

LOCATION:

APPLICATION-
GLIDE PLATE
WALL/CORNER-WALL/CEILING CONDITION

DATE: 5-24-05

SCALE: 1:2

DOC: CADJM.018/R3

inpro.
For More Information Visit: Inprocorp.com

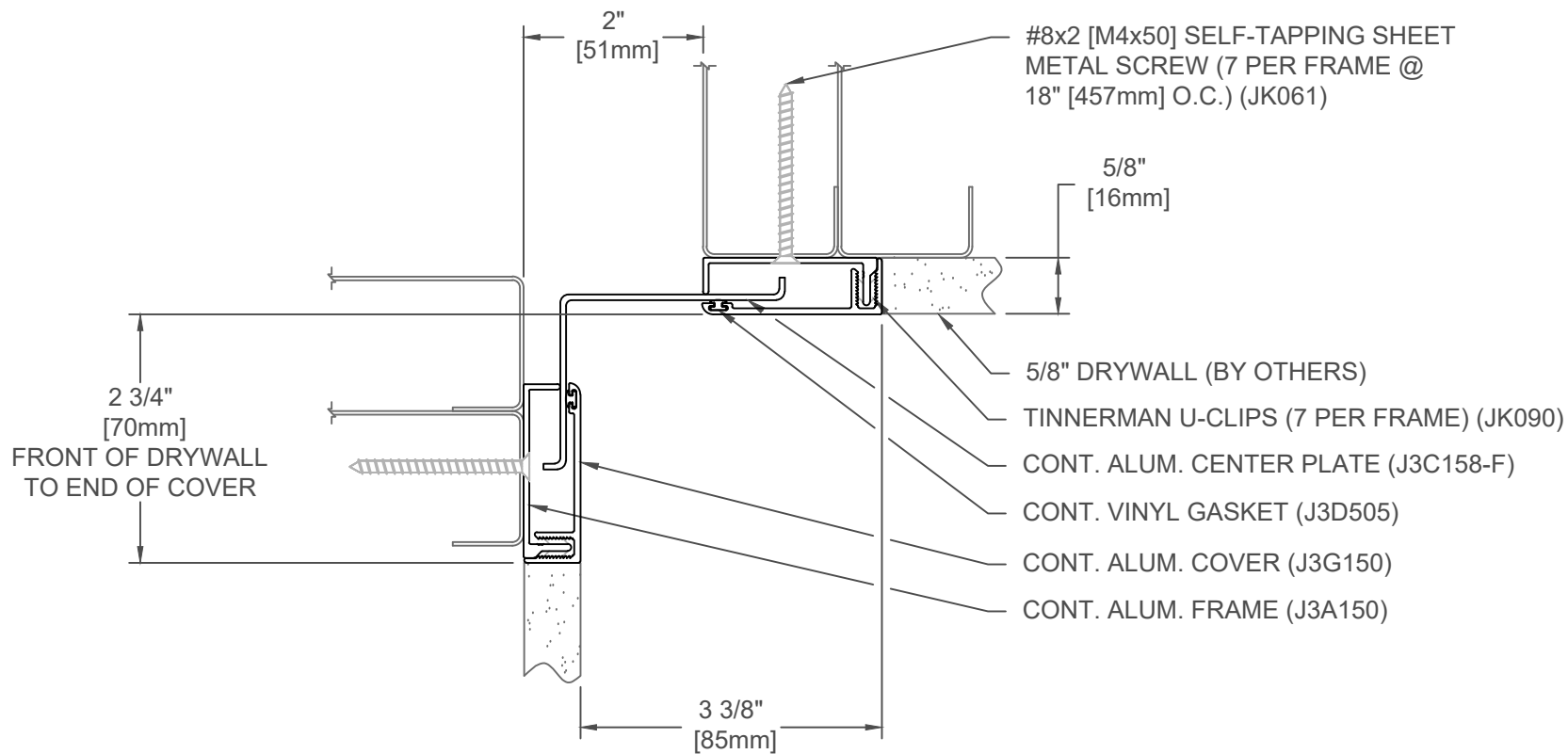

300-A09-050

JOINT WIDTH		MOVEMENT ±			
		HORIZONTAL		VERTICAL	
US	mm	US	mm	US	mm
2"	51	1/2"	13	3/4"	19

FINISH: CLEAR ANODIZED

PROJECT:

CUSTOMER:

LOCATION:

APPLICATION-
GLIDE PLATE
WALL/CORNER, WALL/CEILING
CONDITION

DATE: 5-24-05

SCALE: 1:2

DOC: CADJM.018/R3

inpro.

For More Information Visit: Inprocorp.com

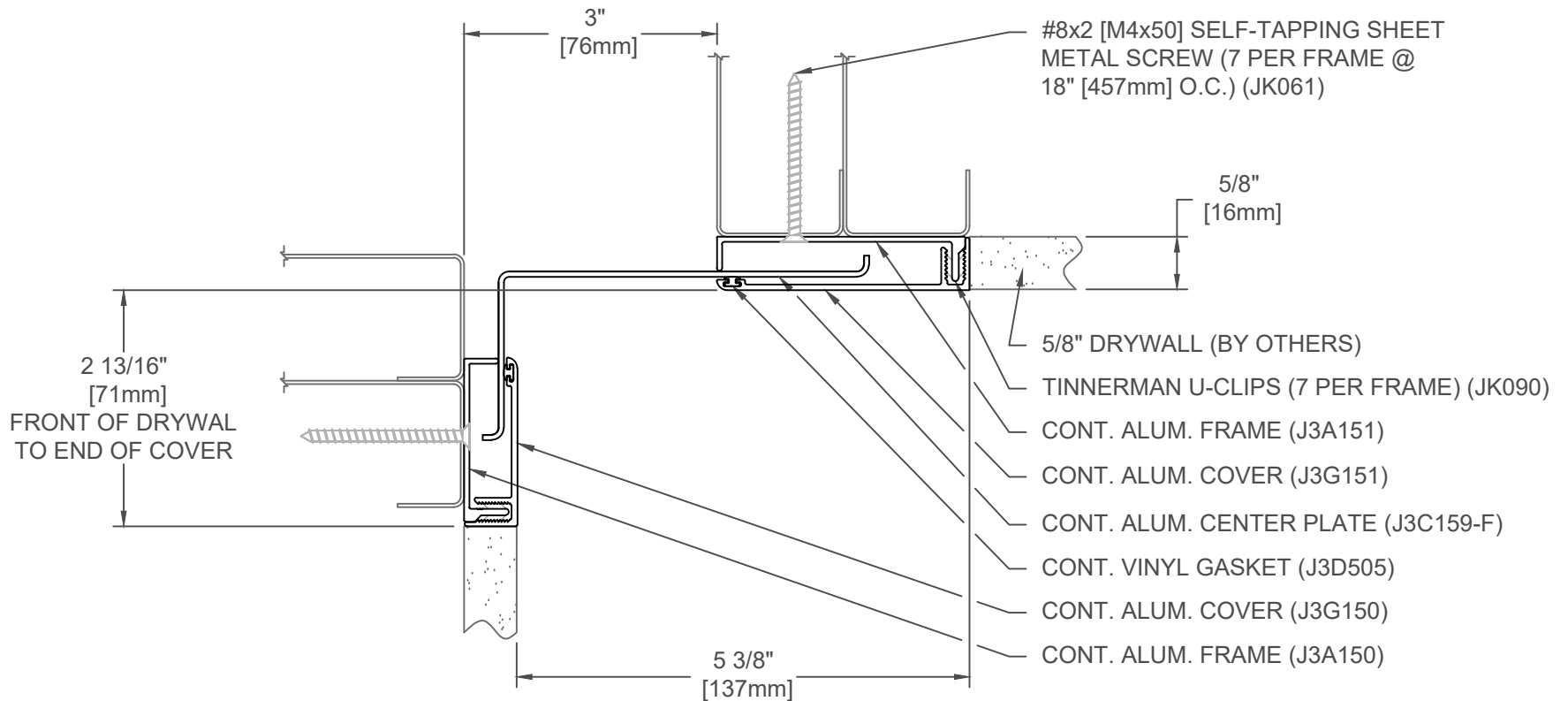

300-A09-075

JOINT WIDTH		MOVEMENT ±			
		HORIZONTAL		VERTICAL	
US	mm	US	mm	US	mm
3"	76	3/4"	19	7/8"	22

FINISH: CLEAR ANODIZED
PROJECT:
CUSTOMER:
LOCATION:

APPLICATION-
GLIDE PLATE
WALL/CORNER, WALL/CEILING
CONDITION

DATE:	5-24-05
SCALE:	1:2
DOC:	CADJM.018/R3



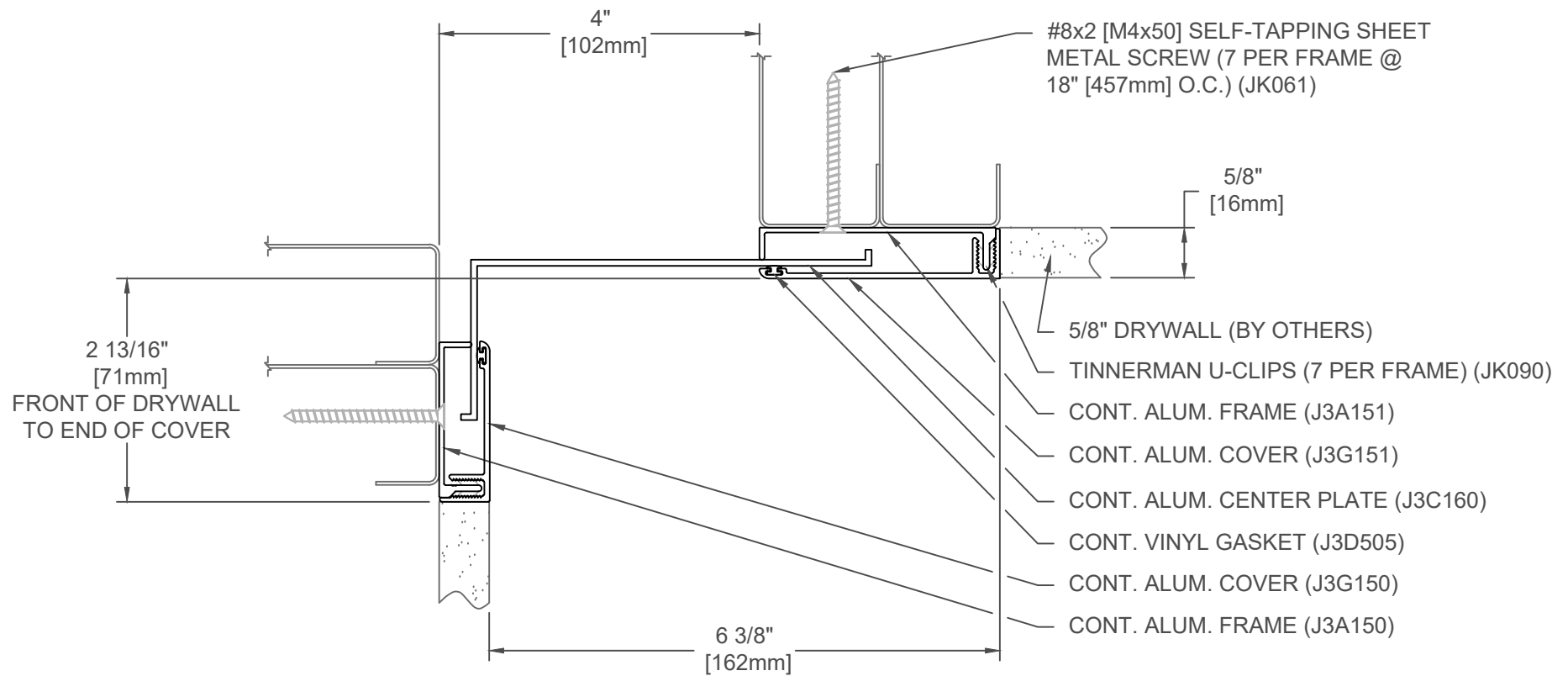

300-A09-100

JOINT WIDTH		MOVEMENT ±			
		HORIZONTAL		VERTICAL	
US	mm	US	mm	US	mm
4"	102	1"	25	1"	25

FINISH: CLEAR ANODIZED
PROJECT:
CUSTOMER:
LOCATION:

APPLICATION-
GLIDE PLATE
WALL/CORNER, WALL/CEILING
CONDITION

DATE:	5-24-05
SCALE:	1:2
DOC:	CADJM.018/R3

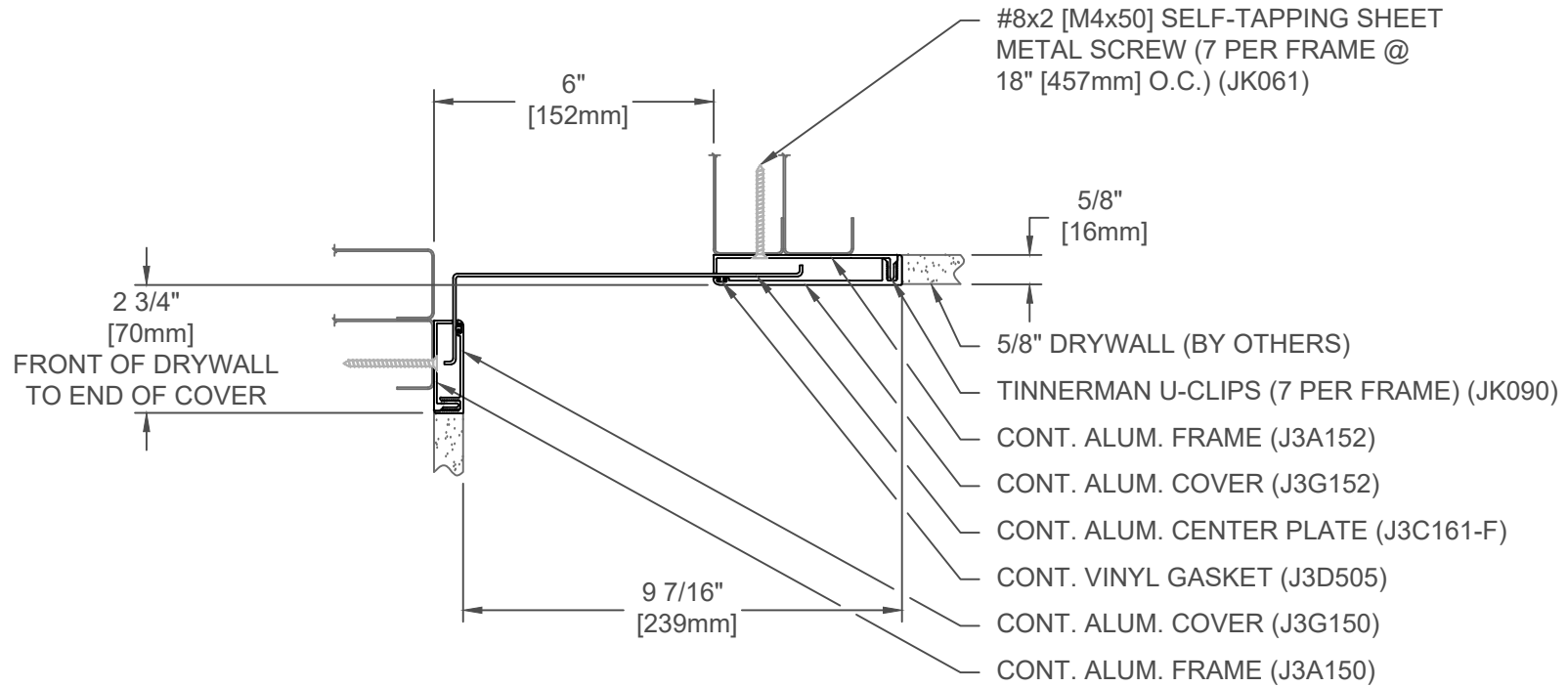

300-A09-150

JOINT WIDTH		MOVEMENT ±			
		HORIZONTAL		VERTICAL	
US	mm	US	mm	US	mm
6"	152	1 1/2"	38	1 1/4"	32

FINISH: CLEAR ANODIZED

PROJECT:

CUSTOMER:

LOCATION:

APPLICATION-
GLIDE PLATE
WALL/CORNER, WALL/CEILING
CONDITION

DATE: 5-24-05

SCALE: 1:4

DOC: CADJM.018/R3

inpro.

For More Information Visit: Inprocorp.com

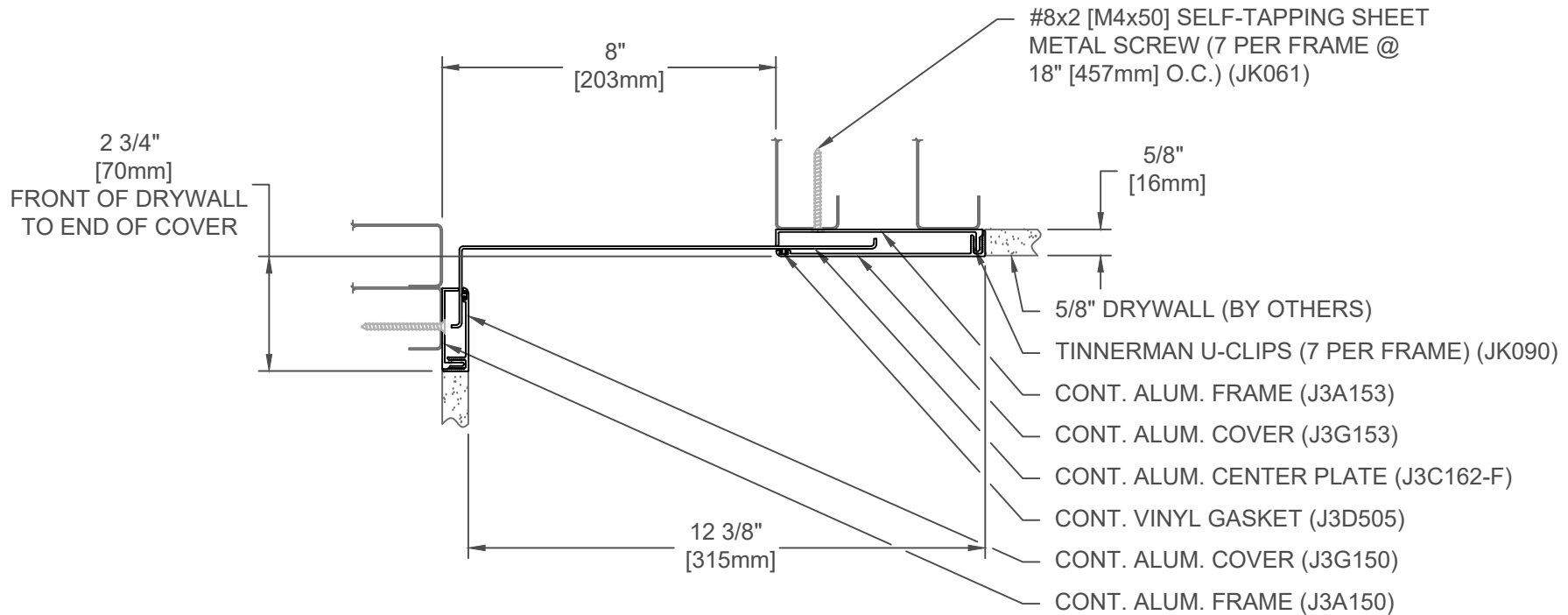

300-A09-200

JOINT WIDTH		MOVEMENT ±			
		HORIZONTAL		VERTICAL	
US	mm	US	mm	US	mm
8"	203	2"	51	1 1/4"	32

FINISH: CLEAR ANODIZED

PROJECT:

CUSTOMER:

LOCATION:

APPLICATION-
GLIDE PLATE
WALL/CORNER, WALL/CEILING
CONDITION

DATE: 5-24-05

SCALE: 1:4

DOC: CADJM.018/R3

inpro.

For More Information Visit: Inprocorp.com

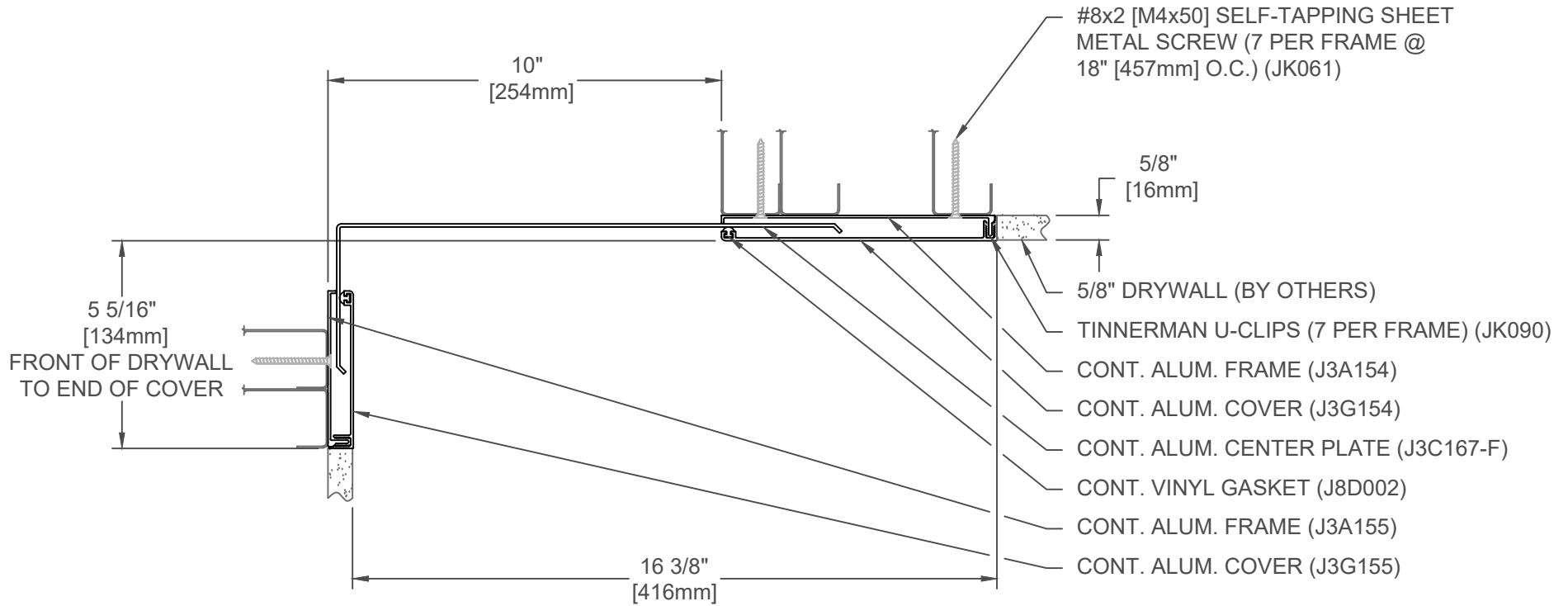

300-A09-250

JOINT WIDTH		MOVEMENT ±			
		HORIZONTAL		VERTICAL	
US	mm	US	mm	US	mm
10"	254	2 1/2"	64	2"	51

FINISH: CLEAR ANODIZED

PROJECT:

CUSTOMER:

LOCATION:

APPLICATION-
GLIDE PLATE
WALL/CORNER, WALL/CEILING
CONDITION

DATE: 7-23-15

SCALE: 1:4

DOC: CADJM.018/R3

inpro.

For More Information Visit: Inprocorp.com

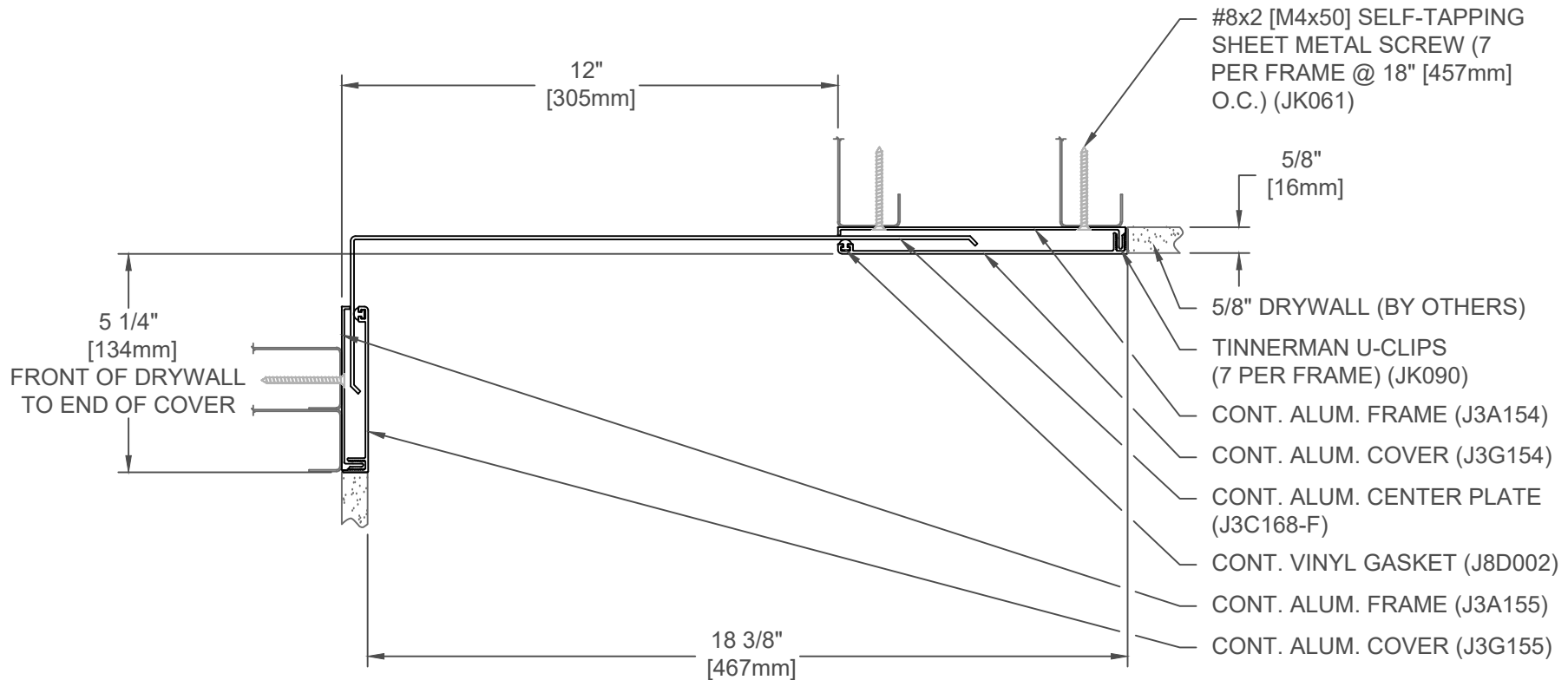

300-A09-300

JOINT WIDTH		MOVEMENT ±			
		HORIZONTAL		VERTICAL	
US	mm	US	mm	US	mm
12"	305	3"	76	2 1/2"	64

FINISH: CLEAR ANODIZED
PROJECT:
CUSTOMER:
LOCATION:

APPLICATION-
GLIDE PLATE
WALL/CORNER, WALL/CEILING
CONDITION

DATE:	7-23-15
SCALE:	1:4
DOC:	CADJM.018/R3

inpro.
For More Information Visit: Inprocorp.com