

F1~F14	FACE MILLING CUTTER / END MILLS CUTTING HOLDER / CUTTING BLOCKS / CHAMFER TOOL / POWER SUPER DRILL / BORING BAR	F29	FINISHING END MILLS
F15~F18	TOOL HOLDER FOR LATHE	F35	SOLID CARBIDE NC / CNC SPOT DRINS
F19~F20	BORING BAR	F36~F37	TWIST DRILLS
F21	TECHNICAL DATA	F38~F40	HIGH PERFORMANCE DRILLS
F22	INSERT FOR FACE MILL CUTTER	F41~F45	COMBINED DRILL AND COUNTERSINK MACHINE REAMERS LONG LENGTH HAND REAMERS-HSS ADJUSTABLE REAMERS OUTSIDE RADIUS SHAPR END MILLS
F27~F28	SOLID CARBIDE END MILLS	F43	COUNTERBORE END MILLS
F33~F34	SOLID CARBIDE BALL NOSE END MILLS / END MILLS	F44	METAL SLITTING SAWS H.S.S. END MILLS
F30	SOLID CARBIDE END MILLS	F45	H.S.S. DRILL
F25	SOLID CARBIDE NC / CNC SPOT DRILLS	F46~F47	TAP SERIES / MAGNITIC TAPPER
F31~F32	FINISHING END MILLS ROUGHING END MILLS		
F28~F29	MACHINE REAMERS IN STEPS OF 0.5MM MACHINE REAMERS CARBIDE TIPPED		
F23~F24	UNIVERSAL END MILLS		
F25	FINISHING END MILLS		
F26	BALL NOSE END MILLS / END MILLS FOR ALUMINIUM		



Face Milling Cutter 45°



45°

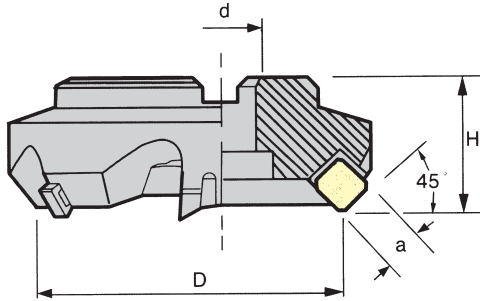

※ All inserts are floating price.
Contact us before ordering from F1~F49

ORDER NO.	D	d \varnothing	INCH METRIC	H	BLADE	WEIGHT(kg)	CODE NO.
SE545-3	80	25.4	27	50	5	2.1	6001-001I
		27					6001-001M
SE545-4	100	31.75	32	55	5	3.5	6001-002I
		32					6001-002M
SE545-5	125	38.1	40	60	6	5.1	6001-003I
		40					6001-003M
SE545-6	160	50.8	40	60	8	7.1	6001-004I
		40					6001-004M
SE545-8	200	47.625	60	60	10	10.4	6001-005I
		60					6001-005M
SE545-10	250	47.625	60	60	12	16.8	6001-006I
		60					6001-006M
SE545-12	300	47.625	60	60	14	27	6001-007I
		60					6001-007M
SE445-3	80	25.4	27	50	5	2.1	6001-020I
		27					6001-020M
SE445-4	100	31.75	32	55	5	3.2	6001-021I
		32					6001-021M
SE445-5	125	38.1	40	60	6	4.7	6001-022I
		40					6001-022M
SE445-6	160	50.8	40	60	8	7.3	6001-023I
		40					6001-023M
SE445-8	200	47.625	60	60	10	9.6	6001-024I
		60					6001-024M
SE445-10	250	47.625	60	60	12	16.7	6001-025I
		60					6001-025M
SE445-12	300	47.625	60	60	14	25.8	6001-026I
		60					6001-026M

PARTS

SCR-CL5/16	CL-S	SCR-ST-S4	ST-S	WRN-M4T

INSERT

545 HEAVY DUTY		445 LIGHT DUTY	
SEKN-1504		SEKN-1203	

Face Milling Cutter 65°

65°

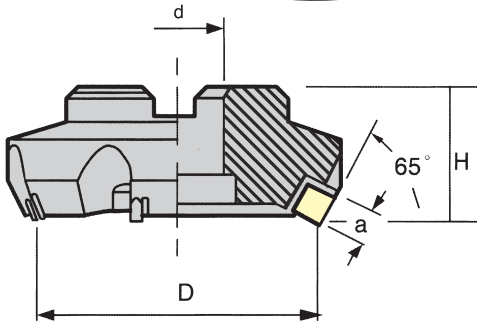

ORDER NO.	D	d \varnothing	INCH METRIC	H	BLADE	WEIGHT(kg)	CODE NO.
SP535-3	80	25.4	27	50	5	2.1	6001-040I
		27					6001-040M
SP535-4	100	31.75	32	55	5	3.3	6001-041I
		32					6001-041M
SP535-5	125	38.1	40	60	6	5.6	6001-042I
		40					6001-042M
SP535-6	160	50.8	40	60	8	7.4	6001-043I
		40					6001-043M
SP535-8	200	47.625	60	60	10	10.2	6001-044I
		60					6001-044M
SP535-10	250	47.625	60	60	12	17.5	6001-045I
		60					6001-045M
SP535-12	300	47.625	60	60	14	26.8	6001-046I
		60					6001-046M
SP435-3	80	25.4	27	50	5	2.1	6001-070I
		27					6001-070M
SP435-4	100	31.75	32	55	5	3.3	6001-071I
		32					6001-071M
SP435-5	125	38.1	40	60	6	5.5	6001-072I
		40					6001-072M
SP435-6	160	50.8	40	60	8	7.8	6001-073I
		40					6001-073M
SP435-8	200	47.625	60	60	10	10.1	6001-074I
		60					6001-074M
SP435-10	250	47.625	60	60	12	17.5	6001-075I
		60					6001-075M
SP435-12	300	47.625	60	60	14	26.8	6001-076I
		60					6001-076M

PARTS

SCR-CL5/16	CL-S	SCR-ST-S4	ST-S	WRN-M4T

INSERT

535 HEAVY DUTY		435 LIGHT DUTY	
SPKN-1504		SPKN-1204	



Face Milling Cutter 75°



75°

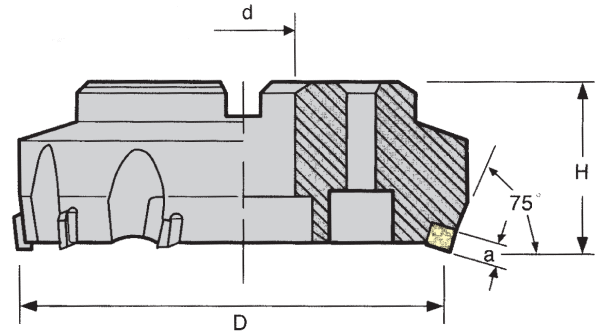

ORDER NO.	D	dØ	INCH METRIC	H	BLADE	WEIGHT(kg)	CODE NO.
FP-3	80	25.4	27	50	5	2	6001-090I
							6001-090M
FP-4	100	31.75	32	55	6	3.1	6001-091I
							6001-091M
FP-5	125	38.1	40	60	8	5.3	6001-092I
							6001-092M
FP-6	160	50.8	40	60	10	6.5	6001-093I
							6001-093M
FP-8	200	47.625	60	60	12	9.6	6001-094I
							6001-094M
							6001-094M
FP-10	250	47.625	60	60	16	17.1	6001-095I
							6001-095M
FP-12	300	47.625	60	60	20	29.3	6001-096I
							6001-096M

INSERT	PARTS				
SPUN-120308 SPKN-120 3 1203EDR					
		SCR-CL5/16	CL-S	SCR-ST-S4	ST-S



Face Milling Cutter 90°

90°

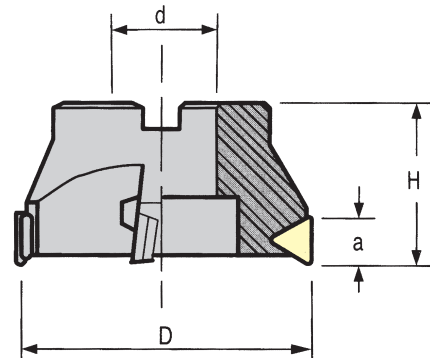

※All inserts are floating price.
Contact us before ordering from F1~F49

ORDER NO.	D	dØ	INCH METRIC	H	a	BLADE	WEIGHT(kg)	INSERT					CODE NO.																														
TP-63	63	25.4	27	50	22	3	0.7	TPMN 2204					6001-110I																														
													6001-110M																														
TP-80	80	25.4	27	50	22	4	1.1						TPKN 2204PPR					6001-111I																									
																		6001-111M																									
TP-100	100	31.75	32	55	22	5	1.9											TPMN 2204					6001-112I																				
																							6001-112M																				
TP-125	125	38.1	40	60	22	6	3																TPKN 2204PPR					6001-113I															
																												6001-113M															
TP-160	160	50.8	40	60	22	7	4.9																					TPMN 2204					6001-114I										
																																	6001-114M										
TP-200	200	47.625	60	60	22	8	8.1																										TPKN 2204PPR					6001-115I					
																																						6001-115M					
TP-250	250	47.625	60	60	22	9	15.9																															TPMN 2204					6001-116I
																																											6001-116M
TP-300	300	47.625	60	60	22	10	28	TPKN 2204PPR																																			6001-117I
																																											6001-117M



MILLING CUTTER

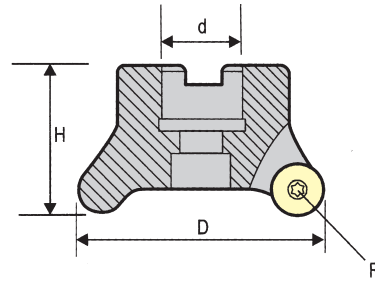

Round Insert Milling Cutter





※All inserts are floating price.
Contact us before ordering from F1~F49

ORDER NO.	D	d \varnothing inch metrics	H	BLADE	R	HITACHI INSERT	SCREW FOR INSERT 	SCREW FOR CLAMP	CLAMP 	CODE NO.	
RM-5R50	50	- 22	45	4	5	RDMT10T3	SCR-CRS4	SCR-DM3.5	CL-5R	T15	6001-130M
RM-5R63	63	25.4 22	50	5	5	RDMT10T3	SCR-CRS4		CL-5R	T15	6001-131I 6001-131M
RM-8R50	50	- 22	45	3	8	RDMT1604	SCR-CRS5	SCR-W 1/4S		T20	6001-133M
RM-8R63	63	25.4 22	50	3/4	8	RDMT1604	SCR-CRS5			T20	6001-134I 6001-134M

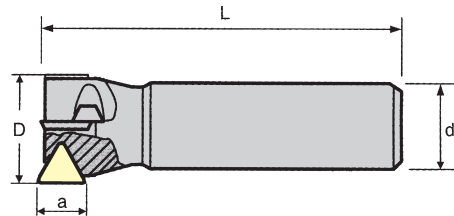

Shoulder End Mills



ORDER NO.	D	d	L	BLADE	INSERT			WEIGHT (kg)	CODE NO.
SAE-20	20	20	110	2	TPMN110308	SCR-W3/16	WRN-M3L	0.4	6001-150
SAE-25	25	20	110	2	TPMN110308	SCR-W3/16	WRN-M3L	0.3	6001-151
SAE-30	30	20	130	2	TPMN160308	SCR-W1/4	WRN-M4L	0.5	6001-152
SAE-35	35	20	130	2	TPMN160308	SCR-W1/4	WRN-M4L	0.4	6001-153
SAE-40	40	20	130	3	TPMN160308	SCR-W1/4	WRN-M4L	0.5	6001-154
SAE-45	45	20	130	3	TPMN160308	SCR-W1/4	WRN-M4L	0.6	6001-155
SAE-50	50	20	130	3	TPMN160308	SCR-W1/4	WRN-M4L	0.7	6001-156
SAE-63	63	32	150	4	TPMN160308	SCR-W1/4	WRN-M4L	1.5	6001-157

High-Speed Face Milling Cutter 45°

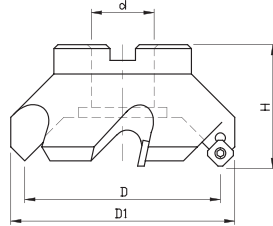

※ All inserts are floating price.
Contact us before ordering from F1~F49

- Material : SNCM439
- Hardness : HRC42
- Accuracy : 0.03 mm

ORDER NO.	D	D1	dØ	INCH METRIC	H	BLADE	WEIGHT(kg)	INSERT	SCREW	WRENCH	CODE NO.
HCB-50	50	60	-	22	45	4	0.53	SEKT1204	SCR-SE5	T20	6001-170M
HCB-63	63	75	25.4	27	50	5	0.83	SEKT1204	SCR-SE5	T20	6001-171I
			27								6001-171M
HCB-80	80	96	25.4	27	55	6	1.24	SEKT1204	SCR-SE5	T20	6001-172I
			27								6001-172M
HCB-100	100	116	31.75	32	55	6	1.83	SEKT1204	SCR-SE5	T20	6001-173I
			32								6001-173M
HCB-125	125	141	38.1	40	60	8	3.09	SEKT1204	SCR-SE5	T20	6001-174I
			40								6001-174M
HCB-150	150	158	50.8	40	60	10	4.06	SEKT1204	SCR-SE5	T20	6001-175I
			40								6001-175M
HCB-200	200	212	47.625	60	60	12	7.68	SEKT1204	SCR-SE5	T20	6001-176I
			60								6001-176M

High-Speed Face Milling Cutter 45°

ZINC COATED

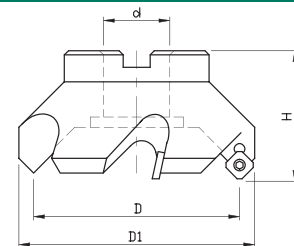

- Material : SNCM439
- Hardness : HRC42
- Accuracy : 0.03 mm

ORDER NO.	D	D1	dØ	INCH METRIC	H	BLADE	WEIGHT(kg)	INCH METRIC	INSERT	SCREW	WRENCH	CODE NO.
HCN-63	63	175	25.4	22	50	5	0.87		SEMT13T3	SCR-SE4	T15	6001-190I
			22									6001-190M
HCN-80	80	96	25.4	27	55	6	1.24		SEMT13T3	SCR-SE4	T15	6001-191I
			27									6001-191M
HCN-100	100	116	31.75	32	55	6	1.83		SEMT13T3	SCR-SE4	T15	6001-192I
			32									6001-192M
HCN-125	125	141	38.1	40	60	8			SEMT13T3	SCR-SE4	T15	6001-193I
			40									6001-193M
HCN-150	160	158	50.8	40	60	10	3.82		SEMT13T3	SCR-SE4	T15	6001-194I
			40									6001-194M
HCN-200	200	212	47.625	60	60	12	7.88		SEMT13T3	SCR-SE4	T15	6001-195I
			60									6001-195M

High-Speed Face Milling Cutter

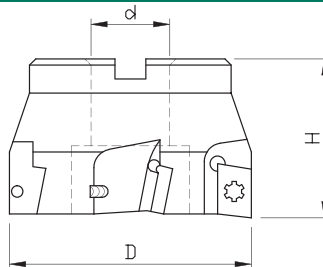

- Material : SNCM439
- Hardness : HRC42
- Accuracy : 0.03 mm

ORDER NO.	D	dØ	INCH METRIC	H	BLADE	WEIGHT(kg)	INSERT	SCREW	WRENCH	CODE NO.
FMC-50	50	25.4	22	40	4	0.34	APMT1604	SCR-CAP4	T15	6001-200I
		22								6001-200M
FMC-63	63	25.4	22	40	5	0.57	APMT1604	SCR-CAP4	T15	6001-201I
		22								6001-201M
FMC-80	80	25.4	27	50	6	1.15	APMT1604	SCR-CAP4	T15	6001-202I
		27								6001-202M
FMC-100	100	31.75	32	50	7	1.83	APMT1604	SCR-CAP4	T15	6001-203I
		32								6001-203M
FMC-125	125	38.1	40	50	8	2.99	APMT1604	SCR-CAP4	T15	6001-204I
		40								6001-204M
FMC-160	160	38.1	40	50	10	5.07	APMT1604	SCR-CAP4	T15	6001-205I
		40								6001-205M

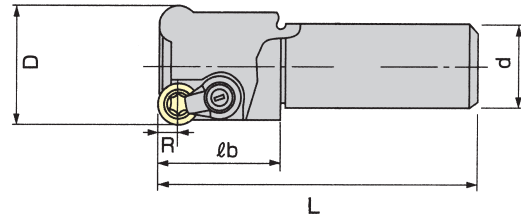

※All inserts are floating price.
Contact us before ordering from F1~F49

ORDER NO.	BLADE	D	L	d	lb	R	HITACHI INSERT	CLAMP	SCREW FOR CLAMP	SCREW FOR INSERT	CODE NO.	
C20-4R20-150	2	20	150	20	50	4	RDMT0802	-	SCR-DM3.5	SCR-CRS3	T8	6002-001
C25-5R25-150	2	25	150	25	60	5	RDMT10T3	CL-5R		SCR-CRS4	T15	6002-002
C25-5R25-200	2	25	200	25	120	5	RDMT10T3	CL-5R		SCR-CRS4	T15	6002-003
C25-5R30-150	2	30	150	25	50	5	RDMT10T3	CL-5R		SCR-CRS4	T15	6002-004
C25-5R30-200	2	30	200	25	50	5	RDMT10T3	CL-5R		SCR-CRS4	T15	6002-005
C32-5R32-150	3	32	150	32	70	5	RDMT10T3	CL-5R		SCR-CRS4	T15	6002-006
C32-5R32-200	3	32	200	32	120	5	RDMT10T3	CL-5R		SCR-CRS4	T15	6002-007
C32-5R35X150	3	35	150	32	50	5	RDMT10T3	CL-5R		SCR-CRS4	T15	6002-008
C32-5R35X200	3	35	200	32	50	5	RDMT10T3	CL-5R		SCR-CRS4	T15	6002-009
C32-5R40X150	3	40	150	32	50	5	RDMT10T3	CL-5R		SCR-CRS4	T15	6002-010
C32-5R40X200	3	40	200	32	50	5	RDMT10T3	CL-5R		SCR-CRS4	T15	6002-011

Drilling & Milling Cutter

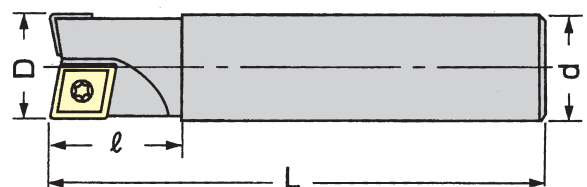

ORDER NO.	BLADE	D	L	d	l						CODE NO.
C16-DM16-120	2	16	120	16	30	CCMT060204	CPMT080204Z	SCR-CJU2.5	-	T8	6002-030
C16-DM16-175	2	16	175	16	40	CCMT060204	CPMT080204Z	SCR-CJU2.5	-	T8	6002-031
C20-DM20-130	2	20	130	20	30	CCMT060204	CPMT090204Z	SCR-CJU2.5	SCR-CJU3.5	T8.T15	6002-032
C20-DM20-185	2	20	185	20	50	CCMT060204	CPMT090204Z	SCR-CJU2.5	SCR-CJU3.5	T8.T15	6002-033
C25-DM25-130	2	25	130	25	40	CPMT090308	CPMT120308Z	SCR-CJU4	-	T15	6002-034
C25-DM25-220	2	25	220	25	70	CPMT090308	CPMT120308Z	SCR-CJU4	-	T15	6002-035
C32-DM32-170	2	32	170	32	50	CPMT120408	CPMT160408Z	SCR-CJU5	-	T20	6002-036
C32-DM32-250	2	32	250	32	80	CPMT120408	CPMT160408Z	SCR-CJU5	-	T20	6002-037



High Speed Shoulder Mills



C16-SS16-120H

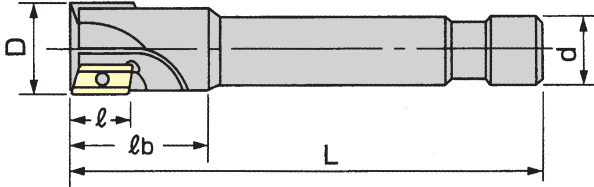

C25-SS25-150M



※All inserts are floating price.
Contact us before ordering from F1~F49

ORDER NO.	BLADE	D	L	d	l	lb	HITACHI / MITSUBISHI				CODE NO.
C16-SS16-120H	1	16	120	16	12	30	APET120204 HITACHI		SCR-CEX3.5	T15	6002-060
C20-SS20-120H	2	20	120	20	12	30	APET120204 HITACHI		SCR-CEX3.5	T15	6002-062
C20-SS20-200H	2	20	200	20	15	30	APET120204 HITACHI		SCR-CEX4	T15	6002-063
C25-SS25-130H	2	25	130	25	15	35	ADET160304 HITACHI		SCR-CEX4	T15	6002-064
C25-SS25-200H	2	25	200	25	15	35	ADET160304 HITACHI		SCR-CEX4	T15	6002-065
C32-SS32-150H	3	32	150	32	15	45	ADET160304 HITACHI		SCR-CEX4	T15	6002-066
C32-SS32-200H	3	32	200	32	15	45	ADET160304 HITACHI		SCR-CEX4	T15	6002-067
C25-SS25-150M	2	25	150	25	14	35	APMT1604PDER MITSUBISHI		SCR-CAP4	T15	6002-069
C25-SS30-150M	2	30	150	25	14	45	APMT1604PDER MITSUBISHI		SCR-CAP4	T15	6002-070
C32-SS32-150M	3	32	150	32	14	45	APMT1604PDER MITSUBISHI		SCR-CAP4	T15	6002-080
C32-SS32-250M	3	32	250	32	-	60	APMT1604PDER MITSUBISHI		SCR-CAP4	T15	6002-081
C32-SS35-150M	3	35	150	32	14	45	APMT1604PDER MITSUBISHI		SCR-CAP4	T15	6002-082
C32-SS40-150M	4	40	150	32	14	45	APMT1604PDER MITSUBISHI		SCR-CAP4	T15	6002-083

SHOULDER MILLS



Ball End Mills

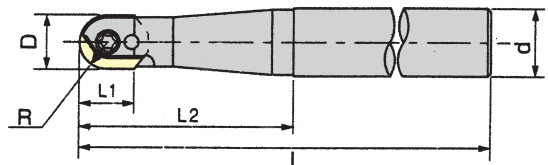

ORDER NO.	R	D	d	L	L ₁	L ₂	INSERT	SCREW	SCREW	WRENCH	WEIGHT (kg)	CODE NO.
C20-AR8-160	8	16	20	160	13	65	ZPFW160	SCR-AR8	SCR-CBP3.5	T15	0.5	6002-130
C25-AR10-250	10	20	25	250	17	80	ZPFW200	SCR-AR10	SCR-CBP5	T20		6002-131A
C32-AR12.5-200	12.5	25	32	200	22	90	ZPFW250	SCR-AR12.5	SCR-CBP5	T20		6002-132



High-Speed Rough End Mills

**VERTEX®**

Mitsubishi inserts recommended

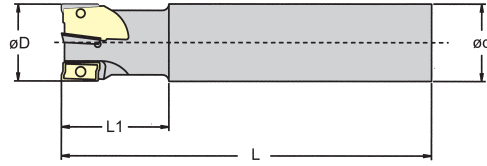

※All inserts are floating price.

Contact us before ordering from F1~F49

ORDER NO.	BLADE	D	d	L	L1	INSERT	SCREW	WRENCH	CODE NO.
VAPX-1616	2	16	16	120	24	MITSUBISHI AOMT 123608	SCR- APX2.5	T8	6002-150
VAPX-1716	2	17	16	150	24				6002-151
VAPX-2020	3	20	20	150	29				6002-152
VAPX-2120	3	21	20	150	29				6002-153
VAPX-2525	4	25	25	150	34				6002-154
VAPX-2625	4	26	25	200	34				6002-155

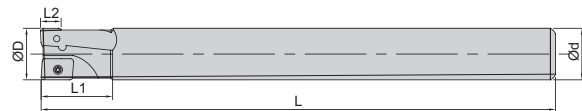

High-Speed Rough End Mills

NEW

ORDER NO.	BLADE	D	d	L	L1	L2			WRENCH	WEIGHT (KG)	CODE NO.
VHRE-21010	2	10	10	100	28	5	XOMX-0602	SCR-AXO1.8	T6	0.07	6002-171
VHRE-21110	2	11	10	100	28	5				0.07	6002-172
VHRE-21212	2	12	12	120	28	5				0.11	6002-173
VHRE-21312	2	13	12	120	33	5				0.11	6002-174
VHRE-31412	3	14	12	120	25	5				0.11	6002-175
VHRE-22085	2	20	20	85	26	11	XOMX-1204	SCR-AXO3.5	T10	0.34	6002-181
VHRE-22015	2	20	20	150	26	11				0.36	6002-182
VHRE-22020	2	20	20	200	26	11				0.49	6002-183
VHRE-22215	2	22	20	150	26	11				0.37	6002-184
VHRE-32595	3	25	25	95	32	11				0.34	6002-185
VHRE-32515	3	25	25	150	32	11				0.54	6002-186
VHRE-32520	3	25	25	200	32	11	0.75	6002-187			



CRT Round Insert End Mills



Mitsubishi inserts recommended

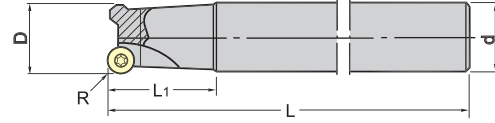

※All inserts are floating price.
Contact us before ordering from F1~F49

ORDER NO.	D	d	R	L	BLADE	INSERT			CLAMP	WEIGHT (kg)	CODE NO.
CRT-6R32X150	32	32	6	150	3	RPMT1204MO	SCR-M3.5	SCR-CRT4	CL-CRT	0.9	6003-051
CRT-6R32X200	32	32	6	200	3	RPMT1204MO	SCR-M3.5	SCR-CRT4	CL-CRT	1.3	6003-052
CRT-6R35X150	35	32	6	150	3	RPMT1204MO	SCR-M3.5	SCR-CRT4	CL-CRT	1.1	6003-053
CRT-6R35X200	35	32	6	200	3	RPMT1204MO	SCR-M3.5	SCR-CRT4	CL-CRT	1.3	6003-054



Face End Mills

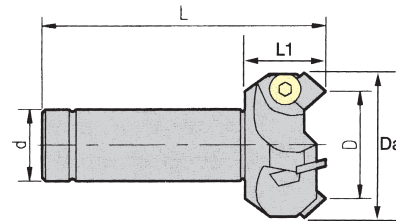

ORDER NO.	D	Da	d	L	L ₁	BLADE	INSERT			WEIGHT (kg)	CODE NO.
C-32-SE445-50	50	62	32	150	45	3	SEKN1203	SCR-W1/4L	WRN-M4T	1.25	6003-060
C-32-SE445-63	63	74	32	150	45	4	SEKN1203	SCR-W1/4L	WRN-M4T	1.3	6003-061



Shoulder Face Milling Cutter

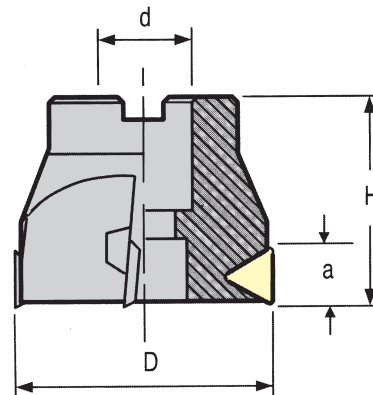

ORDER NO.	D	d METRIC	H	a	BLADE	INSERT			CODE NO.
TPS-50	50	22	50	16	3	TPMN1603	SCR-W1/4	WRN-M4L	6003-065
TPS-63	63	22	50	16	4	TPMN1603	SCR-W1/4	WRN-M4L	6003-066

INSERT END MILLS

45° Chamfering End Mills



※All inserts are floating price.
Contact us before ordering from F1~F49



ORDER NO.	Cutter Dia.	Shank Dia.	Length	Capacity	Screw	Wrench	INSERT	WEIGHT (kg)	CODE NO.
TC12	25 ϕ	12 ϕ	110	8 ϕ ~25 ϕ	M4	T15	TCMT16T304	0.2	6004-002
TC40	40 ϕ	12 ϕ	100	20 ϕ ~36 ϕ	M4	T15	TCMT16T304	0.34	6004-003

45° Chamfering End Mills

ISO CODE

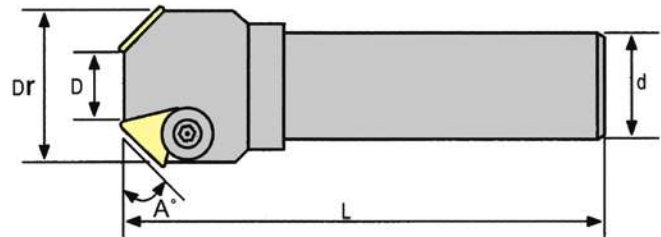

ORDER NO.	A°	D	Dr	d	L	BLADE	INSERT	SCREW	WRENCH	CODE NO.
VCE-4521	45	5	21	16	120	1	TPUN1603	SCR-W1/4	WRN-M4L	6004-005
VCE-4531	45	10	31	20	120	2				6004-006
VCE-4550	45	20	50	25	130	3	TPUN2204	SCR-W5/16	WRN-M5L	6004-007
VCE-4532	45	6	32	32	150	1				6004-008
VCE-4563	45	35	63	25	150	3				6004-009

T-Slot End Mills

ISO CODE

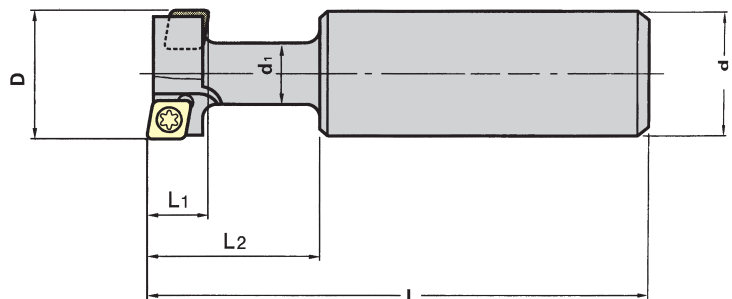

ORDER NO.	D	L1	d	d1	L2	L	BLADE	INSERT	SCREW	WRENCH	WEIGHT	CODE NO.
VTE-2411	24	11	20	12	29	90	4	CCMT-060204	SCR-TS2.5	T8	0.19	6004-015
VTE-3114	31	14	25	15	42	110	4	CPMT-080204Z			0.36	6004-016
VTE-3918	39	18	32	19	49	120	4	CPMT-090308	SCR-TS4	T15	0.61	6004-017
VTE-4922	49	22	32	25	60	140	4	CPMT-120408	SCR-TS5	T20	0.82	6004-018

Chamfer Tool

High Speed steel $\theta 90^\circ$
H.S.S. 

NEW

※ All inserts are floating price.
Contact us before ordering from F1~F49

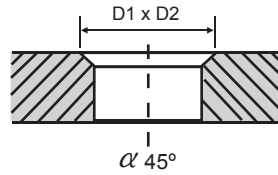
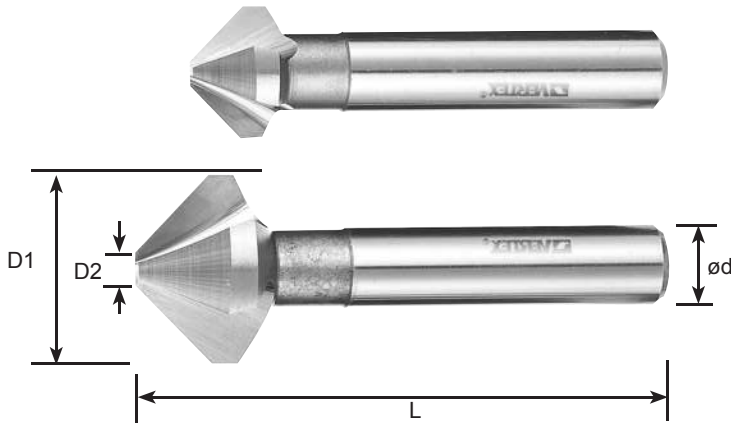

- Counter sink hole
- Uncoated
- Flutes
- Cutting Angle: 90°
- Round SHANK
- Material: H.S.S.

Unit : mm

ORDER NO.	D1	D2	L mm	SHANK Ød	CODE NO.
CTH-51	5.0	1.5	40	4	6004-041
CTH-61	6.3	1.5	45	5	6004-042
CTH-82	8.3	2	50	6	6004-043
CTH-102	10.4	2.5	50	6	6004-044
CTH-122	12.4	2.8	56	8	6004-045
CTH-132	13.4	2.9	56	8	6004-046
CTH-163	16.5	3.2	60	10	6004-047
CTH-203	20.5	3.5	63	10	6004-048
CTH-253	25.0	3.8	67	10	6004-049
CTH-314	31.0	4.2	71	12	6004-050

Chamfer Tool 6 Pcs Kits

High speed steel 90°
H.S.S.

NEW

- Counter sink hole
- Uncoated
- Flutes
- Cutting Angle: 90°
- Round SHANK
- Material: H.S.S.

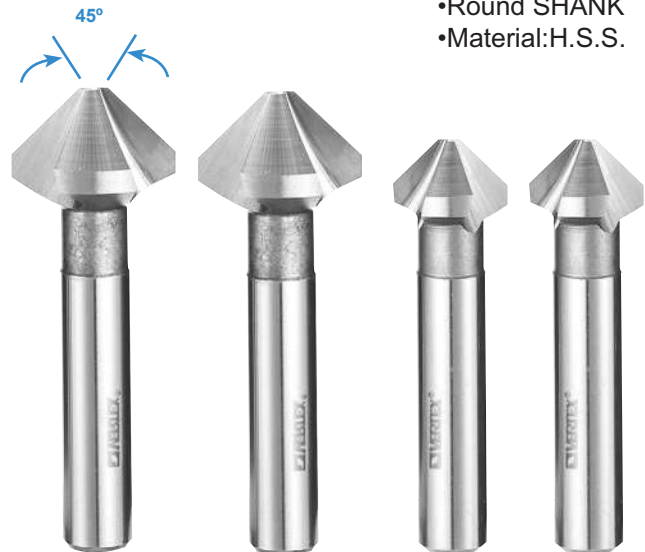

CTH - A INCLUDING θ 6.3, 8.3, 10.4, 12.4, 16.5, 20.5 MM 6 PCS/SET

ORDER NO.	PCS/SET	WEIGHT(KG)	CODE NO.
CTH-A	6 PCS	0.5	6004-055

CHAMFER TOOL



Side Milling Cutter



※All inserts are floating price.
Contact us before ordering from F1~F49

ISO CODE

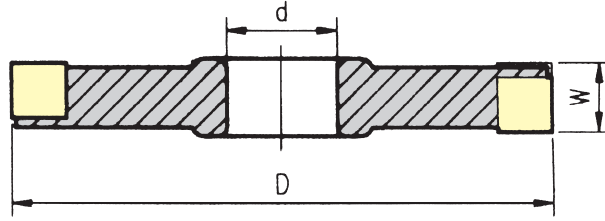

ORDER NO.	D	d	W	BLADE	INSERT	CLAMP	SCREW	WRENCH	CODE NO.
VSM-1016	100	1"	16	10	SPUN 120304	CL-S CL-SL	SCR- CL5/16	WRN-M4T	6004-020
VSM-1216	125	1"	16	14					6004-021
VSM-1516	150	1"	16	16					6004-022
VSM-2016	200	1"	16	20					6004-023



T-Side Milling Cutter

NEW

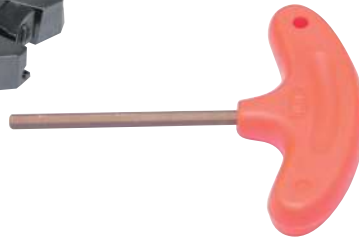

● Inserts : ISO Code

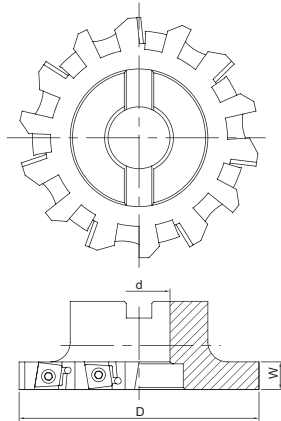

mm

ORDER NO.	BLADE	D	d	W			CLAMP	WRENCH	WEIGHT (kgs)	CODE NO.
VTSC-416	10	100	25.4	16	SPUN-1203	SCR- CL5/16	CL-S CL-SL	WRN- M4T	0.84	6004-161
VTSC-516	14	125	31.75	16					1.64	6004-162
VTSC-520	14	125	31.75	20	SPUN-1504				1.73	6004-163
VTSC-616	16	150	31.75	16	SPUN-1203				2.20	6004-164
VTSC-620	16	150	31.75	20	SPUN-1203				2.48	6004-165
VTSC-820	20	200	31.75	20	SPUN-1504				4.38	6004-166
VTSC-825	20	200	31.75	25		5.23	6004-167			



Shell-Type Rough Milling Cutter

NEW



● Inserts : Walter / Hitachi

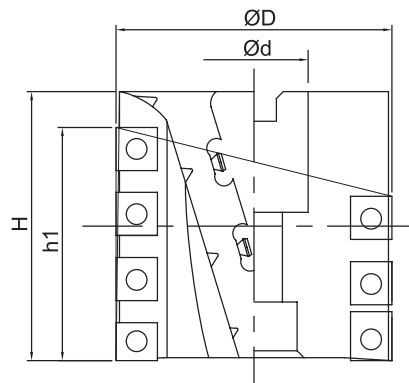

mm

ORDER NO.	FLUTE	D	INCH		H	h1	INSERT		INSERT		WRENCH	WEIGHT (kgs)	CODE NO.	
				METRIC										
VSRC-3	6	80	31.75	32	80	67	LPMT 1504	3	SPMT 1204	18	SCR- RGH5	T20	1.85	6004-171I
VSRC-80			1.85										6004-171M	

Power Super Drill 2L



※All inserts are floating price.
Contact us before ordering from F1~F49

ISO CODE

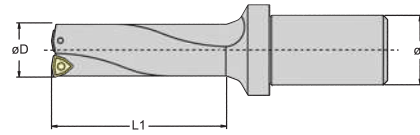

ORDER NO.	D	d	L1	INSERT	SCREW	WRENCH	CODE NO.
VSD-15X2	15	25	30	WCMX030208	SCR-EXD2.5	T8	6004-100
VSD-16X2	16	25	32				6004-101
VSD-17X2	17	25	34				6004-102
VSD-18X2	18	25	36				6004-103
VSD-19X2	19	25	38				6004-104
VSD-20X2	20	25	40				6004-105
VSD-21X2	21	32	42	WCMX040208	SCR-EXD2.5	T8	6004-106
VSD-22X2	22	32	44				6004-107
VSD-23X2	23	32	46				6004-108
VSD-24X2	24	32	48				6004-109
VSD-25X2	25	32	50	WCMX050308	SCR-EXD3	T10	6004-110
VSD-26X2	26	32	52				6004-111
VSD-27X2	27	32	54				6004-112
VSD-28X2	28	32	56				6004-113
VSD-29X2	29	32	58				6004-114
VSD-30X2	30	32	60				6004-115
VSD-31X2	31	32	62	WCMX06T308	SCR-EXD3.5	T15	6004-116
VSD-32X2	32	32	64				6004-117
VSD-33X2	33	32	66				6004-118
VSD-34X2	34	32	68				6004-119
VSD-35X2	35	32	70				6004-120

Power Super Drill 3L

ISO CODE

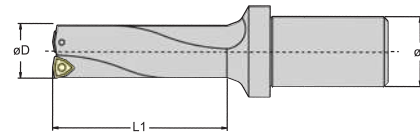

ORDER NO.	D	d	L1	INSERT	SCREW	WRENCH	CODE NO.
VSD-14X3	14	25	42	WCMX030208	SCR-EXD2.5	T8	6004-131
VSD-15X3	15	25	45				6004-132
VSD-16X3	16	25	48				6004-133
VSD-17X3	17	25	51				6004-134
VSD-18X3	18	25	54				6004-135
VSD-19X3	19	25	57				6004-136
VSD-20X3	20	25	60				6004-137
VSD-21X3	21	32	63	WCMX040208	SCR-EXD2.5	T8	6004-138
VSD-22X3	22	32	66				6004-139
VSD-23X3	23	32	69				6004-140
VSD-24X3	24	32	72				6004-141
VSD-25X3	25	32	75	WCMX050308	SCR-EXD3	T10	6004-142
VSD-26X3	26	32	78				6004-143
VSD-27X3	27	32	81				6004-144
VSD-28X3	28	32	84				6004-145
VSD-29X3	29	32	87				6004-146
VSD-30X3	30	32	90				6004-147
VSD-31X3	31	32	93	WCMX06T308	SCR-EXD3.5	T15	6004-148
VSD-32X3	32	32	96				6004-149
VSD-33X3	33	32	99				6004-150
VSD-34X3	34	32	102				6004-151
VSD-35X3	35	32	105				6004-152
VSD-36X3	36	32	108				6004-153
VSD-37X3	37	32	111				6004-154

POWER SUPER DRILL

Vertex Cutting Holder



ISO CODE

※All inserts are floating price.
Contact us before ordering from F1~F49

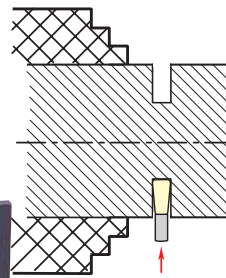

EXAMPLE

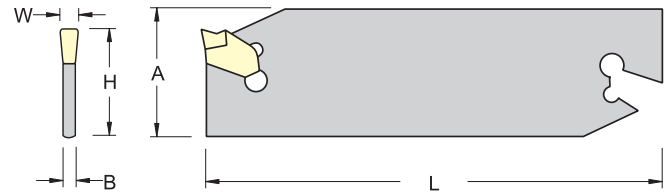

ORDER NO.	H	WORKING MAX. DIA.	W	B	L	A	INSERT	Wrench	WEIGHT(kg)	CODE NO.
CGIH26-3	20	75	3	2.4	100	25.4	NGTN3	SL-1	0.1	6004-030
CGIH32-3	25	100	3	2.4	150	31.3			0.2	6004-031

Vertex Cutting Blocks



EXAMPLE

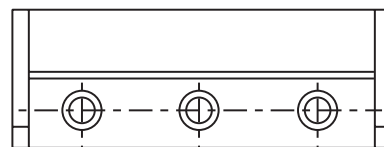

h1: FOR LATHE TOOL POST SIZE

H: IS CUTTING HOLDER HEIGHT FOR CGIH26-3 OR CGIH32-3

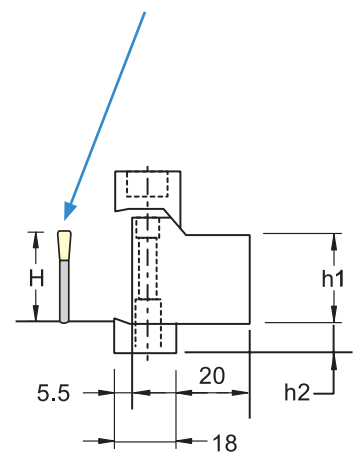

ORDER NO.	H	h1	h2	h3	L	Clamp	Screw	Wrench	Cutting Holders	WEIGHT(kg)	CODE NO.
SBU20-26	20	20	10	45	80	BCS15	BX0622	LH050	CGIH26-3	0.8	6004-060
SBU20-32	20	20	13.5	50	100	BCS20			CGIH32-3	1.1	6004-061
SBU25-32	25	25	8.5	50	110	BCS25			CGIH32-3	1.2	6004-062



Insert Type Boring Bar



Order NO. BBAR-D16

CODE NO.6004-071

※ All inserts are floating price.

Contact us before ordering from F1~F49

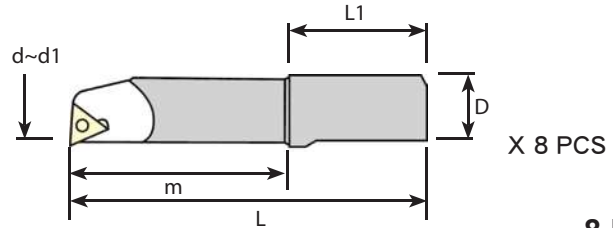

BORING BAR FOR BORING HEAD

8 PCS/SET

BORING BAR	SHANK D.	RANGE d~d1	DEPTH m	L1	SHANK L. L	INSERT	SCREW	WRENCH	WEIGHT (kg)
BRB1608-32	16	8-11	32	32	80	TBGT060102L	TS2001	T6	
BRB1610-40	16	10-13	40	32	80				
BRB1612-53	16	12-15	53	32	85	TPGH090204L	TS2504	T8	
BRB1616-68	16	16-21	68	32	100				
BRB1620-83	16	20-26	83	32	115	TPGH110304L	TS3005	T10	
BRB1625-90	16	25-31	90	32	122				
BRB1630-90	16	30-36	90	32	122				
BRB1640-90	16	40-46	90	32	122				



Insert Type Boring Bar

Order NO. BBAR-D18

CODE NO.6004-072

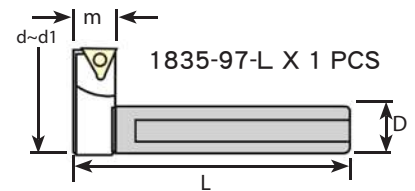
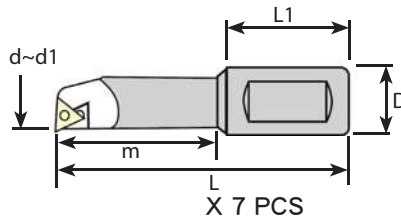

BORING BAR FOR BORING HEAD

8 PCS/SET

BORING BAR	SHANK D.	RANGE d~d1	DEPTH m	L1	SHANK L. L	INSERT	SCREW	WRENCH	WEIGHT (kg)
BRB1808-32	18	8-11	32	32	80	TBGT060102L	TS2001	T6	
BRB1810-40	18	10-13	40	32	80				
BRB1812-53	18	12-17	53	32	85	TPGH090204L	TS2504	T8	
BRB1816-68	18	16-21	68	32	100				
BRB1820-83	18	20-130	83	32	115	TPGH110304L	TS3005	T10	
BRB1825-96	18	25-135	96	32	135				
BRB1830-115	18	30-140	115	32	154				
BRB1835-97-L	18	120-280	14	32	99				



Insert Type Boring Bar

Order NO. BBAR-D20

CODE NO.6004-073

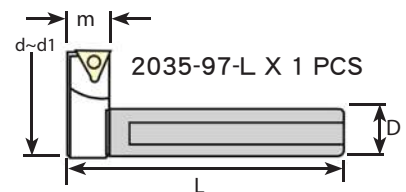
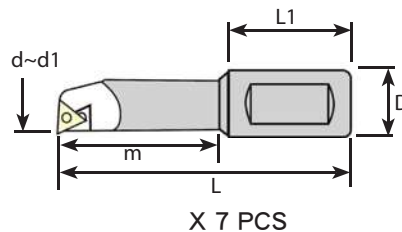

BORING BAR FOR BORING HEAD

8 PCS/SET

BORING BAR	SHANK D.	RANGE d~d1	DEPTH m	L1	SHANK L. L	INSERT	SCREW	WRENCH	WEIGHT (kg)
BRB2008-32	20	8-11	23	32	80	TBGT060102L	TS2001	T6	
BRB2010-40	20	10-13	40	32	80				
BRB2012-53	20	12-17	53	32	85	TPGH090204L	TS2504	T8	
BRB2016-68	20	16-21	68	32	100				
BRB2020-83	20	20-130	83	32	115	TPGH110304L	TS3005	T10	
BRB2025-96	20	25-135	96	32	135				
BRB2030-115	20	30-140	115	32	154				
BRB2035-97-L	20	120-280	14	32	99				

INSERT TYPE BORING BAR

※ All inserts are floating price.
Contact us before ordering from F1~F49

ISO CODE

MCLN 95°

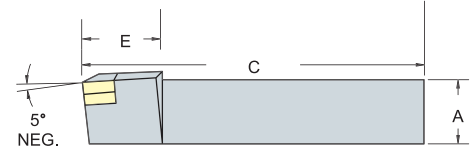
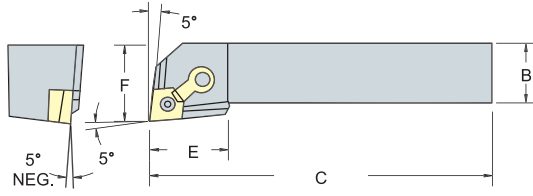

RIGHT HAND SHOWN LEFT HAND OPPOSITE

ORDER NO.		INSERT	DIMENSIONS				PARTS				WEIGHT (kg)		CODE NO.		
Righthand	Lefthand		A	B	C	E	F					Right	Left	Right	Left
MCLNR-1616H12	MCLNL-1616H12	CNMG 12 04 08	16	16	100	30	20	SMC-432	LCS-617	CP50-22	CS7-6024	0.25	0.25	6005-001	6005-101
MCLNR-2020K12	MCLNL-2020K12	CNMG 12 04 08	20	20	125	34	25	SMC-432	LCS-617	CP50-22	CS7-6030	0.45	0.45	6005-002	6005-102
MCLNR-2525M12	MCLNL-2525M12	CNMG 12 04 08	25	25	150	34	32	SMC-432	LCS-617	CP50-22	CS7-6030	0.80	0.80	6005-003	6005-103
MCLNR-3225P12	MCLNL-3225P12	CNMG 12 04 08	32	25	170	34	32	SMC-432	LCS-617	CP50-22	CS7-6030	1.20	1.20	6005-004	6005-104

MCRN 75°

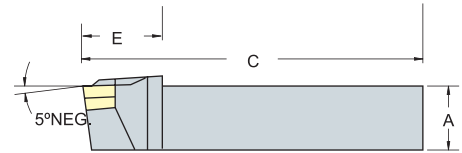
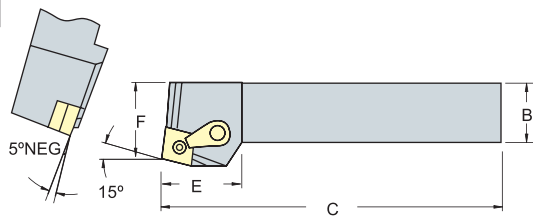

RIGHT HAND SHOWN LEFT HAND OPPOSITE

ORDER NO.		INSERT	DIMENSIONS				PARTS				WEIGHT (kg)		CODE NO.		
Righthand	Lefthand		A	B	C	E	F					Right	Left	Right	Left
MCRNR-2020K12	MCRNL-2020K12	CNMG 12 04 08	20	20	125	37	25	SMC-432	LCS-617	CP50-22	CS7-6030	0.45	0.45	6005-030	6005-130
MCRNR-2525M12	MCRNL-2525M12	CNMG 12 04 08	25	25	150	34	32	SMC-432	LCS-617	CP50-22	CS7-6030	0.80	0.80	6005-031	6005-131
MCRNR-3225P12	-	CNMG 12 04 08	32	25	170	34	32	SMC-432	LCS-617	CP50-22	CS7-6030	1.20	-	6005-032	-

MTJN 93°

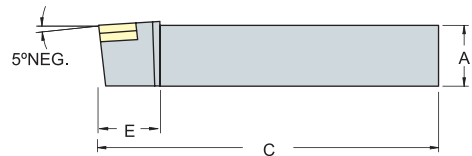
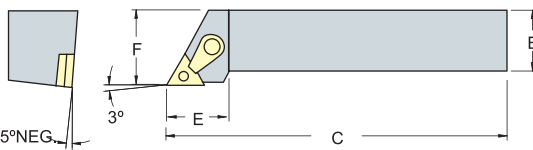

RIGHT HAND SHOWN LEFT HAND OPPOSITE

ORDER NO.		INSERT	DIMENSIONS				PARTS				WEIGHT (kg)		CODE NO.		
Righthand	Lefthand		A	B	C	E	F					Right	Left	Right	Left
MTJNR-2020K16	MTJNL-2020K16	TNMG 16 04 08	20	20	125	33	25	SMT-322	LCS-513	CP50-22	CS7-6024	0.45	0.45	6005-060	6005-160
MTJNR-2525M16	MTJNL-2525M16	TNMG 16 04 08	25	25	150	35	32	SMT-322	LCS-513	CP50-22	CS7-6030	0.80	0.80	6005-061	6005-161

MTEN 60°



NEUTRAL HAND

ORDER NO.	INSERT	DIMENSIONS				PARTS				WEIGHT (kg)		CODE NO.
Righthand		A	B	C	E	F					Right	Left
MTENN-2020K16	TNMG 16 04 08	20	20	125	38	10	SMT-322	LCS-513	CP50-22	CS7-6030	0.45	6005-090
MTENN-2525M16	TNMG 16 04 08	25	25	150	40	12.5	SMT-322	LCS-513	CP50-22	CS7-6030	0.80	6005-091

※ All inserts are floating price.

ISO CODE

MSD Contact us before ordering from F1~F49

45°

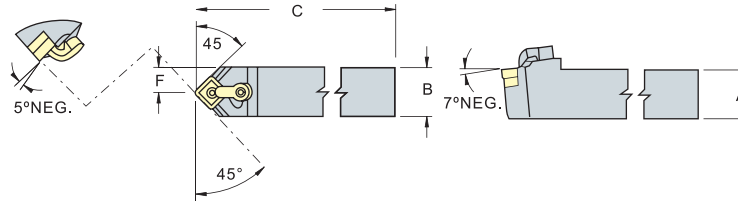

ORDER NO.	INSERT	DIMENSIONS				PARTS				WEIGHT (kg)	CODE NO.
Righthand		A	B	C	F					Right	
MSDNN-2020K12	SN□□1204□□	20	20	125	10	SMS-432	LCS-617	CP50-22	CS7-6030	0.45	6005-120
MSDNN-2525M12	SN□□1204□□	25	25	150	12.5	SMS-432	LCS-617	CP50-22	CS7-6030	0.80	6005-121
MSDNN-3225P12	SN□□1204□□	32	25	170	12.5	SMS-432	LCS-617	CP50-22	CS7-6030	1.20	6005-122

MVVN

72°32'

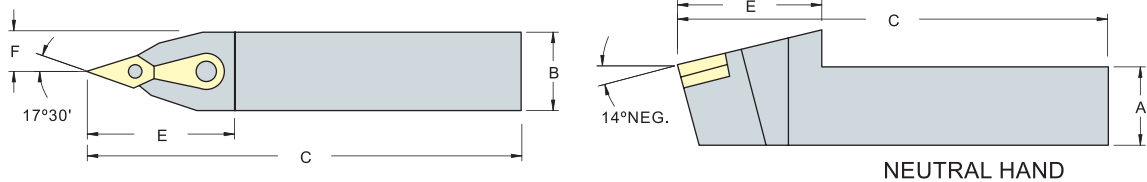

NEUTRAL HAND

ORDER NO.	INSERT	DIMENSIONS						PARTS				WEIGHT (kg)	CODE NO.
Righthand		A	B	C	E	F					Right		
MVVNN-2020K 16K	VNMG 16 04 08	20	20	125	45	10	SMV-322	LCS-513	CP50-25	CS7-6030	0.45	6005-150	
MVVNN-2525M 16K	VNMG 16 04 08	25	25	150	45	12.5	SMV-322	LCS-513	CP50-25	CS7-6030	0.80	6005-151	
MVVNN-3225P 16K	VNMG 16 04 08	32	25	170	45	12.5	SMV-322	LCS-513	CP50-25	CS7-6030	1.20	6005-152	

MDJN

93°

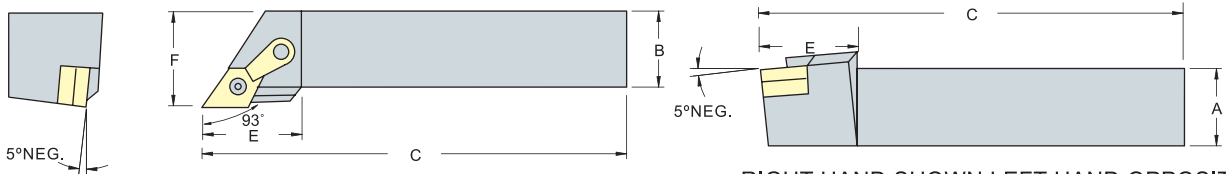

RIGHT HAND SHOWN LEFT HAND OPPOSITE

ORDER NO.	INSERT	DIMENSIONS						PARTS				WEIGHT (kg)		CODE NO.	
Righthand	Lefthand		A	B	C	E	F				Right	Left	Right	Left	
MDJNR-2020K15	MDJNL-2020K15	DNMG 15 04 08	20	20	125	37	25	SMD-463	LCS-619	CP50-24	CS7-6030	0.45	0.45	6005-180	6005-280
MDJNR-2525M15	MDJNL-2525M15	DNMG 15 04 08	25	25	150	37	32	SMD-463	LCS-619	CP50-24	CS7-6030	0.80	0.80	6005-181	6005-281
MDJNR-3225P15	MDJNL-3225P15	DNMG 15 04 08	32	25	170	42	32	SMD-463	LCS-619	CP50-24	CS7-6030	1.20	1.20	6005-182	6005-282

MVJN

93°

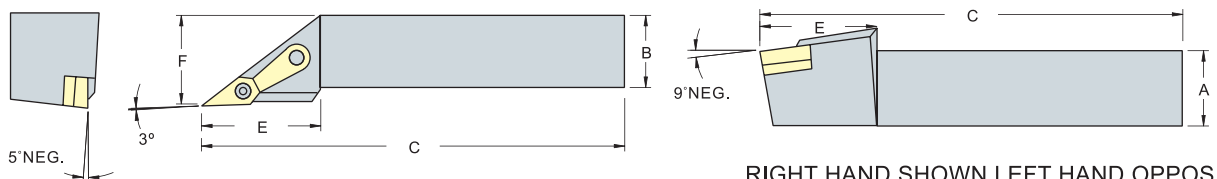

RIGHT HAND SHOWN LEFT HAND OPPOSITE

ORDER NO.	INSERT	DIMENSIONS						PARTS				WEIGHT (kg)		CODE NO.	
Righthand	Lefthand		A	B	C	E	F				Right	Left	Right	Left	
MVJNR-2020K16	MVJNL-2020K16	VNMG 16 04 08	20	20	125	39	25	SMV-322	LCS-513	CP50-25	CS7-6030	0.45	0.45	6005-210	6005-310
MVJNR-2525M16	MVJNL-2525M16	VNMG 16 04 08	25	25	150	44	32	SMV-322	LCS-513	CP50-25	CS7-6030	0.80	0.80	6005-211	6005-311
MVJNR-3225P16	MVJNL-3225P16	VNMG 16 04 08	32	25	170	44	32	SMV-322	LCS-513	CP50-25	CS7-6030	1.20	1.20	6005-212	6005-312

WTJN

93°

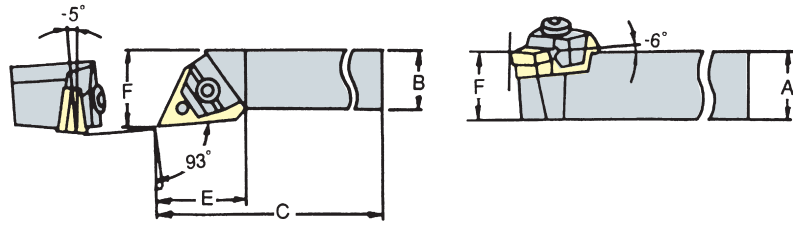

※All inserts are floating price.
Contact us before ordering from F1~F49

ORDER NO.		INSERT	DIMENSIONS						PARTS					WEIGHT(kg)		CODE NO.	
Righthand	Lefthand		A	B	C	E	F						Right	Left	Right	Left	
WTJNR-2020K16	WTJNL-2020K16	TNMG 16 04 08	20	20	125	32	25	SMT-322	LCS-420N	LCS-4B	MWW-30	CS70-24	LW030	0.45	0.45	6005-240	6005-340
WTJNR-2525M16	WTJNL-2525M16	TNMG 16 04 08	25	25	150	32	32	SMT-322	LCS-420N	LCS-4B	MWW-30	CS70-24	LW030	0.80	0.80	6005-241	6005-341

WTEN

60°

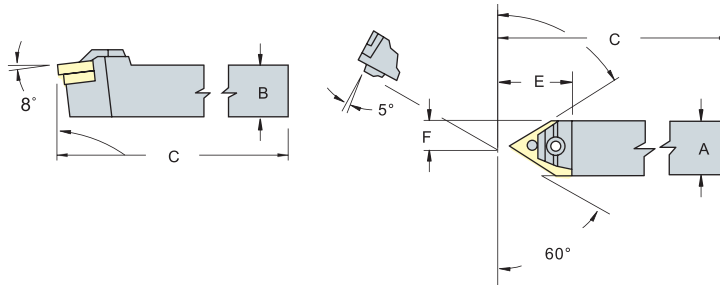

ORDER NO.	INSERT	DIMENSIONS						PARTS					WEIGHT (kg)	CODE NO.
Righthand		A	B	C	E	F							Right	
WTENN-2020K16	TNMG 16 04 08	20	20	125	32	10	SMT-322	LCS-420N	LCS-4B	MWW-30	CS70-24	LW030	0.45	6005-270
WTENN-2525M16	TNMG 16 04 08	25	25	150	38	12.5	SMT-322	LCS-420N	LCS-4B	MWW-30	CS70-24	LW030	0.80	6005-271

WTXN

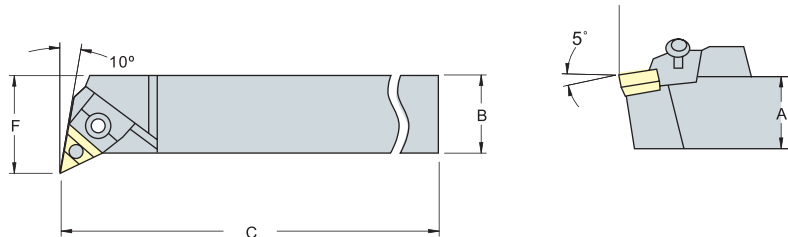

ORDER NO.		INSERT	DIMENSIONS						PARTS					WEIGHT(kg)		CODE NO.	
Righthand	Lefthand		A	B	C	E	F						Right	Left	Right	Left	
WTXNR-2020K16	WTXNL-2020K16	TNMG 16 04 08	20	20	125	32	25	SMT-322	LCS-420N	LCS-4B	MWW-30	CS70-24	LW030	0.45	0.45	6005-300	6005-400
WTXNR-2525M16	WTXNL-2525M16	TNMG 16 04 08	25	25	150	32	32	SMT-322	LCS-420N	LCS-4B	MWW-30	CS70-24	LW030	0.80	0.80	6005-301	6005-401

WWLN

95°

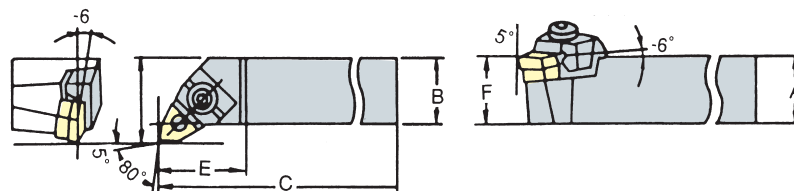

ORDER NO.		INSERT	DIMENSIONS						PARTS					WEIGHT(kg)		CODE NO.	
Righthand	Lefthand		A	B	C	E	F						Right	Left	Right	Left	
WWLNR-2020K08	WWLNL-2020K08	WNMG 08 04 08	20	20	125	32	25	SMW-433	LCS-520N	LCS-5B	MMW-40	CS70-25	LW040 & LW025	0.45	0.45	6005-330	6005-430
WWLNR-2525M08	WWLNL-2525M08	WNMG 08 04 08	25	25	150	32	32	SMW-433	LCS-520N	LCS-5B	MMW-40	CS70-25	LW040 & LW025	0.80	0.80	6005-331	6005-431
WWLNR-3225P08	WWLNL-3225P08	WNMG 08 04 08	32	25	170	32	32	SMW-433	LCS-520N	LCS-5B	MMW-40	CS70-25	LW040 & LW025	1.20	1.20	6005-332	6005-432

SCLC

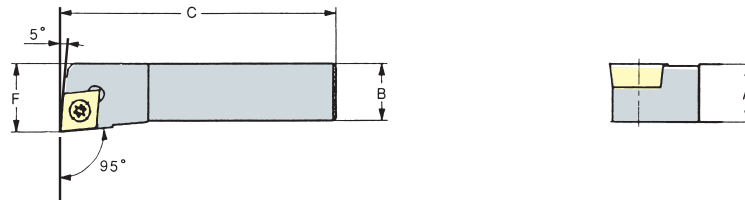

※All inserts are floating price.
Contact us before ordering from F1~F49

ORDER NO.		INSERT	DIMENSIONS				PARTS		WEIGHT (kg)		CODE NO.	
Righthand	Lefthand		A	B	C	F			Right	Left	Right	Left
SCLCR-0808H06	SCLCL-0808H06	CC□□0602□□	8	8	100	10	CS2560	FT-7	0.06	0.06	6005-360	6005-460
SCLCR-1010H06	SCLCL-1010H06	CC□□0602□□	10	10	100	12	CS2560	FT-7	0.08	0.08	6005-361	6005-461
SCLCR-1212H09	SCLCL-1212H09	CC□□09T3□□	12	12	100	16	CS3590	FT-15	0.12	0.12	6005-362	6005-462
SCLCR-1616H09	SCLCL-1616H09	CC□□09T3□□	16	16	100	20	CS3590	FT-15	0.21	0.21	6005-363	6005-463

SDJC

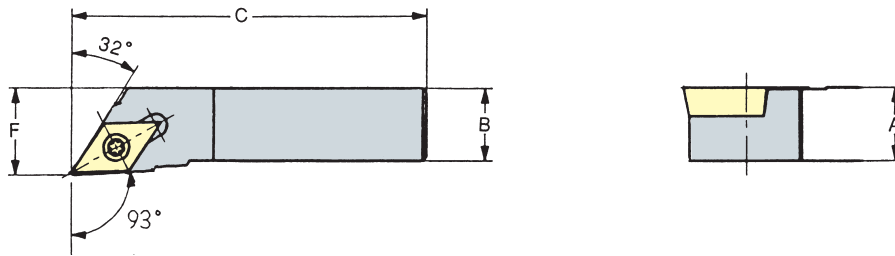

ORDER NO.		INSERT	DIMENSIONS				PARTS		WEIGHT (kg)		CODE NO.	
Righthand	Lefthand		A	B	C	F			Right	Left	Right	Left
SDJCR-0808H07	SDJCL-0808H07	DC□□0702□□	8	8	100	10	CS2560	FT-7	0.06	0.06	6005-390	6005-490
SDJCR-1010H07	SDJCL-1010H07	DC□□0702□□	10	10	100	12	CS2560	FT-7	0.08	0.08	6005-391	6005-491
SDJCR-1212H11	SDJCL-1212H11	DC□□11T3□□	12	12	100	16	CS35095	FT-15	0.12	0.12	6005-392	6005-492
SDJCR-1616H11	SDJCL-1616H11	DC□□11T3□□	16	16	100	20	CS35095	FT-15	0.21	0.21	6005-393	6005-493

SVJC

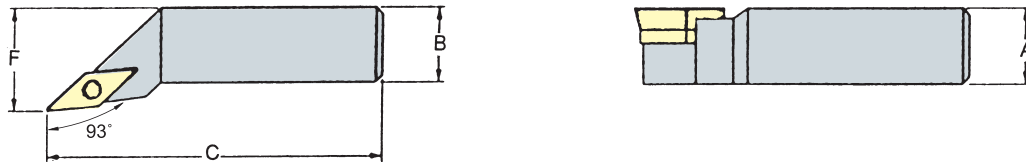

ORDER NO.		INSERT	DIMENSIONS				PARTS			WEIGHT (kg)		CODE NO.		
Righthand	Lefthand		A	B	C	F				Right	Left	Right	Left	
SVJCR-1010H11	SVJCL-1010H11	VC□□1103□□	10	10	100	10.5	-	-	CS2560	FT-7	0.08	0.08	6005-420	6005-520
SVJCR-1212H11	SVJCL-1212H11	VC□□1103□□	12	12	100	12.5	-	-	CS2560	FT-7	0.12	0.12	6005-421	6005-521
SVJCR-1616H11	SVJCL-1616H11	VC□□1103□□	16	16	100	16.5	-	-	CS2560	FT-7	0.21	0.21	6005-422	6005-522
SVJCR-2020K16	SVJCL-2020K16	VC□□1604□□	20	20	125	25	SMV-321	SN535	CS35115	FT-15	0.40	0.40	6005-423	6005-523
SVJCR-2525M16	SVJCL-2525M16	VC□□1604□□	25	25	150	32	SMV-321	SN535	CS35115	FT-15	0.72	0.72	6005-424	6005-524

SVVC

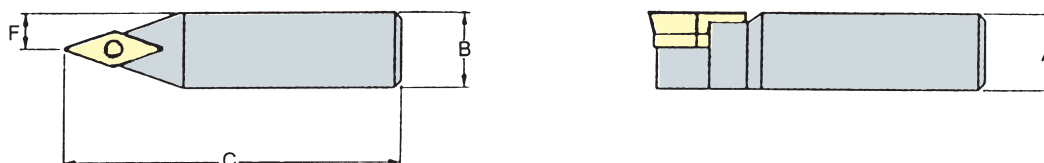

ORDER NO.	INSERT	DIMENSIONS				PARTS				WEIGHT (kg)		CODE NO.
		A	B	C	F					Right	Left	
SVVCN-1010H11	VC□□1103□□	10	10	100	5	-	-	CS2560	FT-7	0.08	0.08	6005-450
SVVCN-1212H11	VC□□1103□□	12	12	100	6	-	-	CS2560	FT-7	0.12	0.12	6005-451
SVVCN-1616H11	VC□□1103□□	16	16	100	8	-	-	CS2560	FT-7	0.21	0.21	6005-452
SVVCN-2020K16	VC□□1604□□	20	20	125	10	SMV-321	SN535	CS35115	FT-15	0.40	0.40	6005-453
SVVCN-2525M16	VC□□1604□□	25	25	150	12.5	SMV-321	SN535	CS35115	FT-15	0.72	0.72	6005-454

TOOL HOLDERS

MWLN

95°

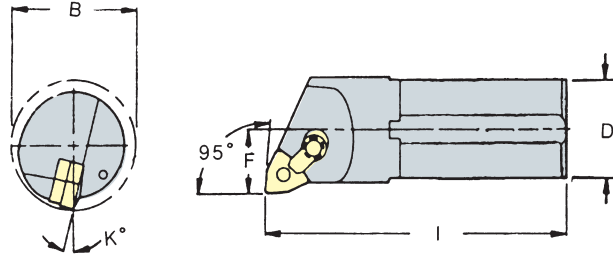

※All inserts are floating price.
Contact us before ordering from F1~F49

ORDER NO.		INSERT	DIMENSIONS					PARTS				WEIGHT (kg)		CODE NO.	
Righthand	Lefthand		D	F	I	B	K°					Right	Left	Right	Left
S20R-MWLN08	S20R-MWLN08	WNMG 08 04	20	13	200	25	17°	-	LCS-511	CP50-26	CS7-5018	0.50	0.50	6005-480	6005-580
S25R-MWLN08	S25R-MWLN08	WNMG 08 04	25	17	200	32	14°	-	LCS-511	CP50-22	CS7-6024	0.95	0.95	6005-481	6005-581
S32S-MWLN08	S32S-MWLN08	WNMG 08 04	32	22	250	40	14°	SMW-432	LCS-617	CP50-22	CS7-6030	1.60	1.60	6005-482	6005-582
S40T-MWLN08	S40T-MWLN08	WNMG 08 04	40	27	300	50	12°	SMW-432	LCS-617	CP50-22	CS7-6030	2.90	2.90	6005-483	6005-583
S50U-MWLN08	S50U-MWLN08	WNMG 08 04	50	35	350	63	12°	SMW-432	LCS-617	CP50-22	CS7-6030	5.90	5.90	6005-484	6005-584

MCLN

95°

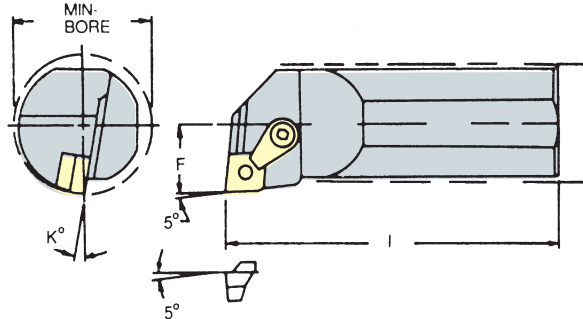

RIGHT HAND SHOWN LEFT HAND OPPOSITE

ORDER NO.		INSERT	DIMENSIONS					PARTS				WEIGHT (kg)		CODE NO.	
Righthand	Lefthand		D	F	I	B	K°					Right	Left	Right	Left
S20R-MCLNR12	S20R-MCLNR12	CNMG 12 04 08	20	13	200	25	17°	-	LCS-511	CP50-26	CS7-5018	0.50	0.50	6005-510	6005-610
S25R-MCLNR12	S25R-MCLNR12	CNMG 12 04 08	25	17	200	32	14°	-	LCS-511	CP50-22	CS7-6024	0.95	0.95	6005-511	6005-611
S32S-MCLNR12	S32S-MCLNR12	CNMG 12 04 08	32	22	250	40	14°	SMC-432	LCS-617	CP50-22	CS7-6030	1.60	1.60	6005-512	6005-612
S40T-MCLNR12	S40T-MCLNR12	CNMG 12 04 08	40	27	300	50	12°	SMC-432	LCS-617	CP50-22	CS7-6030	2.90	2.90	6005-513	6005-613
S50U-MCLNR12	S50U-MCLNR12	CNMG 12 04 08	50	35	350	63	12°	SMC-432	LCS-617	CP50-22	CS7-6030	5.90	5.90	6005-514	6005-614

MDUN

93°

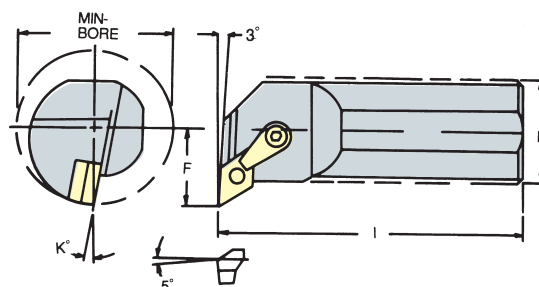

RIGHT HAND SHOWN LEFT HAND OPPOSITE

ORDER NO.		INSERT	DIMENSIONS					PARTS				WEIGHT (kg)		CODE NO.	
Righthand	Lefthand		D	F	I	B	K°					Right	Left	Right	Left
S25R-MDUNR15	S25R-MDUNR15	DNMG 15 04 08	25	17	200	32	12°	SMD-443	LCS-617	CS50-24	CS7-6024	0.95	0.95	6005-540	6005-640
S32S-MDUNR15	S32S-MDUNR15	DNMG 15 04 08	32	22	250	40	10°	SMD-443	LCS-617	CS50-24	CS7-6024	1.60	1.60	6005-541	6005-641
S40T-MDUNR15	S40T-MDUNR15	DNMG 15 04 08	40	27	300	50	10°	SMD-443	LCS-617	CS50-24	CS7-6030	2.90	2.90	6005-542	6005-642
S50U-MDUNR15	S50U-MDUNR15	DNMG 15 04 08	50	35	350	63	10°	SMD-443	LCS-617	CS50-24	CS7-6030	5.90	5.90	6005-543	6005-643



Boring Bars

SMALL SIZE

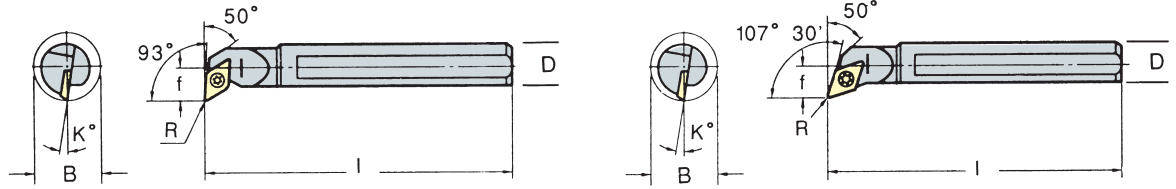

※All inserts are floating price.

Contact us before ordering from F1~F49

ORDER NO.		DIMENSIONS					INSERT	PARTS		WEIGHT (kg)		CODE NO.	
Righthand	Lefthand	D	F	I	B	K°				Right	Left	Right	Left
S10M-SDUCR07	S10M-SDUCL07	10	7	150	13	10°	DCMT 0702□□	CS2560	FT-7	0.15	0.15	6005-570	6005-670
S12M-SDUCR07	S12M-SDUCL07	12	9	150	16	8°				0.18	0.18	6005-571	6005-671
S16Q-SDUCR07	S16Q-SDUCL07	16	11	180	20	6°				0.28	0.28	6005-572	6005-672
S20R-SDUCR11	S20R-SDUCL11	20	13	200	25	8°	DCMT 11T3□□	CS35095	FT-15	0.45	0.45	6005-573	6005-673
S25R-SDUCR11	S25R-SDUCL11	25	17	200	32	4°				0.60	0.60	6005-574	6005-674
S10M-SDQCR07	S10M-SDQCL07	10	7	150	13	10°	DCMT 0702□□	CS2560	FT-7	0.15	0.15	6005-600	6005-700
S12M-SDQCR07	S12M-SDQCL07	12	9	150	16	8°				0.18	0.18	6005-601	6005-701
S16Q-SDQCR07	S16Q-SDQCL07	16	11	180	20	6°				0.28	0.28	6005-602	6005-702
S20R-SDQCR11	S20R-SDQCL11	20	13	200	25	8°	DCMT 11T3□□	CS35095	FT-15	0.45	0.45	6005-603	6005-703
S25R-SDQCR11	S25R-SDQCL11	25	17	200	32	4°				0.60	0.60	6005-604	6005-704

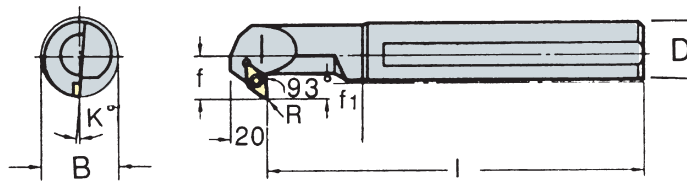

ORDER NO.		DIMENSIONS					INSERT	PARTS		WEIGHT (kg)		CODE NO.	
Righthand	Lefthand	D	F	I	B	K°				Right	Left	Right	Left
S12M-SDZCR07	S12M-SDZCL07	12	10.5	150	17	10°	DCMT 0702□□	CS2560	FT-7	0.18	0.18	6005-630	6005-730
S16Q-SDZCR07	S16Q-SDZCL07	16	12.5	180	21	9°				0.28	0.28	6005-631	6005-731
S20R-SDZCR11	S20R-SDZCL11	20	15.5	200	26	8°	DCMT 11T3□□	CS35095	FT-15	0.45	0.45	6005-632	6005-732
S25R-SDZCR11	S25R-SDZCL11	25	18	200	33	6°				0.60	0.60	6005-633	6005-733

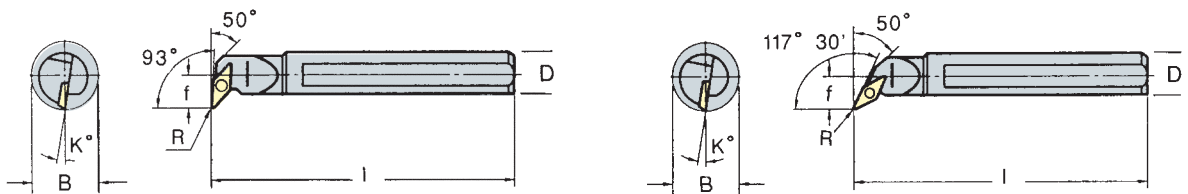

ORDER NO.		DIMENSIONS					INSERT	PARTS		WEIGHT (kg)		CODE NO.	
Righthand	Lefthand	D	F	I	B	K°				Right	Left	Right	Left
S16Q-SVUCR11	S16Q-SVUCL11	16	13	180	22	7°	VCMT 1103□□	CS2560	FT-7	0.28	0.28	6005-660	6005-760
S20R-SVUCR11	S20R-SVUCL11	20	15	200	27	6°				0.45	0.45	6005-661	6005-761
S25R-SVUCR16	S25R-SVUCL16	25	20.5	200	33	4°	VCMT 1604	CS3590	FT-15	0.60	0.60	6005-662	6005-762
S16Q-SVQCR11	S16Q-SVQCL11	16	13	180	22	7°	VCMT 1103□□	CS2560	FT-7	0.28	0.28	6005-690	6005-790
S20R-SVQCR11	S20R-SVQCL11	20	15	200	27	6°				0.45	0.45	6005-691	6005-791
S25R-SVQCR16	S25R-SVQCL16	25	20.5	200	33	4°	VCMT 1604	CS3590	FT-15	0.60	0.60	6005-692	6005-792

BORING BAR



Technical Data

Milling & Turning Insert Identification



2 Relief angle

tolerances						
IC: theoretical diameter of the insert inscribed circle T: thickness B: see figure below						
tolerance class	tolerance on "IC"		tolerance on "B"		tolerance on "T"	
	in	mm	in	mm	in	mm
C	±0.010	±0.025	±0.0005	±0.013	±0.001	±0.025
H	±0.005	±0.013	±0.0005	±0.013	±0.001	±0.025
E	±0.010	±0.025	±0.0010	±0.025	±0.001	±0.025
G	±0.010	±0.025	±0.0010	±0.025	±0.005	±0.13
M	see tables at right		see tables at right		±0.005	±0.13
U	see tables at right		see tables at right		±0.005	±0.13

3 tolerance

1 Shape

4 Insert type

inch	C	N	M	G	-	4	3	2			
(metric)	C	N	M	G		12	04	08			
position	1	2	3	4		5	6	7	8	9	10

5 Size										
inch	IC		metric cutting edge length							
	in	mm	C	D	R	S	T	V	W	
1.2 (5)	5/22	3.97	-	04	03	03	06	-	-	
1.5 (6)	3/16	4.76	04	05	04	04	08	08	-	
1.8 (7)	7/22	5.56	05	06	05	05	09	09	03	
-	0.236	6.00	-	-	06	-	-	-	-	
2	1/4	6.35	06	07	06	06	11	11	04	
2.5	5/16	7.94	08	09	07	07	13	13	05	
-	0.315	8.00	-	-	08	-	-	-	-	
3	3/8	9.52	09	11	09	09	16	16	06	
-	0.394	10.00	-	-	10	-	-	-	-	
3.5	1/16	11.11	11	13	11	11	19	19	07	
-	0.472	12.00	-	-	12	-	-	-	-	
4	1/2	12.70	12	15	12	12	22	22	08	
4.5	9/16	14.29	14	17	14	14	24	24	09	
5	5/8	15.88	16	19	15	15	27	27	10	
-	0.630	16.00	-	-	16	-	-	-	-	
5.5	11/16	17.46	17	21	17	17	30	30	11	
6	3/4	19.05	19	23	19	19	33	33	13	
-	0.787	20.00	-	-	20	-	-	-	-	
7	7/8	22.22	22	27	22	22	38	38	15	
-	0.984	25.00	-	-	25	-	3	-	-	
8	1	25.40	25	31	25	25	44	44	17	
10	1-1/4	31.75	32	38	31	31	54	54	21	
-	1.260	32.00	-	-	32	-	-	-	-	

6 thickness			
thickness		symbol	
in	mm	inch	metric
1/32	0.79	0.5(1)	-
1/16	1.59	1(2)	01
5/64	1.98	1.2	T1
3/32	2.38	1.5(3)	02
1/8	3.18	2	03
5/22	3.97	2.5	T3
3/16	4.76	3	04
7/32	5.56	3.5	05
1/4	6.35	4	06
5/16	7.94	5	07
3/8	9.52	6	09
7/16	11.11	7	11
1/2	12.70	8	12

NOTE: Inch sizes in parenthesis for "Alternate sizes" D or E (under 1/4 inch IC.)

8 hand of insert (optional)	

7 corner radius			
corner radius		symbol	
in	mm	inch	metric
.004	0.1	0	01
.008	0.2	0.5	02
1/64	0.4	1	04
1/32	0.8	2	08
3/64	1.2	3	12
1/16	1.6	4	16
5/64	2.0	5	20
3/32	2.4	6	24
7/64	2.8	7	28
1/8	3.2	8	32
round insert (inch)	-	-	00
round insert (metric)	-	-	M0

9 & 10 cutting edge condition or chip control features (optional)	
T	negative land
K	light feed chip control. double sided Kenioc insert
M	heavy feed chip control. deep floor Kenioc
N	narrow land control insert with chip control on one side
W	heavy-duty chip control. wide land Kenioc insert one side
J	polished to 4-microinch A4 (rake face only)
UF	ultra-fine finishing
See Technical Section for additional conditions and chip control features	

NOTE: Inch sizes in parenthesis for "alternate sizes" D or E (under 1/4 inch IC.)



Insert For Face Mill Cutter



EXAMPLE

ISO CODE

Positive
Axial Rake
Radial Rake

Positive
Axial Rake
Radial Rake

Positive
Axial Rake
Positive
Radial Rake

Positive
Axial Rake
Radial Rake

45°

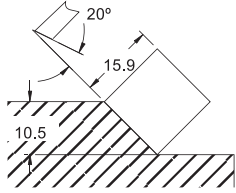

5/8 x 3/16 Insert
SEC 53
SECN 1504
SEKN 1504
FOR SE-545

45°

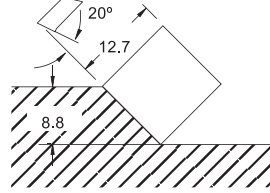

1/2 x 1/8 Insert
SEC 42
SECN 1203
SEKN 1203
FOR SE-445

65°

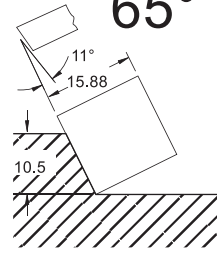

5/8 x 3/16 Insert
SPU-53, SPCN 1504
SPG-53, SPKN 1504
FOR SP-TYPE

75°

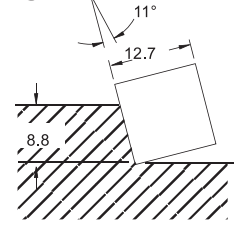

1/2 x 1/8 Insert
SPU-42, SPKN 1203
SPG-42, SPMN 1203
FOR FP-TYPE

Positive
Axial Rake

90°

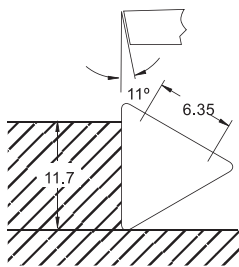

1/4 x 3/32 Insert
TPG-21
TPMN 1102
FOR SAE-TYPE

Positive
Axial Rake

90°

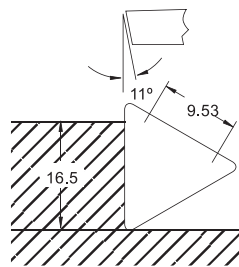

3/8 x 1/8 Insert
TPU-32
TPG-32
TPMN 1603
TPCN 1603
FOR SAE-TYPE

Positive
Axial Rake
Radial Rake

90°

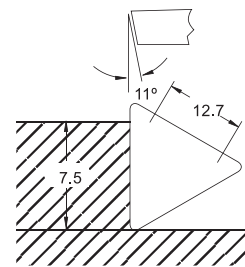

1/2 x 3/16 Insert
TPK-43
TPKN 2204
TPMN 2204
FOR TP-TYPE

※All cutting tools are floating price.
contact us before ordering.



MILL CUTTER



Universal End Mills

Professional For Aluminium, Copper, Steels



CARBIDE

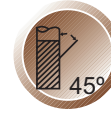

Work Material / Velocity m/min

ORDER NO.	GR.1 Non alloyed steels Alloyed Steels	GR.3 Hardened steels < 48 HRC	GR.9 Copper	GR.10 Aluminium	GR.11 Plastics
VE133	40-120	30-50	100-200	100-450	150-200
VE135	25-70	20-30	60-120	60-300	80-120

Standard Length(Order No. VE133-Dia)

Unit:mm

ORDER NO.	Dc e8	Lc mm	L mm	d h6	CODE NO.
VE133-1.0	1.0	3	38	3	6007-460
VE133-1.5	1.5	5	38	3	6007-461
VE133-2.0	2.0	6	38	3	6007-462
VE133-2.5	2.5	7	38	3	6007-463
VE133-3.0	3.0	9	38	3	6007-464
VE133-4.0	4.0	14	50	4	6007-465
VE133-5.0	5.0	16	50	5	6007-466
VE133-6.0	6.0	20	63	6	6007-467
VE133-7.0	7.0	20	63	8	6007-468
VE133-8.0	8.0	20	63	8	6007-469
VE133-9.0	9.0	22	72	10	6007-470
VE133-10.0	10.0	22	72	10	6007-471
VE133-12.0	12.0	26	75	12	6007-472
VE133-14.0	14.0	30	89	14	6007-473
VE133-16.0	16.0	32	89	16	6007-474
VE133-18.0	18.0	38	100	18	6007-475
VE133-20.0	20.0	38	100	20	6007-476

Long Length(Order No. VE135-Dia)

Unit:mm

ORDER NO.	Dc e8	Lc mm	L mm	d h6	CODE NO.
VE135-3	3	20	57	3	6007-480
VE135-4	4	20	57	4	6007-481
VE135-5	5	25	63	5	6007-482
VE135-6	6	28	75	6	6007-483
VE135-7	7	30	75	8	6007-484
VE135-8	8	30	75	8	6007-485
VE135-9	9	32	75	10	6007-486
VE135-10	10	32	75	10	6007-487
VE135-12	12	50	100	12	6007-488
VE135-14	14	57	127	14	6007-489
VE135-16	16	57	127	16	6007-490
VE135-20	20	57	127	20	6007-491



IT'S A VERTEX EXCELENT CARBIDE END MILL

GOOD MATERIAL



GOOD PROCESS MACHINE



GOOD COATING EQUIPMENT





Universal End Mills



CARBIDE

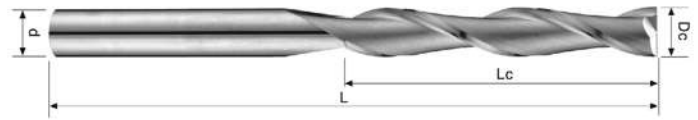
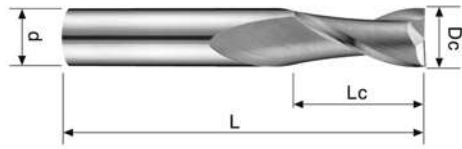

Work Material / Velocity m/min

ORDER NO.	GR.1 Non alloyed steels Alloyed Steels	GR.3 Hardened steels < 48 HRC	GR.6 Iron	GR.9 Copper	GR.10 Aluminium	GR.11 Plastics
VEA72	40-120	30-50	40-80	100-200	100-450	150-180
VEA82	25-70	20-50	25-60	60-120	60-300	80-120

Standard Length(Order No. VEA72-Dia)

Unit:mm

ORDER NO.	Dc h10	Lc mm	L mm	d h6	CODE NO.
VEA72-0.3	0.3	0.8	38	3	6008-001
VEA72-0.5	0.5	1.2	38	3	6008-003
VEA72-0.6	0.6	1.5	38	3	6008-004
VEA72-1.0	1.0	3.0	38	3	6008-008
VEA72-1.5	1.5	5.0	38	3	6008-009
VEA72-2.0	2.0	6.0	38	3	6008-010
VEA72-2.5	2.5	7.0	38	3	6008-011
VEA72-3.0	3.0	9.0	38	3	6008-012
VEA72-4.0	4.0	14.0	50	4	6008-014
VEA72-5.0	5.0	16.0	50	5	6008-016
VEA72-5.5	5.5	16.0	50	6	6008-017
VEA72-6.0	6.0	20.0	63	6	6008-018
VEA72-7.0	7.0	20.0	63	8	6008-019
VEA72-8.0	8.0	20.0	63	8	6008-020
VEA72-9.0	9.0	22.0	72	10	6008-021
VEA72-10.0	10.0	22.0	72	10	6008-022
VEA72-12.0	12.0	26.0	75	12	6008-024
VEA72-16.0	16.0	32.0	89	16	6008-026
VEA72-20.0	20.0	38.0	100	20	6008-028

Long Length(Order No. VEA82-Dia)

Unit:mm

ORDER NO.	Dc h10	Lc mm	L mm	d h6	CODE NO.
VEA82-3	3	20	57	3	6008-040
VEA82-4	4	20	57	4	6008-041
VEA82-5	5	25	63	5	6008-042
VEA82-6	6	28	75	6	6008-043
VEA82-8	8	30	75	8	6008-044
VEA82-10	10	32	75	10	6008-045
VEA82-12	12	50	100	12	6008-046

END MILLS

CARBIDE

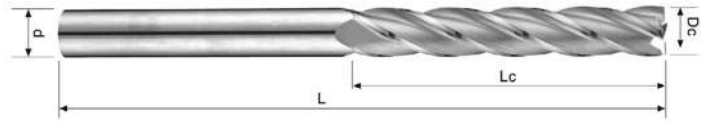
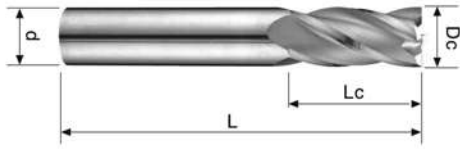

Work Material / Velocity m/min

ORDER NO.	GR.1 Non alloyed steels Alloyed Steels	GR.3 Hardened steels < 48 HRC	GR.6 Iron	GR.7 Titanium	GR.8 Nickel	GR.9 Copper	GR.10 Aluminium
VEA74	40-120	30-50	40-80	25-80	20-60	100-200	100-450
VEA84	25-70	20-30	25-60	15-50	15-35	60-120	60-300

Standard Length(Order No. VEA74-Dia) Unit:mm

ORDER NO.	Dc h10	Lc mm	L mm	d h6	CODE NO.
VEA74-1.0	1.0	3	38	3	6008-060
VEA74-1.5	1.5	5	38	3	6008-061
VEA74-2.0	2.0	6	38	3	6008-062
VEA74-2.5	2.5	7	38	3	6008-063
VEA74-3.0	3.0	9	38	3	6008-064
VEA74-3.5	3.5	12	50	4	6008-065
VEA74-4.0	4.0	14	50	4	6008-066
VEA74-4.5	4.5	14	50	5	6008-067
VEA74-5.0	5.0	16	50	5	6008-068
VEA74-5.5	5.5	16	50	6	6008-069
VEA74-6.0	6.0	20	63	6	6008-070
VEA74-7.0	7.0	20	63	8	6008-071
VEA74-8.0	8.0	20	63	8	6008-072
VEA74-9.0	9.0	22	72	10	6008-073
VEA74-10.0	10.0	22	72	10	6008-074
VEA74-11.0	11.0	26	75	12	6008-075
VEA74-12.0	12.0	26	75	12	6008-076
VEA74-14.0	14.0	32	89	14	6008-077
VEA74-16.0	16.0	32	89	16	6008-078
VEA74-18.0	18.0	38	100	18	6008-079
VEA74-20.0	20.0	38	100	20	6008-080

Long Length(Order No. VEA84-Dia) Unit:mm

ORDER NO.	Dc h10	Lc mm	L mm	d h6	CODE NO.
VEA84-3	3	20	57	3	6008-090
VEA84-4	4	20	57	4	6008-091
VEA84-5	5	25	63	5	6008-092
VEA84-6	6	28	75	6	6008-093
VEA84-8	8	30	75	8	6008-094
VEA84-10	10	32	75	10	6008-095
VEA84-12	12	50	100	12	6008-096
VEA84-16	16	57	127	16	6008-098
VEA84-20	20	57	127	20	6008-099





Ball Nose End Mills

CARBIDE

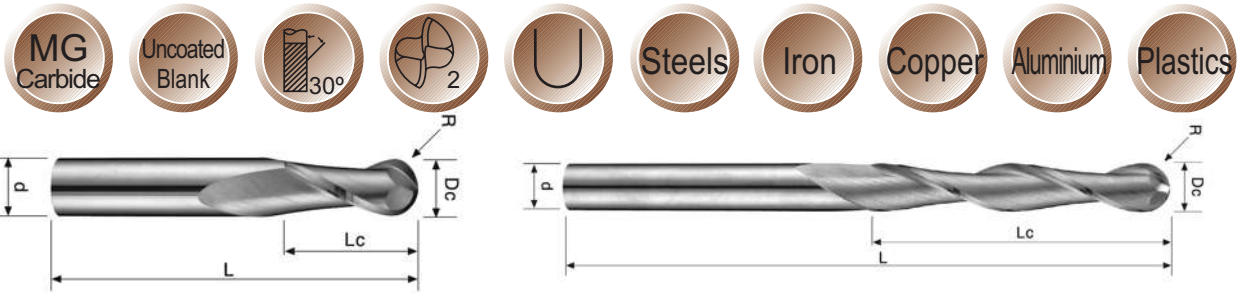

Work Material / Velocity m/min

ORDER NO.	GR.1 Non alloyed steels Alloyed Steels	GR.3 Hardened steels < 48 HRC	GR.6 Iron	GR.9 Copper	GR.10 Aluminium	GR.11 Plastics
VBB12	40-120	30-50	40-80	60-120	60-300	80-120
VBB80	25-70	20-30	25-60	60-120	60-300	80-120

Standard Length(Order No. VBB12-Dia) Unit:mm

ORDER NO.	Dc h10	R ±0.01	Lc mm	L mm	d h6	CODE NO.
VBB12-0.3	0.3	0.15R	0.6	38	3	6008-100
VBB12-0.5	0.5	0.25R	1.0	38	3	6008-102
VBB12-0.7	0.7	0.35R	1.4	38	3	6008-104
VBB12-1.0	1.0	0.50R	3.0	38	3	6008-107
VBB12-1.5	1.5	0.75R	5.0	38	3	6008-108
VBB12-2.0	2.0	1.00R	6.0	38	3	6008-109
VBB12-2.5	2.5	1.25R	7.0	38	3	6008-110
VBB12-3.0	3.0	1.50R	9.0	38	3	6008-111
VBB12-3.5	3.5	1.75R	12.0	50	4	6008-112
VBB12-4.0	4.0	2.00R	14.0	50	4	6008-113
VBB12-4.5	4.5	2.25R	16.0	50	5	6008-114
VBB12-5.0	5.0	2.50R	16.0	50	5	6008-115
VBB12-5.5	5.5	2.75R	16.0	50	6	6008-116
VBB12-6.0	6.0	3.00R	20.0	63	6	6008-117
VBB12-7.0	7.0	3.50R	20.0	63	8	6008-118
VBB12-8.0	8.0	4.00R	20.0	63	8	6008-119
VBB12-9.0	9.0	4.50R	22.0	72	10	6008-120

Standard Length(Order No. VBB12-Dia) Unit:mm

ORDER NO.	Dc h10	R ±0.01	Lc mm	L mm	d h6	CODE NO.
VBB12-10.0	10.0	5.00R	22.0	72	10	6008-121
VBB12-12.0	12.0	6.00R	26.0	75	12	6008-123
VBB12-14.0	14.0	7.00R	32.0	89	14	6008-124
VBB12-16.0	16.0	8.00R	32.0	89	16	6008-125

Long Length(Order No. VBB80-Dia) Unit:mm

ORDER NO.	Dc h10	R ±0.01	Lc mm	L mm	d h6	CODE NO.
VBB80-3	3	1.5R	20	57	3	6008-140
VBB80-4	4	2.0R	20	57	4	6008-141
VBB80-6	6	3.0R	28	75	6	6008-143
VBB80-8	8	4.0R	30	75	8	6008-144
VBB80-12	12	6.0R	50	100	12	6008-146



End Mills For Aluminium

CARBIDE

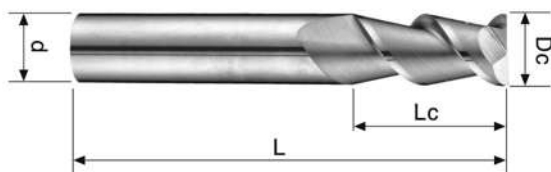
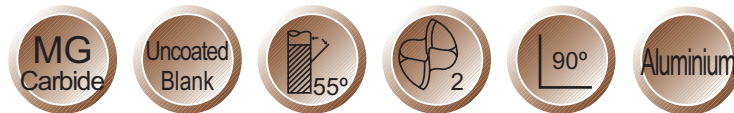

Work Material / Velocity m/min

GR.10 Aluminium
100-1200

Standard Length(Order No. VEA92-Dia) Unit:mm

ORDER NO.	Dc h6	Lc mm	L mm	d h6	CODE NO.
VEA92-3	3	9	38	3	6008-160
VEA92-4	4	14	50	4	6008-161
VEA92-5	5	16	50	5	6008-162
VEA92-6	6	20	63	6	6008-163
VEA92-8	8	22	63	8	6008-164
VEA92-10	10	30	72	10	6008-165
VEA92-12	12	30	75	12	6008-166
VEA92-16	16	40	100	16	6008-167
VEA92-20	20	45	100	20	6008-168



Solid Carbide End Mills For <48HRC



VERTEX®

Micro Grain 10% Co Grade
2 Flute

ISO CODE

CARBIDE

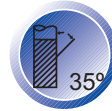

Work Material / Velocity m/min

ORDER NO.	GR.1 Non alloyed steels Alloyed Steels	GR.2 Heat resistant steels Stainless steels	GR.3 Hardened steels < 48 HRC	GR.6 Iron	GR.7 Titanium	GR.8 Nickel	GR.9 Copper
VE112F	60-250	30-100	60-80	30-150	30-180	40-120	100-450
VE122F							
VE125F	60-180	20-80	40-80	30-130	30-120	40-100	100-300
VE127F							

Standard Length(Order No. VE122F-Dia)

Unit:mm

ORDER NO.	Dia of Mill Tol e8	Shank Dia mm	Flute Length mm	Overall Length mm	CODE NO.
VE122-1.0	1.0	4	3	50	6007-020
VE122-1.5	1.5	4	5	50	6007-021
VE122-2.0	2.0	4	6	50	6007-022
VE122-2.5	2.5	4	8	50	6007-023
VE122-3.0	3.0	6	8	50	6007-024
VE122-3.5	3.5	6	10	50	6007-025
VE122-4.0	4.0	6	11	50	6007-026
VE122-4.5	4.5	6	11	50	6007-027
VE122-5.0	5.0	6	13	50	6007-028
VE122-5.5	5.5	6	13	50	6007-029
VE122-6.0	6.0	6	16	50	6007-030
VE122-7.0	7.0	8	20	60	6007-031
VE122-8.0	8.0	8	20	60	6007-032
VE122-9.0	9.0	10	22	72	6007-033
VE122-10.0	10.0	10	25	72	6007-034
VE122-11.0	11.0	12	26	75	6007-035
VE122-12.0	12.0	12	30	75	6007-036
VE122-14.0	14.0	16	32	90	6007-037
VE122-16.0	16.0	16	40	100	6007-038
VE122-18.0	18.0	20	40	100	6007-039
VE122-20.0	20.0	20	40	100	6007-040

Stub Length(Order No. VE112F-Dia)

Unit:mm

ORDER NO.	Dia of Mill Tol e8	Shank Dia mm	Flute Length mm	Overall Length mm	CODE NO.
VE112-1.0	1.0	3	3.0	38	6007-001
VE112-1.5	1.5	3	5.0	38	6007-002
VE112-2.0	2.0	3	6.0	38	6007-003
VE112-2.5	2.5	3	8.0	38	6007-004
VE112-3.0	3.0	3	8.0	38	6007-005
VE112-3.5	3.5	4	10.0	50	6007-006
VE112-4.0	4.0	4	11.0	50	6007-007
VE112-4.5	4.5	5	11.0	50	6007-008
VE112-5.0	5.0	5	13.0	50	6007-009
VE112-5.5	5.5	6	13.0	50	6007-010
VE112-6.0	6.0	6	16.0	50	6007-011

Long Length(Order No. VE125F-Dia)

Unit:mm

ORDER NO.	Dia of Mill Tol e8	Shank Dia mm	Flute Length mm	Overall Length mm	CODE NO.
VE125-3	3	6	12	70	6007-050
VE125-4	4	6	15	70	6007-051
VE125-5	5	6	20	80	6007-052
VE125-6	6	6	20	80	6007-053
VE125-8	8	8	25	100	6007-055
VE125-10	10	10	30	100	6007-057
VE125-12	12	12	35	110	6007-059
VE125-14	14	16	40	120	6007-060
VE125-16	16	16	50	140	6007-061
VE125-20	20	20	55	160	6007-062

Extra Long Length(Order No. VE127F-Dia)

Unit:mm

ORDER NO.	Dia of Mill Tol e8	Shank Dia mm	Flute Length mm	Overall Length mm	CODE NO.
VE127-3	3	4	12	80	6007-070
VE127-4	4	4	15	80	6007-071
VE127-5	5	6	20	100	6007-072
VE127-6	6	6	20	100	6007-073
VE127-8	8	8	25	130	6007-074
VE127-10	10	10	30	160	6007-075
VE127-12	12	12	35	180	6007-076
VE127-16	16	16	50	210	6007-077
VE127-20	20	20	55	210	6007-078



Solid Carbide End Mills For <48HRC



Micro Grain 10% Co Grade

ISO CODE

4 Flute

CARBIDE

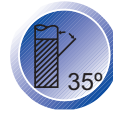

Work Material / Velocity m/min

ORDER NO.	GR.1 Non alloyed steels Alloyed Steels	GR.2 Heat resistant steels Stainless steels	GR.3 Hardened steels < 48 HRC	GR.6 Iron	GR.7 Titanium	GR.8 Nickel	GR.9 Copper
VE114F	60-250	30-100	60-80	30-150	30-180	40-120	100-450
VE124F	60-250	30-100	60-80	30-150	30-180	40-120	100-450
VE126F	60-180	20-80	40-80	30-130	30-120	40-100	100-300

Standard Length(Order No. VE124F-Dia)

Unit:mm

ORDER NO.	Dia of Mill Tol e8	Shank Dia mm	Flute Length mm	Overall Length mm	CODE NO.
VE124-1.0	1.0	4	3	50	6007-100
VE124-1.5	1.5	4	5	50	6007-101
VE124-2.0	2.0	4	6	50	6007-102
VE124-2.5	2.5	4	8	50	6007-103
VE124-3.0	3.0	6	8	50	6007-104
VE124-3.5	3.5	6	10	50	6007-105
VE124-4.0	4.0	6	11	50	6007-106
VE124-4.5	4.5	6	11	50	6007-107
VE124-5.0	5.0	6	13	50	6007-108
VE124-5.5	5.5	6	13	50	6007-109
VE124-6.0	6.0	6	16	50	6007-110
VE124-7.0	7.0	8	20	60	6007-111
VE124-8.0	8.0	8	20	60	6007-112
VE124-9.0	9.0	10	22	72	6007-113
VE124-10.0	10.0	10	25	72	6007-114
VE124-11.0	11.0	12	26	75	6007-115
VE124-12.0	12.0	12	30	75	6007-116
VE124-14.0	14.0	16	32	90	6007-117
VE124-16.0	16.0	16	38	100	6007-118
VE124-18.0	18.0	20	38	100	6007-119
VE124-20.0	20.0	20	38	100	6007-120

Stub Length(Order No. VE114F-Dia)

Unit:mm

ORDER NO.	Dia of Mill Tol e8	Shank Dia mm	Flute Length mm	Overall Length mm	CODE NO.
VE114-1.0	1.0	3	3.0	38	6007-080
VE114-1.5	1.5	3	5.0	38	6007-081
VE114-2.0	2.0	3	6.0	38	6007-082
VE114-2.5	2.5	3	7.0	38	6007-083
VE114-3.0	3.0	3	9.0	38	6007-084
VE114-3.5	3.5	4	10.0	50	6007-085
VE114-4.0	4.0	4	11.0	50	6007-086
VE114-4.5	4.5	5	11.0	50	6007-087
VE114-5.0	5.0	5	13.0	50	6007-088
VE114-5.5	5.5	6	13.0	50	6007-089
VE114-6.0	6.0	6	16.0	50	6007-090

Long Length(Order No. VE126F-Dia)

Unit:mm

ORDER NO.	Dia of Mill Tol e8	Shank Dia mm	Flute Length mm	Overall Length mm	CODE NO.
VE126-3	3	6	12	70	6007-130
VE126-4	4	6	15	70	6007-131
VE126-5	5	6	20	80	6007-132
VE126-6	6	6	20	80	6007-133
VE126-8	8	8	25	100	6007-135
VE126-10	10	10	30	100	6007-137
VE126-12	12	12	35	110	6007-139
VE126-14	14	16	40	120	6007-140
VE126-16	16	16	50	140	6007-141
VE126-20	20	20	55	160	6007-142

END MILLS



Finishing End Mills <56HRC



CARBIDE

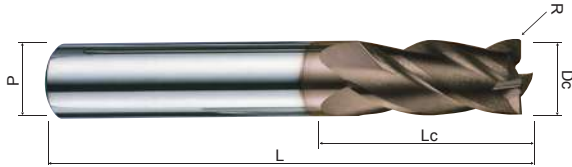
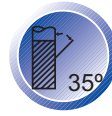

Work Material / Velocity m/min

GR.1 Non alloyed steels Alloyed Steels	GR.2 Heat resistant steels Stainless steels	GR.3 Hardened steels < 48 HRC	GR.4 Hardened steels 48-56 HRC	GR.6 Iron	GR.7 Titanium	GR.8 Nickel
60-300	30-120	60-120	40-100	40-180	40-120	40-120

Standard Length(Order No. VE164X-Dc)

Unit:mm

ORDER NO.	Dc e8	Lc mm	L mm	d h6	CODE NO.
VE164-1.0	1.0	3	50	4	6007-300
VE164-1.5	1.5	5	50	4	6007-301
VE164-2.0	2.0	6	50	4	6007-302
VE164-2.5	2.5	8	50	4	6007-303
VE164-3.0	3.0	8	50	6	6007-304
VE164-4.0	4.0	11	50	6	6007-306
VE164-5.0	5.0	13	50	6	6007-308
VE164-6.0	6.0	16	50	6	6007-310
VE164-8.0	8.0	20	60	8	6007-312
VE164-10.0	10.0	25	72	10	6007-314
VE164-12.0	12.0	30	75	12	6007-316
VE164-14.0	14.0	32	90	16	6007-317
VE164-16.0	16.0	40	100	16	6007-318
VE164-18.0	18.0	40	100	20	6007-319
VE164-20.0	20.0	40	100	20	6007-320

Long Length(Order No. VE165X-Dc)

Unit:mm

ORDER NO.	Dc e8	Lc mm	L mm	d h6	CODE NO.
VE165-3	3	12	70	6	6007-330
VE165-4	4	15	70	6	6007-331
VE165-5	5	20	80	6	6007-332
VE165-6	6	20	80	6	6007-333
VE165-8	8	25	100	8	6007-335
VE165-10	10	30	100	10	6007-337
VE165-12	12	35	110	12	6007-339
VE165-14	14	40	120	16	6007-340
VE165-16	16	50	140	16	6007-341
VE165-20	20	55	160	20	6007-342



Solid Carbide End Mills For <68HRC



Ultra Micro Grain 12% Co Grade
6 Flute

CARBIDE

ISO CODE

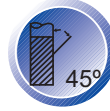

Work Material / Velocity m/min

GR.3 Hardened steels < 48 HRC	GR.4 Hardened steels 48-56 HRC	GR.5 Hardened steels 56-68 HRC	GR.6 Iron
100-200	60-150	20-50	120-300

Standard Length(Order No. VE166X-Dia)

Unit:mm

ORDER NO.	Dia of Mill Tol e8	Shank Dia mm	Flute Length mm	Overall Length mm	CODE NO.
VE166-3	3	6	8	50	6007-240
VE166-4	4	6	11	50	6007-241
VE166-5	5	6	13	50	6007-242
VE166-6	6	6	16	50	6007-243
VE166-8	8	8	20	60	6007-244
VE166-10	10	10	22	72	6007-245
VE166-12	12	12	26	75	6007-246
VE166-16	16	16	38	100	6007-247
VE166-20	20	20	38	100	6007-248

Long Length(Order No. VE167X-Dia)

Unit:mm

ORDER NO.	Dia of Mill Tol e8	Shank Dia mm	Flute Length mm	Overall Length mm	CODE NO.
VE167-6	6	6	26	80	6007-250
VE167-8	8	8	36	100	6007-251
VE167-10	10	10	46	100	6007-252
VE167-12	12	12	56	110	6007-253
VE167-16	16	16	66	140	6007-254
VE167-20	20	20	76	160	6007-255



4 Flute Carbide End Mill Set VE124-B 12PCS/SET In Wooden Box

ORDER NO.VE124-B CODE NO.6007-256

NEW



CARBIDE

SET INCLUDING

VE124-3.0X2PCS
VE124-4.0X2PCS
VE124-6.0X2PCS
VE124-8.0X2PCS
VE124-10.0X2PCS
VE124-12.0X2PCS



4 Flute Carbide End Mill Set VE124-A 18PCS/SET In Wooden Box

ORDER NO.VE124-A CODE NO.6007-257

NEW



CARBIDE

SET INCLUDING

VE124-3.0X3PCS
VE124-4.0X3PCS
VE124-6.0X3PCS
VE124-8.0X3PCS
VE124-10.0X3PCS
VE124-12.0X3PCS



2 Flute Carbide Ball Nose End Mill Set VB222-A 9PCS/SET In Wooden Box

ORDER NO.VB222-A CODE NO.6007-258

NEW



CARBIDE

SET INCLUDING

VB222-4X3PCS
VB222-6X3PCS
VB222-8X3PCS

END MILLS



Work Material / Velocity m/min

GR.1 Non alloyed steels Alloyed Steels	GR.2 Heat resistant steels Stainless steels	GR.3 Hardened steels < 48 HRC	GR.4 Hardened steels 48-56 HRC	GR.6 Iron	GR.7 Titanium	GR.8 Nickel
60-250	35-150	60-120	40-100	60-160	50-180	40-350

CARBIDE

Standard Length(Order No. VEC40-Dia)

Unit:mm

ORDER NO.	Dc h10	Lc mm	L mm	d h6	CODE NO.
VEC40-1.0	1.0	3	50	4	6008-180
VEC40-1.5	1.5	5	50	4	6008-181
VEC40-2.0	2.0	6	50	4	6008-182
VEC40-4.0A	4.0A	11	50	4	6008-185
VEC40-3.0	3.0	8	50	6	6008-186
VEC40-4.0	4.0	11	50	6	6008-187
VEC40-5.0	5.0	13	50	6	6008-188
VEC40-6.0	6.0	16	50	6	6008-189
VEC40-8.0	8.0	20	60	8	6008-191
VEC40-10.0	10.0	25	72	10	6008-193
VEC40-12.0	12.0	30	75	12	6008-194
VEC40-14.0	14.0	40	100	16	6008-195
VEC40-16.0	16.0	45	100	16	6008-196
VEC40-20.0	20.0	50	110	20	6008-197

Long Length(Order No. VED40-Dia)

Unit:mm

ORDER NO.	Dc h10	Lc mm	L mm	d h6	CODE NO.
VED40-4	4	20	80	4	6008-201
VED40-5	5	25	100	6	6008-202
VED40-6	6	30	100	6	6008-203
VED40-8	8	35	100	8	6008-204
VED40-10	10	40	100	10	6008-205
VED40-12	12	45	110	12	6008-206
VED40-16	16	60	150	16	6008-208

Carbide

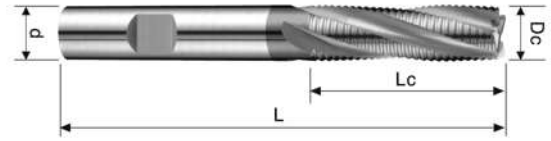
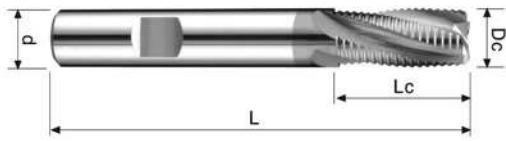
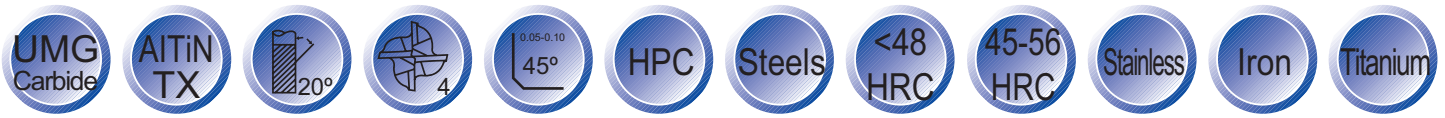

Work Material / Velocity m/min

GR.1 Non alloyed steels Alloyed Steels	GR.2 Heat resistant steels Stainless steels	GR.3 Hardened steels < 48 HRC	GR.4 Hardened steels 48-56 HRC	GR.6 Iron	GR.7 Titanium	GR.8 Nickel
100-180	40-80	80-140	60-100	100-180	20-50	30-50

※ 3 FLUTE ORDER NO.
VFF08-6, VFF08-8
VFF09-6, VFF09-8

Standard Length(Order No. VFF08-Dia)

Unit:mm

ORDER NO.	Dc h10	Lc mm	L mm	d h5	CODE NO.
VFF08-6	6	13	57	6	6008-240
VFF08-8	8	19	63	8	6008-241
VFF08-10	10	22	72	10	6008-242
VFF08-12	12	26	83	12	6008-243
VFF08-14	14	26	83	14	6008-244
VFF08-16	16	32	92	16	6008-245
VFF08-18	18	32	92	18	6008-246
VFF08-20	20	38	104	20	6008-247

Long Length(Order No. VFF09-Dia)

Unit:mm

ORDER NO.	Dc h10	Lc mm	L mm	d h5	CODE NO.
VFF09-6	6	19	63	6	6008-260
VFF09-8	8	28	72	8	6008-261
VFF09-10	10	34	84	10	6008-262
VFF09-12	12	40	97	12	6008-263
VFF09-20	20	56	122	20	6008-265



Solid Carbide End Mills For <48HRC



VERTEX®

Micro Grain 10% Co Grade

2 Flute

ISO CODE

CARBIDE

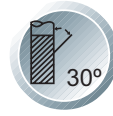

Work Material / Velocity m/min

ORDER NO.	GR.1 Non alloyed steels Alloyed Steels	GR.2 Heat resistant steels Stainless steels	GR.3 Hardened steels < 48 HRC	GR.6 Iron	GR.7 Titanium	GR.8 Nickel	GR.9 Copper
VB221F	60-250	30-100	60-80	30-150	30-180	40-120	100-450
VB222F							
VB232F	60-180	20-80	40-80	30-130	30-120	40-100	100-300



VB242F

Stub Length(Order No. VB221F-Dia)

Unit:mm

ORDER NO.	Dia of Mill Tol e8	Shank Dia mm	Flute Length mm	Overall Length mm	CODE NO.
VB221-1	1.0x0.50R	3	2.5	38	6007-160
VB221-1.5	1.5x0.75R	3	4.0	38	6007-161
VB221-2	2.0x1.00R	3	5.0	38	6007-162
VB221-2.5	2.5x1.25R	3	6.0	38	6007-163
VB221-3	3.0x1.50R	3	6.0	38	6007-164
VB221-3.5	3.5x1.75R	4	8.0	50	6007-165
VB221-4	4.0x2.00R	4	8.0	50	6007-166
VB221-4.5	4.5x2.25R	5	10.0	50	6007-167
VB221-5	5.0x2.50R	5	10.0	50	6007-168
VB221-5.5	5.5x2.75R	6	12.0	50	6007-169
VB221-6	6.0x3.00R	6	12.0	50	6007-170

Standard Length(Order No. VB222F-Dia)

Unit:mm

ORDER NO.	Dia of Mill Tol e8	Shank Dia mm	Flute Length mm	Overall Length mm	CODE NO.
VB222-1	1.00x0.50R	4	2.5	50	6007-180
VB222-1.5	1.50x0.75R	4	4	50	6007-181
VB222-2	2.00x1.00R	4	5	50	6007-182
VB222-2.5	2.50x1.25R	4	6	50	6007-183
VB222-3	3.00x1.50R	6	6	50	6007-184
VB222-4	4.00x2.00R	6	8	50	6007-186
VB222-5	5.00x2.50R	6	10	50	6007-188
VB222-6	6.00x3.00R	6	12	50	6007-190
VB222-7	7.00x3.50R	8	14	60	6007-191
VB222-8	8.00x4.00R	8	14	60	6007-192
VB222-9	9.00x4.50R	10	18	72	6007-193
VB222-10	10.00x5.00R	10	18	72	6007-194
VB222-12	12.00x6.00R	12	22	75	6007-196
VB222-14	14.00x7.00R	16	26	100	6007-197
VB222-16	16.00x8.00R	16	30	100	6007-198
VB222-20	20.00x10.0R	20	38	100	6007-200

Long Length(Order No. VB232F-Dia)

Unit:mm

ORDER NO.	Dia of Mill Tol e8	Shank Dia mm	Flute Length mm	Overall Length mm	CODE NO.
VB232-3	3.0x1.50R	6	6	70	6007-210
VB232-4	4.0x2.00R	6	8	70	6007-211
VB232-5	5.0x2.50R	6	10	80	6007-212
VB232-6	6.0x3.00R	6	12	80	6007-213
VB232-8	8.0x4.00R	8	14	100	6007-215
VB232-10	10.0x5.00R	10	18	100	6007-217
VB232-12	12.0x6.00R	12	22	110	6007-219
VB232-14	14.0x7.00R	16	26	120	6007-220
VB232-16	16.0x8.00R	16	30	140	6007-221
VB232-20	20.0x10.0R	20	38	160	6007-222

Extra Long Length(Order No. VB242F-Dia)

Unit:mm

ORDER NO.	Dia of Mill Tol e8	Shank Dia mm	Flute Length mm	Overall Length mm	CODE NO.
VB242-3	3.0x1.50R	6	9	75	6007-230
VB242-4	4.0x2.00R	6	12	75	6007-231
VB242-5	5.0x2.50R	6	16	100	6007-232
VB242-6	6.0x3.00R	6	20	100	6007-233
VB242-8	8.0x4.00R	8	25	150	6007-234
VB242-10	10.0x5.00R	10	30	150	6007-235
VB242-12	12.0x6.00R	12	35	180	6007-236
VB242-16	16.0x8.00R	16	40	210	6007-237
VB242-20	20.0x10.0R	20	50	210	6007-238



Ball Nose End Mills <56HRC



CARBIDE

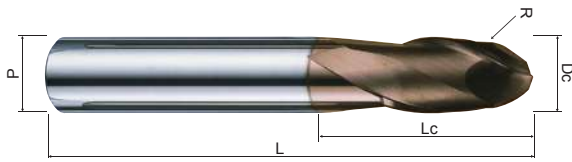

Work Material / Velocity m/min

ORDER NO.	GR.1 Non alloyed steels Alloyed Steels	GR.3 Hardened steels < 48 HRC	GR.4 Hardened steels 48-56 HRC	GR.6 Iron	GR.7 Titanium	GR.8 Nickel
VB262X	80-350	60-200	40-150	50-250	30-180	40-120
VB263X	80-250	60-160	40-120	50-200	30-150	40-100

Standard Length(Order No. VB262X-Dc)

Unit:mm

ORDER NO.	Dc e8	R ±0.01	LC mm	L mm	d h6	CODE NO.
VB262-1.0	1.0	0.5R	2	50	4	6007-350
VB262-1.5	1.5	0.75R	3	50	4	6007-351
VB262-2.0	2.0	1.0R	4	50	4	6007-352
VB262-2.5	2.5	1.25R	5	50	4	6007-353
VB262-3.0	3.0	1.5R	6	50	6	6007-354
VB262-4.0	4.0	2.0R	8	50	6	6007-355
VB262-5.0	5.0	2.5R	10	50	6	6007-356
VB262-6.0	6.0	3.0R	12	50	6	6007-357
VB262-8.0	8.0	4.0R	14	60	8	6007-359
VB262-10.0	10.0	5.0R	18	72	10	6007-361
VB262-12.0	12.0	6.0R	22	75	12	6007-362
VB262-14.0	14.0	7.0R	26	100	16	6007-363
VB262-16.0	16.0	8.0R	30	100	16	6007-364
VB262-20.0	20.0	10.0R	38	100	20	6007-365

Long Length(Order No. VB263X-Dc)

Unit:mm

ORDER NO.	Dc e8	R ±0.01	LC mm	L mm	d h6	CODE NO.
VB263-3	3	1.5R	8	70	6	6007-374
VB263-4	4	2.0R	8	70	6	6007-375
VB263-5	5	2.5R	10	80	6	6007-376
VB263-6	6	3.0R	12	80	6	6007-377
VB263-8	8	4.0R	14	100	8	6007-379
VB263-10	10	5.0R	18	100	10	6007-381
VB263-12	12	6.0R	22	110	12	6007-382
VB263-14	14	7.0R	26	120	16	6007-383
VB263-16	16	8.0R	30	140	16	6007-384
VB263-20	20	10.0R	38	160	20	6007-385



Ball Nose End Mills Carbide



Long Length(Order No. VBB61-Dia)

Unit:mm



Work Material / Velocity m/min

GR.3 Hardened steels < 48 HRC	GR.4 Hardened steels 48-56 HRC	GR.5 Hardened steels 56-68 HRC	GR.6 Iron
120-350	100-210	30-120	80-350

ORDER NO.	Dc h10	R ±0.01	Lc mm	L mm	d h6	L1 mm	CODE NO.
VBB61-1.0	1.0	0.50R	1.0	50	4	2	6008-220
VBB61-1.5	1.5	0.75R	1.5	50	4	3	6008-221
VBB61-2.0	2.0	1.00R	2.0	60	6	4	6008-222
VBB61-3.0	3.0	1.50R	3.0	70	6	6	6008-223
VBB61-4.0	4.0	2.00R	4.0	70	6	8	6008-224
VBB61-5.0	5.0	2.50R	5.0	80	6	10	6008-225
VBB61-6.0	6.0	3.00R	6.0	80	6	12	6008-226
VBB61-8.0	8.0	4.00R	8.0	100	8	16	6008-227
VBB61-10.0	10.0	5.00R	10.0	100	10	20	6008-228
VBB61-12.0	12.0	6.00R	12.0	110	12	24	6008-229



Solid Carbide NC/CNC Spot Drills



Micro Grain 10% Co Grade

CARBIDE



Work Material / Velocity m/min

GR.1 Non alloyed steels Alloyed Steels	GR.2 Heat resistant steels Stainless steels	GR.3 Hardened steels < 48 HRC	GR.4 Hardened steels 48-56 HRC	GR.6 Iron
30-80	20-60	15-25	10-20	40-100
GR.7 Titanium	GR.8 Nickel	GR.9 Copper	GR.10 Aluminium	
20-40	15-40	60-300	80-400	

CUTTING TIP WELD TYPE
FOR VD903,VD904:
FROM Ø3~Ø5 STAY THE SAME.
FROM Ø6~Ø20 SUPPLY IN TIP WELD TYPE.

Standard Length 90° Angle(Order No. VD903-Dia)

Unit:mm

ORDER NO.	Dia of Mill Tol e8	Shank Dia mm	Flute Length mm	Overall Length mm	CODE NO.
VD903-3	3	3	10	38	6007-260
VD903-4	4	4	12	50	6007-261
VD903-5	5	5	15	50	6007-262
VD903-6	6	6	20	60	6007-263
VD903-8	8	8	25	60	6007-264
VD903-10	10	10	25	72	6007-265
VD903-12	12	12	30	75	6007-266
VD903-16	16	16	35	100	6007-267
VD903-20	20	20	40	100	6007-268

Standard Length 120° Angle(Order No. VD913-Dia)

Unit:mm

ORDER NO.	Dia of Mill Tol e8	Shank Dia mm	Flute Length mm	Overall Length mm	CODE NO.
VD913-3	3	3	10	38	6007-270
VD913-4	4	4	12	50	6007-271
VD913-5	5	5	15	50	6007-272
VD913-6	6	6	20	60	6007-273
VD913-8	8	8	25	60	6007-274
VD913-10	10	10	25	72	6007-275
VD913-12	12	12	30	75	6007-276
VD913-16	16	16	35	100	6007-277
VD913-20	20	20	40	100	6007-278

Long Length 90° Angle(Order No. VD904-Dia)

Unit:mm

ORDER NO.	Dia of Mill Tol e8	Shank Dia mm	Flute Length mm	Overall Length mm	CODE NO.
VD904-6	6	6	20	100	6007-280
VD904-8	8	8	25	125	6007-281
VD904-10	10	10	25	150	6007-282
VD904-12	12	12	30	150	6007-283
VD904-16	16	16	35	150	6007-284
VD904-20	20	20	40	150	6007-285

Long Length 120° Angle(Order No. VD914-Dia)

Unit:mm

ORDER NO.	Dia of Mill Tol e8	Shank Dia mm	Flute Length mm	Overall Length mm	CODE NO.
VD914-6	6	6	20	100	6007-290
VD914-8	8	8	25	125	6007-291
VD914-10	10	10	25	150	6007-292
VD914-12	12	12	30	150	6007-293
VD914-16	16	16	35	150	6007-294
VD914-20	20	20	40	150	6007-295

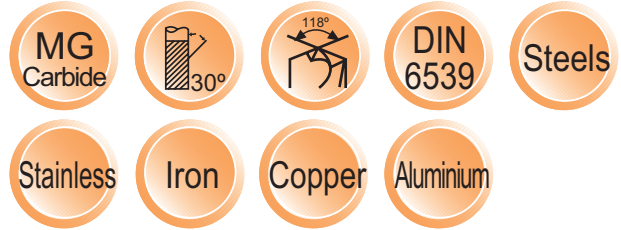

Straight Shank(Order No. VDD12-Dia)

Unit:mm

ORDER NO.	Dc h7	Lc mm	L mm	d mm	CODE NO.
VDD12-1.0	1.0	6	26	1.0	6008-280
VDD12-1.1	1.1	7	28	1.1	6008-281
VDD12-1.2	1.2	8	30	1.2	6008-282
VDD12-1.3	1.3	8	30	1.3	6008-283
VDD12-1.4	1.4	9	32	1.4	6008-284
VDD12-1.5	1.5	9	32	1.5	6008-285
VDD12-1.6	1.6	10	34	1.6	6008-286
VDD12-1.7	1.7	10	34	1.7	6008-287
VDD12-1.8	1.8	11	36	1.8	6008-288
VDD12-1.9	1.9	11	36	1.9	6008-289
VDD12-2.0	2.0	12	38	2.0	6008-290
VDD12-2.1	2.1	12	38	2.1	6008-291
VDD12-2.2	2.2	13	40	2.2	6008-292
VDD12-2.3	2.3	13	40	2.3	6008-293
VDD12-2.4	2.4	14	43	2.4	6008-294
VDD12-2.5	2.5	14	43	2.5	6008-295
VDD12-2.6	2.6	14	43	2.6	6008-296
VDD12-2.7	2.7	16	46	2.7	6008-297
VDD12-2.8	2.8	16	46	2.8	6008-298
VDD12-2.9	2.9	16	46	2.9	6008-299
VDD12-3.0	3.0	16	46	3.0	6008-300
VDD12-3.1	3.1	18	49	3.1	6008-301
VDD12-3.2	3.2	18	49	3.2	6008-302
VDD12-3.3	3.3	18	49	3.3	6008-303
VDD12-3.4	3.4	20	52	3.4	6008-304
VDD12-3.5	3.5	20	52	3.5	6008-305
VDD12-3.6	3.6	20	52	3.6	6008-306
VDD12-3.7	3.7	20	52	3.7	6008-307
VDD12-3.8	3.8	22	55	3.8	6008-308
VDD12-3.9	3.9	22	55	3.9	6008-309
VDD12-4.0	4.0	22	55	4.0	6008-310
VDD12-4.1	4.1	22	55	4.1	6008-311
VDD12-4.2	4.2	22	55	4.2	6008-312
VDD12-4.3	4.3	24	58	4.3	6008-313
VDD12-4.4	4.4	24	58	4.4	6008-314
VDD12-4.5	4.5	24	58	4.5	6008-315
VDD12-4.6	4.6	24	58	4.6	6008-316
VDD12-4.7	4.7	24	58	4.7	6008-317
VDD12-4.8	4.8	26	62	4.8	6008-318
VDD12-4.9	4.9	26	62	4.9	6008-319
VDD12-5.0	5.0	26	62	5.0	6008-320
VDD12-5.1	5.1	26	62	5.1	6008-321
VDD12-5.2	5.2	26	62	5.2	6008-322
VDD12-5.3	5.3	26	62	5.3	6008-323
VDD12-5.4	5.4	28	66	5.4	6008-324
VDD12-5.5	5.5	28	66	5.5	6008-325
VDD12-5.6	5.6	28	66	5.6	6008-326
VDD12-5.7	5.7	28	66	5.7	6008-327
VDD12-5.8	5.8	28	66	5.8	6008-328
VDD12-5.9	5.9	28	66	5.9	6008-329

Work Material / Velocity m/min

GR.1 Non alloyed steels Alloyed Steels	GR.6 Iron	GR.9 Copper	GR.10 Aluminium	GR.11 Plastics
50-80	70-100	100-180	100-250	80-200

ORDER NO.	Dc h7	Lc mm	L mm	d mm	CODE NO.
VDD12-6.0	6.0	28	66	6.0	6008-330
VDD12-6.1	6.1	31	70	6.1	6008-331
VDD12-6.2	6.2	31	70	6.2	6008-332
VDD12-6.3	6.3	31	70	6.3	6008-333
VDD12-6.4	6.4	31	70	6.4	6008-334
VDD12-6.5	6.5	31	70	6.5	6008-335
VDD12-6.6	6.6	31	70	6.6	6008-336
VDD12-6.7	6.7	31	70	6.7	6008-337
VDD12-6.8	6.8	34	74	6.8	6008-338
VDD12-6.9	6.9	34	74	6.9	6008-339
VDD12-7.0	7.0	34	74	7.0	6008-340
VDD12-7.1	7.1	34	74	7.1	6008-341
VDD12-7.2	7.2	34	74	7.2	6008-342
VDD12-7.3	7.3	34	74	7.3	6008-343
VDD12-7.4	7.4	34	74	7.4	6008-344
VDD12-7.5	7.5	34	74	7.5	6008-345
VDD12-7.6	7.6	37	79	7.6	6008-346
VDD12-7.7	7.7	37	79	7.7	6008-347
VDD12-7.8	7.8	37	79	7.8	6008-348
VDD12-7.9	7.9	37	79	7.9	6008-349
VDD12-8.0	8.0	37	79	8.0	6008-350
VDD12-8.1	8.1	37	79	8.1	6008-351
VDD12-8.2	8.2	37	79	8.2	6008-352
VDD12-8.3	8.3	37	79	8.3	6008-353
VDD12-8.4	8.4	37	79	8.4	6008-354
VDD12-8.5	8.5	37	79	8.5	6008-355
VDD12-8.6	8.6	40	84	8.6	6008-356
VDD12-8.7	8.7	40	84	8.7	6008-357
VDD12-8.8	8.8	40	84	8.8	6008-358
VDD12-8.9	8.9	40	84	8.9	6008-359
VDD12-9.0	9.0	40	84	9.0	6008-360
VDD12-9.1	9.1	40	84	9.1	6008-361
VDD12-9.2	9.2	40	84	9.2	6008-362
VDD12-9.3	9.3	40	84	9.3	6008-363
VDD12-9.4	9.4	40	84	9.4	6008-364
VDD12-9.5	9.5	40	84	9.5	6008-365
VDD12-9.6	9.6	43	89	9.6	6008-366
VDD12-9.7	9.7	43	89	9.7	6008-367
VDD12-9.8	9.8	43	89	9.8	6008-368
VDD12-9.9	9.9	43	89	9.9	6008-369
VDD12-10.0	10.0	43	89	10.0	6008-370
VDD12-10.2	10.2	43	89	10.2	6008-371
VDD12-10.5	10.5	43	89	10.5	6008-372
VDD12-11.0	11.0	47	95	11.0	6008-373
VDD12-11.5	11.5	47	95	11.5	6008-374
VDD12-12.0	12.0	51	102	12.0	6008-375
VDD12-13.0	13.0	51	102	13.0	6008-376

TWIST DRILLS

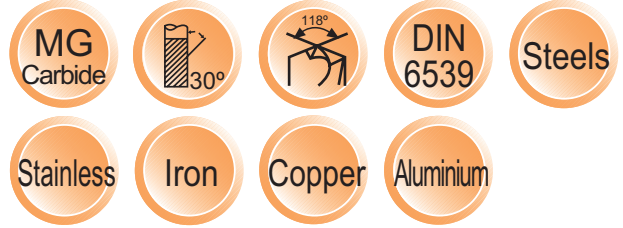

Straight Shank(Order No. VDD13-Dia)

Unit:mm

ORDER NO.	Dc h7	Lc mm	L mm	d mm	CODE NO.
VDD13-1.0	1.0	12	34	1.0	6008-390
VDD13-1.1	1.1	14	36	1.1	6008-391
VDD13-1.2	1.2	16	38	1.2	6008-392
VDD13-1.3	1.3	16	38	1.3	6008-393
VDD13-1.4	1.4	18	40	1.4	6008-394
VDD13-1.5	1.5	18	40	1.5	6008-395
VDD13-1.6	1.6	20	43	1.6	6008-396
VDD13-1.7	1.7	20	43	1.7	6008-397
VDD13-1.8	1.8	22	46	1.8	6008-398
VDD13-1.9	1.9	22	46	1.9	6008-399
VDD13-2.0	2.0	24	49	2.0	6008-400
VDD13-2.1	2.1	24	49	2.1	6008-401
VDD13-2.2	2.2	27	53	2.2	6008-402
VDD13-2.3	2.3	27	53	2.3	6008-403
VDD13-2.4	2.4	30	57	2.4	6008-404
VDD13-2.5	2.5	30	57	2.5	6008-405
VDD13-2.6	2.6	30	57	2.6	6008-406
VDD13-2.7	2.7	33	61	2.7	6008-407
VDD13-2.8	2.8	33	61	2.8	6008-408
VDD13-2.9	2.9	33	61	2.9	6008-409
VDD13-3.0	3.0	33	61	3.0	6008-410
VDD13-3.1	3.1	36	65	3.1	6008-411
VDD13-3.2	3.2	36	65	3.2	6008-412
VDD13-3.3	3.3	36	65	3.3	6008-413
VDD13-3.4	3.4	39	70	3.4	6008-414
VDD13-3.5	3.5	39	70	3.5	6008-415
VDD13-3.6	3.6	39	70	3.6	6008-416
VDD13-3.7	3.7	39	70	3.7	6008-417
VDD13-3.8	3.8	43	75	3.8	6008-418
VDD13-3.9	3.9	43	75	3.9	6008-419
VDD13-4.0	4.0	43	75	4.0	6008-420
VDD13-4.1	4.1	43	75	4.1	6008-421
VDD13-4.2	4.2	43	75	4.2	6008-422
VDD13-4.3	4.3	47	80	4.3	6008-423
VDD13-4.4	4.4	47	80	4.4	6008-424
VDD13-4.5	4.5	47	80	4.5	6008-425
VDD13-4.6	4.6	47	80	4.6	6008-426
VDD13-4.7	4.7	47	80	4.7	6008-427
VDD13-4.8	4.8	52	86	4.8	6008-428
VDD13-4.9	4.9	52	86	4.9	6008-429
VDD13-5.0	5.0	52	86	5.0	6008-430
VDD13-5.1	5.1	52	86	5.1	6008-431
VDD13-5.2	5.2	52	86	5.2	6008-432
VDD13-5.3	5.3	52	86	5.3	6008-433
VDD13-5.4	5.4	57	93	5.4	6008-434
VDD13-5.5	5.5	57	93	5.5	6008-435
VDD13-5.6	5.6	57	93	5.6	6008-436
VDD13-5.7	5.7	57	93	5.7	6008-437
VDD13-5.8	5.8	57	93	5.8	6008-438
VDD13-5.9	5.9	57	93	5.9	6008-439

Work Material / Velocity m/min

GR.1 Non alloyed steels Alloyed Steels	GR.6 Iron	GR.9 Copper	GR.10 Aluminium	GR.11 Plastics
50-80	70-100	100-180	100-250	80-200

ORDER NO.	Dc h7	Lc mm	L mm	d mm	CODE NO.
VDD13-6.0	6.0	57	93	6.0	6008-440
VDD13-6.1	6.1	63	101	6.1	6008-441
VDD13-6.2	6.2	63	101	6.2	6008-442
VDD13-6.3	6.3	63	101	6.3	6008-443
VDD13-6.4	6.4	63	101	6.4	6008-444
VDD13-6.5	6.5	63	101	6.5	6008-445
VDD13-6.6	6.6	63	101	6.6	6008-446
VDD13-6.7	6.7	63	101	6.7	6008-447
VDD13-6.8	6.8	69	109	6.8	6008-448
VDD13-6.9	6.9	69	109	6.9	6008-449
VDD13-7.0	7.0	69	109	7.0	6008-450
VDD13-7.1	7.1	69	109	7.1	6008-451
VDD13-7.2	7.2	69	109	7.2	6008-452
VDD13-7.3	7.3	69	109	7.3	6008-453
VDD13-7.4	7.4	69	109	7.4	6008-454
VDD13-7.5	7.5	69	109	7.5	6008-455
VDD13-7.6	7.6	75	117	7.6	6008-456
VDD13-7.7	7.7	75	117	7.7	6008-457
VDD13-7.8	7.8	75	117	7.8	6008-458
VDD13-7.9	7.9	75	117	7.9	6008-459
VDD13-8.0	8.0	75	117	8.0	6008-460
VDD13-8.1	8.1	75	117	8.1	6008-461
VDD13-8.2	8.2	75	117	8.2	6008-462
VDD13-8.3	8.3	75	117	8.3	6008-463
VDD13-8.4	8.4	75	117	8.4	6008-464
VDD13-8.5	8.5	75	117	8.5	6008-465
VDD13-8.6	8.6	81	125	8.6	6008-466
VDD13-8.7	8.7	81	125	8.7	6008-467
VDD13-8.8	8.8	81	125	8.8	6008-468
VDD13-8.9	8.9	81	125	8.9	6008-469
VDD13-9.0	9.0	81	125	9.0	6008-470
VDD13-9.1	9.1	81	125	9.1	6008-471
VDD13-9.2	9.2	81	125	9.2	6008-472
VDD13-9.3	9.3	81	125	9.3	6008-473
VDD13-9.4	9.4	81	125	9.4	6008-474
VDD13-9.5	9.5	81	125	9.5	6008-475
VDD13-9.6	9.6	87	133	9.6	6008-476
VDD13-9.7	9.7	87	133	9.7	6008-477
VDD13-9.8	9.8	87	133	9.8	6008-478
VDD13-9.9	9.9	87	133	9.9	6008-479
VDD13-10.0	10.0	87	133	10.0	6008-480
VDD13-10.2	10.2	87	133	10.2	6008-481
VDD13-10.5	10.5	87	133	10.5	6008-482
VDD13-11.0	11.0	94	142	11.0	6008-483
VDD13-11.5	11.5	94	142	11.5	6008-484
VDD13-12.0	12.0	101	151	12.0	6008-485
VDD13-13.0	13.0	101	151	13.0	6008-486





Straight Shank (Order No. VDD30-Dia)

Unit:mm

ORDER NO.	Dc h7	Lc mm	L mm	d mm	CODE NO.
VDD30-2.0	2.0	12	38	2.0	6008-500
VDD30-2.1	2.1	12	38	2.1	6008-501
VDD30-2.2	2.2	13	40	2.2	6008-502
VDD30-2.3	2.3	13	40	2.3	6008-503
VDD30-2.4	2.4	14	43	2.4	6008-504
VDD30-2.5	2.5	14	43	2.5	6008-505
VDD30-2.6	2.6	14	43	2.6	6008-506
VDD30-2.7	2.7	16	46	2.7	6008-507
VDD30-2.8	2.8	16	46	2.8	6008-508
VDD30-2.9	2.9	16	46	2.9	6008-509
VDD30-3.0	3.0	16	46	3.0	6008-510
VDD30-3.1	3.1	18	49	3.1	6008-511
VDD30-3.2	3.2	18	49	3.2	6008-512
VDD30-3.3	3.3	18	49	3.3	6008-513
VDD30-3.4	3.4	20	52	3.4	6008-514
VDD30-3.5	3.5	20	52	3.5	6008-515
VDD30-3.6	3.6	20	52	3.6	6008-516
VDD30-3.7	3.7	20	52	3.7	6008-517
VDD30-3.8	3.8	22	55	3.8	6008-518
VDD30-3.9	3.9	22	55	3.9	6008-519
VDD30-4.0	4.0	22	55	4.0	6008-520
VDD30-4.1	4.1	22	55	4.1	6008-521
VDD30-4.2	4.2	22	55	4.2	6008-522
VDD30-4.3	4.3	24	58	4.3	6008-523
VDD30-4.4	4.4	24	58	4.4	6008-524
VDD30-4.5	4.5	24	58	4.5	6008-525
VDD30-4.6	4.6	24	58	4.6	6008-526
VDD30-4.7	4.7	24	58	4.7	6008-527
VDD30-4.8	4.8	26	62	4.8	6008-528
VDD30-4.9	4.9	26	62	4.9	6008-529
VDD30-5.0	5.0	26	62	5.0	6008-530
VDD30-5.1	5.1	26	62	5.1	6008-531
VDD30-5.2	5.2	26	62	5.2	6008-532
VDD30-5.3	5.3	26	62	5.3	6008-533
VDD30-5.4	5.4	28	66	5.4	6008-534
VDD30-5.5	5.5	28	66	5.5	6008-535
VDD30-5.6	5.6	28	66	5.6	6008-536
VDD30-5.7	5.7	28	66	5.7	6008-537
VDD30-5.8	5.8	28	66	5.8	6008-538
VDD30-5.9	5.9	28	66	5.9	6008-539
VDD30-6.0	6.0	28	66	6.0	6008-540
VDD30-6.1	6.1	31	70	6.1	6008-541
VDD30-6.2	6.2	31	70	6.2	6008-542
VDD30-6.3	6.3	31	70	6.3	6008-543
VDD30-6.4	6.4	31	70	6.4	6008-544
VDD30-6.5	6.5	31	70	6.5	6008-545
VDD30-6.6	6.6	31	70	6.6	6008-546
VDD30-6.7	6.7	31	70	6.7	6008-547
VDD30-6.8	6.8	34	74	6.8	6008-548
VDD30-6.9	6.9	34	74	6.9	6008-549

Work Material / Velocity m/min

GR.1 Non alloyed steels <small>Alloyed Steels</small>	GR.2 Heat resistant steels <small>Stainless steels</small>	GR.3 Hardened steels <small>< 48 HRC</small>	GR.4 Hardened steels <small>48-56 HRC</small>	GR.6 Iron
70-100	30-50	20-30	10-20	90-130
GR.7 Titanium	GR.8 Nickel	GR.9 Copper	GR.10 Aluminium	
25-45	20-45	130-230	130-300	

ORDER NO.	Dc h7	Lc mm	L mm	d mm	CODE NO.
VDD30-7.0	7.0	34	74	7.0	6008-550
VDD30-7.1	7.1	34	74	7.1	6008-551
VDD30-7.2	7.2	34	74	7.2	6008-552
VDD30-7.3	7.3	34	74	7.3	6008-553
VDD30-7.4	7.4	34	74	7.4	6008-554
VDD30-7.5	7.5	34	74	7.5	6008-555
VDD30-7.6	7.6	37	79	7.6	6008-556
VDD30-7.7	7.7	37	79	7.7	6008-557
VDD30-7.8	7.8	37	79	7.8	6008-558
VDD30-7.9	7.9	37	79	7.9	6008-559
VDD30-8.0	8.0	37	79	8.0	6008-560
VDD30-8.1	8.1	37	79	8.1	6008-561
VDD30-8.2	8.2	37	79	8.2	6008-562
VDD30-8.3	8.3	37	79	8.3	6008-563
VDD30-8.4	8.4	37	79	8.4	6008-564
VDD30-8.5	8.5	37	79	8.5	6008-565
VDD30-8.6	8.6	40	84	8.6	6008-566
VDD30-8.7	8.7	40	84	8.7	6008-567
VDD30-8.8	8.8	40	84	8.8	6008-568
VDD30-8.9	8.9	40	84	8.9	6008-569
VDD30-9.0	9.0	40	84	9.0	6008-570
VDD30-9.1	9.1	40	84	9.1	6008-571
VDD30-9.2	9.2	40	84	9.2	6008-572
VDD30-9.3	9.3	40	84	9.3	6008-573
VDD30-9.4	9.4	40	84	9.4	6008-574
VDD30-9.5	9.5	40	84	9.5	6008-575
VDD30-9.6	9.6	43	89	9.6	6008-576
VDD30-9.7	9.7	43	89	9.7	6008-577
VDD30-9.8	9.8	43	89	9.8	6008-578
VDD30-9.9	9.9	43	89	9.9	6008-579
VDD30-10.0	10.0	43	89	10.0	6008-580
VDD30-10.2	10.2	43	89	10.2	6008-581
VDD30-10.5	10.5	43	89	10.5	6008-582
VDD30-10.8	10.8	47	95	10.8	6008-583
VDD30-11.0	11.0	47	95	11.0	6008-584
VDD30-11.5	11.5	47	95	11.5	6008-585
VDD30-12.0	12.0	51	102	12.0	6008-586
VDD30-12.5	12.5	51	102	12.5	6008-587
VDD30-13.0	13.0	51	102	13.0	6008-588

PERFORMANCE DRILLS



High Performance Drills

Carbide **VERTEX**[®]

UMG
Carbide

TiAlN
F-TOP

3XD

2

140°

DIN
6537K

Steels

Stainless

<48
HRC

45-56
HRC

Iron

Titanium

Nickel



Stud Length(Order No. VDD31-Dia)

Unit:mm

ORDER NO.	Dc h7	Lc mm	L mm	d h6	Ld mm	d mm	CODE NO.
VDD31-3.0	3.0	20	62	6	36	3.0	6008-600
VDD31-3.1	3.1	20	62	6	36	3.1	6008-601
VDD31-3.2	3.2	20	62	6	36	3.2	6008-602
VDD31-3.3	3.3	20	62	6	36	3.3	6008-603
VDD31-3.4	3.4	20	62	6	36	3.4	6008-604
VDD31-3.5	3.5	20	62	6	36	3.5	6008-605
VDD31-3.6	3.6	20	62	6	36	3.6	6008-606
VDD31-3.7	3.7	20	62	6	36	3.7	6008-607
VDD31-3.8	3.8	24	66	6	36	3.8	6008-608
VDD31-3.9	3.9	24	66	6	36	3.9	6008-609
VDD31-4.0	4.0	24	66	6	36	4.0	6008-610
VDD31-4.1	4.1	24	66	6	36	4.1	6008-611
VDD31-4.2	4.2	24	66	6	36	4.2	6008-612
VDD31-4.3	4.3	24	66	6	36	4.3	6008-613
VDD31-4.4	4.4	24	66	6	36	4.4	6008-614
VDD31-4.5	4.5	24	66	6	36	4.5	6008-615
VDD31-4.6	4.6	24	66	6	36	4.6	6008-616
VDD31-4.7	4.7	24	66	6	36	4.7	6008-617
VDD31-4.8	4.8	28	66	6	36	4.8	6008-618
VDD31-4.9	4.9	28	66	6	36	4.9	6008-619
VDD31-5.0	5.0	28	66	6	36	5.0	6008-620
VDD31-5.1	5.1	28	66	6	36	5.1	6008-621
VDD31-5.2	5.2	28	66	6	36	5.2	6008-622
VDD31-5.3	5.3	28	66	6	36	5.3	6008-623
VDD31-5.4	5.4	28	66	6	36	5.4	6008-624
VDD31-5.5	5.5	28	66	6	36	5.5	6008-625
VDD31-5.6	5.6	28	66	6	36	5.6	6008-626
VDD31-5.7	5.7	28	66	6	36	5.7	6008-627
VDD31-5.8	5.8	28	66	6	36	5.8	6008-628
VDD31-5.9	5.9	28	66	6	36	5.9	6008-629
VDD31-6.0	6.0	28	66	6	36	6.0	6008-630
VDD31-6.1	6.1	34	79	8	36	6.1	6008-631
VDD31-6.2	6.2	34	79	8	36	6.2	6008-632
VDD31-6.3	6.3	34	79	8	36	6.3	6008-633
VDD31-6.4	6.4	34	79	8	36	6.4	6008-634
VDD31-6.5	6.5	34	79	8	36	6.5	6008-635
VDD31-6.6	6.6	34	79	8	36	6.6	6008-636
VDD31-6.7	6.7	34	79	8	36	6.7	6008-637
VDD31-6.8	6.8	34	79	8	36	6.8	6008-638
VDD31-6.9	6.9	34	79	8	36	6.9	6008-639
VDD31-7.0	7.0	34	79	8	36	7.0	6008-640
VDD31-7.1	7.1	41	79	8	36	7.1	6008-641
VDD31-7.2	7.2	41	79	8	36	7.2	6008-642
VDD31-7.3	7.3	41	79	8	36	7.3	6008-643
VDD31-7.4	7.4	41	79	8	36	7.4	6008-644
VDD31-7.5	7.5	41	79	8	36	7.5	6008-645
VDD31-7.6	7.6	41	79	8	36	7.6	6008-646
VDD31-7.7	7.7	41	79	8	36	7.7	6008-647
VDD31-7.8	7.8	41	79	8	36	7.8	6008-648
VDD31-7.9	7.9	41	79	8	36	7.9	6008-649

Work Material / Velocity m/min

GR.1 Non alloyed steels Alloyed Steels	GR.2 Heat resistant steels Stainless steels	GR.3 Hardened steels < 48 HRC	GR.4 Hardened steels 48-56 HRC	GR.6 Iron
80-180	45-60	40-60	15-35	90-130
GR.7 Titanium	GR.8 Nickel	GR.9 Copper	GR.10 Aluminium	
35-45	30-45	130-230	130-300	

ORDER NO.	Dc h7	Lc mm	L mm	d h6	Ld mm	d mm	CODE NO.
VDD31-8.0	8.0	41	79	8	36	8.0	6008-650
VDD31-8.1	8.1	47	89	10	40	8.1	6008-651
VDD31-8.2	8.2	47	89	10	40	8.2	6008-652
VDD31-8.3	8.3	47	89	10	40	8.3	6008-653
VDD31-8.4	8.4	47	89	10	40	8.4	6008-654
VDD31-8.5	8.5	47	89	10	40	8.5	6008-655
VDD31-8.6	8.6	47	89	10	40	8.6	6008-656
VDD31-8.7	8.7	47	89	10	40	8.7	6008-657
VDD31-8.8	8.8	47	89	10	40	8.8	6008-658
VDD31-8.9	8.9	47	89	10	40	8.9	6008-659
VDD31-9.0	9.0	47	89	10	40	9.0	6008-660
VDD31-9.1	9.1	47	89	10	40	9.1	6008-661
VDD31-9.2	9.2	47	89	10	40	9.2	6008-662
VDD31-9.3	9.3	47	89	10	40	9.3	6008-663
VDD31-9.4	9.4	47	89	10	40	9.4	6008-664
VDD31-9.5	9.5	47	89	10	40	9.5	6008-665
VDD31-9.6	9.6	47	89	10	40	9.6	6008-666
VDD31-9.7	9.7	47	89	10	40	9.7	6008-667
VDD31-9.8	9.8	47	89	10	40	9.8	6008-668
VDD31-9.9	9.9	47	89	10	40	9.9	6008-669
VDD31-10.0	10.0	47	89	10	40	10.0	6008-670
VDD31-10.2	10.2	55	102	12	45	10.2	6008-671
VDD31-10.5	10.5	55	102	12	45	10.5	6008-672
VDD31-10.8	10.8	55	102	12	45	10.8	6008-673
VDD31-11.0	11.0	55	102	12	45	11.0	6008-674
VDD31-11.5	11.5	55	102	12	45	11.5	6008-675
VDD31-12.0	12.0	55	102	12	45	12.0	6008-676
VDD31-12.5	12.5	60	107	14	45	12.5	6008-677
VDD31-13.0	13.0	60	107	14	45	13.0	6008-678
VDD31-13.5	13.5	60	107	14	45	13.5	6008-679
VDD31-14.0	14.0	60	107	14	45	14.0	6008-680
VDD31-14.5	14.5	65	115	16	48	14.5	6008-681
VDD31-15.0	15.0	65	115	16	48	15.0	6008-682
VDD31-15.5	15.5	65	115	16	48	15.5	6008-683
VDD31-16.0	16.0	65	115	16	48	16.0	6008-684
VDD31-16.5	16.5	73	123	18	48	16.5	6008-685
VDD31-17.0	17.0	73	123	18	48	17.0	6008-686
VDD31-17.5	17.5	73	123	18	48	17.5	6008-687
VDD31-18.0	18.0	73	123	18	48	18.0	6008-688
VDD31-18.5	18.5	79	131	20	50	18.5	6008-689
VDD31-19.0	19.0	79	131	20	50	19.0	6008-690
VDD31-19.5	19.5	79	131	20	50	19.5	6008-691
VDD31-20.0	20.0	79	131	20	50	20.0	6008-692





Standard Length(Order No. VDD32-Dia)

Unit:mm

ORDER NO.	Dc h7	Lc mm	L mm	d h6	Ld mm	d mm	CODE NO.
VDD32-3.0	3.0	28	66	6	36	3.0	6008-700
VDD32-3.1	3.1	28	66	6	36	3.1	6008-701
VDD32-3.2	3.2	28	66	6	36	3.2	6008-702
VDD32-3.3	3.3	28	66	6	36	3.3	6008-703
VDD32-3.4	3.4	28	66	6	36	3.4	6008-704
VDD32-3.5	3.5	28	66	6	36	3.5	6008-705
VDD32-3.6	3.6	28	66	6	36	3.6	6008-706
VDD32-3.7	3.7	28	66	6	36	3.7	6008-707
VDD32-3.8	3.8	36	74	6	36	3.8	6008-708
VDD32-3.9	3.9	36	74	6	36	3.9	6008-709
VDD32-4.0	4.0	36	74	6	36	4.0	6008-710
VDD32-4.1	4.1	36	74	6	36	4.1	6008-711
VDD32-4.2	4.2	36	74	6	36	4.2	6008-712
VDD32-4.3	4.3	36	74	6	36	4.3	6008-713
VDD32-4.4	4.4	36	74	6	36	4.4	6008-714
VDD32-4.5	4.5	36	74	6	36	4.5	6008-715
VDD32-4.6	4.6	36	74	6	36	4.6	6008-716
VDD32-4.7	4.7	36	74	6	36	4.7	6008-717
VDD32-4.8	4.8	44	82	6	36	4.8	6008-718
VDD32-4.9	4.9	44	82	6	36	4.9	6008-719
VDD32-5.0	5.0	44	82	6	36	5.0	6008-720
VDD32-5.1	5.1	44	82	6	36	5.1	6008-721
VDD32-5.2	5.2	44	82	6	36	5.2	6008-722
VDD32-5.3	5.3	44	82	6	36	5.3	6008-723
VDD32-5.4	5.4	44	82	6	36	5.4	6008-724
VDD32-5.5	5.5	44	82	6	36	5.5	6008-725
VDD32-5.6	5.6	44	82	6	36	5.6	6008-726
VDD32-5.7	5.7	44	82	6	36	5.7	6008-727
VDD32-5.8	5.8	44	82	6	36	5.8	6008-728
VDD32-5.9	5.9	44	82	6	36	5.9	6008-729
VDD32-6.0	6.0	44	82	6	36	6.0	6008-730
VDD32-6.1	6.1	53	91	8	36	6.1	6008-731
VDD32-6.2	6.2	53	91	8	36	6.2	6008-732
VDD32-6.3	6.3	53	91	8	36	6.3	6008-733
VDD32-6.4	6.4	53	91	8	36	6.4	6008-734
VDD32-6.5	6.5	53	91	8	36	6.5	6008-735
VDD32-6.6	6.6	53	91	8	36	6.6	6008-736
VDD32-6.7	6.7	53	91	8	36	6.7	6008-737
VDD32-6.8	6.8	53	91	8	36	6.8	6008-738
VDD32-6.9	6.9	53	91	8	36	6.9	6008-739
VDD32-7.0	7.0	53	91	8	36	7.0	6008-740
VDD32-7.1	7.1	53	91	8	36	7.1	6008-741
VDD32-7.2	7.2	53	91	8	36	7.2	6008-742
VDD32-7.3	7.3	53	91	8	36	7.3	6008-743
VDD32-7.4	7.4	53	91	8	36	7.4	6008-744
VDD32-7.5	7.5	53	91	8	36	7.5	6008-745
VDD32-7.6	7.6	53	91	8	36	7.6	6008-746
VDD32-7.7	7.7	53	91	8	36	7.7	6008-747
VDD32-7.8	7.8	53	91	8	36	7.8	6008-748
VDD32-7.9	7.9	53	91	8	36	7.9	6008-749

Work Material / Velocity m/min

GR.1 Non alloyed steels Alloyed Steels	GR.2 Heat resistant steels Stainless steels	GR.3 Hardened steels < 48 HRC	GR.4 Hardened steels 48-56 HRC	GR.6 Iron
80-180	45-60	40-60	15-35	90-130
GR.7 Titanium	GR.8 Nickel	GR.9 Copper	GR.10 Aluminium	
35-45	30-45	130-230	130-300	

ORDER NO.	Dc h7	Lc mm	L mm	d h6	Ld mm	d mm	CODE NO.
VDD32-8.0	8.0	53	91	8	36	8.0	6008-750
VDD32-8.1	8.1	61	103	10	40	8.1	6008-751
VDD32-8.2	8.2	61	103	10	40	8.2	6008-752
VDD32-8.3	8.3	61	103	10	40	8.3	6008-753
VDD32-8.4	8.4	61	103	10	40	8.4	6008-754
VDD32-8.5	8.5	61	103	10	40	8.5	6008-755
VDD32-8.6	8.6	61	103	10	40	8.6	6008-756
VDD32-8.7	8.7	61	103	10	40	8.7	6008-757
VDD32-8.8	8.8	61	103	10	40	8.8	6008-758
VDD32-8.9	8.9	61	103	10	40	8.9	6008-759
VDD32-9.0	9.0	61	103	10	40	9.0	6008-760
VDD32-9.1	9.1	61	103	10	40	9.1	6008-761
VDD32-9.2	9.2	61	103	10	40	9.2	6008-762
VDD32-9.3	9.3	61	103	10	40	9.3	6008-763
VDD32-9.4	9.4	61	103	10	40	9.4	6008-764
VDD32-9.5	9.5	61	103	10	40	9.5	6008-765
VDD32-9.6	9.6	61	103	10	40	9.6	6008-766
VDD32-9.7	9.7	61	103	10	40	9.7	6008-767
VDD32-9.8	9.8	61	103	10	40	9.8	6008-768
VDD32-9.9	9.9	61	103	10	40	9.9	6008-769
VDD32-10.0	10.0	61	103	10	40	10.0	6008-770
VDD32-10.2	10.2	71	118	12	45	10.2	6008-771
VDD32-10.5	10.5	71	118	12	45	10.5	6008-772
VDD32-10.8	10.8	71	118	12	45	10.8	6008-773
VDD32-11.0	11.0	71	118	12	45	11.0	6008-774
VDD32-11.5	11.5	71	118	12	45	11.5	6008-775
VDD32-12.0	12.0	71	118	12	45	12.0	6008-776
VDD32-12.5	12.5	77	124	14	45	12.5	6008-777
VDD32-13.0	13.0	77	124	14	45	13.0	6008-778
VDD32-13.5	13.5	77	124	14	45	13.5	6008-779
VDD32-14.0	14.0	77	124	14	45	14.0	6008-780
VDD32-14.5	14.5	83	133	16	48	14.5	6008-781
VDD32-15.0	15.0	83	133	16	48	15.0	6008-782
VDD32-15.5	15.5	83	133	16	48	15.5	6008-783
VDD32-16.0	16.0	83	133	16	48	16.0	6008-784
VDD32-16.5	16.5	93	143	18	48	16.5	6008-785
VDD32-17.0	17.0	93	143	18	48	17.0	6008-786
VDD32-17.5	17.5	93	143	18	48	17.5	6008-787
VDD32-18.0	18.0	93	143	18	48	18.0	6008-788
VDD32-18.5	18.5	101	153	20	50	18.5	6008-789
VDD32-19.0	19.0	101	153	20	50	19.0	6008-790
VDD32-19.5	19.5	101	153	20	50	19.5	6008-791
VDD32-20.0	20.0	101	153	20	50	20.0	6008-792



Combined Drill And Countersink



VERTEX®

Carbide



Standard Length(Order No. VDT08-Dia)

Unit:mm

ORDER NO.	Dc h7	Lc mm	L mm	d h6	CODE NO.
VDT08-0.50	0.50	0.8	38	3	6008-800
VDT08-0.80	0.80	1.1	38	3	6008-801
VDT08-1.00	1.00	1.3	38	3	6008-802
VDT08-1.25	1.25	1.6	38	3	6008-803
VDT08-1.60	1.60	2.0	38	4	6008-804
VDT08-2.00	2.00	2.5	50	5	6008-805
VDT08-2.50	2.50	3.1	50	6	6008-806
VDT08-3.15	3.15	3.9	63	8	6008-807
VDT08-4.00	4.00	5.0	66	10	6008-808
VDT08-5.00	5.00	6.3	73	12	6008-809

Work Material / Velocity m/min

GR.1 Non alloyed steels Alloyed Steels	GR.2 Heat resistant steels Stainless steels	GR.3 Hardened steels < 48 HRC	GR.4 Hardened steels 48-56 HRC	GR.6 Iron
30-80	20-60	15-25	10-20	40-100
GR.7 Titanium	GR.8 Nickel	GR.9 Copper	GR.10 Aluminium	
20-40	15-40	60-300	80-400	



Combined Drill And Countersink

Material: 6542A **HSS**



Work Material / Velocity m/min

GR.1 Non alloyed steels Alloyed Steels	GR.2 Heat resistant steels Stainless steels	GR.3 Hardened steels < 48 HRC	GR.4 Hardened steels 48-56 HRC	GR.6 Iron
30-80	20-60	15-25	10-20	40-100
GR.7 Titanium	GR.8 Nickel	GR.9 Copper	GR.10 Aluminium	
20-40	15-40	60-300	80-400	

ORDER NO.	Dc	d	L	CODE NO.
VDTHS-1.6	1.6	5	40	6008-850
VDTHS-2.0	2	5	40	6008-851
VDTHS-2.5	2.5	6	45	6008-852
VDTHS-3.15	3.15	8	50	6008-853
VDTHS-4.0	4	10	56	6008-854
VDTHS-5.0	5	12	63	6008-855
VDTHS-6.0	6	14	71	6008-856



Machine Reamers

In Steps of 0.5mm



Carbide

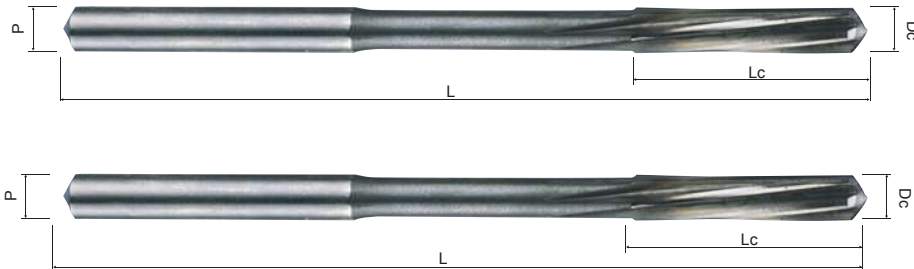
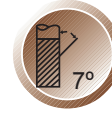

Work Material / Velocity m/min

GR.1 Non alloyed steels Alloyed Steels	GR.2 Heat resistant steels Stainless steels	GR.3 Hardened steels < 48 HRC	GR.4 Hardened steels 48-56 HRC	GR.6 Iron	GR.7 Titanium	GR.8 Nickel	GR.9 Copper	GR.10 Aluminium
7-25	7-15	5-10	5-10	10-22	10-25	5-20	30-45	20-50

- ※ 2.0-9.0 VHM Solid Carbide
- ※ 10.0-20.0 HM Carbide Tipped

Straight Shank(Order No. VR301-Dc)

Unit:mm

ORDER NO.	Dc H7	Lc mm	L mm	d mm	Z teeth	CODE NO.
VR301-2.0	2.0	11	49	2.0	4	6007-390
VR301-2.5	2.5	14	57	2.5	4	6007-391
VR301-3.0	3.0	15	61	3.0	4	6007-392
VR301-3.5	3.5	18	70	3.5	4	6007-393
VR301-4.0	4.0	19	75	4.0	4	6007-394
VR301-4.5	4.5	21	80	4.5	4	6007-395
VR301-5.0	5.0	23	86	5.0	6	6007-396
VR301-5.5	5.5	26	93	5.5	6	6007-397
VR301-6.0	6.0	26	93	6.0	6	6007-398
VR301-7.0	7.0	31	109	7.0	6	6007-400
VR301-8.0	8.0	33	117	8.0	6	6007-402
VR301-9.0	9.0	36	125	9.0	6	6007-404
VR301-10.0	10.0	38	133	10.0	6	6007-406

※ 2.0-9.0 VHM Solid Carbide ※ 10.0-20.0 HM Carbide Tipped

ORDER NO.	Dc H7	Lc mm	L mm	d mm	Z teeth	CODE NO.
VR301-11.0	11.0	41	142	10.0	6	6007-408
VR301-12.0	12.0	44	151	10.0	6	6007-410
VR301-13.0	13.0	44	151	10.0	6	6007-412
VR301-14.0	14.0	47	160	12.5	6	6007-414
VR301-15.0	15.0	50	162	12.5	6	6007-416
VR301-16.0	16.0	52	170	12.5	6	6007-418
VR301-17.0	17.0	54	175	14.0	6	6007-419
VR301-18.0	18.0	56	182	14.0	6	6007-420
VR301-19.0	19.0	58	189	16.0	6	6007-421
VR301-20.0	20.0	60	195	16.0	6	6007-422

MACHINE REAMERS



Machine Reamers Carbide Tipped

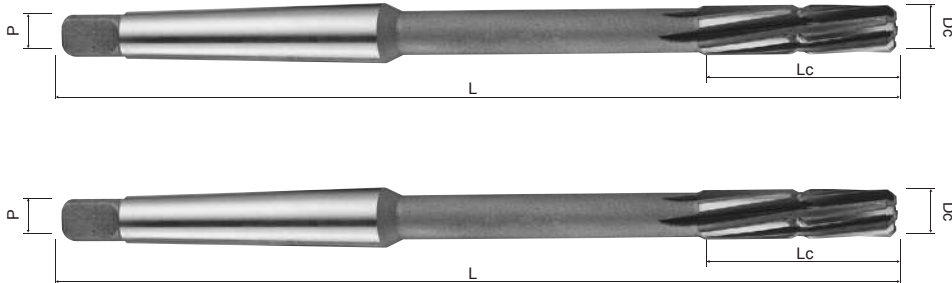
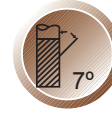

Work Material / Velocity m/min

GR.1 Non alloyed steels Alloyed Steels	GR.2 Heat resistant steels Stainless steels	GR.3 Hardened steels < 48 HRC	GR.4 Hardened steels 48-56 HRC	GR.6 Iron	GR.7 Titanium	GR.8 Nickel	GR.9 Copper	GR.10 Aluminium
7-25	7-15	5-10	5-10	10-22	10-25	5-20	30-45	20-50



Taper Shank(Order No. VR303-Dc)

Unit:mm

ORDER NO.	Dc H7	Lc mm	L mm	d MT-#	Z teeth	CODE NO.
VR303-10.0	10.0	38	168	MT-1	6	6007-430
VR303-11.0	11.0	41	175	MT-1	6	6007-431
VR303-12.0	12.0	44	182	MT-1	6	6007-432
VR303-13.0	13.0	44	182	MT-1	6	6007-433
VR303-14.0	14.0	47	189	MT-1	6	6007-434
VR303-15.0	15.0	50	204	MT-2	6	6007-435
VR303-16.0	16.0	52	210	MT-2	6	6007-436
VR303-17.0	17.0	54	214	MT-2	6	6007-437
VR303-18.0	18.0	56	219	MT-2	6	6007-438
VR303-19.0	19.0	58	223	MT-2	6	6007-439
VR303-20.0	20.0	60	228	MT-2	6	6007-440
VR303-22.0	22.0	64	237	MT-2	6	6007-441
VR303-24.0	24.0	68	268	MT-3	8	6007-442

ORDER NO.	Dc H7	Lc mm	L mm	d mt	Z teeth	CODE NO.
VR303-25.0	25.0	68	268	3	8	6007-443
VR303-26.0	26.0	70	273	3	8	6007-444
VR303-28.0	28.0	71	277	3	8	6007-445
VR303-30.0	30.0	73	281	3	8	6007-446
VR303-32.0	32.0	77	317	4	8	6007-447
VR303-35.0	35.0	78	321	4	8	6007-448
VR303-36.0	36.0	79	325	4	8	6007-449
VR303-38.0	38.0	81	329	4	8	6007-450
VR303-40.0	40.0	81	329	4	8	6007-451



Machine Reamers Long Length



Carbide



Work Material / Velocity m/min

GR.1 Non alloyed steels Alloyed Steels	GR.2 Heat resistant steels Stainless steels	GR.3 Hardened steels < 48 HRC	GR.4 Hardened steels 48-56 HRC	GR.6 Iron	GR.7 Titanium	GR.8 Nickel	GR.9 Copper	GR.10 Aluminium
7-25	7-15	5-10	5-10	10-22	10-25	5-20	30-45	20-50

Straight Shank(Order No. VRC02-Dia) Unit:mm

ORDER NO.	Dc h7	Lc mm	L mm	d h6	Z teeth	CODE NO.
VRC02-3.0	3.0	15	100	3.0	4	6008-820
VRC02-3.5	3.5	18	112	3.5	4	6008-821
VRC02-4.0	4.0	19	119	4.0	4	6008-822
VRC02-4.5	4.5	21	126	4.5	4	6008-823
VRC02-5.0	5.0	23	132	5.0	6	6008-824
VRC02-6.0	6.0	26	139	6.0	6	6008-825
VRC02-7.0	7.0	31	156	7.0	6	6008-826
VRC02-8.0	8.0	33	165	8.0	6	6008-827

Straight Shank(Order No. VRC02-Dia) Unit:mm

ORDER NO.	Dc h7	Lc mm	L mm	d h6	Z teeth	CODE NO.
VRC02-9.0	9.0	36	175	9.0	6	6008-828
VRC02-10.0	10.0	38	184	10.0	6	6008-829
VRC02-12.0	12.0	44	205	10.0	6	6008-830
VRC02-14.0	14.0	47	214	12.5	6	6008-831
VRC02-16.0	16.0	52	227	12.5	6	6008-832
VRC02-18.0	18.0	56	241	14.0	6	6008-833
VRC02-20.0	20.0	60	254	16.0	6	6008-834



Hand Reamers - HSS

H.S.S.

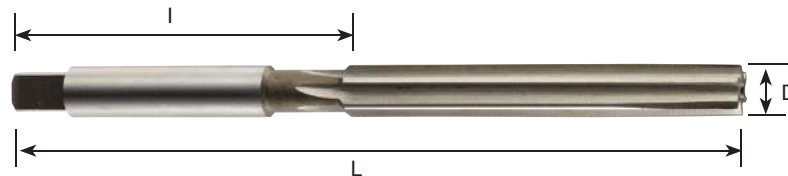

H.S.S.

ORDER NO.	BLADE D	Total Length L	BLADE l	BLADE N	CODE NO.
VHM-03	3	72	40	6	6009-001
VHM-04	4	80	40	6	6009-002
VHM-05	5	90	45	6	6009-003
VHM-06	6	100	50	6	6009-004
VHM-07	7	105	55	6	6009-005
VHM-08	8	115	60	6	6009-006
VHM-09	9	125	65	6	6009-007
VHM-10	10	130	70	6	6009-008
VHM-11	11	140	75	6	6009-009
VHM-12	12	150	75	6	6009-010

Adjustable Reamers



Unique Quality, World Standard

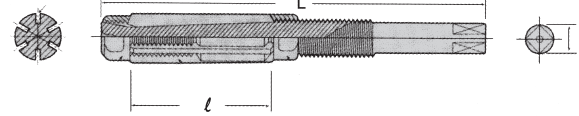

Features Adjustable Reamers

- Because of you can get diameter adjust, one Adjustable reamers function possible as dozens of solid reamers.
- The spare blades save you a lot of economization

ORDER NO.	Range of Adjustment (mm)	Overall Length (mm)	Blade Length (mm)	Weight (kgs)	CODE NO.
VAR-635	6.35~7.15	83	35	0.013	6009-021
VAR-715	7.15~7.95	91	35	0.017	6009-022
VAR-795	7.95~8.70	107	38	0.026	6009-023
VAR-870	8.70~9.50	112	38	0.030	6009-024
VAR-950	9.50~10.25	121	38	0.037	6009-025
VAR-1025	10.25~11	127	38	0.045	6009-026
VAR-1100	11~12	134	42	0.059	6009-027
VAR-1200	12~13.5	141	42	0.071	6009-028
VAR-1350	13.5~15	146	45	0.090	6009-029
VAR-1500	15~16.75	166	53	0.129	6009-030
VAR-1675	16.75~18.25	172	56	0.172	6009-031
VAR-1825	18.25~19.75	178	64	0.227	6009-032
VAR-1975	19.75~21.50	188	67	0.292	6009-033
VAR-2150	21.50~23.75	204	76	0.393	6009-034
VAR-2375	23.75~27	230	83	0.525	6009-035
VAR-2700	27~30.25	254	86	0.785	6009-036
VAR-3025	30.25~34.25	280	98	0.945	6009-037
VAR-3425	34.25~38	305	109	1.36	6009-038
VAR-3800	38~46	356	113	2.11	6009-039
VAR-4600	46~56	407	128	3.60	6009-040
VAR-5600	56~70	457	124	6.14	6009-041
VAR-7000	70~85	509	135	9.87	6009-042

Outside Radius Shape End Mills

Suit For:

MATERIAL: H.S.S.

Plastic molds and cutting radius shape work piece.

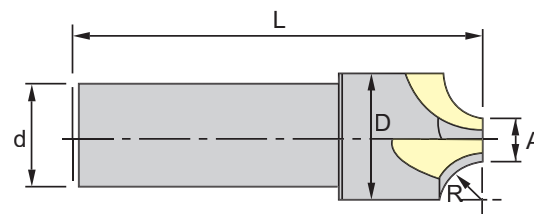

ORDER NO.	R	End D. A	O.D.	Total L	Shank d	Blade No. N	CODE NO.
VCR-010	1	6	8	55	10	3	6009-061
VCR-020	2	6	10	60	12	3	6009-062
VCR-030	3	6	12	60	12	3	6009-063
VCR-040	4	6	14	65	12	3	6009-064
VCR-050	5	7	17	70	16	4	6009-065
VCR-060	6	8	20	75	16	4	6009-066
VCR-070	7	8	22	75	16	4	6009-067
VCR-080	8	9	25	85	20	4	6009-068
VCR-090	9	9	27	85	20	4	6009-069
VCR-100	10	10	30	95	25	4	6009-070

Counterbore End Mills



MATERIAL: H.S.S.



ORDER NO.	Dimension mm	Guide d	Blade O.D.	Shank D	Weight (g)	CODE NO.
VCB-03	3	3.2	5.9	6	18	6009-081
VCB-04	4	4.2	7.4	6	21.5	6009-082
VCB-05	5	5.2	8.9	6	22.5	6009-083
VCB-06	6	6.2	10.4	8	33.5	6009-084
VCB-08	8	8.2	13.4	10	61	6009-085
VCB-10	10	10.3	16.8	12	88	6009-086
VCB-12	12	12.3	18.8	12	120	6009-087
VCB-14	14	14.3	24	12	165	6009-088
VCB-16	16	16.3	26	12	186	6009-089
VCB-18	18	18.3	28	12	195	6009-090

Metal Slitting Saws

MATERIAL: SKH-9



INSIDE DIA. 1" (25.4mm)

ORDER NO.	Thickness	ØO.D.	CODE NO.	ORDER NO.	Thickness	ØO.D.	CODE NO.
VSS-7505	0.5 m/m	75	6009-131	VSS-1005	0.5 m/m	100	6009-151
VSS-7508	0.8 m/m	75	6009-132	VSS-1008	0.8 m/m	100	6009-152
VSS-7510	1.0 m/m	75	6009-133	VSS-1010	1.0 m/m	100	6009-153
VSS-7512	1.2 m/m	75	6009-134	VSS-1012	1.2 m/m	100	6009-154
VSS-7515	1.5 m/m	75	6009-135	VSS-1015	1.5 m/m	100	6009-155
VSS-7518	1.8 m/m	75	6009-136	VSS-1018	1.8 m/m	100	6009-156
VSS-7520	2.0 m/m	75	6009-137	VSS-1020	2.0 m/m	100	6009-157

H.S.S. END MILLS

MATERIAL H.S.S. + CO

NEW

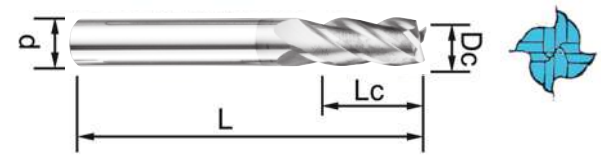
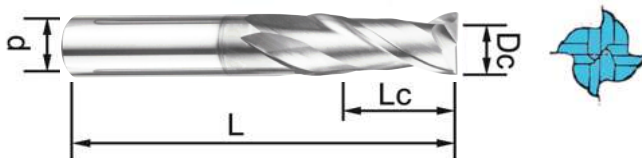

H.S.S. 2FLUTE END MILL

H.S.S. 4FLUTE END MILL

ORDER NO.	Dc	Lc mm	L mm	d	CODE NO.
VES2-3.0	3.0	10	55	6	6009-301
VES2-4.0	4.0	12	55	6	6009-303
VES2-5.0	5.0	15	60	6	6009-305
VES2-6.0	6.0	15	60	6	6009-307
VES2-7.0	7.0	20	70	8	6009-309
VES2-8.0	8.0	20	70	8	6009-311
VES2-9.0	9.0	25	80	10	6009-313
VES2-10.0	10.0	25	80	10	6009-315
VES2-12.0	12.0	30	90	12	6009-318
VES2-14.0	14.0	35	95	12	6009-320
VES2-16.0	16.0	40	105	16	6009-322
VES2-18.0	18.0	40	105	16	6009-324
VES2-20.0	20.0	45	115	20	6009-326

ORDER NO.	Dc	Lc mm	L mm	d	CODE NO.
VES4-3.0	3.0	10	55	6	6009-401
VES4-3.5	3.5	12	60	8	6009-402
VES4-4.0	4.0	12	60	8	6009-403
VES4-4.5	4.5	15	60	8	6009-404
VES4-5.0	5.0	15	60	8	6009-405
VES4-6.0	6.0	15	60	8	6009-407
VES4-7.0	7.0	20	70	8	6009-409
VES4-8.0	8.0	20	70	8	6009-411
VES4-9.0	9.0	25	80	10	6009-413
VES4-10.0	10.0	25	80	10	6009-415
VES4-12.0	12.0	30	90	12	6009-418
VES4-13.0	13.0	35	95	12	6009-419
VES4-14.0	14.0	35	95	12	6009-420
VES4-15.0	15.0	40	105	16	6009-421
VES4-16.0	16.0	40	105	16	6009-422
VES4-17.0	17.0	40	105	16	6009-423
VES4-18.0	18.0	40	105	16	6009-424
VES4-19.0	19.0	45	115	20	6009-425
VES4-20.0	20.0	45	115	20	6009-426



H.S.S. DRILL



With Coating

NEW



Ø1.0, 1.5, 2.0, 2.5, 3.0, 3.5, 4.0, 4.5, 5.0, 5.5, 6.0, 6.5, 7.0, 7.5, 8.0, 8.5, 9.0, 9.5, 10 mm

※HSD-10 Ø1~Ø10MM 19PCS / SET
EACH ONE STEP 0.5MM

Ø1.0, 1.5, 2.0, 2.5, 3.0, 3.5, 4.0, 4.5, 5.0, 5.5, 6.0, 6.5, 7.0, 7.5, 8.0, 8.5, 9.0, 9.5, 10, 10.5, 11, 11.5, 12, 12.5, 13 mm

※HSD-13 Ø1~Ø13MM 25PCS / SET
EACH ONE STEP 0.5MM

ORDER NO.	PCS / SET	WEIGHT (kgs)	CODE NO.
HSD-10	19 PCS	0.7	6010-001
HSD-13	25 PCS	1.3	6010-002



NEW

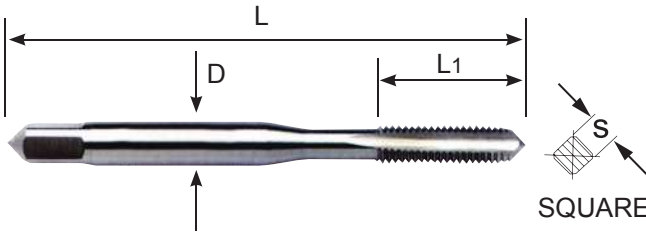

- ISO 2 6H
- HSS
- 60°
- JIS
- ISO 529

ORDER NO.	SIZE x PITCH	ØD	S	L	L1	WEIGHT (kgs)	CODE NO.
VHT-H3	M3 x 0.5P	4	3.2	46	18		6011-001
VHT-H4	M4 x 0.7P	5	4	52	20	0.01	6011-002
VHT-H5	M5 x 0.8P	5.5	4.5	60	22		6011-003
VHT-H6	M6 x 1.0P	6	4.5	62	24		6011-004
VHT-H8	M8 x 1.25P	6.2	5	70	30	0.03	6011-005
VHT-H10	M10 x 1.5P	7	5.5	75	32	0.05	6011-006
VHT-H12	M12 x 1.75P	8.5	6.5	82	38		6011-007
VHT-H14	M14 x 2.0P	10.5	8	88	42		6011-008
VHT-H16	M16 x 2.0P	12.5	10	95	45		6011-009
VHT-H20	M20 x 2.5P	15	12	105	50		6011-010

Spiral Fluted Machine Taps

NEW

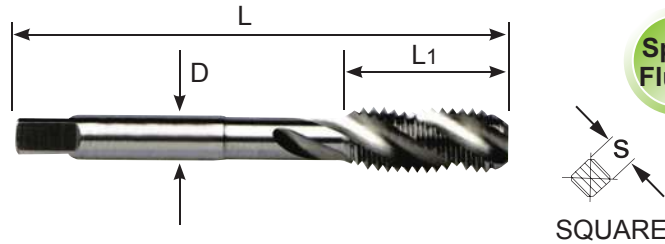

- Spiral Fluted
- ISO 2 6H
- HSS-EV
- 60°
- JIS
- ISO 529

ORDER NO.	SIZE x PITCH	ØD	S	L	L1	WEIGHT (kgs)	CODE NO.
VMT-S3	M3 x 0.5P	4	3.2	46	11	0.01	6011-021
VMT-S4	M4 x 0.7P	5	4	52	13	0.01	6011-022
VMT-S5	M5 x 0.8P	5.5	4.5	60	16	0.02	6011-023
VMT-S6	M6 x 1.0P	6	4.5	62	19	0.02	6011-024
VMT-S8	M8 x 1.25P	6.2	5	70	22	0.03	6011-025
VMT-S10	M10 x 1.5P	7	5.5	75	24	0.05	6011-026
VMT-S12	M12 x 1.75P	8.5	6.5	82	29	0.07	6011-027
VMT-S14	M14 x 2.0P	10.5	8	88	30		6011-028
VMT-S16	M16 x 2.0P	12.5	10	95	32	0.08	6011-029
VMT-S20	M20 x 2.5P	15	12	105	37		6011-030

Spiral Fluted Machine Taps

NEW

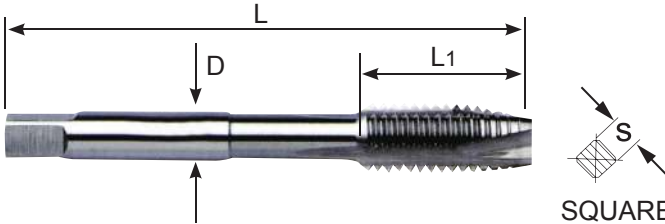

- ISO 2 6H
- HSS-EV
- 60°
- JIS
- ISO 529

ORDER NO.	SIZE x PITCH	ØD	S	L	L1	WEIGHT (kgs)	CODE NO.
VMT-M3	M3 x 0.5P	4	3.2	46	11		6011-041
VMT-M4	M4 x 0.7P	5	4	52	13	0.01	6011-042
VMT-M5	M5 x 0.8P	5.5	4.5	60	16	0.02	6011-043
VMT-M6	M6 x 1.0P	6	4.5	62	19		6011-044
VMT-M8	M8 x 1.25P	6.2	5	70	22		6011-045
VMT-M10	M10 x 1.5P	7	5.5	75	24		6011-046
VMT-M12	M12 x 1.75P	8.5	6.5	82	29		6011-047
VMT-M14	M14 x 2.0P	10.5	8	88	30		6011-048
VMT-M16	M16 x 2.0P	12.5	10	95	32		6011-049
VMT-M20	M20 x 2.5P	15	12	105	37		6011-050

HAND TAPS



Tap Wrenches With Ratchet



CLAMPING RANGE

NEW



Unit : mm

ORDER NO.	SIZE	METRIC	L	PIPE	WEIGHT (kgs)	CODE NO.
VPW-310	1	M3~M10	85	Ø3.0	0.18	6011-801
VPW-512	2	M5~M12	100	Ø9.0	0.31	6011-802



Tap Wrenches With Ratchet

CLAMPING RANGE

NEW

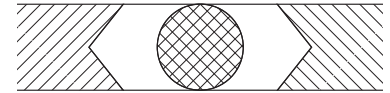

Unit : mm

ORDER NO.	SIZE	METRIC	L	PIPE	WEIGHT (kgs)	CODE NO.
VPW-118	0	M1~M8	125	Ø6.5	0.06	6011-811
VPW-110	1	M1~M10	180	Ø8.0	0.12	6011-812
VPW-112	1-1/2	M1~M12	200	Ø3.1	0.11	6011-813
VPW-412	2	M4~M12	280	Ø3.1~9.0	0.26	6011-814
VPW-520	3	M5~M20	375	Ø3.1~12.0	0.58	6011-815
VPW-927	4	M9~M27	500	Ø3.1~19.0	0.86	6011-816
VPW-1332	5	M13~M32	750	Ø6.5~25.0	1.36	6011-817



Magnetic Tapper

NEW



COST HIGHER



- Suit for large workpiece
- TAP thread capacity M3-M12
- MAX. stroke 60 mm
- Magnetic force 80 kgf
- Horizontal / Vertical
- Portable
- Great for machine case & thin plate tapping job.

EXAMPLE

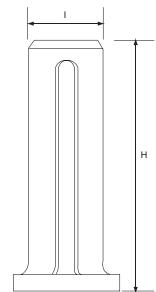
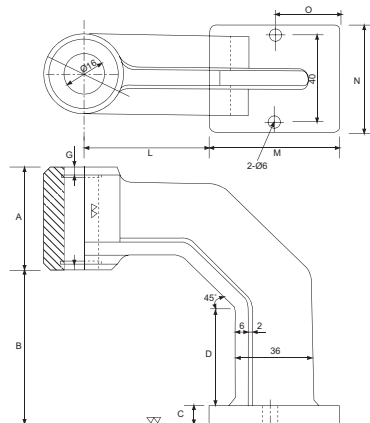

Unit : mm

● Tap & work piece not included

ORDER NO.	A	B	C	D	H	I	L	M	N	O	WEIGHT (kgs)	CODE NO.
VTM-13	50	72	10	45	122	36	60	60	50	30	3.10	2015-731