

S7019

220 - 240V 50 / 60Hz E40



features

- body / lamp holder compartment**
 - body lamp holder compartment is made from die-cast aluminium and powder coated with Akzo Nobel Interpon for protection
- high performance reflector**
 - single piece high purity deep draw aluminium reflector is sealed with silicon gasket over heat resistant tempered glass provide a watertight seal
- glass**
 - fixed thermal resistant tempered glass
- mounting bracket**
 - steel mounting bracket coated with epoxy powder attached with angle adjuster & indicator
- rear cover**
 - easy access to the lamp from the rear cover of the fitting
- lamp holder**
 - E40 lamp holder conforming to EN / VDE standard

technical data

ingress protection • IP66 (lamp fitting)
 voltage • 220 - 240 Vac 50 / 60Hz
 lamp wattage • MH 1000W & HPS 1000W
 holder type • E40
 floodlight maximum weight • 11 kg
 control gear weight • S5100-UA-M : 14 kg / S5100-UA-S : 15.5 kg

dimension

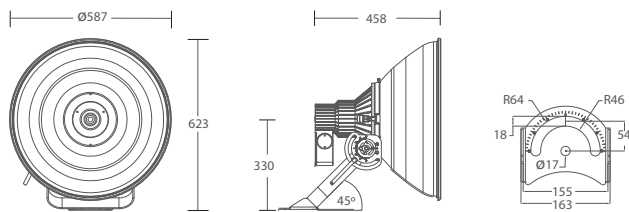

photometric curve

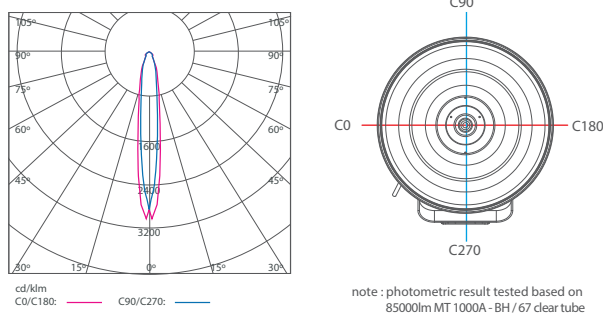

accessories

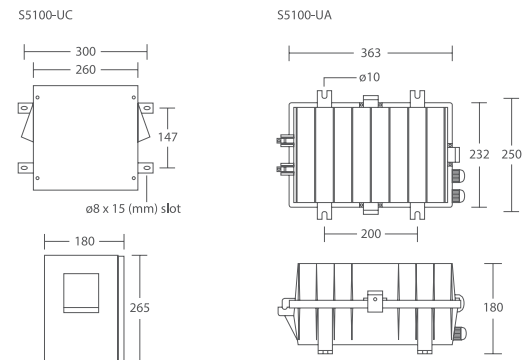

key for standard order coding

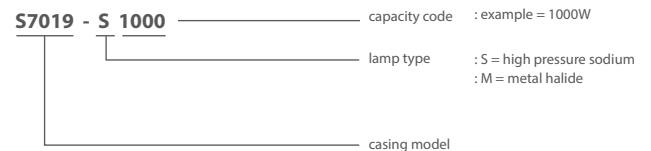

order code

model	lamp type	lamp holder	carton dimension (L x W x H) mm	order code
S7019 MH 1000W	tubular	E40	640 x 650 x 520	S7019-M1000
S7019 HPS 1000W	tubular	E40	640 x 650 x 520	S7019-S1000
accessories	housing material	IP rated		order code
remote control gear (MH 1000W)	die-cast aluminium	IP65		S5100 UA-M1000
remote control gear (HPS 1000W)	die-cast aluminium	IP65		S5100 UA-S1000

note : Due to rapid change and continuous improvement in technology, all specifications are subject to change without prior notice to improve reliability, function or design in order to supply the best product possible.