

### VEL 360/R

### VEL 360/RT



#### Specifications :

Mild Steel Housing  
Prismatic Diffuser  
Stainless Steel Spring Clips

#### Test Standard :

MS 619-2-22:2005  
MS IEC 60598-1:2012

#### Mounting Method :

Recessed Plaster Ceiling  
Hole Cut: 350mm x 125mm

#### Certified by :

SIRIM QAS INTERNATIONAL SDN. BHD.  
JABATAN BOMBA DAN PENYELAMAT MALAYSIA

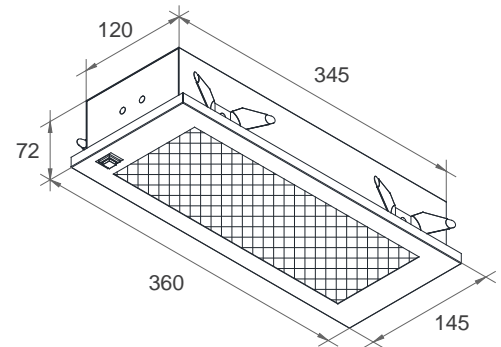

Mains Supply	220 – 240V 50/60Hz	Rating	VEL 360/R	< 0.03A / < 1.2W / 0.32 PF
			VEL 360/RT	0.005A / 1.2W / 0.91 PF
Mode of Operation	Non-Maintained	Rated Lumen		75lm
Lamp	LED 2835 (20 PCS)	Classification / Degree of Protection		Class 1 / IP 20
Battery	VEL 360/R	Ni-Cd AA 3.6V 1000mAh	Max. Operating Temperature (ta)	
	VEL 360/RT	Ni-Cd AA 3.6V 900mAh		
Emergency Duration	3 Hours	Recommended Mounting Height		Min. 3m
Recharge Period	24 Hours	Weight		1.05 KG

Packing : 15 sets per carton box  
Outer carton box : L474 X W447 X H397 mm ( 18.40 kg )  
Inner carton box : L366 X W152 X H84 mm ( 1.15 kg )

We reserve the rights to alternate the specification of its product at any time without prior notice.  
Pictures shown are for illustration purpose only.