







Legend	Model
	VES 402/WR/E
	VES 402/WR/EL
	VES 402/WR/ER
	VES 402/WR/RM
	VES 402/WR/RML
	VES 402/WR/RMR



Specifications :

Polycarbonate Housing
Polycarbonate Diffuser
Powder Coated Mild Steel Frame
Powder Coated EG Steel Recessed Box

Test According to :

SS 563
SS IEC 60598-2-22

Mounting Method :

Recessed Wall Mounted

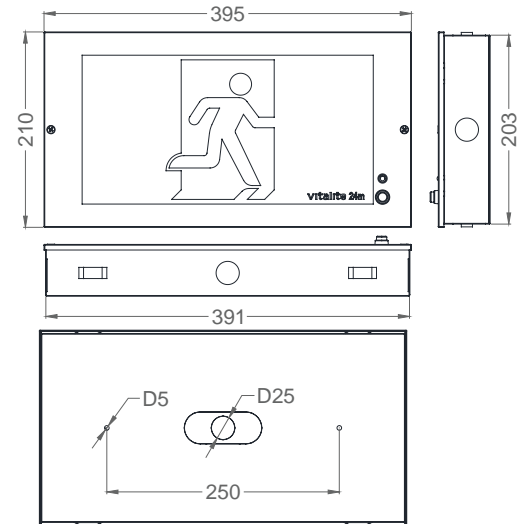
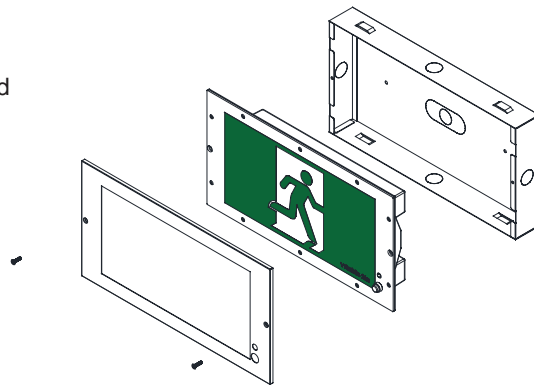

Mains Supply	220 – 240V 50/60Hz	Rating	0.01A / 3.15W / 0.95 PF
Mode of Operation	Maintained	Classification	Class 1
Lamp	LED 2835 (3 PCS)	Degree of Protection	IP 65
Battery	Ni-Cd AA 3.6V 900mAh	Max. Operating Temperature (ta)	40°C
Emergency Duration	2 Hours	Recommended Mounting Height	300mm
Recharge Period	24 Hours	Weight	1.57 KG