

LED POOL LIGHT

EB-PL180



Dustproof



Waterproof



Anti-mosquito

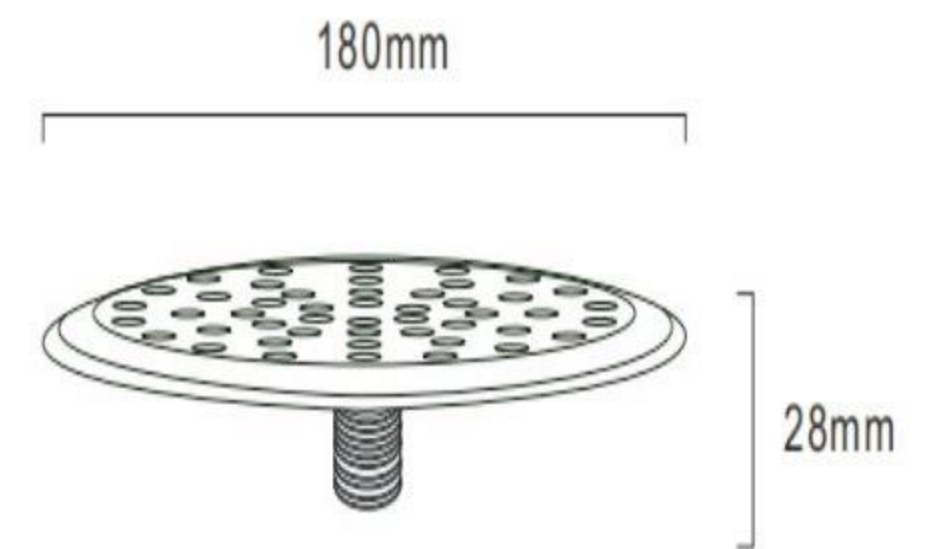

Watt	20W	20W
Input Voltage:	DC12V	DC12V
Max Luminaire Efficiency:	$\geq 80\text{Lm/w}(\pm 5\%)$	$\geq 80\text{Lm/w}(\pm 5\%)$
CCT:	3000K	RGB
CRI:	$\geq 80(\pm 2)$	$\geq 80(\pm 2)$
LED Chip QTY	Epistar SMD/50pcs	Epistar SMD/50pcs
Body Dimension(mm):	$\Phi 180 * H25$	$\Phi 180 * H25$
IP Rating:	Ip68	Ip68
Body Colour:	White	White
Material:	PC	PC
Lifespan:	30000Hrs	30000Hrs
Ambient Temperature:	$-25^{\circ}\text{C} \sim +55^{\circ}\text{C}$	$-25^{\circ}\text{C} \sim +55^{\circ}\text{C}$

Product Overview

Application:

Pool, Fountain, River, etc...

