



## LED STREET LIGHT



## APPLICATION

- Ideal for Parking Areas, Stadiums, Pathway, Garden, Commercial and All Residential Area.



## FEATURES

- High Brightness and Long Life LED Chips. (30,000Hrs)
- Operating Temperature -20°C ~ 50°C.
- Solid Aluminium Die-Casting Housing.
- Polycarbonate Material Diffuser.



<< 50W/100W/150W  
ANGLE ADJUSTABLE  
FOR POST TOP MOUNTING



MODEL	POWER (W)	CCT (K)	LUMEN (LM)	SIZE L x W x H (mm)	MOUNTING TYPE ADJUSTMENT	POLE/ARM DIAMETER Ø (mm)	NET WEIGHT (kg)	PACKING
BSSL-1050-1	50W	3000/5000	6000	470 x 149 x 99	Post top	45-60	1.5	4/CTN
BSSL-1100-1	100W	3000/5000	12000	567 x 179 x 99	&	45-60	2.0	2/CTN
BSSL-1150-1	150W	3000/5000	18000	633 x 203 x 99	Side Entry	45-60	2.8	2/CTN
BSSL-1200-1	200W	3000/5000	24000	624 x 234 x 92	Side Entry	45-60	3.2	2/CTN

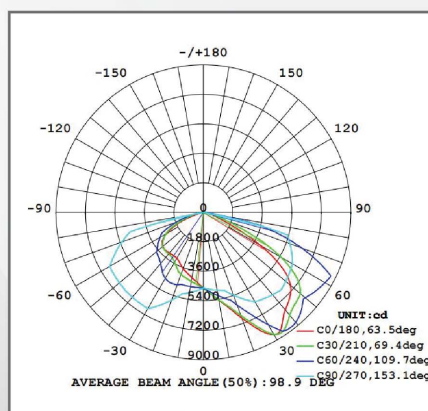
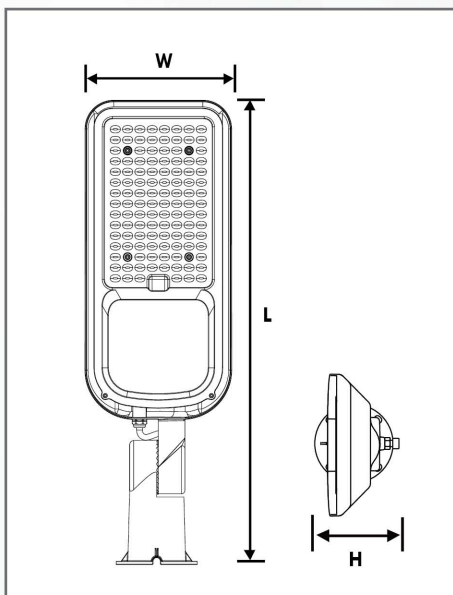

PHOTOMETRY

