



Version: 01

	Product Name	100W FGA Food Grade LED High Bay
	Item No.	VSL-FGA 100W

Optical Data			
LED Type	Nichia	CCT	3000K, 4000K, 5000K
System Efficacy	140(±5%)lm/W(5000K Ra70)	CRI	Ra70, Ra80
Luminous Flux	14000(±5%)lm(5000K Ra70)	Beam Angle	H00A02, H00B03, H00B04, H25201, H25202, H25203

Electrical Data			
Power Supply	Mean Well	Power Frequency	50/60Hz
Input Voltage	AC100-240V / AC100-277V	Power Factor	>0.93
Input Surge Protection	2kV line-line, 4kV line-earth		

Others			
System Power Consumption	100±5W	Storage Temperature	-40°C to +70°C(-40°F to +158°F)
Housing	Aluminum Alloy	Operating Temperature	-30°C to +50°C(-22°F to +122°F)
Ingress Protection	IP65	Operating Humidity	15-90%RH
LED Life Span	>50000Hrs(Ta=30°C @L70)	Luminaire Net Weight	7.2±0.3kg (15.87±0.66Lbs)
Outlook Dimensions	φ489×200mm (19.25"×7.87")	Export Carton Size	560×260×565mm (22.05"×10.24×22.24")
Protection Class	Class I		
Certification	CE/CB/D-mark/RoHS/UL/DLC/SAA/EMC/LM79/TM21/ISTMT/LCP		

Optional Info.	
Installation Method	Loop Hanging
Intelligent Control	DALI control

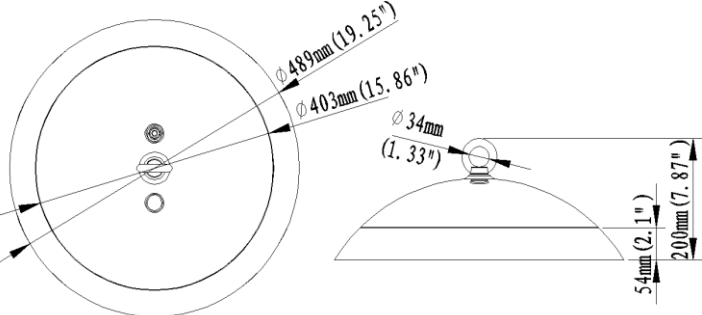
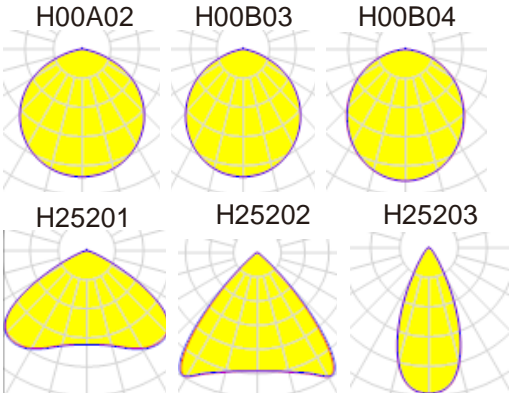
Physical Dimensions	Light Distribution Curve
	



Version: 01

	Product Name	120W FGA Food Grade LED High Bay
	Item No.	VSL-FGA 120W

Optical Data			
LED Type	Nichia	CCT	3000K, 4000K, 5000K
System Efficacy	140(±5%)lm/W(5000K Ra70)	CRI	Ra70, Ra80
Luminous Flux	16800(±5%)lm(5000K Ra70)	Beam Angle	H00A02, H00B03, H00B04, H25201, H25202, H25203

Electrical Data			
Power Supply	Mean Well	Power Frequency	50/60Hz
Input Voltage	AC100-240V / AC100-277V	Power Factor	>0.93
Input Surge Protection	2kV line-line, 4kV line-earth		

Others			
System Power Consumption	120±6W	Storage Temperature	-40°C to +70°C(-40°F to +158°F)
Housing	Aluminum Alloy	Operating Temperature	-30°C to +50°C(-22°F to +122°F)
Ingress Protection	IP65	Operating Humidity	15-90%RH
LED Life Span	>50000Hrs(Ta=30°C @L70)	Luminaire Net Weight	7.2±0.3kg (15.87±0.66Lbs)
Outlook Dimensions	φ489×200mm (19.25"×7.87")	Export Carton Size	560×260×565mm (22.05"×10.24×22.24")
Protection Class	Class I		
Certification	CE/CB/D-mark/RoHS/UL/DLC/SAA/EMC/LM79/TM21/ISTMT/LCP		

Optional Info.	
Installation Method	Loop Hanging
Intelligent Control	DALI control / Microwave Sensor / Zigbee Wireless Control

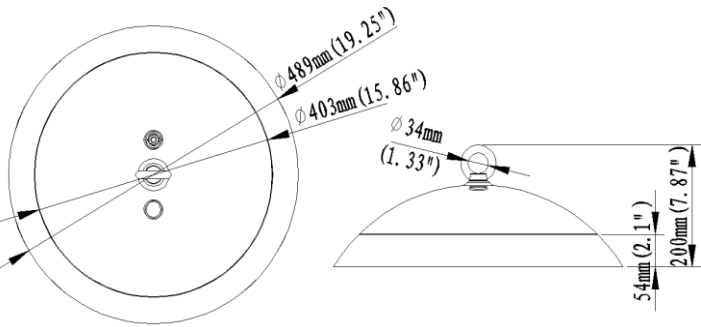
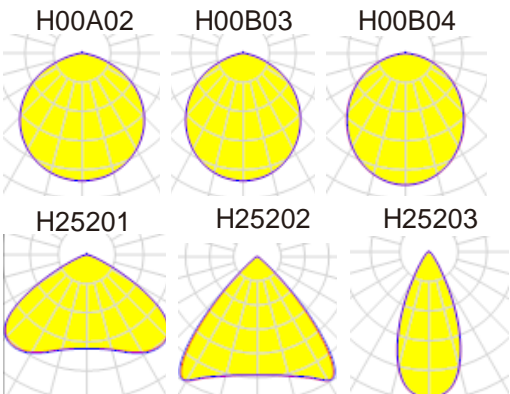
Physical Dimensions	Light Distribution Curve
	



Version: 01

	Product Name	150W FGA Food Grade LED High Bay
	Item No.	VSL-FGA 150W

Optical Data			
LED Type	Nichia	CCT	3000K, 4000K, 5000K
System Efficacy	140(±5%)lm/W(5000K Ra70)	CRI	Ra70, Ra80
Luminous Flux	21000(±5%)lm(5000K Ra70)	Beam Angle	H00A02, H00B03, H00B04, H25201, H25202, H25203

Electrical Data			
Power Supply	Mean Well	Power Frequency	50/60Hz
Input Voltage	AC100-240V / AC100-277V	Power Factor	>0.92
Input Surge Protection	2kV line-line, 4kV line-earth		

Others			
System Power Consumption	150±7W	Storage Temperature	-40°C to +70°C(-40°F to +158°F)
Housing	Aluminum Alloy	Operating Temperature	-30°C to +50°C(-22°F to +122°F)
Ingress Protection	IP65	Operating Humidity	15-90%RH
LED Life Span	>50000Hrs(Ta=30°C @L70)	Luminaire Net Weight	7.2±0.3kg (15.87±0.66Lbs)
Outlook Dimensions	φ489×200mm (19.25"×7.87")	Export Carton Size	560×260×565mm (22.05"×10.24×22.24")
Protection Class	Class I		
Certification	CE/CB/D-mark/RoHS/UL/DLC/SAA/EMC/LM79/TM21/ISTMT/LCP		

Optional Info.	
Installation Method	Loop Hanging
Intelligent Control	DALI control / Microwave Sensor / Zigbee Wireless Control

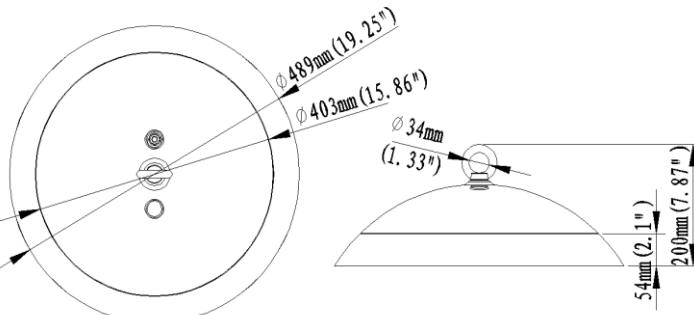
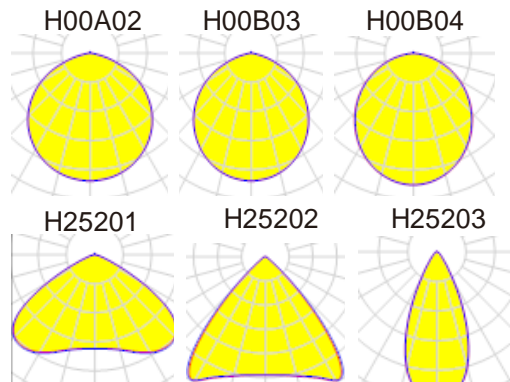
Physical Dimensions	Light Distribution Curve
	



Version: 01

	Product Name	200W FGA Food Grade LED High Bay
	Item No.	VSL-FGA 200W

Optical Data			
LED Type	Nichia	CCT	3000K, 4000K, 5000K
System Efficacy	140(±5%)lm/W(5000K Ra70)	CRI	Ra70, Ra80
Luminous Flux	28000(±5%)lm(5000K Ra70)	Beam Angle	H00A02, H00B03, H00B04, H25201, H25202, H25203

Electrical Data			
Power Supply	Mean Well	Power Frequency	50/60Hz
Input Voltage	AC100-240V / AC100-277V	Power Factor	>0.92
Input Surge Protection	2kV line-line, 4kV line-earth		

Others			
System Power Consumption	200±10W	Storage Temperature	-40°C to +70°C(-40°F to +158°F)
Housing	Aluminum Alloy	Operating Temperature	-30°C to +50°C(-22°F to +122°F)
Ingress Protection	IP65	Operating Humidity	15-90%RH
LED Life Span	>50000Hrs(Ta=30°C @L70)	Luminaire Net Weight	7.2±0.3kg (15.87±0.66Lbs)
Outlook Dimensions	φ489×200mm (19.25"×7.87")	Export Carton Size	560×260×565mm (22.05"×10.24×22.24")
Protection Class	Class I		
Certification	CE/CB/D-mark/RoHS/UL/DLC/SAA/EMC/LM79/TM21/ISTMT/LCP		

Optional Info.	
Installation Method	Loop Hanging
Intelligent Control	DALI control / Microwave Sensor / Zigbee Wireless Control

Physical Dimensions	Light Distribution Curve
