



# FGA3 FOOD GRADE LED HIGH BAY



Microwave Sensor



## Specifications

Efficiency	140lm/W
Input Voltage	AC 100 ~ 240V
PF	>0.95
LED	LUMILEDS 3030
Driver	SOSEN
CCT	3000K / 4000K / 5000K / 5700K / 6500K
CRI	80Ra
Beam Angle	60° / 90° / 120°
Rated Life	50,000Hrs
IP	IP66 & IP69K
Operating Temperature	-30°C ~ +45°C
Material	Aluminium Alloy (body) Polycarbonate (lens / reflector)

## Features:

- IP69K NSF Certified High Bay with Optional Control (Microwave Sensor, Dimmable, DALI, Zigbee)
- Big heat sink  $\phi$ 400mm and excellent dissipation.
- Smooth exterior with no exposed fasteners
- Built-in motion sensor is optional.
- Wire guard, PC or Aluminum reflectors available.
- Versatile eye bolt mount, hook mount and 1/4, 3/4 pipe mount.
- Built-in surge protection 4kV (line-line), 4kV (line-earth)

## Applications:

Ideal for food processing industry, warehouse, retails, wholesale, and NSF certified required.

## Compliance Standard:

LED LM-80  
 Driver CCC, CE, ENEC, UL, CUL  
 EN61347, IEC 61347, EN61000, EN55015  
 Luminaire CB, CE, RoHS, SAA, NSF



Model	Power	Lumen	LED Type	Weight
VSL-FGA3-100	100W	14,000Lm	LED 3030	4.66kg
VSL-FGA3-120	120W	16,800Lm	LED 3030	4.66kg
VSL-FGA3-150	150W	21,000Lm	LED 3030	4.66kg



**Dimension**

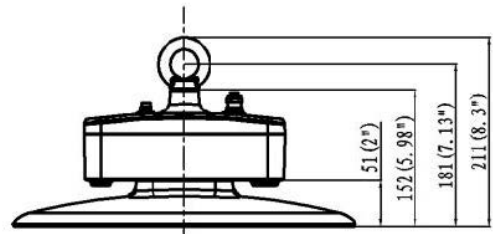
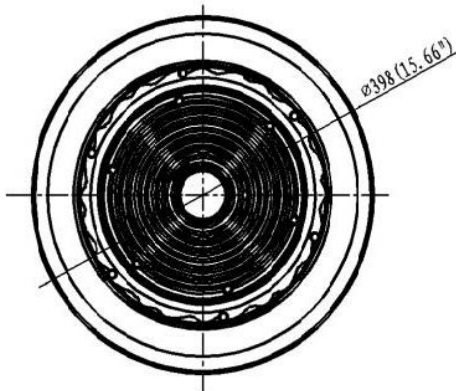

**Photometric**

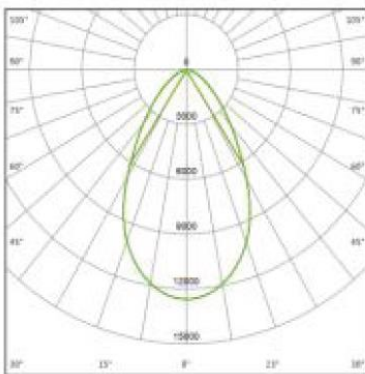

H00129

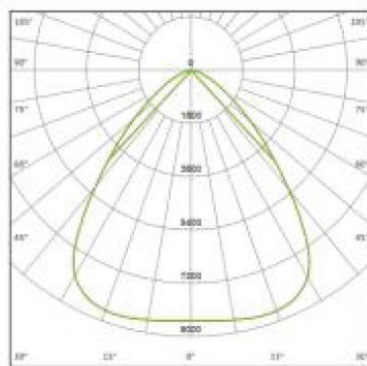

H00125

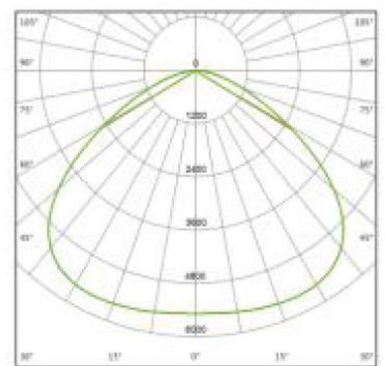

H00128



IP66, IP69K rated for safe and clean environment.



## Optional Parts



HD06VCRH – Microwave Motion Sensor



HD03R – Remote Control

## Installation



Loop Hanging

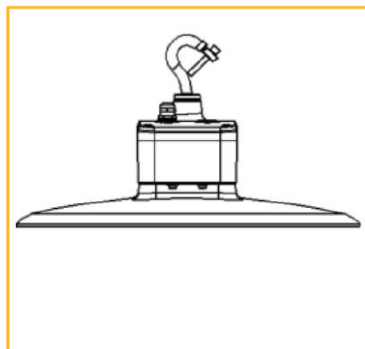

Hook Mounting

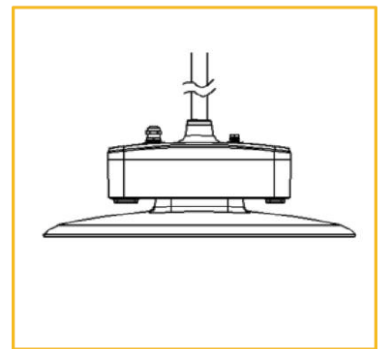

Pipe Mounting