



YH3 LED FLOOD LIGHT



Specifications

Efficiency	140Lm/W
Input Voltage	AC 100 ~ 277V
PF	> 0.95
LED	SAN'AN
Driver	LIFUD
CCT	3000K / 4000K / 5000K / 5700K / 6500K
CRI	80Ra
Beam Angle	30° / 60° / 90° / 120°
Rated Life	50,000Hrs
IP / IK	IP66
Operating Temperature	-20°C ~ +45°C
Material	ADC12 Aluminium (body) Tempered Glass (cover)

Features:

- Integrated die-casting aluminium housing.
- Special treatment surface with elegant shape.
- Designed with good heat dissipation.
- Over-current, over-voltage, lightning, high temperature protection to fully guarantee the lifespan and stable performance.
- Built-in surge protection 6kV (line-line), 6kV (line-earth)
- Flicker free
- THD <15%
- Respirator to prevent condensation within light fixture.
- Lockable bracket to secure mounting angle.

Applications:

Ideal for compound lighting, building, industrial areas, warehouse, and advertisement board.

Compliance Standard:

LED LM-80
Driver TUV-ENEC, CE, RCM, SAA, CB, FCC, UL
EN61347, EN55015, EN61000, EN61547

Model	Power	Lumen	Weight
VSL-YH3-50	50W	7,000Lm	2.6kg
VSL-YH3-100	100W	14,000Lm	4.0kg
VSL-YH3-150	150W	21,000Lm	5.1kg
VSL-YH3-200	200W	28,000Lm	6.2kg
VSL-YH3-250	250W	35,000Lm	7.6kg
VSL-YH3-300	300W	42,000Lm	8.0kg

Dimension

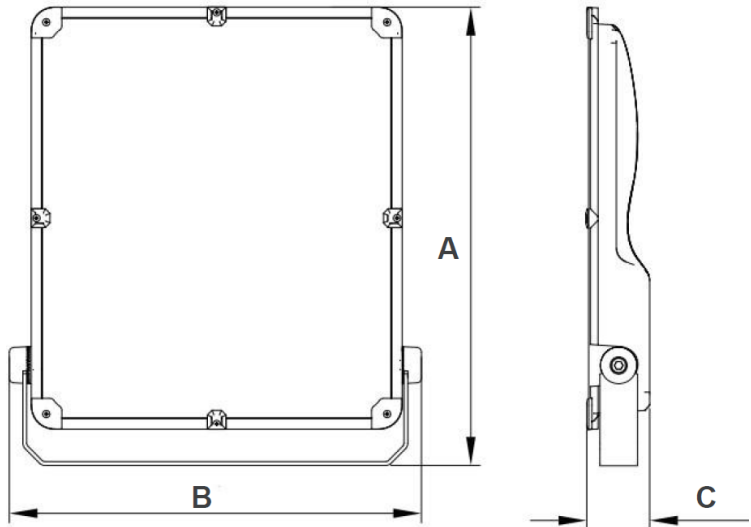

Model	A(mm)	B(mm)	C(mm)
50W	312	216	52
100W	368	342	55
150W	411	367	57
200W	421	392	57
250W	483	439	67
300W	483	439	67

Photometric