

-FUJIOH-

JAPANESE PRECISION CULINARY PERFECTION

PRODUCT CATALOGUE 2024 VOL 1



www.fujioh.com/my

FUJIOH TECHNOLOGY / RECTIFIER PANEL

FUJIOH cooker hood includes a specially designed rectifier panel. Engineered to reduce the air inlet opening, the rectifier panel allows adjustable suction from bottom to improve suction power from the upper, left and right side. The increased suction speed thus improves the efficiency of the fume capturing capacity.

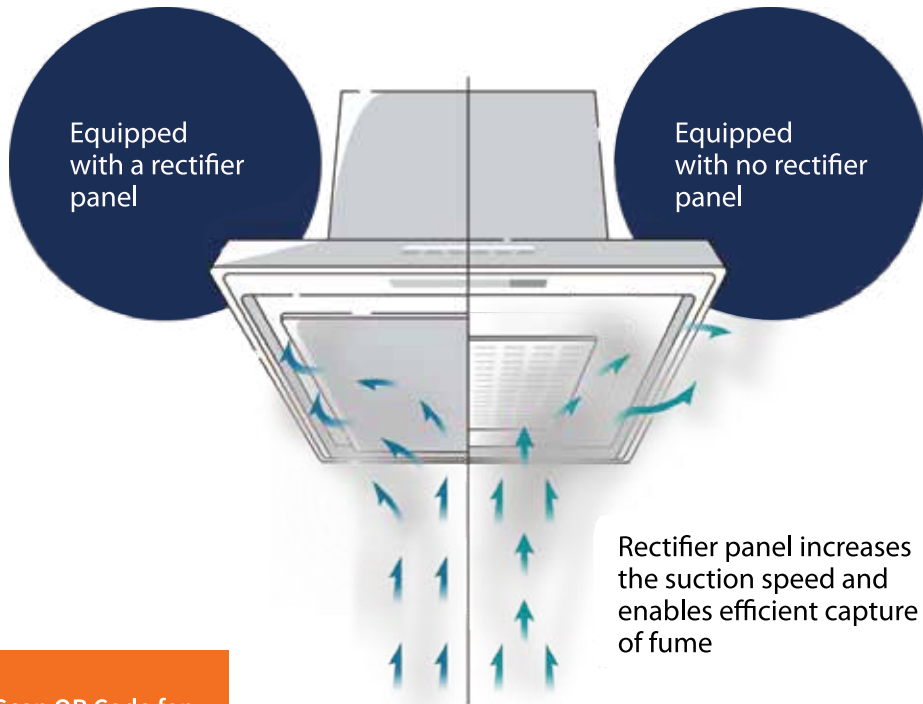

Scan QR Code for
more information

Smoke Capture Tests and Advanced Design for Optimal Performance and Quality

FUJIOH conducts comprehensive smoke capturing tests on all models to ensure optimal suction performance.

Furthermore, we meticulously determine the ideal shape and positioning of rectifier panels through flow path analysis, whenever required.

This meticulous approach guarantees the maintenance of high-quality standards throughout our product line.

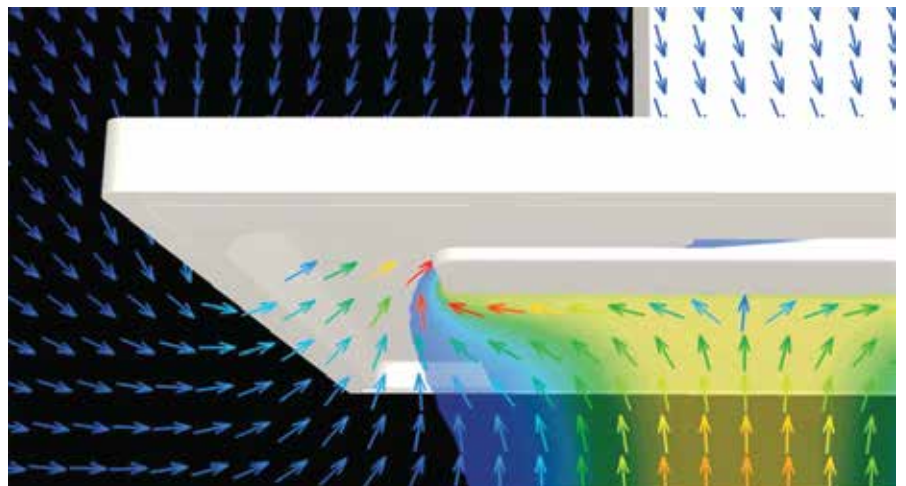

Detailed examination through flow path analysis

* FUJIOH Technologies are applied to selected products only.

FUJIOH TECHNOLOGY / FUNCTIONAL COATING

SUPER KIREI COATING



- SUPER KIREI COATING repels oil instantly, reducing adhesion on the fan surface.
- It uses centrifugal force to separate and collect oil on a tray.
- This dual-action approach extends the fan's lifespan and keeps it looking pristine.

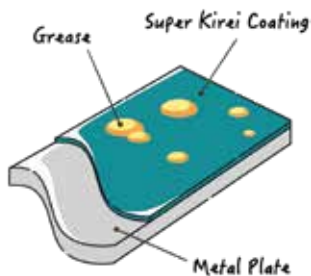

OIL REPELLENT COATING



- OIL REPELLENT COATING effectively repels oil stains from sticking to the surface.
- It allows for easy removal of oil with a damp cloth.
- Saves time and effort in maintaining a clean hood after use.

HYDROPHILIC COATING

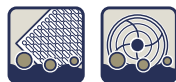

- HYDROPHILIC COATING works well with water, making it easy to remove oil when washed.
- Simplifies maintenance of greasy filters.
- Reduces the difficulty and effort in cleaning.



*FUJIOH Technologies are applied to selected products only.

-FUJIOH-

HOOD /

FR-CL1890 V/R

オイルスマッシャーで、
油に強いキッチンへ。

Your solution for an oil-free kitchen

Cooking with oil means delicious meals for your family but an oily kitchen as well. Unless you have a cooker hood with Oil Smasher.

This state-of-the-art, super-sleek hood features patented Oil Smasher technology. An internal high-speed spinning disk captures the oil to stop build-up on your kitchen surfaces. The innovative cleaning reminder alarm lets you know when it's time to clean the disk. Simply remove, wash easily and replace as new. Your kitchen has never felt so clean.

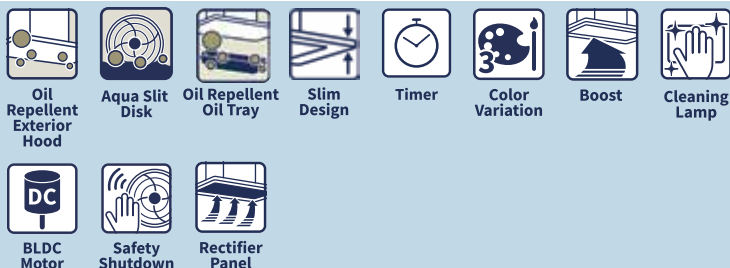

SPECIFICATIONS

Type	Ventilating / Recycling
Hood Body	SPCC with Oil Repellent Coating
Filter	Aqua Slit Disk with Hydrophilic Coating
Motor	BLDC Motor
Speed	3 Speeds & Boost Mode with 24-hr mode
Timer	3/15/30 min & Cleaning Lamp Function
Oil Capturing Ratio [%]	Ventilating : 91 Recycling : 94
Sound Level at 240V [dB]	Ventilating : 32 - 54 Recycling : 40 - 57
Dimensions [mm]	Ventilating : W900 x D600 x H550 - 960 Recycling : W900 x D600 x H750 - 800
Duct Diameter [mm]	Φ150
RCP	WM RM8,498 EM RM8,698

* 4 years general warranty for motor and parts.



GOOD DESIGN
AWARD 2017

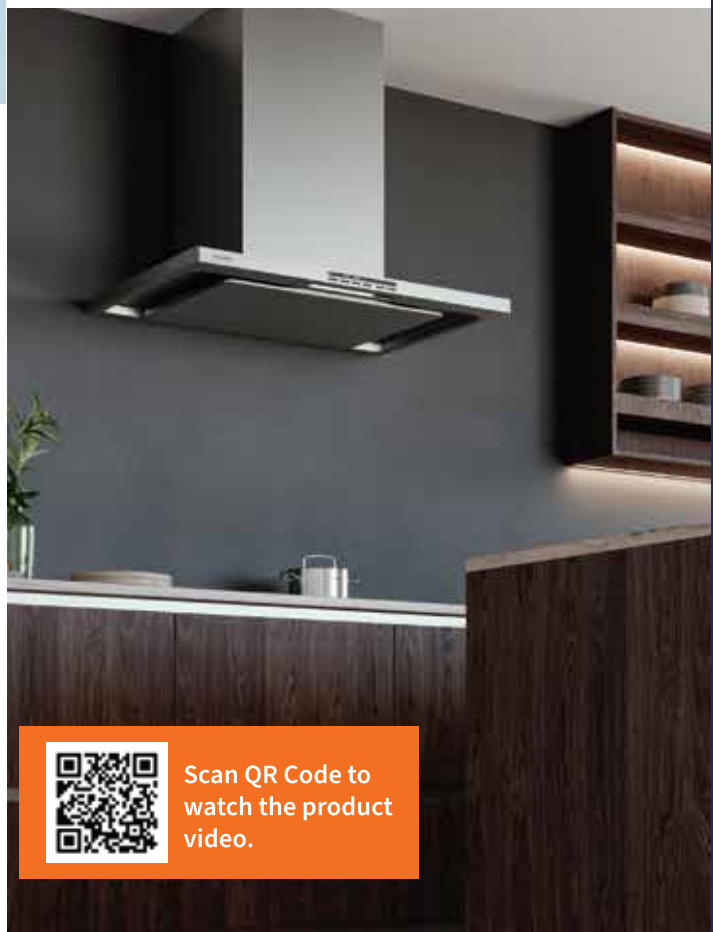

Scan QR Code to
watch the product
video.



RS / Rich Silver

MADE IN
JAPAN
日本製



W / White



SV / Silver Metallic



XBK/ Texture Black

ADVANCED FUNCTIONS

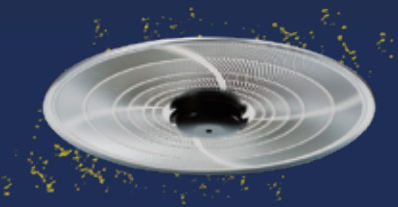

Aqua Slit Disk

Oil capturing ratio up to 94%.

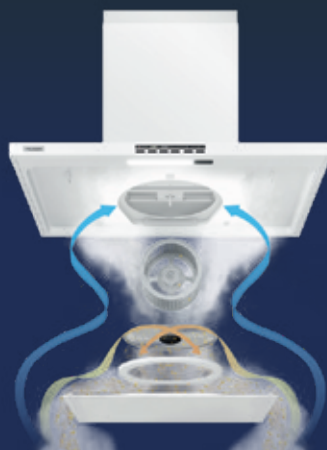

Oil Smasher Technology

High-speed spinning disk prevents oil from reaching fan & motor.



Oil Repellent Exterior

Easy wiping and cleaning of exterior surface.

-FUJIOH-

HOOD /

FR-SC2090 V/R

中も外も、
キレイがつづく。

Immaculate outside in

A fusion cooker hood of an ergonomic inclined design and easy cleaning feature bringing cleanliness to a revolutionized preeminent level. Your cooker hood has never been cleaner than before, both outside in.



Super
Kirei Fan



Aqua
Slit Filter



Oil
Repellent
Exterior
Hood



Rectifier
Panel



Color
Variation

SPECIFICATIONS

Type	Ventilating / Recycling
Hood Body	SPCC with Oil Repellent Coating
Filter	Aqua Slit Filter with Hydrophilic Coating
Motor	AC Motor
Speed	3 Speeds
Timer	3 mins
Oil Capturing Ratio [%]	Ventilating : 85 Recycling : 92
Sound Level at 240V [dB]	Ventilating : 47 - 56 Recycling : 48 - 52
Dimensions [mm]	Ventilating : W900 × D544 × H1045 - 1345 Recycling : W900 × D544 × H490
Duct Diameter [mm]	Φ150
FR-SC2090 R (With RUT90 Recycle Panel)	
RCP	WM RM6,198 EM RM6,398
FR-SC2090 V (Without GFO Duct Cover)	
RCP	WM RM5,698 EM RM5,898
FR-SC2090 V (With GFO Duct Cover)	
RCP	WM RM6,198 EM RM6,398
FR-SC2011 V (With GFO Duct Cover)	
RCP	WM RM8,298 EM RM8,498



Scan QR Code to
watch the product
video.

* 4 years general warranty for motor and parts.



RS / Rich Silver

MADE IN
JAPAN
日本製



XW / Texture White



XBK / Texture Black



SM / Silver Metallic

ADVANCED FUNCTIONS



Super Kirei Fan

Eliminate the accumulation of oil and stain build-up on the fan.



Advance Oil Capturing

Up to 92% oil capturing ratio through advanced oil separation process.



Aqua Slit Filter

Filter with Hydrophilic Coating can be washed easily by using only water.

-FUJIOH-

HOOD /

FR-ST2190 V

快適さと、
デザイン性の融合。

Create a fusion of comfort and good look kitchen

Introducing FR-ST2190 cooker hood with excellent ventilation power. Works perfectly for open kitchen and cooking lovers!

This fully made-in-Japan cooker hood is excellent at removing fumes from the kitchen area and it comes in 3 different colours that aesthetically go well with any kitchen interiors.



Super Kirei Fan



Oil Repellent Fan Guard



Oil Repellent Exterior Hood



Rectifier Panel



Timer



Color Variation



Boost



Texture Coating



Auto Fan Clean

SPECIFICATIONS

Type	Ventilating
Hood Body	SPCC with Oil Repellent Coating
Filter	Oil Repellent Fan Guard
Motor	AC Motor
Speed	3 Speeds & Boost Mode
Timer	3 mins & Auto Fan Clean
Oil Capturing Ratio [%]	84
Sound Level at 240V [dB]	40 - 56
Dimensions [mm]	W895 x 525 x H650 - 1000
Duct Diameter [mm]	Φ180
RCP	WM RM6,198 EM RM6,398



Scan QR Code to
watch the product
video.

* 4 years general warranty for motor and parts.





XBK / Texture Black

MADE IN
JAPAN
日本製



XW / Texture White



SV / Silver Metallic

ADVANCED FUNCTIONS

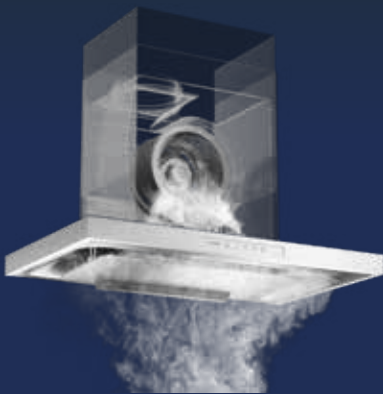

High Air Flow

Enhanced high airflow & fume suction.



Super Kirei Fan

Eliminate the accumulation of oil and stain build-up on the fan.



Oil Repellent Exterior

Easy wiping and cleaning of exterior surface.

-FUJIOH-

HOOD /

FR-FS2290 VP/RP

シンプルさの中に、
少しの個性を。

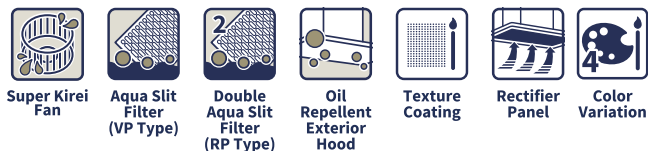

XW / Texture White

SM / Silver Metallic

RS / Rich Silver

ADVANCED FUNCTIONS

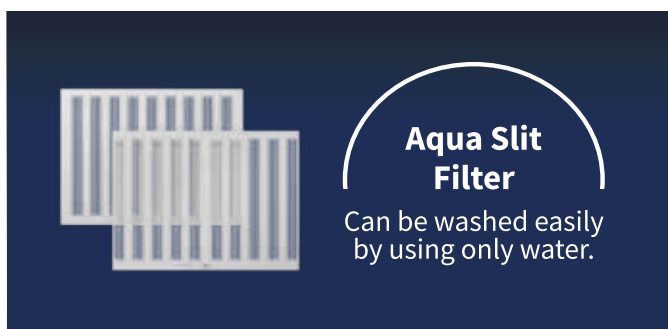

SPECIFICATIONS

Type	Ventilating / Recycling
Hood Body	SPCC with Oil Repellent Coating
Filter	Aqua Slit Filter with Hydrophilic Coating
Motor	AC Motor
Speed	3 Speeds
Timer	-
Oil Capturing Ratio [%]	Ventilating : 88 Recycling : 92
Sound Level at 240V [dB]	Ventilating : 41 - 52 Recycling : 47 - 53
Dimensions [mm]	W890 x D550 x H150
Duct Diameter [mm]	Φ150
RCP	WM RM3,798 EM RM3,998

* 4 years general warranty for motor and parts.

-FUJIOH-

HOOD /

FR-MS2390 V/R



機能性と、
美しさの共存。



Aqua Slit Filter



Gesture Control



Color Variation



Rectifier Panel



Timer



SUS 304

SUS304 Body (SS Model)



BK / Black



W / White

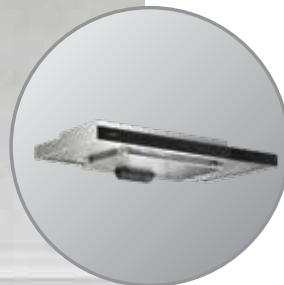

SS / Stainless Steel



Scan QR Code to watch the product video.

ADVANCED FUNCTIONS

Aqua Slit Filter

Filter with Hydrophilic Coating can be washed easily by using only water.

Gesture Control

Allow operation without touching with wet hands.

SPECIFICATIONS

Type	Ventilating / Recycling
Hood Body	SPCC with Coated Paint / Stainless Steel (SUS304)
Filter	Aqua Slit Filter with Hydrophilic Coating
Motor	AC Motor
Speed	3 Speeds
Timer	3 mins
Oil Capturing Ratio [%]	Ventilating : 86 Recycling : 89
Sound Level at 240V [dB]	Ventilating : 47 - 59 Recycling : 40 - 56
Dimensions [mm]	W900 x D460 x H120
Duct Diameter [mm]	Φ150
RCP	WM RM1,698 EM RM1,898

* 4 years general warranty for motor and parts.

-FUJIOH-

HOOD /

FR-SD2290 V

魅せるデザインに、
充実の機能を。



Timer



Boost



Heat
Clean



BLDC
Motor



Auto Flap



FLBK / Full Black



Scan QR Code to
watch the product
video.

ADVANCED FUNCTIONS

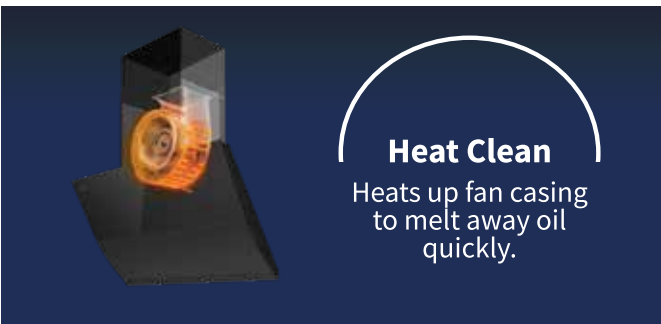
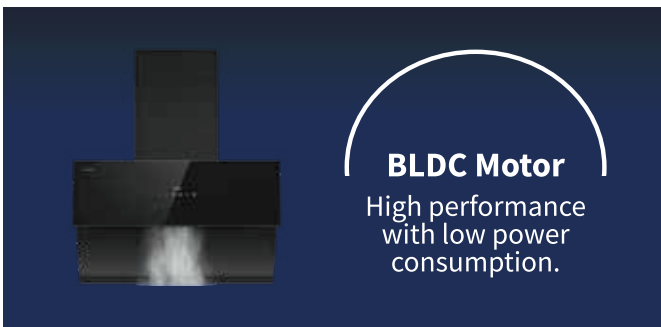

SPECIFICATIONS

Type	Ventilating
Hood Body	Stainless Steel with Coated Paint
Filter	Fan Guard
Motor	BLDC Motor
Speed	3 Speeds & Boost Mode
Timer	3 mins
Oil Capturing Ratio [%]	82
Sound Level at 240V [dB]	41 - 54
Dimensions [mm]	W895 x D362 x H985 - 1185
Duct Diameter [mm]	Φ170
RCP	WM RM3,398 EM RM3,598

* 4 years general warranty for motor and parts.

-FUJIOH-

HOOD /

FR-LT2290 V



Cooker Hood

高い性能を、
タッチレスで実現。



Gesture Control



Timer



Rectifier Panel



Boost



Texture Coating



FLBK / Full Black

ADVANCED FUNCTIONS

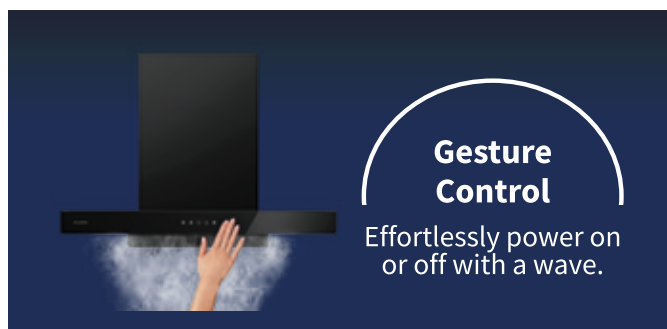

SPECIFICATIONS

Type	Ventilating
Hood Body	SPCC with Coated Paint
Filter	Fan Guard
Motor	AC Motor
Speed	2 Speeds & Boost Mode
Timer	3 mins
Oil Capturing Ratio [%]	83
Sound Level at 240V [dB]	42 - 53
Dimensions [mm]	W896 x D494 x H672 - 975
Duct Diameter [mm]	Φ190
RCP WM RM2,898 EM RM3,098	

* 4 years general warranty for motor and parts.

-FUJIOH-

HOOD /

FR-MT1990 V

楽しい料理の、
強い味方。



ADVANCED FUNCTIONS

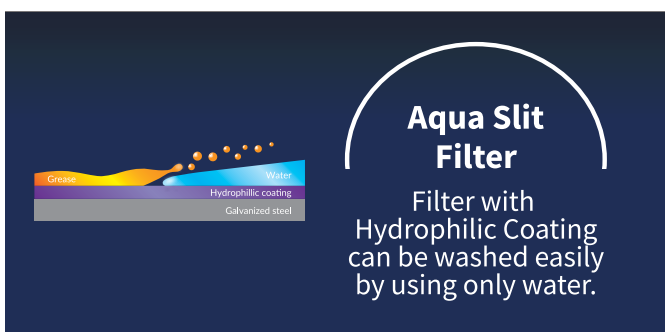

SPECIFICATIONS

Type	Ventilating
Hood Body	Stainless Steel (SUS304)
Filter	Aqua Slit Filter with Hydrophilic Coating
Motor	AC Motor
Speed	3 Speeds
Timer	3/6/9 mins
Oil Capturing Ratio [%]	84
Sound Level at 240V [dB]	35 - 52
Dimensions [mm]	W900 x D505 x H600 - 1030
Duct Diameter [mm]	Φ150
RCP	WM RM2,898 EM RM3,098

* 4 years general warranty for motor and parts.

-FUJIOH-

HOOD /

FR-HT2190 V



シンプルで、
エレガント。



FLBK / Full Black

ADVANCED FUNCTIONS

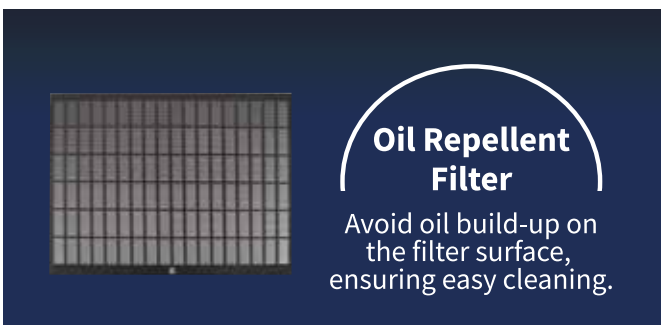

SPECIFICATIONS

Type	Ventilating
Hood Body	SPCC with Coated Paint
Filter	Oil Repellent Filter
Motor	AC Motor
Speed	3 Speeds
Timer	9 mins
Oil Capturing Ratio [%]	88
Sound Level at 240V [dB]	48 - 59
Dimensions [mm]	W895 x D505 x H590 - 1030
Duct Diameter [mm]	Φ150
RCP	WM RM2,598 EM RM2,798

* 4 years general warranty for motor and parts.

-FUJIOH-

GAS HOB /

FH-GS70

ふたつの炎、
ダブルの幸せ。



Flexible
Installation



Triple Ring
Burner



Sectional
Flame
Control



Toughened
Glass



Heat
Deflector



Double
Inner
Flame



Instant
Ignition



Flame
Failure
Safety
Device



Aluminium
Alloy
Venturi



Scan QR Code to
watch the product
video.

ADVANCED FUNCTIONS



01 / Double Inner Flame

Improved heat distribution
ensures evenness.



02 / Aluminium Alloy Venturi

Rust-resistant aluminium alloy.



03 / Heat Deflector

Minimize thermal heat on
plate and knobs.

SPECIFICATIONS

FH-GS7020 SVGL



Surface Type
Black Glass (Toughened Glass)

Power Load [kW]
(L) 4.5 (R) 5.0

Dimensions [mm]
W780 x D460 x H171

Cut-Out Dimensions [mm]
W650 - 720 x D350 - 410 x H85

RCP
WM RM2,098 EM RM2,298

FH-GS7030 SVGL



Surface Type
Black Glass (Toughened Glass)

Power Load [kW]
(L) 4.5 (R) 5.0 (C) 1.1

Dimensions [mm]
W880 x D520 x H171

Cut-Out Dimensions [mm]
W700 - 800 x D400 - 430 x H85

RCP
WM RM2,598 EM RM2,798

* 2 years general warranty.

-FUJIOH-

GAS HOB /

FH-GS20

あなたの料理を支える、
洗練されたパートナー。



Flame
Failure
Safety
Device



Aluminium
Alloy
Venturi



Toughened
Glass



Instant
Ignition



Flexible
Installation



Gas Hob



ADVANCED FUNCTIONS



01 / Flame Failure Safety Device

Automatically shuts off gas when flame extinguishes for safety.



02 / Aluminium Alloy Venturi

Rust-resistant aluminium alloy.



03 / Flame Control

Control desired flame with both rings for different cuisines.

SPECIFICATIONS

FH-GS2020 SVGL



Surface Type
Black Glass (Toughened Glass)

Power Load [kW]
(L) 5.0 (R) 5.0

Dimensions [mm]
W730 x D420 x H153

Cut-Out Dimensions [mm]
W650 - 655 x D350 - 355 x H85

RCP
WM RM1,098 EM RM1,298

FH-GS2030 SVGL



Surface Type
Black Glass (Toughened Glass)

Power Load [kW]
(L) 5.0 (R) 5.0 (C) 1.0

Dimensions [mm]
W790 x D450 x H153

Cut-Out Dimensions [mm]
W685 - 690 x D405 - 410 x H85

RCP
WM RM1,398 EM RM1,598

* 2 years general warranty.

-FUJIOH-

GAS HOB /

FH-GS65

本格派の調理に。



Mini Pan Support (GS6520)



Instant Ignition



Flexible Installation



Triple Ring Burner



Flame Failure Safety Device



Aluminium Alloy Venturi



Sectional Flame Control



Toughened Glass (SVGL)



Heat Deflector



Matt Enamelled Pan Support



Brass Burner Cap



ADVANCED FUNCTIONS



01 / Heat Deflector

Minimize thermal heat on plate and knobs.



02 / Aluminium Alloy Venturi

Rust-resistant aluminium alloy.



03 / Sectional Flame Control

Ideal heat control with single or double flame rings.

SPECIFICATIONS

FH-GS6520 SVGL / SVSS



Surface Type
Black Glass (Toughened Glass) / Stainless Steel (SUS304)

Power Load [kW]
(L) 5.0 (R) 5.0

Dimensions [mm]
W780 x D460 x H155

Cut-Out Dimensions [mm]
W650 - 730 x D350 - 410 x H85

RCP
WM RM1,798 EM RM1,998

FH-GS6528 SVGL



Surface Type
Black Glass (Toughened Glass)

Power Load [kW]
(L) 5.0 (R) 5.0

Dimensions [mm]
W880 x D520 x H155

Cut-Out Dimensions [mm]
W690 - 830 x D390 - 470 x H85

RCP
WM RM1,898 EM RM2,098

FH-GS6530 SVGL / SVSS



Surface Type
Black Glass (Toughened Glass) / Stainless Steel (SUS304)

Power Load [kW]
(L) 5.0 (R) 5.0 (C) 1.1

Dimensions [mm]
W880 x D520 x H155

Cut-Out Dimensions [mm]
W690 - 830 x D390 - 470 x H85

RCP
WM RM2,098 EM RM2,298

* 2 years general warranty.

-FUJIOH-

GAS HOB / FH-GS30

火力調整を、
滑らかに自在に。



Gas Hob



ADVANCED FUNCTIONS

SPECIFICATIONS



01 / Flexible Size

Adaptable cut-out for seamless integration.



02 / Removable Burner

Simplify cleaning and make maintenance easier.



03 / Knob Shields

Minimize thermal heat on plate and knobs.

FH-GS3020 SVGL



Surface Type
Black Glass (Toughened Glass)

Power Load [kW]
(L) 5.0 (R) 5.0

Dimensions [mm]
W780 x D460 x H160

Cut-Out Dimensions [mm]
W650 - 730 x D350 - 410 x H82

RCP
WM RM1,598 EM RM1,798

FH-GS3028 SVGL



Surface Type
Black Glass (Toughened Glass)

Power Load [kW]
(L) 5.0 (R) 5.0

Dimensions [mm]
W880 x D520 x H160

Cut-Out Dimensions [mm]
W690 - 830 x D390 - 470 x H82

RCP
WM RM1,698 EM RM1,898

FH-GS3030 SVGL



Surface Type
Black Glass (Toughened Glass)

Power Load [kW]
(L) 5.0 (R) 5.0 (C) 2.0

Dimensions [mm]
W880 x D520 x H160

Cut-Out Dimensions [mm]
W690 - 830 x D390 - 470 x H82

RCP
WM RM1,898 EM RM2,098

*2 years general warranty.

-FUJIOH-

ELECTRIC HOB /

FH-IC70

色とりどりの料理を、
パワフルな加熱で。

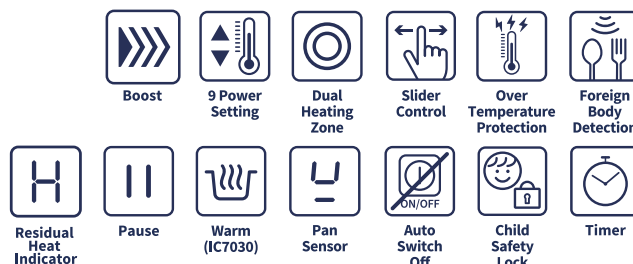

ADVANCED FUNCTIONS



01 / SCHOTT CERAN® Ceramic Glass

Sleek and durable glass surface.



02 / 2-in-1 Hybrid Hob

Blend induction speed and ceramic versatility in one.



03 / Dual Heating Zone

Flexible ceramic hob with adjustable heating zones.

SPECIFICATIONS

FH-IC7020



Type
Induction x 1 / Dual Zone Ceramic x 1

Rated Power Consumption [w]
(L) 2300 + (R) 2200
Total = max 4500

Surface Type
SCHOTT CERAN® Ceramic Glass

Zone Size [mm]
(L) 200 / (R) 138 - 230

Timer [min] 99

Ampere required [A] (Based on 240V)
20

Dimensions [mm] W730 x D430 x H64

Cut-Out Dimensions [mm]
W680 x D380

RCP WM RM2,198 EM RM2,398

FH-IC7030



Type
Induction x 2 / Dual Zone Ceramic x 1

Rated Power Consumption [w]
(L) 2300 + (C) 2000 = max 3500
(R) 2000
Total = max 5500

Surface Type
SCHOTT CERAN® Ceramic Glass

Zone Size [mm]
(L) 180 / (C) 180 / (R) 120 - 200

Timer [min] 99

Ampere required [A] (Based on 240V)
25

Dimensions [mm] W730 x D430 x H76

Cut-Out Dimensions [mm]
W695 x D410

RCP WM RM2,498 EM RM2,698

* 2 years general warranty.

-FUJIOH-

ELECTRIC HOB /

FH-ID5120/25/5230

美しさと、
機能性の融合。

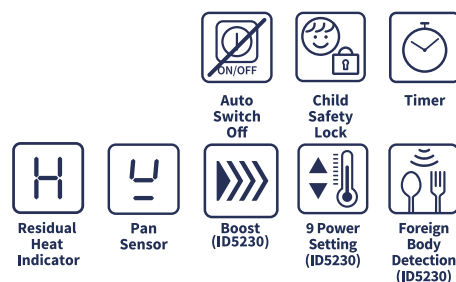

Electric Hob

SPECIFICATIONS

FH-ID5125



Type Induction Hob x 2

Rated Power Consumption [w]
(F) 1500 + (B) 2000
Total = max 3500

Surface Type
SCHOTT CERAN® Ceramic Glass

Zone Size [mm] (F) 150 / (B) 180

Timer [min] 99

Ampere required [A] (Based on 240V) 15

Dimensions [mm]
W288 x D520 x H60

Cut-Out Dimensions [mm]
W268 x D500

RCP WM RM1,598 EM RM1,798

FH-ID5120

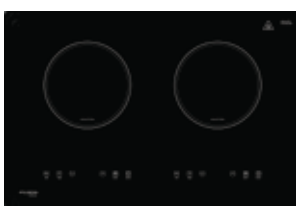

Type Induction Hob x 2

Rated Power Consumption [w]
(1500 - 2000) x 2
Total = max 3500

Surface Type
SCHOTT CERAN® Ceramic Glass

Zone Size [mm] (L) 190 / (R) 190

Timer [min] 180

Ampere required [A] (Based on 240V) 15

Dimensions [mm]
W650 x D430 x H65

Cut-Out Dimensions [mm]
W570 x D375

RCP WM RM1,798 EM RM1,998

FH-ID5230



Type Induction Hob x 3

Rated Power Consumption [w]
(F) 1500 + (B) 2600 + (R) 3000
Total = max 6600

Surface Type
SCHOTT CERAN® Ceramic Glass

Zone Size [mm] (F) 160 / (B) 210 / (R) 290

Timer [min] 99

Ampere required [A] (Based on 240V) 30

Dimensions [mm]
W590 x D520 x H62

Cut-Out Dimensions [mm]
W560 x D490

RCP WM RM2,198 EM RM2,398

* 2 years general warranty.

-FUJIOH-

OVEN /

FV-EL61/63

賢く優しいオーブンで、
安心調理と簡単お掃除。

- Dual Cooling Fan
- Accessories (EL63)
- Child Safety Lock
- Triple Layered Glass
- Enamel Coating
- Seamless Cavity
- Auto Cooking (EL63)
- Accessories (EL61)
- 70L Cavity Capacity (EL61)
- Meat Probe (EL63)
- 72L Cavity Capacity (EL63)
- Telescopic Rail (EL63)
- Soft Close (EL63)

FUNCTIONS

- Defrost
- Radiant Heat
- Convection #
- Drying #
- Dough Proving #
- Bottom Heat
- Double Grill
- Pizza #
- Keep Warm #
- Sabbath Mode #
- Conventional
- Double Grill + Fan
- Slow cooking #
- Plate Warm #
- Meat Probe #
- Conventional + Fan
- ECO

Available only in FV-EL63



(EL61)



(EL63)

Scan QR Code to
watch the product
video.

ADVANCED FUNCTIONS



Enamel Coated Cavity

Durable and easy for cleaning and maintenance.



Triple Layered Glass

Lessen heat on the glass door.



Telescopic Rails#

Effortlessly slide and access oven trays.



ACCESSORIES



Meat Probe#



Wire Rack

Enamel Baking Tray

Deep Enamel Baking Tray

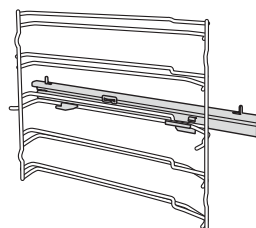

Telescopic Rails# x2

Available only in FV-EL63

SPECIFICATIONS

FV-EL61



FV-EL63



Type Built-In Oven	Layered of Glass 3
Capacity [L] 70	Cavity Material Enamel Coating
No. of Functions 8	Ampere required [A] (Based on 240V) 15
Rated Power Consumption [w] 3000	Gross Dimensions [mm] W595 x D575 x H595
Temperature Range [°C] 50-250	Cut-Out Dimensions [mm] W562 x D570 x H590
RCP WM RM2,498 EM RM2,698	

Type Built-In Oven	Layered of Glass 3
Capacity [L] 72	Cavity Material Enamel Coating
No. of Functions 17	Ampere required [A] (Based on 240V) 15
Rated Power Consumption [w] 2900	Gross Dimensions [mm] W595 x D566 x H596
Temperature Range [°C] 30 - 250	Cut-Out Dimensions [mm] W562 x D570 x H590
RCP WM RM5,498 EM RM5,698	



Oven

* 2 years general warranty.

-FUJIOH-

OVEN /

FV-EL62

多才なオーブンを味方に、
暮らしを楽しみに。

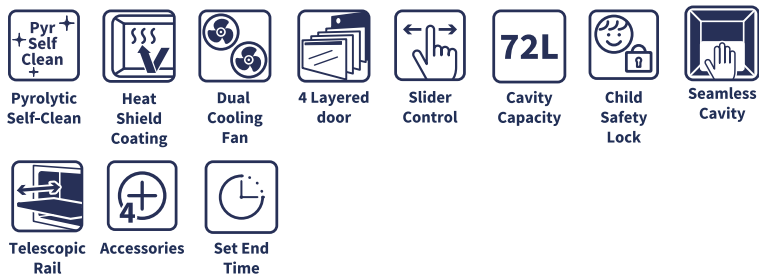

Scan QR Code to
watch the product
video.

FUNCTIONS

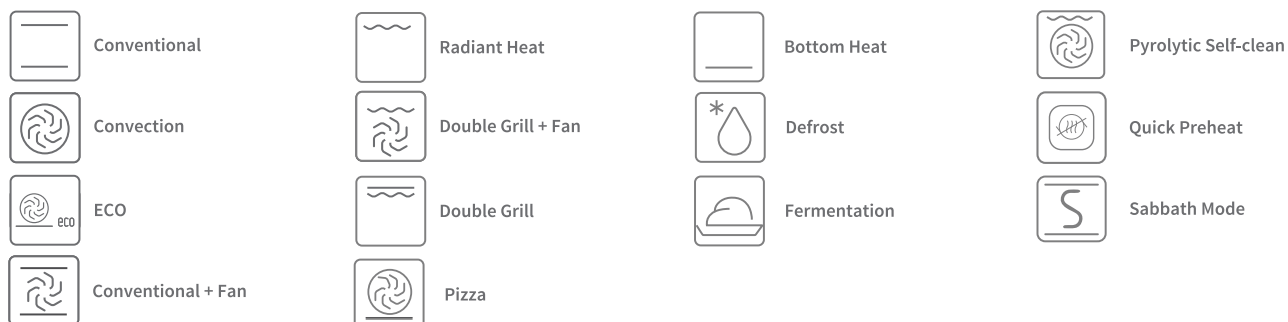

ADVANCED FUNCTIONS

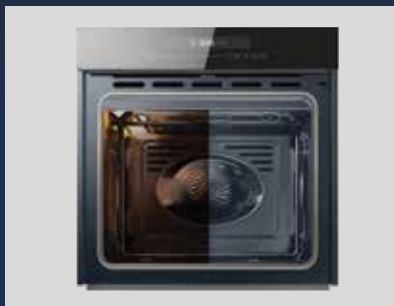

Pyrolytic Self-Clean

Burns off residues at 445°C
for easy wipe-cleaning.

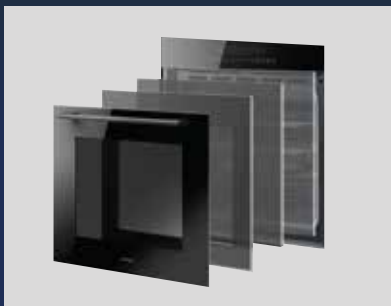

Cool-Touch 4 Layered Glass

Lessen heat on the
glass door.



Heat Shield Coating

Preserves oven's internals
from high temperatures.



SPECIFICATIONS

FV-EL62



Type Built-In Oven	Layered of Glass 4
Capacity [L] 72	Cavity Material Heat Shield Coating
No. of Functions 14	Ampere required [A] (Based on 240V) 15
Rated Power Consumption [w] 3200	Gross Dimensions [mm] W595 x D565 x H595
Temperature Range [°C] 30 - 250	Cut-Out Dimensions [mm] W560 x D550 x H590
RCP WM RM4,498 EM RM4,698	

ACCESSORIES



Wire Rack

Enamel Baking Tray

Deep Enamel Baking Tray

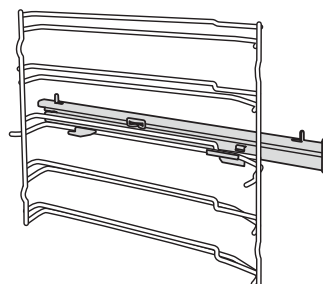

Telescopic Rail



Oven

* 2 years general warranty.

-FUJIOH-

COMBI OVEN /

FV-ML71

充実スチームとベイク、
多彩な機能を1台に。



1.2L Built-in
Water Tank



Auto
Cooking



Triple
Layered
Glass



SUS
304
Cavity



Child
Safety
Lock



Accessories



45L
Cavity
Capacity



Scan QR Code to
watch recipe
videos

ADVANCED FUNCTIONS



01 / Steam, Bake and Grill
Offer a wide range of possibilities.



02 / SUS 304 Cavity
Durable and rust-resistant
cooking space.



03 / Triple Layered Glass
Reduce heat transfer with one
low-E glass layer.

SPECIFICATIONS

FV-ML71



Type Combi Oven Steam, Bake & Grill	Layered of Glass 3
Capacity [L] 45	Cavity Material Stainless Steel (SUS304)
No. of Functions 10	Ampere required [A] (Based on 240V) 13
Rated Power Consumption [w] 2200	Gross Dimensions [mm] W597 x D480 x H454
Temperature Range [°C] 35-110 (Steam), 35-250 (Grill)	Cut-Out Dimensions [mm] W560 x D550 x H450
RCP WM RM5,798 EM RM5,998	

* 2 years general warranty.

-FUJIOH-

MICROWAVE OVEN /

FV-MW51

充実した機能と、
キッチンに寄り添うデザイン。



Grill



Electric
Door
Opening



Auto
Cooking



Seamless
Cavity



Child
Safety
Lock



Accessories



25L
Cavity
Capacity



Scan QR Code to
watch the product
video.



Oven

ADVANCED FUNCTIONS



01 / Grill Function

Explore diverse grilled cuisine.



02 / 8 Auto Cook Menu

Ideal time & temperature for
optimum food quality.



03 / Electric Door Opening

Swift door opening with
one touch.

SPECIFICATIONS

FV-MW51



Type	Layered of Glass
Microwave Oven	2
Microwave + Grill	
Capacity [L]	Cavity Material
25	Stainless Steel (SUS304)
Power Level	Ampere required [A]
5	(Based on 240V)
	13
Rated Power Consumption [w]	Gross Dimensions [mm]
1450	W595 x D401 x H388
Temperature Range [°C]	Cut-Out Dimensions [mm]
-	W560 x D500 x H380

RCP WM RM1,998 EM RM2,198

* 2 years general warranty.

GAS HOB



FH-GS2020 SVGL
Cut-Out Dimension
650-655(W) x 350-355(D)



FH-GS2030 SVGL
Cut-Out Dimension
685-690(W) x 405-410(D)

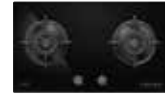

FH-GS3020 SVGL
Cut-Out Dimension
650 - 730(W) x D350-410(D)



FH-GS3028 SVGL
Cut-Out Dimension
690-830(W) x 390-470(D)

COOKER HOOD

FR-MS2390 V/R



RM2,488
RCP: RM2,796

RM2,788
RCP: RM3,096

RM2,988
RCP: RM3,296

RM3,088
RCP: RM3,396

FR-MT1990 V



RM3,488
RCP: RM3,996

RM3,788
RCP: RM4,296

RM3,788
RCP: RM4,496

RM3,888
RCP: RM4,596

FR-HT2190 V



RM3,088
RCP: RM3,696

RM3,388
RCP: RM3,996

RM3,388
RCP: RM4,196

RM3,488
RCP: RM4,296

FR-LT2290 V



RM3,488
RCP: RM3,996

RM3,788
RCP: RM4,296

RM3,788
RCP: RM4,496

RM3,888
RCP: RM4,596

FR-SD2290 V



RM3,788
RCP: RM4,496

RM4,088
RCP: RM4,796

RM4,188
RCP: RM4,996

RM4,288
RCP: RM5,096

FR-FS2290 VP/RP



RM4,188
RCP: RM4,896

RM4,488
RCP: RM5,296

RM4,588
RCP: RM5,396

RM4,688
RCP: RM5,496

FR-SC2090 V/R

With GFO Duct Cover/ RUT90 Recycle Panel



RM6,488
RCP: RM7,296

RM6,688
RCP: RM7,596

RM6,688
RCP: RM7,796

RM6,788
RCP: RM7,896

FR-ST2190 V



RM6,488
RCP: RM7,296

RM6,688
RCP: RM7,596

RM6,688
RCP: RM7,796

RM6,788
RCP: RM7,896

FR-CL1890 V/R



RM8,788
RCP: RM9,596

RM8,988
RCP: RM9,896

RM8,988
RCP: RM10,096

RM9,088
RCP: RM10,196

**FH-GS3030 SVGL**Cut-Out Dimension
690-830(W) x D390-470(D)**RM3,288**

RCP: RM3,596

**FH-GS6520 SVGL / SVSS**Cut-Out Dimension
650-730(W) x 350-410(D)**RM3,188**

RCP: RM3,496

**FH-GS6528 SVGL**Cut-Out Dimension
690-830(W) x 390-470(D)**RM3,288**

RCP: RM3,596

**FH-GS6530 SVGL / SVSS**Cut-Out Dimension
690-830(W) x 390-470(D)**RM3,488**

RCP: RM3,796

**FH-GS7020 SVGL**Cut-Out Dimension
650-720(W) x 350-410(D)**RM3,688**

RCP: RM3,796

**FH-GS7030 SVGL**Cut-Out Dimension
700-800(W) x 400-430(D)**RM3,988**

RCP: RM4,296

RM4,088

RCP: RM4,796

RM3,988

RCP: RM4,696

RM4,088

RCP: RM4,796

RM4,288

RCP: RM4,996

RM4,488

RCP: RM4,996

RM4,788

RCP: RM5,496

RM3,688

RCP: RM4,496

RM3,588

RCP: RM4,396

RM3,688

RCP: RM4,496

RM3,888

RCP: RM4,696

RM3,988

RCP: RM4,696

RM4,488

RCP: RM5,196

RM4,088

RCP: RM4,796

RM3,988

RCP: RM4,696

RM4,088

RCP: RM4,796

RM4,288

RCP: RM4,996

RM4,488

RCP: RM4,996

RM4,788

RCP: RM5,496

RM4,488

RCP: RM5,296

RM4,388

RCP: RM5,196

RM4,488

RCP: RM5,296

RM4,688

RCP: RM5,496

RM4,888

RCP: RM5,496

RM5,188

RCP: RM5,996

RM4,888

RCP: RM5,696

RM4,788

RCP: RM5,596

RM4,888

RCP: RM5,696

RM5,088

RCP: RM5,896

RM5,288

RCP: RM5,896

RM5,588

RCP: RM6,396

RM6,988

RCP: RM8,096

RM6,888

RCP: RM7,996

RM6,988

RCP: RM8,096

RM7,188

RCP: RM8,296

RM7,288

RCP: RM8,296

RM7,588

RCP: RM8,796

RM6,988

RCP: RM8,096

RM6,888

RCP: RM7,996

RM6,988

RCP: RM8,096

RM7,188

RCP: RM8,296

RM7,288

RCP: RM8,296

RM7,588

RCP: RM8,796

RM9,288

RCP: RM10,396

RM9,188

RCP: RM10,296

RM9,288

RCP: RM10,396

RM9,488

RCP: RM10,596

RM9,588

RCP: RM10,596

RM9,888

RCP: RM11,096

Bundle

Prices above are applicable to WM only. Additional charge of RM200 is applicable to purchases in EM.
The above measurements are calculated in units of "mm".

ELECTRIC HOB



FH-ID5125
Cut-Out Dimension
268(W) x 500(D)



FH-ID5120
Cut-Out Dimension
570(W) x 375(D)



FH-ID5230
Cut-Out Dimension
560(W) x 490(D)



FH-IC7020
Cut-Out Dimension
680(W) x 380(D)

COOKER HOOD

FR-MS2390 V/R



RM3,188
RCP: RM3,296

RM3,388
RCP: RM3,496

RM3,688
RCP: RM3,896

RM3,688
RCP: RM3,896

FR-MT1990 V



RM4,188
RCP: RM4,996

RM4,288
RCP: RM4,696

RM4,588
RCP: RM5,096

RM4,588
RCP: RM5,096

FR-HT2190 V



RM3,788
RCP: RM4,196

RM3,788
RCP: RM4,396

RM4,188
RCP: RM4,796

RM4,188
RCP: RM4,796

FR-LT2290 V



RM4,188
RCP: RM4,496

RM4,288
RCP: RM4,696

RM4,588
RCP: RM5,096

RM4,588
RCP: RM5,096

FR-SD2290 V



RM4,588
RCP: RM4,996

RM4,688
RCP: RM5,196

RM4,988
RCP: RM5,596

RM4,988
RCP: RM5,596

FR-FS2290 VP/RP



RM4,988
RCP: RM5,396

RM5,088
RCP: RM5,596

RM5,388
RCP: RM5,996

RM5,388
RCP: RM5,996

FR-SC2090 V/R

With GFO Duct Cover/ RUT90 Recycle Panel



RM7,088
RCP: RM7,796

RM7,188
RCP: RM7,996

RM7,488
RCP: RM8,396

RM7,488
RCP: RM8,396

FR-ST2190 V



RM7,088
RCP: RM7,796

RM7,188
RCP: RM7,996

RM7,488
RCP: RM8,396

RM7,488
RCP: RM8,396

FR-CL1890 V/R



RM9,288
RCP: RM10,096

RM9,388
RCP: RM10,296

RM9,688
RCP: RM10,696

RM9,688
RCP: RM10,696



FH-IC7030
Cut-Out Dimension
695(W) x 410(D)

RM3,988
RCP: RM4,196

RM4,888
RCP: RM5,396

RM4,488
RCP: RM5,096

RM4,888
RCP: RM5,396

RM5,288
RCP: RM5,896

RM5,688
RCP: RM6,296

RM7,788
RCP: RM8,696

RM7,788
RCP: RM8,696

RM9,988
RCP: RM10,996

BUILT-IN OVEN



FV-EL61
70L Capacity
8 Functions

PWP
RM2,188
RCP: RM2,498



FV-EL62
72L Capacity
14 Functions
Pyrolytic Self-Clean

PWP
RM4,188
RCP: RM4,498



FV-EL63
72L Capacity
17 Functions
30 Auto Cook Menus

PWP
RM5,088
RCP: RM5,498

BUILT-IN COMBI OVEN



FV-ML71
45L Capacity
10 Functions
32 Auto Cook Menus

PWP
RM5,288
RCP: RM5,798

BUILT-IN MICROWAVE OVEN



FV-MW51
25L Capacity
Grill Functions
8 Auto Cook Menus

PWP
RM1,788
RCP: RM1,998

Bundle

Prices above are applicable to WM only. Additional charge of RM200 is applicable to purchases in EM. The above measurements are calculated in units of "mm".

HOOD /
FR-CL1890 V

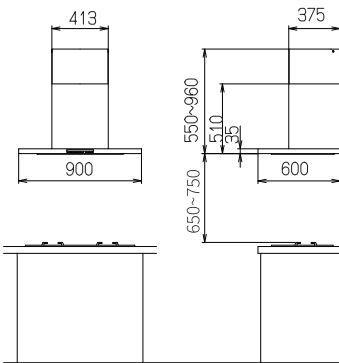

HOOD /
FR-CL1890 R

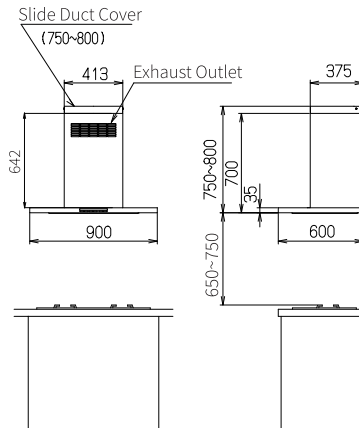

HOOD /
FR-SC2011 V

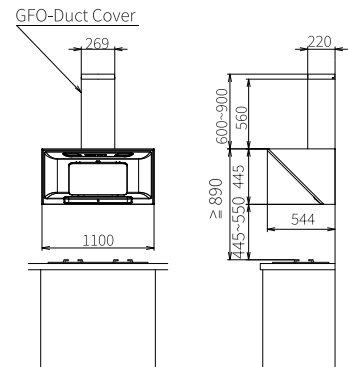

HOOD /
FR-SC2090 V

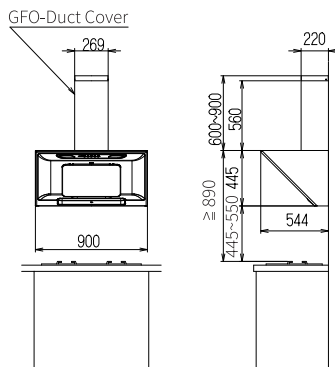

HOOD /
FR-SC2090 R

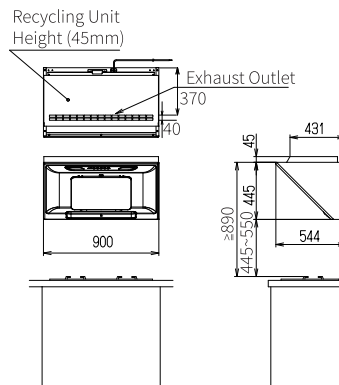

HOOD /
FR-ST2190 V

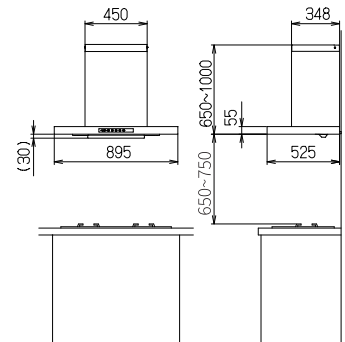

HOOD /
FR-FS2290 VP

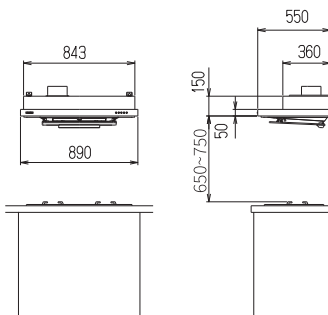

HOOD /
FR-FS2290 RP

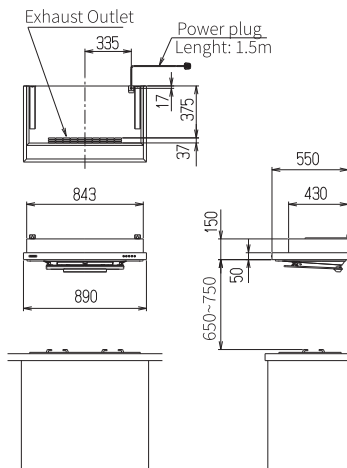

HOOD /
FR-MS2390 V

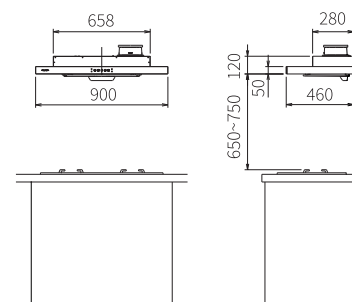

* The above measurements are calculated in units of "mm".

HOOD /
FR-MS2390 R

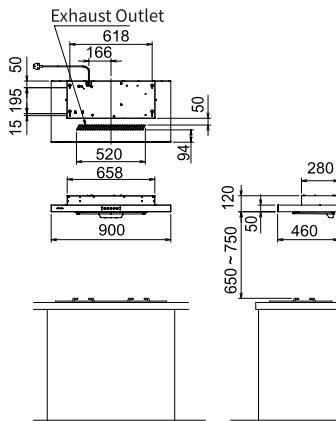

HOOD /
FR-SD2290 V

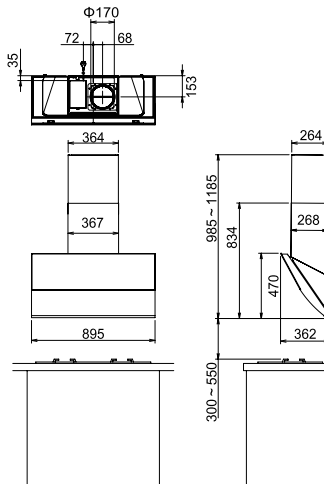

HOOD /
FR-LT2290 V

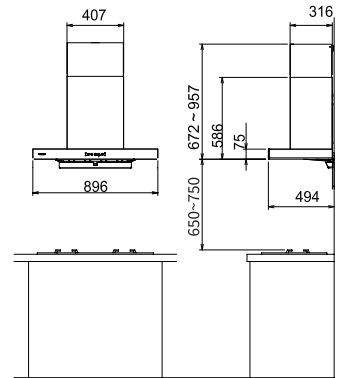

HOOD /
FR-MT1990 V

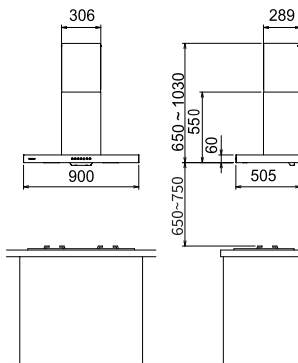

HOOD /
FR-HT2190 V

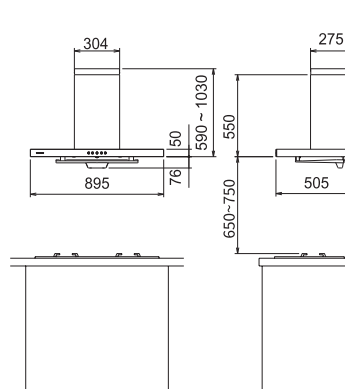

GAS HOB /
FH-GS7020 SVGL

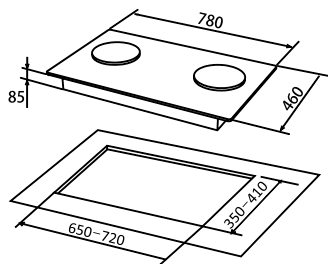

GAS HOB /
FH-GS7030 SVGL

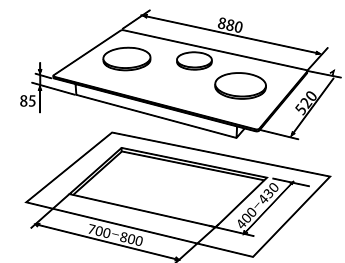

GAS HOB /
FH-GS6520 SVGL / SVSS

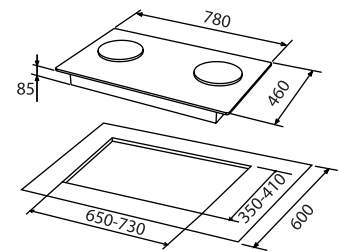

* The above measurements are calculated in units of "mm".

-FUJIOH-

GAS HOB /
FH-GS6528 SVGL

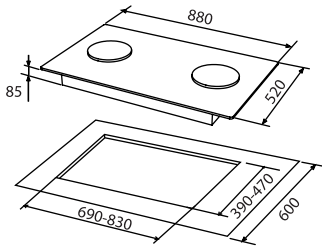

GAS HOB /
FH-GS6530 SVGL / SVSS

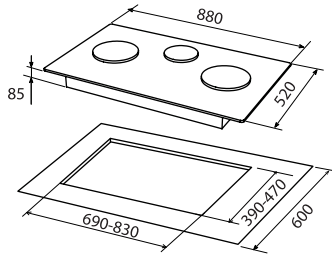

GAS HOB /
FH-GS3020 SVGL

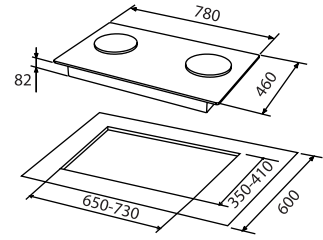

GAS HOB /
FH-GS3028 SVGL

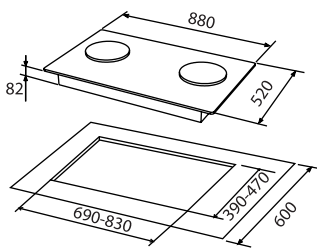

GAS HOB /
FH-GS3030 SVGL

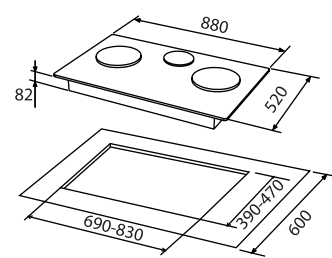

GAS HOB /
FH-GS2020 SVGL

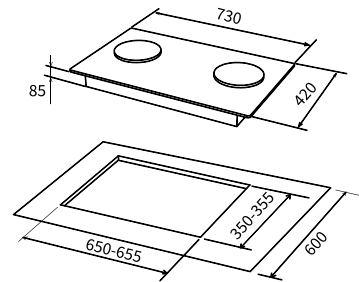

GAS HOB /
FH-GS2030 SVGL

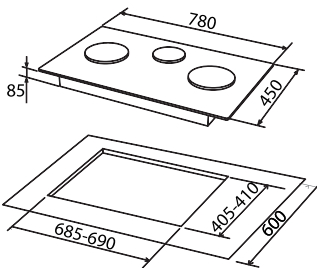

ELECTRIC HOB /
FH-IC7020

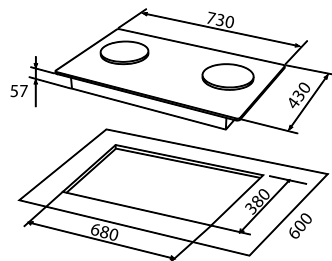

ELECTRIC HOB /
FH-IC7030

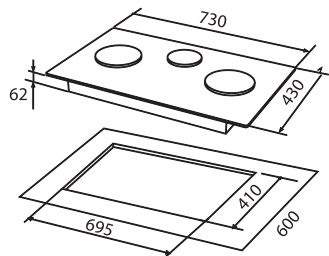

ELECTRIC HOB /
FH-ID5125

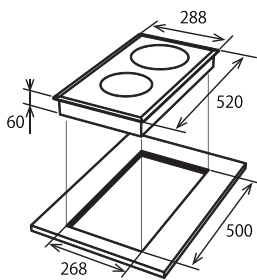

ELECTRIC HOB /
FH-ID5120

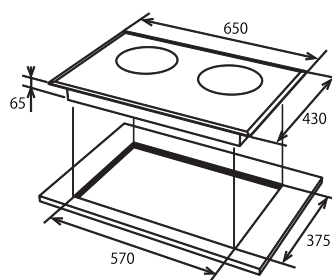

ELECTRIC HOB /
FH-ID5230

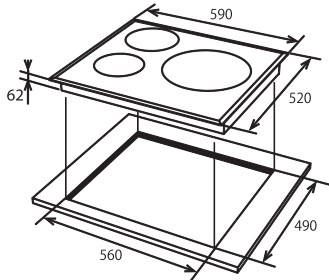

* The above measurements are calculated in units of "mm".

* Please ensure electric hob is well ventilated and the air inlet and outlet are not blocked.

-FUJIOH-

OVEN /
FV-EL63

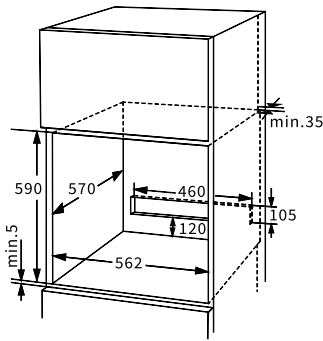
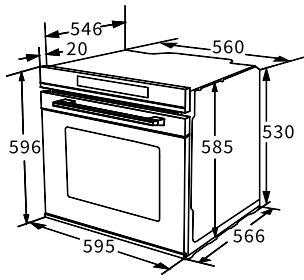

OVEN /
FV-EL62

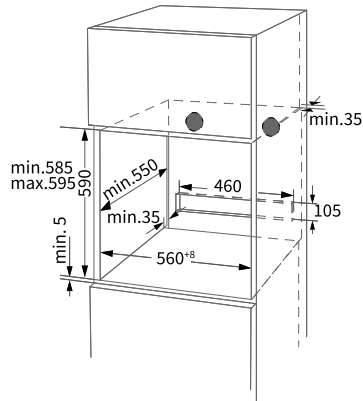
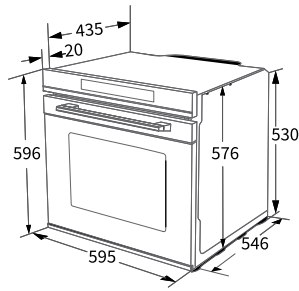

OVEN /
FV-EL61

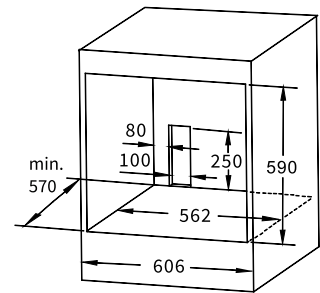
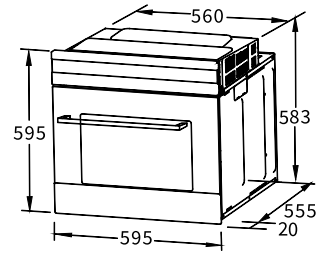

COMBI OVEN /
FV-ML71

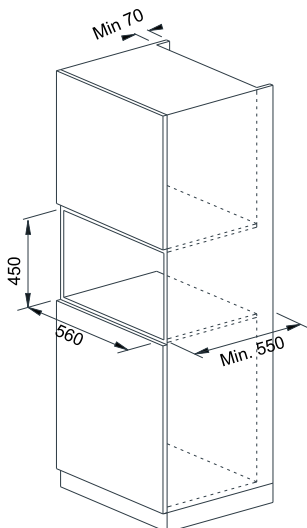
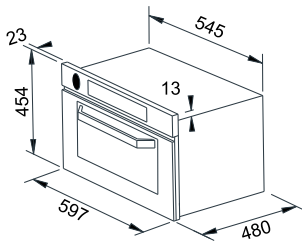

MICROWAVE OVEN /
FV-MW51

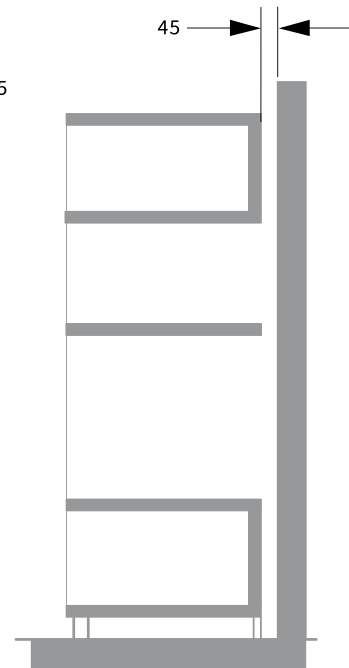
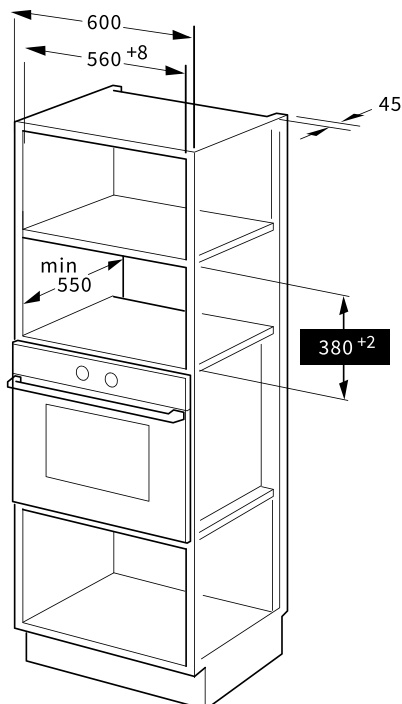

Back Ventilation Gap Allowance

* The above measurements are calculated in units of "mm".

* Product images are for illustrative purposes only and may differ from the actual product.

-FUJIOH-

FUJIOH MARKETING MALAYSIA SDN BHD

23, Jalan Serendah 26/39, Section 26,
40400 Shah Alam, Selangor, Malaysia.

For enquiries, please contact

✉ enquiry@fujioh.my

☎ 03- 5103 6826

www.fujioh.com/my



www.fujioh.com/my



Fujioh Malaysia



fujiohmy