

DE&E

SMART HOME





32 YEARS

**LEADING THE WAY
IN KITCHEN
APPLIANCE
TECHNOLOGY**

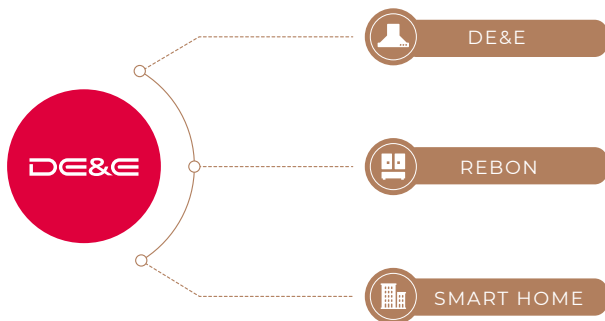

“

MOST ADVANCED INTELLIGENT FACTORY IN CHINA.

DE&E has been in the market since its establishment in 1992 and has always prioritized innovation, investing over 5% of sales turnover into product development annually. With a leading R&D center, DE&E has obtained over 260 patents and numerous international certificates. Their intelligent factory enables efficient control of production and after-sales service. DE&E has a strong brand presence with 80 agents, over 6,000 shops, and 3,000 exclusive stores nationwide. The DE&E experiencing centers showcase products in various real-life scenarios, enhancing the brand's reputation for its comprehensive, integral, simple, and fashionable design style.



CERTIFICATIONS

RoHS



REACH



CE

CB



Owing to the strict and complete quality control system, DE&E has got lots of international certificates, including CQC, RoHS, REACH, GS, PSA, KC, SASO, SAA, ISI, ETL, CE, CB and CCC on all hoods. The highest quality standard, fresh new original design and customer-oriented service have made DE&E a reliable partner for world famous brands for both OEM and ODM business.

DE&E'S HONOR



IF Design Award



Pin-up Asian Design Award



China Appliance Award 2019



Efficiency Purification Star



Red Star Design Award



China's Most Successful Designs Award



Intelligent Boosting

“Intelligent Boosting” is the strength of DE&E. DE&E has used countless original technologies and patents to lead the Chinese kitchen appliances industry for 32 years.

MAX12.0 High Wind Pressure Core Technology

DE&E developed “Intelligent boosting” series range hoods. With MAX10.0 high wind pressure core technology, it can change the speed of turbine automatically by using the full-sealed SP3.0 DC inverter motor. And the super large airflow can be up to 1250Pa.



As an OBM, we take pride in our ability to create and deliver high-quality products that embody our unique vision and values. By maintaining complete control over the entire production process, from design to manufacturing, we ensure that every product bearing our brand name meets the highest standards of quality, innovation, and craftsmanship. With our deep expertise and commitment to excellence, we strive to create memorable experiences for our customers and establish ourselves as a trusted and leading brand in the industry.



Be the first to experience our upcoming product by scanning the QR code provided. Stay tuned for more details and get ready to be amazed!



VIDEO
TUTORIALS



HT Q98

Highlight Feature



Intelligent Boosting Motor



60hrs Automatically Self-cleaning



Gesture Control



98% Grease Separation



Single-chambered Smoke Plate Air Inlet



3 Minutes Delay



190mm Ducting Hose



Round-chambered Air Inlet

- Unrestrained Airflow (m³/hr) : **2850m³/hr**
- Max Static Pressure (PA) : **1150PA**
- Rotation Per Minute : **2000 Rpm**
- Noise Level (db) : **52 dB**
- Type Of Motor : **Full Sealed Inverter DC Motor**
- Type Of Control : **3 speeds control**
- Grease Separation Rate : **98%**
- Odor Decrease Rate : **97%**
- Power supply : **262W**
- Dimension (W x D x H) (mm) : **895W x492D x720H**



HT968

Unrestrained Airflow (m3/hr) : 2750m³/hr
 Max Static Pressure (PA) : 1100PA
 Rotation Per Minute : 2200 Rpm
 Noise Level (db) : 50 dB
 Type Of Motor : Full Sealed Inverter DC Motor
 Type Of Control : 3 Speeds Control
 Grease Separation Rate : 98%
 Odor Decrease Rate : 97%
 Power supply : 262W
 Dimension (W x D x H) (mm) : 895W x 485D x 660H

Highlight Feature



- Intelligent Boosting Motor
- Intel RF Connection
- 60hrs Automatically Self-cleaning
- Nano-tech Integrally Formed
- Gesture Control
- 3 Minutes Delay
- 98% Grease Separation
- 190mm Ducting Hose
- Dual-chambered Smoke Plate Air Inlet



HT991

Unrestrained Airflow (m3/hr) : 2550m³/hr
 Max Static Pressure (PA) : 1000PA
 Rotation Per Minute : 1800 Rpm
 Noise Level (db) : 50 dB
 Type Of Motor : Full Sealed Inverter DC Motor
 Type Of Control : 3 speeds control
 Grease Separation Rate : 98%
 Odor Decrease Rate : 97%
 Power supply : 262W
 Dimension (W x D x H) (mm) : 895W x450D x580H

Highlight Feature



- Intelligent Boosting Motor
- Intel RF Connection
- 60hrs Automatically Self-cleaning
- Nano-tech Integrally Formed
- Gesture Control
- 3 Minutes Delay
- 98% Grease Separation
- 190mm Ducting Hose
- Single-chambered Smoke Plate Air Inlet
- Recirculation Mode





VIDEO
TUTORIALS





HA 939

Highlight Feature

 Intelligent Boosting Motor

 60hrs Automatically Self-cleaning

 Gesture Control 2.0

 98% Grease Separation

 Intel RF Connection

 3 Minutes Delay

 190mm Ducting Hose

 Recirculation Mode







- Unrestrained Airflow (m³/hr) : **2250m³/hr**
- Max Static Pressure (PA) : **920PA**
- Rotation Per Minute : **2000 Rpm**
- Noise Level : **54 dB**
- Type Of Motor : **Full Sealed Inverter DC Motor**
- Type Of Control : **unrestrict speed control**
- Grease Separation Rate : **98%**
- Odor Decrease Rate : **97%**
- Power Supply : **272W**
- Dimension (W x D x H) (mm) : **895W x 425D x 660H**



HA926

Unrestrained airflow (m³/hr) : 2050m³/hr
Max Static Pressure (PA) : 830PA
Rotation Per Minute : 1800 Rpm
Noise Level (db) : 55 dB
Type of Motor : Full Sealed Inverter DC Motor
Type Of Control : 3 Speeds Control
Grease Separation Rate : 98%
Odor Decrease Rate : 97%
Max Motor Power : 262W
Dimension (W x D x H) (mm) : 895W X 400D X 660H







Highlight Feature

-  Intelligent Boosting Motor
-  3 Minutes Delay
-  60hrs Automatically Self-cleaning
-  190mm Ducting Hose
-  Gesture Control
-  Recirculation Mode
-  98% Grease Separation

HA956

Unrestrained airflow (m³/hr) : 2750m³/hr
Max Static Pressure (PA) : 1100PA
Rotation Per Minute : 2000 Rpm
Noise Level (db) : 55 dB
Type of Motor : Full Sealed Inverter DC Motor
Type Of Control : 3 Speeds Control
Grease Separation Rate : 98%
Odor Decrease Rate : 97%
Max Motor Power : 262W
Dimension (W x D x H) (mm) : 895W X 400D X 660H

Highlight Feature

-  Intelligent Boosting Motor
-  3 Minutes Delay
-  60hrs Automatically Self-cleaning
-  190mm Ducting Hose
-  Gesture Control
-  98% Grease Separation
-  Intel RF Connection





S8669B

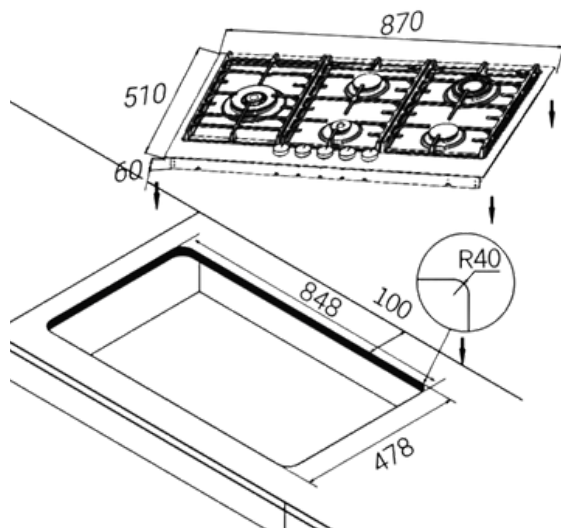

- Panel : 304 Stainless Steel (Flush in available)
- Burner Ring : SABAF (Made In Italy)
- Drip Pan : 304 Stainless Steel Finish
- Burner : ADC12
- Pan Support : Cast Iron in Enamel Finish
- Ignition : Battery (D Size)
- Flame Failure Devices : Spain Orkli
- Efficiency : 62%
- Power : 1 x 4.0kw, 1 x 3.0kw, 2 x 1.75kw, 1 x 1.0kw
- Gas Type : LPG / NG
- Product Size : 870 x 510 x 110 mm (W x D x H)
- Cut-out Size : 840 x 480 mm (W x D)



Sabaf Burner
Made in Italy



Spain Orkli
Microswitch



Spain Orkli
Safety Device

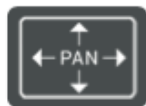

Easy Slide
Pan Support



4.0kW Power



Italian Feeling



Ultra-Slim



Sustainability focus

The 68% Advantage: Our stove's remarkable heat efficiency ensures consistent and even cooking temperatures, allowing you to create culinary masterpieces effortlessly.



4 Layers Temp-glass

A four-layer tempered glass hob offers durability, safety, even heat distribution, scratch resistance, easy cleaning, aesthetic appeal, longevity, and energy efficiency for your kitchen.

S7852i



Flexi Size

- Panel : 4 Layers Ultra Slim Tempered Glass
- Burner Ring : Brass
- Drip Pan : Cast Iron in Enamel Finish
- Burner : ADC12
- Pan Support : Cast Iron in Enamel Finish
- Ignition : Battery (D Size)
- Flame Failure Devices : Spain Orkli
- Efficiency : 68%
- Power : 2 x 5.2kw
- Gas Type : LPG / NG
- Product Size : 780 x 460 x 135 mm (W x D x H)
- Cut-out Size : 630-700 x 330-400 mm (W x D)

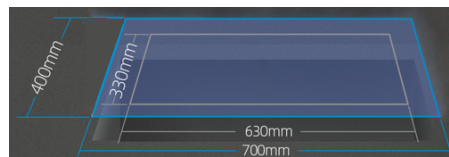

S7850i



Flexi Size

- Panel : 4 Layers Ultra Slim Tempered Glass
- Burner Ring : Brass
- Drip Pan : Cast Iron in Enamel Finish
- Burner : ADC12
- Pan Support : Cast Iron in Enamel Finish
- Ignition : Battery (D Size)
- Flame Failure Devices : Spain Orkli
- Efficiency : 68%
- Power : 2 x 5.2kw
- RF Connection
- Timer : 99 Minutes control for 2 burners
- Gas Type : LPG / NG
- Product Size : 780 x 460 x 135 mm (W x D x H)
- Cut-out Size : 630-700 x 330-400 mm (W x D)

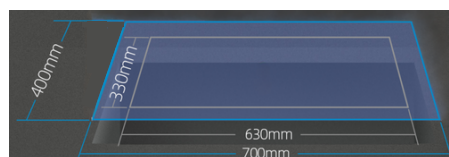

S8638

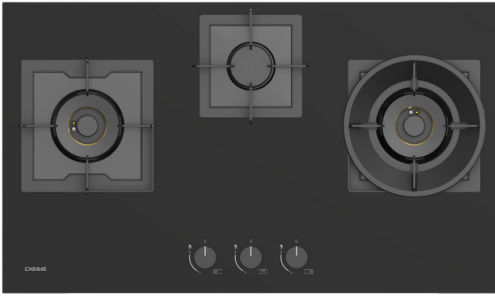

- Panel : 4 Layers Ultra Slim Tempered Glass
- Burner Ring : Brass
- Drip Pan : Cast Iron in Enamel Finish
- Burner : ADC12
- Pan Support : Cast Iron in Enamel Finish
- Ignition : Battery (D Size)
- Flame Failure Devices : Spain Orkli
- Efficiency : 68%
- Power : 2 x 5.2kw, 1 x 1.75kw
- Gas Type : LPG / NG
- Product Size : 870 x 510 x 110 mm (W x D x H)
- Cut-out Size : 830 x 470 mm (W x D)

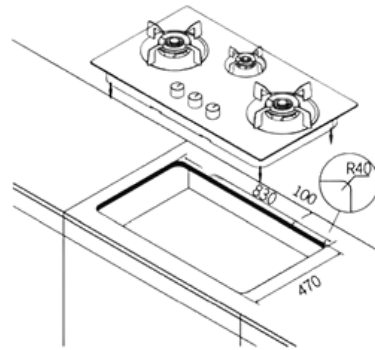

S7650



- Panel : Matte 304 Stainless Steel
- Burner Ring : Brass
- Drip Pan : Matte Stainless Steel Finish
- Burner : ADC12
- Pan Support : Cast Iron in Enamel Finish
- Ignition : Battery (D Size)
- Flame Failure Devices : Spain Orkli
- Efficiency : 68%
- Power : 2 x 5.2kw
- Gas Type : LPG / NG
- Product Size : 760 x 440 x 135 mm (W x D x H)
- Cut-out Size : 630 x 330 mm (W x D)

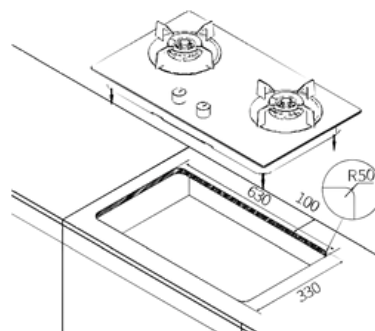

70L Steam & Grill Combi Oven ZK5770

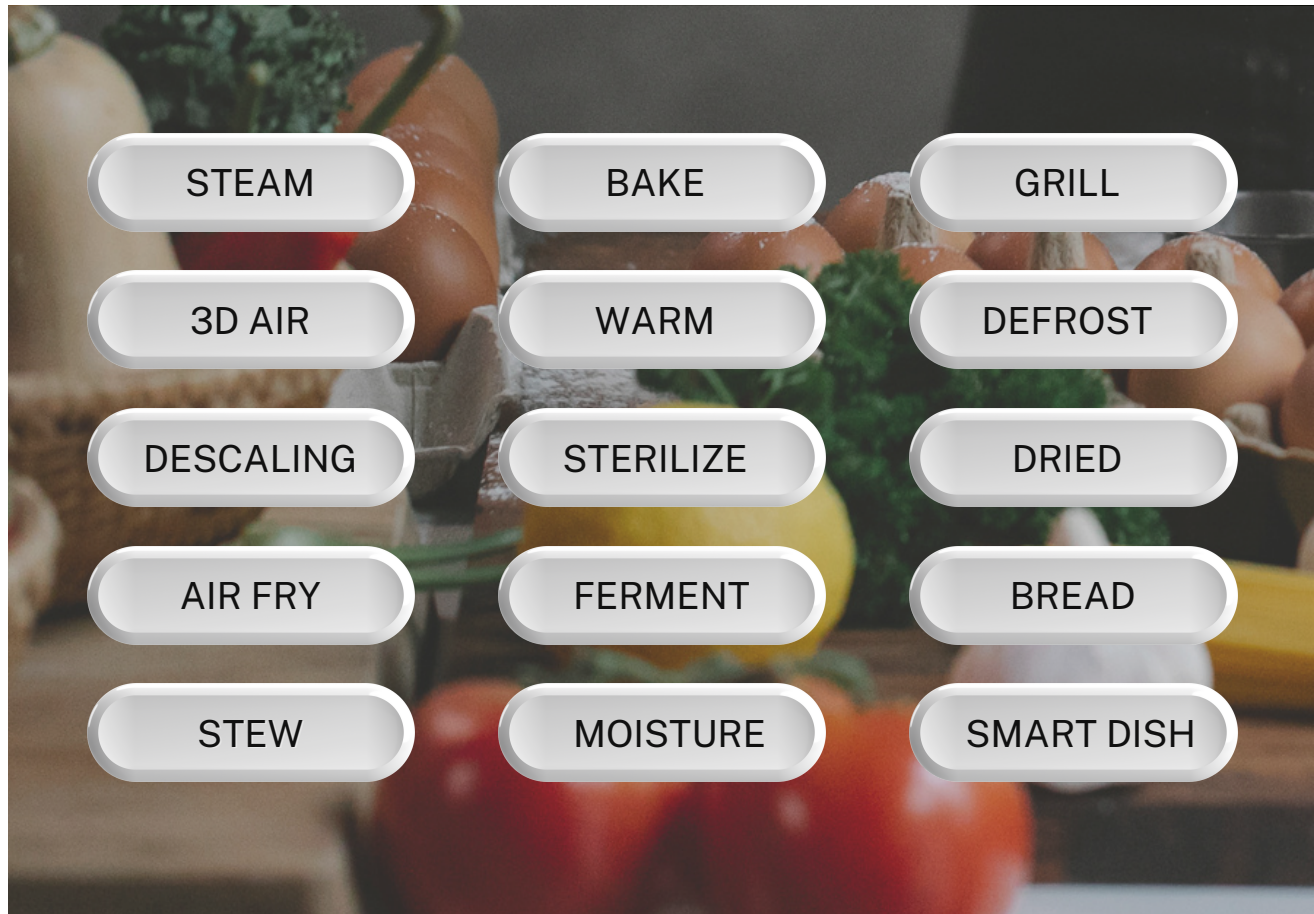

Retina TFT Panel

Equipped with a Retina dazzling touch screen, achieving optimal settings. The ZK5770 features a Retina dazzling touch screen, a high-quality display technology. It can provide finer image display effects such as brightness, contrast, saturation, and more. The result is clearer and brighter colors, making images more realistic and vibrant. This can offer users a more comfortable and enjoyable visual experience.

During use, different cooking modes, temperatures, and cooking durations can be quickly selected. During operation, the temperature inside the steamer oven cavity and the cooking status are easily visible.

Ceramic Cavity

Introducing the Ceramic Coat Inner Cavity – the perfect solution for effortless cleaning. With just one swipe, you can say goodbye to stubborn stains and food particles. Enjoy a better cavity, without the hassle.



Advanced Features Highlight

- TFT Panel: Equipped with a Retina dazzling touch screen, achieving optimal settings.
- Bilingual (English and Chinese) display capability.
- 12 cooking modes to meet various needs.
- DIY 3-stage cooking mode operation.
- Multiple chef-designed recipes to enhance the overall culinary experience.
- Moisture drying mode for effective evaporation of steam.
- Descaling mode to maintain steam freshness and food quality.
- Food probe with progress status indicator for precise cooking.
- Independent upper and lower temperature control for layered food textures.
- Two-level steam humidity adjustment.
- Innovative water tank: One-key automatic pop-up function and low water level reminder alert.



Steam & Grill Combi Oven ZK4585

- Function : 6+12 Functions
- Control Type : Fully Sensor Touch Control
- Cavity Material : High Grade Ceramic Enamel
- Panel Material : Tempered Glass
- Net Capacity : 45L
- Temperature : 30-120°C (Steam) / 30-230°C (Grill)
- Door : 3 Layer Tempered Glass
- Product Size : 595 x 520 x 455 (W x D x H) (mm)

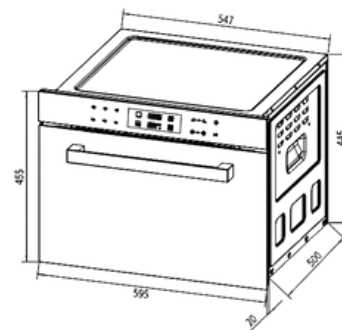

Steam Oven ZA4565A

- Function : 3+8 Functions With 30 Preset Menu
- Control Type : Fully Sensor Touch Control
- Cavity Material : High Grade Stainless Steel
- Panel Material : Tempered Glass
- Net Capacity : 45L
- Temperature : 30-120°C (Steam)
- Door : 3 Layer Tempered Glass
- Product Size : 595 x 520 x 455 (W x D x H) (mm)

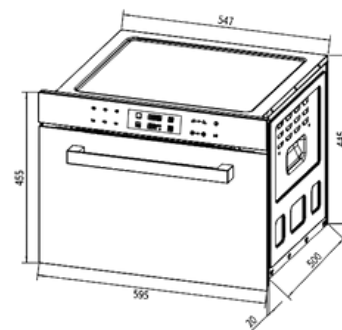

Compact Oven KA4505

- Function : 6+10 Functions
- Control Type : Fully Sensor Touch Control
- Cavity Material : High Grade Ceramic Enamel
- Panel Material : Tempered Glass
- Net Capacity : 45L
- Temperature : 30-260°C
- Door : 3 Layer Tempered Glass
- Product Size : 595 x 520 x 455 (W x D x H) (mm)

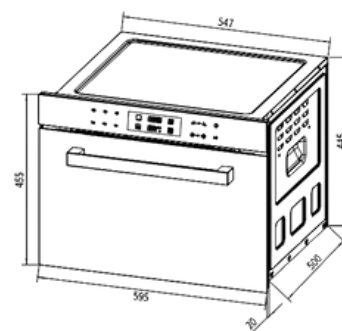



APPLIANCES WARRANTY



Warranty : Range Hood
Motor: 10 Years Warranty
General Parts : 3 Years Warranty



Warranty : Build-In Hob
Tempered Glass : 3 Years Warranty
General Parts : 2 Years Warranty



Warranty : Build-In Oven
Tempered Glass Door : 3 Years Warranty
General Parts : 2 Years Warranty

HTQ98

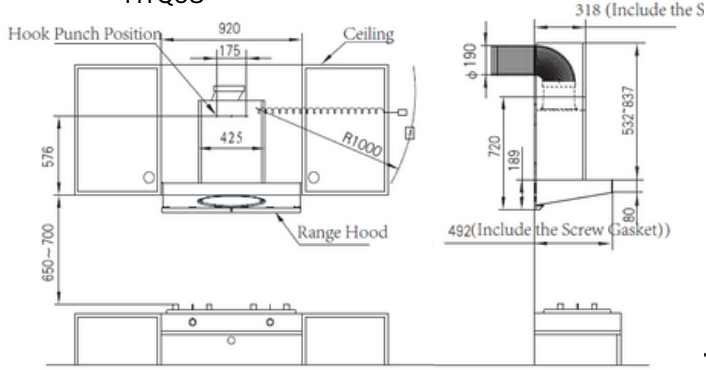

HA939

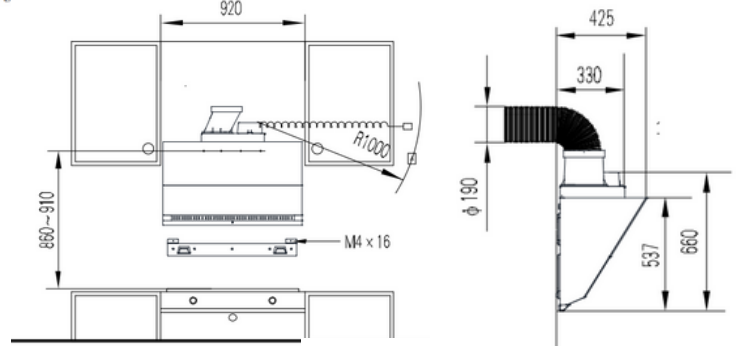

HT991

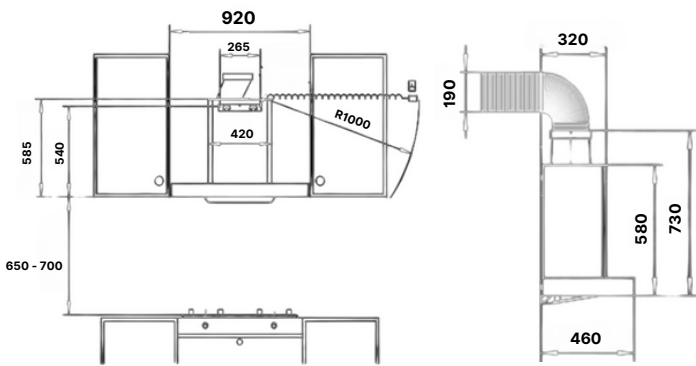

HA956

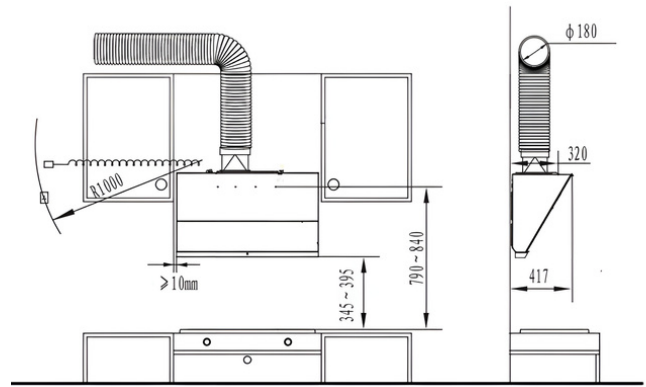

HT968

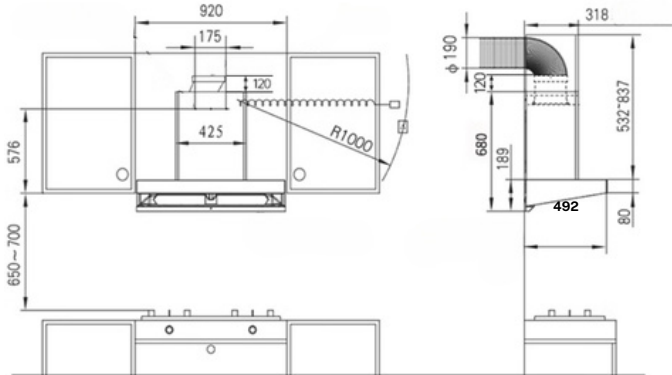

HA926

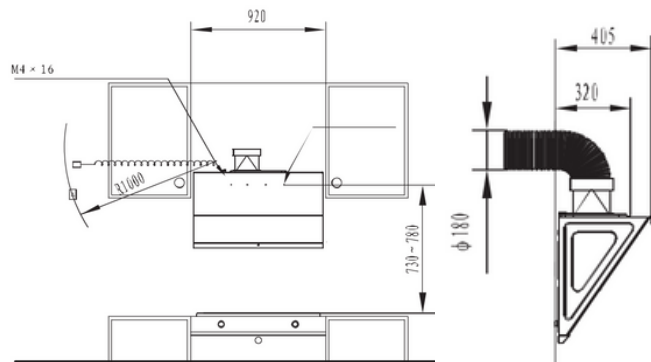

Imported by:



ST Glonet

R-03-23, Emporis, persiaran surian, Kota Damansara, 47810, PJ, Selangor

Tel: 03-7665 6563

Website: www.mysdee.com

Email: marketing@stglo.net

