



INSTANT WATER HEATER

REDEFINE THE WAY OF LIFE



REDEFINE THE WAY OF LIFE

Leading the change over the past 20 years

Rubine is the leading household appliances brand for the past 20 years with wide range of technologically advanced products with innovative designs.



Instant Water Heater With Rain Shower

Optimize your shower experience with our exceptional instant water heater and beautifully designed rain shower.

Product featured: RWH-IA991D-RCB

INNOVATION

Innovation is the core value of Rubine's ideology and fundamental in development of our unparalleled quality and durable products. All products are designed and built to the highest standards with newest innovations to ensure our products will always perform to the best and reflect the modern trends towards a better living environment.

QUALITY

Top quality, high functionality and irresistible elegance in our product designs, matched by our excellent post sales services are part of our 20 years' tradition. Our aspiration of "Redefine The Way Of Life" will promise to deliver unprecedented and satisfactory user experience.

EFFICIENCY

We employ groundbreaking technologies to develop energy-efficient household appliances to conserve the environment and to improve quality of life, for today and tomorrow.

**Instant Water Heater
With Chromed Hand Shower**
Our high quality water heater can always enhance your lifestyle and provide you with the best shower sensation.

Product featured: RWH-F191D-RMG



REDEFINE SHOWER EXPERIENCES

SHOWER LIFESTYLE CONCEPT

Our innovative technology with versatile functions on Rubine instant water heater and rain shower series will ensure your sensation, comfort, satisfaction and safety while redefining your shower experiences and lifestyle.



COMFORT

INNOVATION

SAFETY



OUR RECOGNITIONS



OUR WATER HEATER PUMP TYPES

Rubine's instant water heater comes in three types of pump : AC Pump, DC Pump and Non Pump. Pump type choices may varies depending on your living environment and preferred level of water pressure.

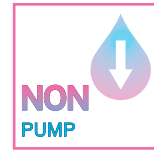

SILENT INVERTER DC PUMP

Eco-friendly DC Inverter Technology
 Less Power Energy Consumption
 Silent Operation with **<45dB**
 Maintenance-free
 (No carbon change needed)

LOW NOISE INVERTER AC PUMP

Inverter AC Booster Pump
 Decreases Carbon Loss
 Lower Operation Noise with **<60dB**
 (Compare to normal AC)

NON PUMP

Easy and User-friendly
 Quality and Affordable

INSTALLATION RECOMMENDATIONS INSTANT WATER HEATER PUMP / NON PUMP MODEL

Installation recommendations and methods to choose water heater pump or non pump model for optimum shower experiences:

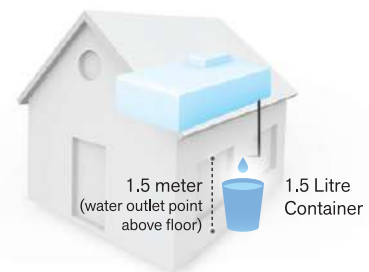

SINGLE STOREY, DOUBLE STOREY AND LOW RISE BUILDING

Water heaters with AC or DC pump are recommended.
 *Non pump water heater only if direct water supply from main pipe with strong water pressure.

MEASURE TIME TAKEN TO FILL UP WATER IN A 1.5 LITRE CONTAINER

Water heater with pump	: < 16 seconds
Non pump water heater	: > 16 seconds

*Results may varies subject to size and distance of pipe from water tank that may affect the water pressure.

COMFORT

Prioritize your comfort showering experiences with our sophisticated design and exceptional functions.



LOW NOISE INVERTER AC PUMP

Inverter AC Technology gives you extra benefits of stronger water flow with lower operation noise as compared to conventional AC pump.



LOW NOISE OPERATION

With low noise operation of <60db, you can now enjoy powerful and relaxed showering experiences.



STRONG WATER FLOW

AC Booster Pump creates strong water flow up to +/- 5 litre per minute.



LOW BRUSH LOSSES

The AC booster pump with new innovative technology will stabilize current, minimize sparking and decrease carbon loss. With this technology, AC booster pump will have a longer lifespan compared to normal AC pump.



SILENT INVERTER DC PUMP

The Inverter DC technology reduce energy usage and power consumption while maintaining silent operation for the best shower pleasure. DC pump offers longer lifespan, you can get more uses out of it, thus more saving in long run.



ECO-FRIENDLY

Longer life span with low power consumption, you can have a greener lifestyle with enjoyable shower.



SILENT OPERATION

The silent operation of DC Pump creates peaceful experience which is remarkably quiet at just **<45db**.



ENERGY SAVING

Save up to **60%** power and energy consumption compared to regular AC Pump.



MAINTENANCE FREE

DC pump uses magnet and brushless technology which makes it longer lasting and no carbon-change maintenance needed.

COMFORT



SLEEK STYLISH ELEGANT DESIGN

Rubine Instant Water Heater comes with variety of sleek and sophisticated design with splash proof protection (IP25 Standard) to secure and enhance a lavish lifestyle.



UL-APPROVED HIGH QUALITY UK TECHNOLOGY HEATING ELEMENT

Ensuring peace of mind with quality and reliable UL-approved heating element.

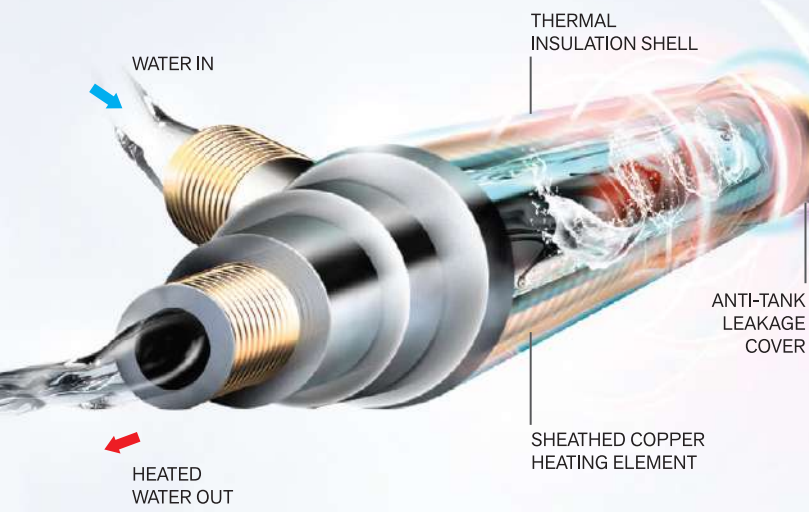

10 YEARS OF WARRANTY
Applicable on
Anti-Tank Leakage only.



7 YEARS OF WARRANTY
Applicable on
Heating Element only.

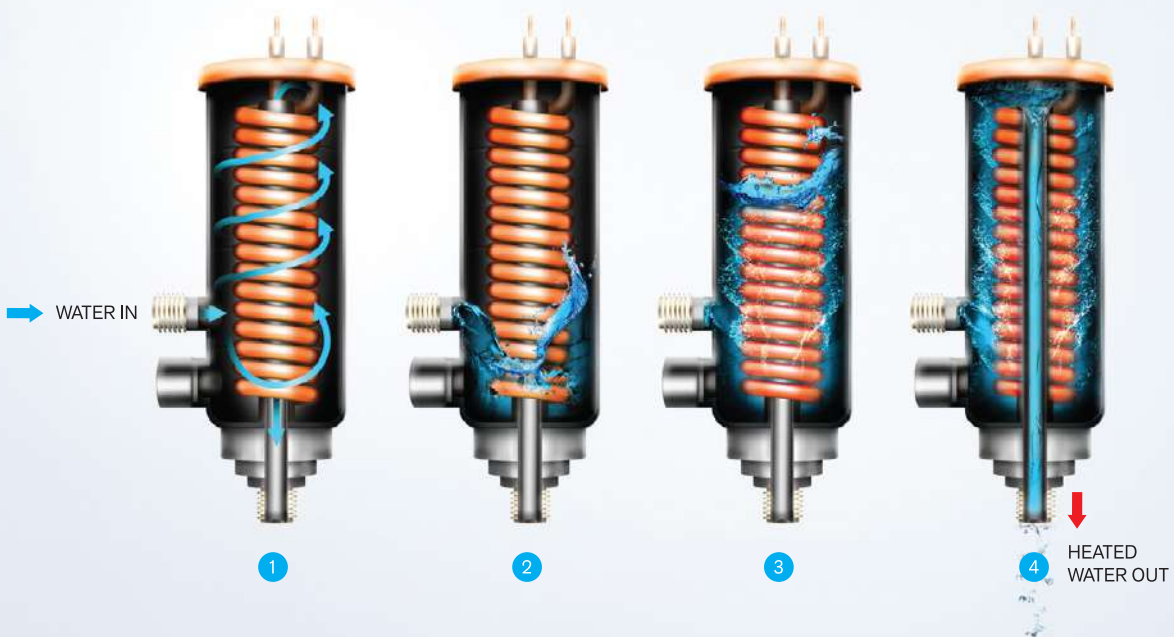

WATER HEATING PROCESS OF UL-APPROVED HIGH QUALITY UK TECHNOLOGY HEATING ELEMENT

INNOVATION

Adopting advanced innovations and transferring the technology into water heaters that is both efficient and ergonomic for all.



8.7"
EXTENDABLE
HEIGHT

180°
FULL
SWING



PLEASURE SHOWER IN FULL SWING

Shower bar is extendable up to additional of 8.7 inches and can be steadily swing for 180°, designed to fit any preferred position.

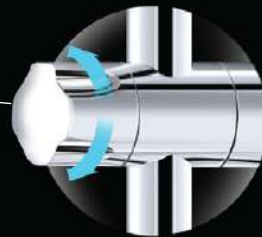

360° ANTI-BREAK ROTATING SHOWER HOLDER

200mm

ADJUSTABLE
ANGLE



ENJOYABLE SOOTHING SENSATION

The slim rain shower head with diameter of 200mm, comes in design that can be angled to your desired spot. A optimum 63-nozzles shower head, produces the best showering experiences.



EFFECTIVE ANTI-TWIST FLEXIBLE HOSE

The anti-twist hose prevents any loops or knots regardless how many times the shower head is twisted around.





RAIN SHOWER



HAND SHOWER



FAUCET



5 WAYS
HAND
SHOWER

3-IN-1 DIVERTER

All new 3-in-1 function diverter that allows you to switch between rain shower, hand shower and faucet pipe with just a twist of the knob.



WATER TO
RAIN
SHOWER

WATER IN

WATER TO
HAND
SHOWER

WATER TO
FAUCET
(NORMAL OR
WARM WATER)



MULTI-
USAGE
FAUCET

MULTIPLE USAGE FAUCET

Additional heated water outlet in your bathroom for various usage apart from showering.



EASY ACCESS OF
WARM AND NORMAL
TEMPERATURE
WATER OULET



WARM WATER
FOR HAND
WASH CLOTHES



WARM SHOWER
FOR BABY
BATHTUB



WARM SHOWER FOR
PET MADE EASY WITH
FAUCET INSTEAD OF
HANDHELD HAND
SHOWER HEAD

HAND SHOWER VARIATION

Rotate between power mist, wide spray, massage, full and combination spray pattern on hand shower for different usage.



1
MASSAGE



1 + 2
FULL SPRAY



2
WIDE SPRAY



2 + 3
COMBINATION



3
POWER MIST

SAFETY

Comply with safety assurances to protect you and your family. Giving a safe and relaxing shower sensation.



INNOVATIVE AUTO INSPECT ALARM

The extra safety built-in Auto Inspection Alarm, serves as a double protection that will check and detects malfunction on every use. The alarm will set off, if there is malfunction in ELCB or undetectable earth wire.

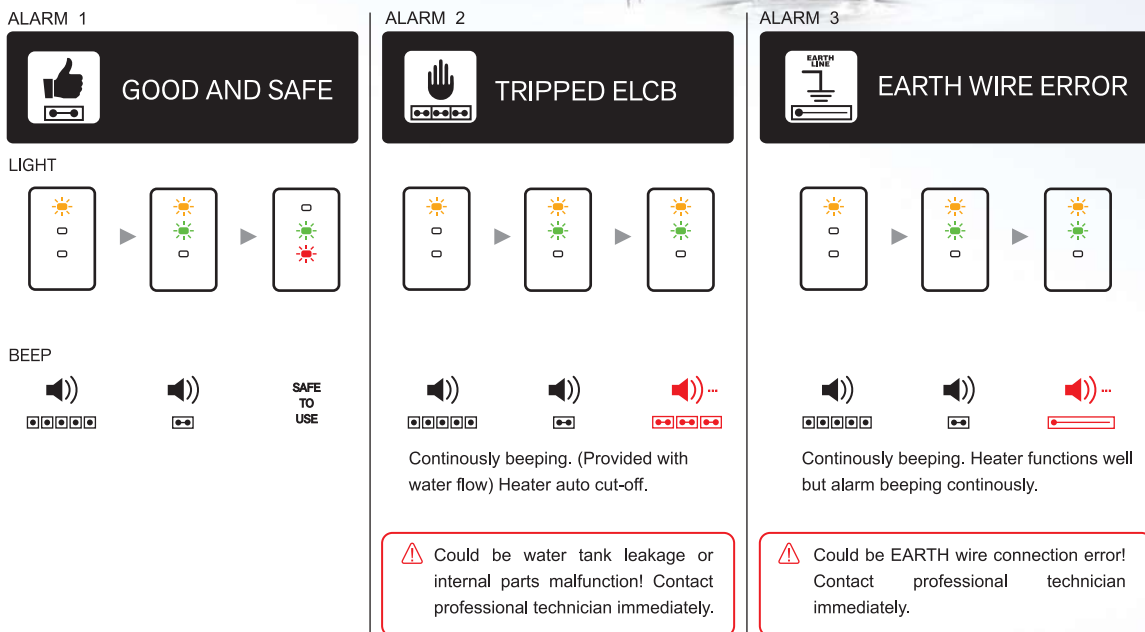

Safety Earth Wire Check Features:

Light On

Earth Wire - **Connected**

Blinking

Earth Wire - **Disconnected**



FORTE SERIES

EARTH WIRE INDICATOR

This safety indicator will ensure the earth wire connectivity & reliably earthed.

* Earth wire is to ground the excess current, should any leakage occur.



SPLASH PROOF CASE COVER WITH IEC INSULTED PROTECTION

Comply with IEC approved Splash Proof Protection (IP25 Standard) water-proof cover to avoid any water seepage into the heater.

* Always ensure proper seal installation for your safety.



EXTRA SAFETY DPDT PROTECTION SYSTEM

Double Thermal safety cut-off, ensure automatic halt to the temperature if it exceeds a certain point.

- 55°C Anti-scalding auto cut-off (Auto reset)
- 80°C Abnormal overheat cut-off (Manual reset is required)



Ⓐ When water flow in, the magnet will be elevated and activate the power sensor to turn on the heater set. (Reed Switch)

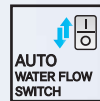

BUILT-IN AUTO WATER FLOW SWITCH

Automatically detects sufficient water pressure to operate to prevent dryburn.



Ⓑ When no water flow in, the magnet will remain and the heater set will not be activated. (Reed Switch)



COMPACT WATER FILTER & STOP VALVE

Equipped with a superior quality stop valve with built-in water filter to ensure better flow efficiency and filters out water particles.





INTELLIGENT AGENT (IA) SERIES



INNOVATIVE AUTO INSPECT ALARM



60% ENERGY SAVING
60% ENERGY SAVING APPLICABLE ON ECO-FRIENDLY SILENT INVERTER DC PUMP



3-IN-1 DIVERTER



SPLASH PROOF CASE COVER WITH IEC INSULATED PROTECTION



BUILT-IN AUTO WATER FLOW SWITCH



EXTRA SAFETY DPDT PROTECTION SYSTEM



COMPACT WATER FILTER & STOP VALVE



UL-APPROVED HIGH QUALITY HEATING ELEMENT TECHNOLOGY FROM UK



SILENT INVERTER DC PUMP



Power Rating	3.8kW 240V 50Hz
Min. Water Pressure	0.2 Bar
Min. Water Flow Rate	2ℓ / min
Inlet/Outlet Water Connector	ø15mm (1/2" BSP)
Temperature Control	Stepless Electronic
Pump Type	Inverter DC Silent Pump
Noise Level	<45db
Product Dimension (WxDxHmm)	225x84x375

With Rain Shower Set

CARBON BLACK	RWH-IA991D-RCB
METALLIC GREY	RWH-IA991D-RMG
MATTE PEWTER	RWH-IA991D-RMP

RCP WM **RM 969** / EM **RM 1,020**



With Chrome Accessories

CARBON BLACK	RWH-IA991D-CCB
METALLIC GREY	RWH-IA991D-CMG

RCP WM **RM 745** / EM **RM 784**



NON PUMP



Power Rating	3.8kW 240V 50Hz
Min. Water Pressure	0.2 Bar
Min. Water Flow Rate	2ℓ / min
Inlet/Outlet Water Connector	ø15mm (1/2" BSP)
Temperature Control	Stepless Electronic
Product Dimension (WxDxHmm)	225x84x375

With Chrome Accessories

METALLIC GREY	RWH-IA990N-CMG
----------------------	----------------

RCP WM **RM 445** / EM **RM 468**



SALVO SERIES



— STYLISH
STEPLESS
CONTROL

— FLOW, HEATER AND
EARTH WIRE INDICATOR

— ONE-PUSH
PUMP
CONTROL

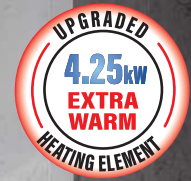

SALVO SERIES

**INVENTIVELY
DESIGNED WITH
INNOVATIVE
FEATURES**

SILKY SAND WITH CHAMPAGNE GOLD RAIN SHOWER SET RWH-S731D-GRSS



60% ENERGY SAVING
APPLICABLE ON
ECO-FRIENDLY SILENT
INVERTER DC PUMP



EARTH WIRE INDICATOR



FLOW INDICATOR



RESIDUAL-CURRENT CIRCUIT BREAKER (RCCB) DEVICE



3-IN-1 DIVERTER



SPLASH PROOF CASE COVER WITH IEC INSULATED PROTECTION



BUILT-IN AUTO WATER FLOW SWITCH



EXTRA SAFETY DPDT PROTECTION SYSTEM



COMPACT WATER FILTER & STOP VALVE



UL-APPROVED HIGH QUALITY HEATING ELEMENT TECHNOLOGY FROM UK



SILENT INVERTER DC PUMP



Power Rating	4.25kW 240V 50Hz
Min. Water Pressure	0.2 Bar
Min. Water Flow Rate	1.6ℓ / min
Inlet/Outlet Water Connector	ø15mm (1/2" BSP)
Temperature Control	Stepless Electronic
Pump Type	Inverter DC Silent Pump
Noise Level	<45db
Product Dimension (WxDxHmm)	235x89x380

With Champagne Gold Rain Shower Set



URBAN TITANIUM	RWH-S731D-GRUT
AEGEAN BLUE	RWH-S731D-GRAB
SILKY SAND	RWH-S731D-GRSS

RCP WM **RM 947** | EM **RM 997**



With Black Accessories

URBAN TITANIUM	RWH-S731D-BUT
AEGEAN BLUE	RWH-S731D-BAB

RCP WM **RM 662** | EM **RM 697**

SALVO SERIES



NON PUMP



Power Rating	4.25kW 240V 50Hz
Min. Water Pressure	0.2 Bar
Min. Water Flow Rate	1.6ℓ / min
Inlet/Outlet Water Connector	ø15mm (1/2" BSP)
Temperature Control	Stepless Electronic
Product Dimension (WxDxHmm)	235x89x380

With Black Accessories

URBAN TITANIUM RWH-S730N-BUT

RCP WM RM 433 | EM RM 456

☀ LED ON

⚡ LED OFF

FLOW LED INDICATOR

FLOW

Shower set installation & flow switch in order

- ⚠ ① Inlet & outlet installation in reverse
- or
- ⚠ ② Flow switch (internal) malfunction

HEATER LED INDICATOR

HEATER

Temperature on

Temperature off

EARTH WIRE INDICATOR

EARTH POWER

Earth wire connected

- ⚠ Earth wire disconnected (LED blinking)



SALVO SERIES

**MODERN
DESIGN WITH
HIGH QUALITY
TECHNOLOGY**

AEGEAN
BLUE

WITH CHAMPAGNE GOLD
RAIN SHOWER SET
RWH-S731D-GRAB

SALVO SERIES

LED INDICATOR

FLOW LED INDICATOR

FLOW

HEATER LED INDICATOR

HEATER

EARTH WIRE INDICATOR

EARTH POWER



SOPHISTICATED HAIRLINE FINISHING

Epitomizes our unwavering craftsmanship, meticulously perfecting each intricate detail to deliver unmatched quality and exquisite aesthetics

STYLISH
STEPLESS
CONTROL

ONE-PUSH
PUMP
CONTROL

PUMP

REVOLUTIONARY DESIGNED WITH HIGH QUALITY FUNCTION

URBAN
TITANIUM

WITH CHAMPAGNE GOLD
RAIN SHOWER SET
RWH-S731D-GRUT



RESIDUAL-CURRENT CIRCUIT BREAKER (RCCB) DEVICE

Automatically measures and disconnects the circuit when residual current occurs or current exceeds rated sensitivity.





CETUS SERIES

Cetus SERIES

REFRESHING
SHOWER EXPERIENCE
WITH 4.25kW POWER

CHAMPAGNE GOLD WITH RAIN SHOWER SET
RWH-CE521D-MRCG

POWER, HEATER
AND RCCB

STEPLESS
ELECTRONIC
CONTROL

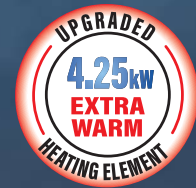

60% ENERGY SAVING
60% ENERGY SAVING APPLICABLE ON ECO-FRIENDLY SILENT INVERTER DC PUMP

RCCB DEVICE
RESIDUAL-CURRENT CIRCUIT BREAKER (RCCB) DEVICE

3-IN-1 DIVERTER
3-IN-1 DIVERTER

IP 25 PROTECTION
SPASH PROOF CASE COVER WITH IEC INSULATED PROTECTION

AUTO WATER FLOW SWITCH
BUILT-IN AUTO WATER FLOW SWITCH

EXTRA SAFETY
EXTRA SAFETY DPDT PROTECTION SYSTEM

COMPACT WATER FILTER STOP VALVE
COMPACT WATER FILTER & STOP VALVE

UL-APPROVED TECHNOLOGY
UL-APPROVED HIGH QUALITY HEATING ELEMENT TECHNOLOGY FROM UK



SILENT INVERTER DC PUMP

Power Rating	4.25kW 240V 50Hz
Min. Water Pressure	0.2 Bar
Min. Water Flow Rate	2ℓ / min
Inlet/Outlet Water Connector	ø15mm (1/2" BSP)
Temperature Control	Stepless Electronic
Pump Type	Inverter DC Silent Pump
Noise Level	<45db
Product Dimension (WxDxHmm)	205x87x440



With Matte Black Rain Shower Set

CHAMPAGNE GOLD RWH-CE521D-MRCG

IRON GREY RWH-CE521D-MRIG

SAND BLACK RWH-CE521D-MRSB

RCP WM **RM 920** / EM **RM 968**

With Black Rain Shower Set

CHAMPAGNE GOLD RWH-CE521D-SRCG

IRON GREY RWH-CE521D-SRIG

SAND BLACK RWH-CE521D-SRSB

RCP WM **RM 870** / EM **RM 916**

CETUS SERIES



SILENT INVERTER DC PUMP



Power Rating	4.25kW 240V 50Hz
Min. Water Pressure	0.2 Bar
Min. Water Flow Rate	2ℓ / min
Inlet/Outlet Water Connector	ø15mm (1/2" BSP)
Temperature Control	Stepless Electronic
Pump Type	Inverter DC Silent Pump
Noise Level	<45db
Product Dimension (WxDxHmm)	205x87x440

With Black Accessories

CHAMPAGNE GOLD	RWH-CE521D-SCG
SAND BLACK	RWH-CE521D-SSB

RCP WM **RM 635** / EM **RM 668**



NON PUMP



Power Rating	4.25kW 240V 50Hz
Min. Water Pressure	0.2 Bar
Min. Water Flow Rate	2ℓ / min
Inlet/Outlet Water Connector	ø15mm (1/2" BSP)
Temperature Control	Stepless Electronic
Product Dimension (WxDxHmm)	205x87x440

With Black Accessories

SAND BLACK	RWH-CE520N-SSB
-------------------	----------------

RCP WM **RM 409** / EM **RM 431**



LUXURY DESIGN WITH
MORE POWERFUL
FUNCTION



FORTE SERIES



FORTE SERIES

ENHANCING
YOUR
MODERN
BATHROOM

CARBON BLACK WITH RAIN SHOWER SET
RWH-F191D-RCB



60% ENERGY SAVING
APPLICABLE ON
ECO-FRIENDLY SILENT
INVERTER DC PUMP



3-IN-1 DIVERTER



SPLASH PROOF CASE
COVER WITH IEC
INSULATED PROTECTION



BUILT-IN AUTO
WATER FLOW
SWITCH



EXTRA SAFETY
DPDT
PROTECTION
SYSTEM



COMPACT
WATER FILTER &
STOP VALVE



UL-APPROVED HIGH
QUALITY HEATING
ELEMENT TECHNOLOGY
FROM UK

FORTE SERIES



SILENT INVERTER DC PUMP



Power Rating	3.8kW 240V 50Hz
Min. Water Pressure	0.2 Bar
Min. Water Flow Rate	2ℓ / min
Inlet/Outlet Water Connector	ø15mm (1/2" BSP)
Temperature Control	Stepless Electronic
Pump Type	Inverter DC Silent Pump
Noise Level	<45db
Product Dimension (WxDxHmm)	190x87x440

With Rain Shower Set

CARBON BLACK RWH-F191D-RCB

RCP WM **RM 925** / EM **RM 974**



With Black Accessories

CARBON BLACK RWH-F191D-BCB

RCP WM **RM 659** / EM **RM 694**



TRULY
COMFORTABLE
WITH QUALITY
ASSURED

SLIM SMART ELEGANT (SSE) SERIES



SLIM SMART
ELEGANT SERIES

ELEGANT WITH
HIGH QUALITY
PERFORMANCE

CARBON BLACK WITH RAIN SHOWER SET
RWH-SSE891D-RCB



60% ENERGY SAVING
APPLICABLE ON
ECO-FRIENDLY SILENT
INVERTER DC PUMP



LOW NOISE OPERATION
APPLICABLE ON LOW NOISE
INVERTER AC PUMP ONLY



2-IN-1 DIVERTER



SPLASH PROOF CASE COVER WITH IEC INSULATED PROTECTION



BUILT-IN AUTO WATER FLOW SWITCH



EXTRA SAFETY DPDT PROTECTION SYSTEM



COMPACT WATER FILTER & STOP VALVE



UL-APPROVED HIGH QUALITY HEATING ELEMENT TECHNOLOGY FROM UK



SILENT INVERTER DC PUMP



Power Rating	3.8kW 240V 50Hz
Min. Water Pressure	0.2 Bar
Min. Water Flow Rate	2ℓ / min
Inlet/Outlet Water Connector	ø15mm (1/2" BSP)
Temperature Control	Stepless Electronic
Pump Type	Inverter DC Silent Pump
Noise Level	<45db
Product Dimension (WxDxHmm)	190x87x440

With Rain Shower Set

CARBON BLACK	RWH-SSE891D-RCB
METALLIC GREY	RWH-SSE891D-RMG
MATTE PEWTER	RWH-SSE891D-RMP

RCP WM **RM 909** / EM **RM 957**



With Black Accessories

CARBON BLACK	RWH-SSE891D-BCB
---------------------	-----------------

RCP WM **RM 645** / EM **RM 679**

With White Accessories

MODERN WHITE	RWH-SSE891D-WMW
---------------------	-----------------

RCP WM **RM 619** / EM **RM 652**



LOW NOISE INVERTER AC PUMP



Power Rating	3.8kW 240V 50Hz
Min. Water Pressure	0.2 Bar
Min. Water Flow Rate	2ℓ / min
Inlet/Outlet Water Connector	ø15mm (1/2" BSP)
Temperature Control	Stepless Electronic
Pump Type	Inverter AC Booster Pump
Noise Level	<60db
Product Dimension (WxDxHmm)	190x87x440

With Black Accessories

CARBON BLACK	RWH-SSE892A-BCB
---------------------	-----------------

RCP WM **RM 585** / EM **RM 616**

With White Accessories

MODERN WHITE	RWH-SSE892A-WMW
---------------------	-----------------

RCP WM **RM 559** / EM **RM 588**



FLUSSO SERIES



FLUSSO SERIES

**PREMIERE
COMFORT
SHOWER
EXPERIENCES**

CARBON BLACK WITH RAIN SHOWER SET
RWH-FS391D-BRCB



60% ENERGY SAVING
APPLICABLE ON
ECO-FRIENDLY SILENT
INVERTER DC PUMP



2-IN-1 DIVERTER



**SPLASH PROOF CASE
COVER WITH IEC
INSULATED PROTECTION**



**BUILT-IN AUTO
WATER FLOW
SWITCH**



**EXTRA SAFETY
DPDT
PROTECTION
SYSTEM**



**COMPACT
WATER FILTER &
STOP VALVE**



**UL-APPROVED HIGH
QUALITY HEATING
ELEMENT TECHNOLOGY
FROM UK**

FLUSSO SERIES



SILENT INVERTER DC PUMP



Power Rating	3.8kW 240V 50Hz
Min. Water Pressure	0.2 Bar
Min. Water Flow Rate	2ℓ / min
Inlet/Outlet Water Connector	ø15mm (1/2" BSP)
Temperature Control	Stepless Electronic
Pump Type	Inverter DC Silent Pump
Noise Level	<45db
Product Dimension (WxDxHmm)	227x75x375

With Rain Shower Set



RWH-FS391D-BRCB

RCP WM **RM 829** / EM **RM 873**

With Black Accessories



RWH-FS391D-BCB

RCP WM **RM 619** / EM **RM 652**

With White Accessories



RWH-FS391D-WMW

RCP WM **RM 599** / EM **RM 631**

With Multi-Angle Accessories



RWH-FS391D-MAW

RCP WM **RM 541** / EM **RM 569**

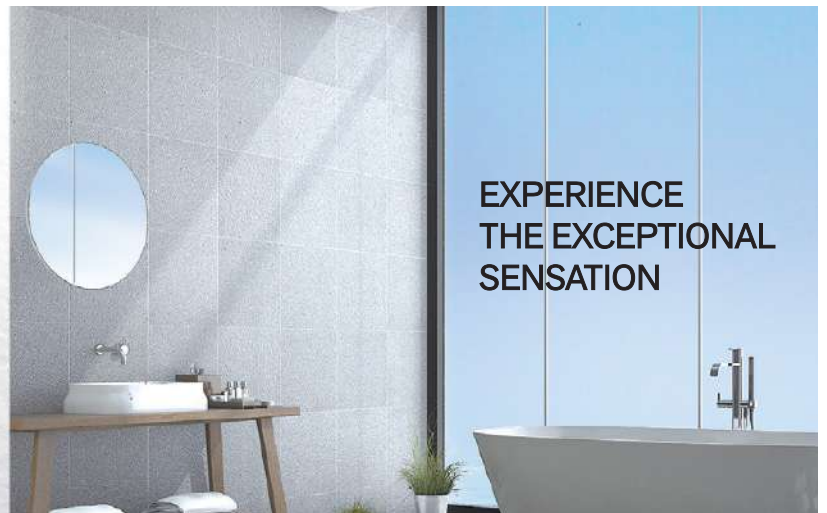



NON PUMP



Power Rating	3.8kW 240V 50Hz
Min. Water Pressure	0.2 Bar
Min. Water Flow Rate	2ℓ / min
Inlet/Outlet Water Connector	ø15mm (1/2" BSP)
Temperature Control	Stepless Electronic
Product Dimension (WxDxHmm)	227x75x375

With Rain Shower Set

CARBON BLACK RWH-FS390N-BRCB

RCP WM **RM 579** / EM **RM 609**



With Black Accessories

CARBON BLACK RWH-FS390N-BCB

RCP WM **RM 399** / EM **RM 420**

With Multi-Angle Accessories

MODERN WHITE RWH-FS390N-MAW

RCP WM **RM 235** / EM **RM 247**



**EXCELLENT QUALITY
WITH IRRESISTIBLE
COMFORTNESS**



CUBO SERIES



CUBO SERIES

DELIGHTFUL
COMPACT DESIGN
WITH MIGHTY POWER

**SAND
BLACK** WITH RAIN SHOWER SET
RWH-C500N-BSB



**EXTRA SAFETY
DPDT
PROTECTION
SYSTEM**



**3+2
SPRAY PATTERNS
HAND SHOWER**



**SPLASH PROOF CASE
COVER WITH IEC
INSULATED PROTECTION**



**BUILT-IN AUTO
WATER FLOW
SWITCH**



**2-IN-1
COMPACT
WATER FILTER &
STOP VALVE**



**360°
ANTI-BREAK
ROTATION**



**UL-APPROVED HIGH
QUALITY HEATING
ELEMENT TECHNOLOGY
FROM UK**

CUBO SERIES



NON PUMP



Power Rating	3.8kW 240V 50Hz
Min. Water Pressure	0.2 Bar
Min. Water Flow Rate	2ℓ / min
Inlet/Outlet Water Connector	ø15mm (1/2" BSP)
Temperature Control	Stepless Electronic
Product Dimension (WxDxHmm)	236x87x259

With Black Accessories

SAND BLACK	RWH-C500N-BSB
RCP	WM RM 245 / EM RM 258

With White Accessories

SAND WHITE	RWH-C500N-WSW
RCP	WM RM 235 / EM RM 247

With Multi-Angle Accessories

SAND BLACK	RWH-C500N-MASB
RCP	WM RM 229 / EM RM 241
SAND WHITE	RWH-C500N-MASW
RCP	WM RM 219 / EM RM 231

3+2*
SPRAY PATTERNS
HAND SHOWER

* Additional two combination spray patterns (1+3) and (2+3)

1 MASSAGE

2 MIDDLE

3 WIDE

+

1+3

2+3

**COMPACT &
QUALITY
INSTANT WATER
HEATER**

PRODUCT DIMENSIONS

With these actual dimensions, you can choose your preferred design from our wide variety of products and do a better installation plans.

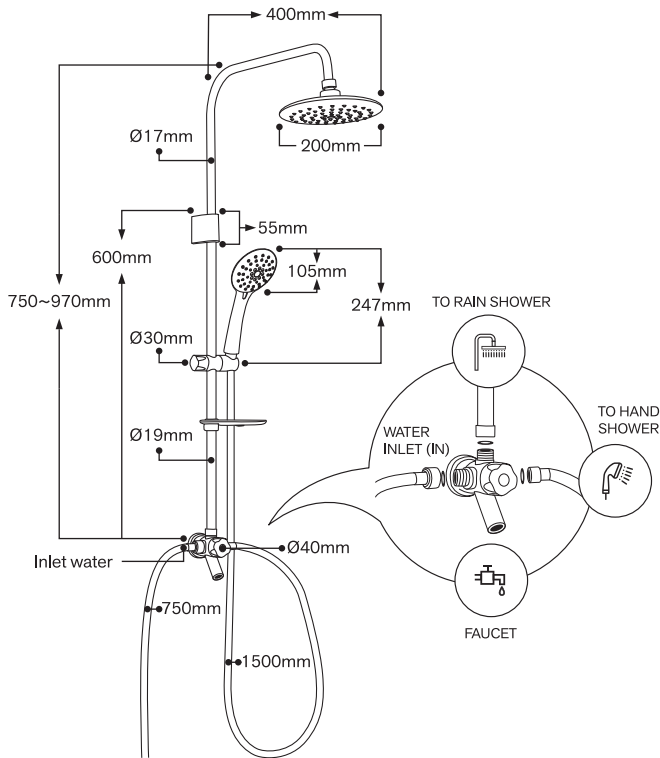

3-IN-1 RAIN SHOWER SET ACCESSORIES

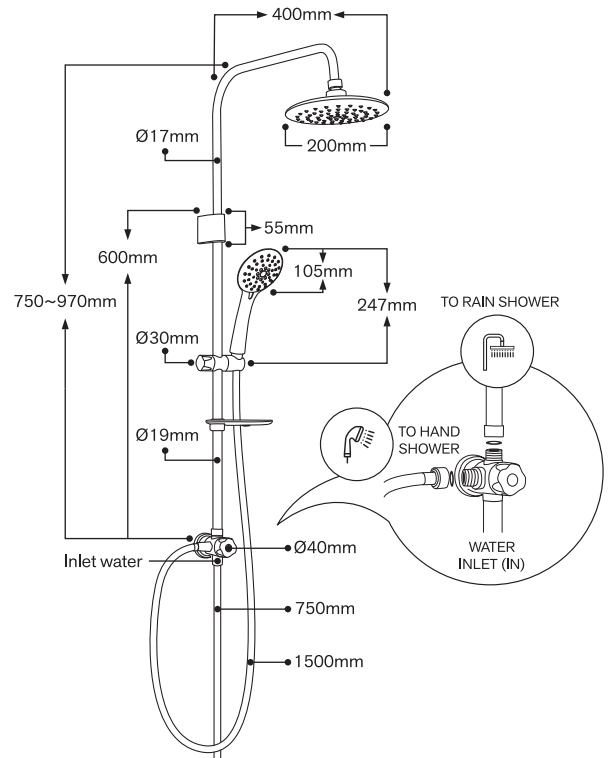

2-IN-1 RAIN SHOWER SET ACCESSORIES

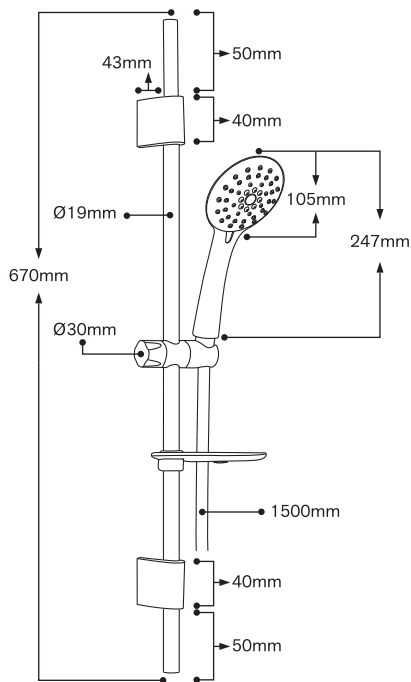

CHROMED ACCESSORIES

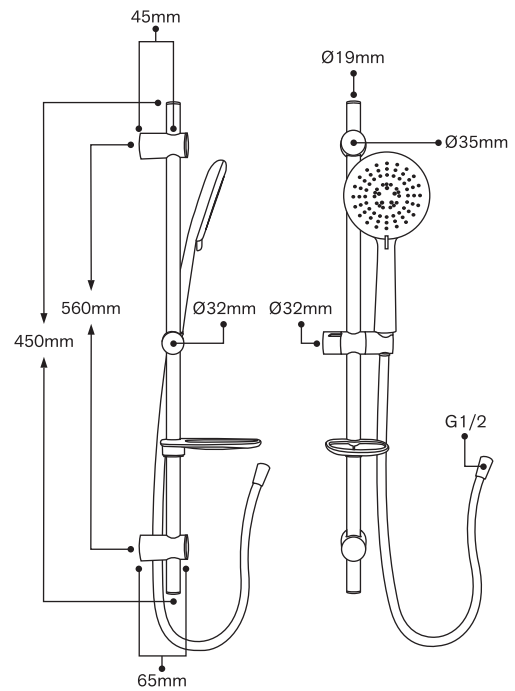

BLACK / WHITE ACCESSORIES

- IMPORTANT:**
- ① Dimensional specifications are provided for planning purposes only.
 - ② Do not use modified parts other than original supplied parts.
 - ③ If need shorter/ longer hose, please to contact qualified installers or authorized Rubine servicer dealers for assistance.

INSTANT WATER HEATER MAINTENANCE TIPS



FILTER CLEANING

For smooth flow and purified water, wash the Water Filter Valve (a) and Hose Filter (b) thoroughly every month or when necessary.



CHECK ELCB/RCCB REGULARLY

Turn on the electricity and water supply to the heater. Pressing in the "Test" button. Both the "Power" & "Heater" indicator light must go off. Press the "Reset" button to resume power. Consult professional for repair if there is any malfunction of ELCB/RCCB.



SWITCH OFF WATER HEATER WHEN NOT IN USE

Switch off water heater after every shower. This will minimise any electrical damage and also save electricity bill.



EXTERNAL WATER FILTER FOR YOUR HOUSE WATER SYSTEM

You are encouraged to install external water filter to maintain purity and optimum stability of water pressure for your showering experiences.

⚠ SAFETY PRECAUTION - DO AND DON'T

Do and don't as a simple guidance to secure you and your beloved family's safety with quality and longer life span of water heater uses.



Flexible 3 Core 2.5mm²
(110/76 20Amp Cable)



2.5mm² PVC Single Core
Insulated Cable with
100% Pure Copper



Children and elderly or disable
person should be supervised



Always ensure the right water
temperature before showering

✓ CORRECT WIRING QUALITY WITHOUT LOOPING

Change wiring with quality specification and do not make looping and share with other appliances while installing water heater.

✓ CHILDREN SHOULD BE SUPERVISED WHILE USE

Ensure that children do not play with the appliances and make sure not to leave children, elderly or disable person alone in shower.

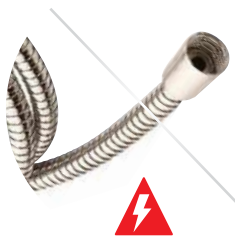

✗ Do not install with
unqualified products



✓ Install with our genuine quality
nonconductive products



✗ Do not leave
hand shower idle in the pail

✗ METAL / CHROMED FLEXIBLE HOSE AND CONDUCTIVE VALVE SHALL NOT BE USED

Assure your safety by using our genuine quality nonconductive flexible hose. Do not replace or install with unqualified products.

✗ DO NOT LEAVE HAND SHOWER IDLE IN THE PAIL

Leaving hand shower in pail will minimize the water flow, causing abnormal overheating and thermostat may cut off.

⚠ IMPORTANT INSTALLATION GUIDELINES

Here are some simple guides of installation and safety precaution.
Always refer to user manual thoroughly and understand the content before use.

1. MOUNTING POSITION

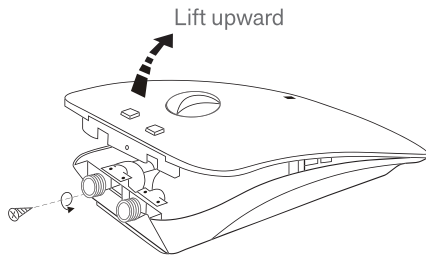

Diagram 1

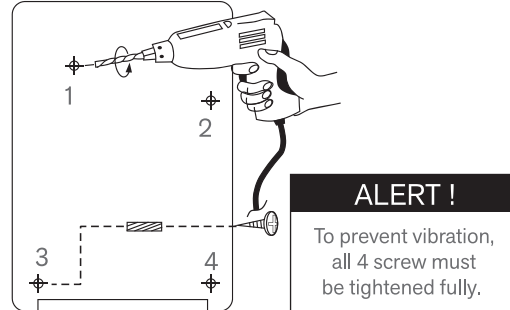
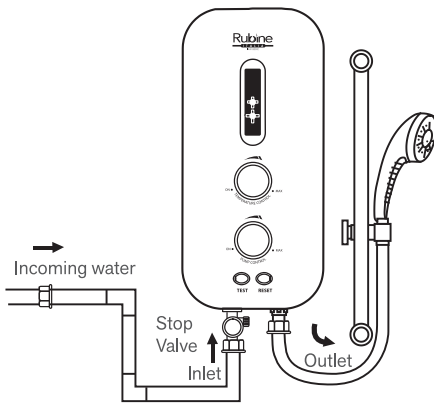

Diagram 2

- Remove screw at the bottom of the heater.
- Lift the plastic cover upward (Refer Diagram 1).
- Mark mounting position on the wall for all 4 screws.
- Drill the holes with 5.0mm diameter drill bit (Refer Diagram 2).
- Install the unit to the wall with plug.
- It is recommended that the unit should be mounted above 1.5m or 5-feet above the floor to bottom of heater.

2. INSTALLATION OF HEATER INLET AND OUTLET



✓ CORRECT INSTALLATION

Connect the stop valve to INLET, connect the piping from stop valve to incoming water supply and connect flexible hose to heater OUTLET

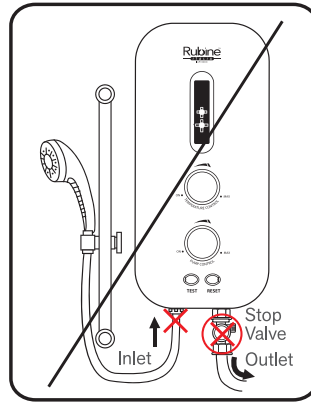

✗ FALSE INSTALLATION

Do not install with inlet-outlet reverse or stop valve reverse.

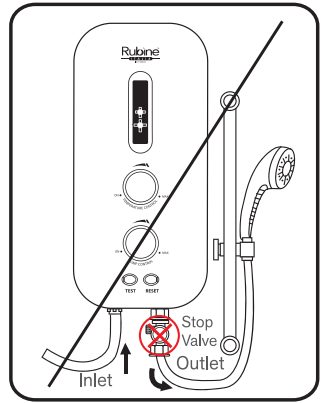

3. ELECTRICAL CONNECTION

- Insert electrical cable through the rubber grommet.
- Connect the cable to the terminal block and fully tighten as below :

IMPORTANT NOTE !

- Switch off the main supply before electrical work.
- Ensure all wiring connection is completely tighten, to prevent current sparking and burnt.

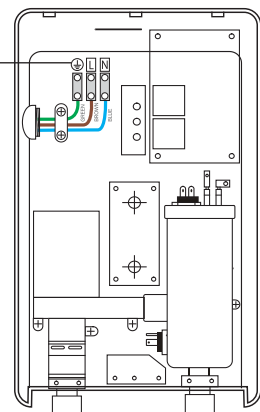
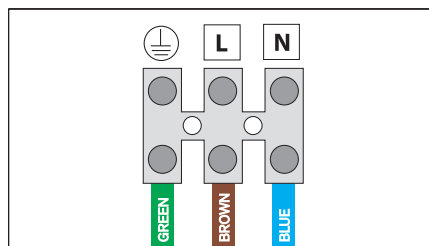

OUR WARRANTY



10 YEARS OF WARRANTY
 APPLICABLE ON
ANTI-TANK LEAKAGE ONLY.



7 YEARS OF WARRANTY
 APPLICABLE ON
HEATING ELEMENT ONLY.



5 YEARS OF WARRANTY
 APPLICABLE ON
SILENT INVERTER DC PUMP ONLY.



1.5 YEARS OF WARRANTY
 APPLICABLE ON **LOW NOISE**
INVERTER AC PUMP ONLY.



1 YEAR OF WARRANTY
 APPLICABLE ON
INTERNAL PARTS ONLY.



6 MONTHS OF WARRANTY EXTENSION
 REGISTER ONLINE NOW AND GET
6 MONTHS WARRANTY EXTENSION !

ONLINE REGISTRATION

1. Log on to www.rubine.com.my
2. Click on 'Support', followed by 'Products Warranty Registration' to proceed. You're required to sign up as a member.
3. Please fill up the necessary information, tick on the checkbox and click 'Next'.
4. You'll receive notification of warranty registration confirmation via email.
5. Your warranty will be automatically extended for another 6 months upon online registration. Please keep your online warranty certificate for future services.

* Please find out from our authorized dealers for extended warranty!



CUSTOMER CARE & WAYS TO REACH TO US



AFTER-SALES SERVICE

Contact: 03 – 6279 8899
 Email: ftcrm@fiamma.com.my



OPERATION HOURS

09.00am – 05.00pm
 Monday–Friday, except public holiday

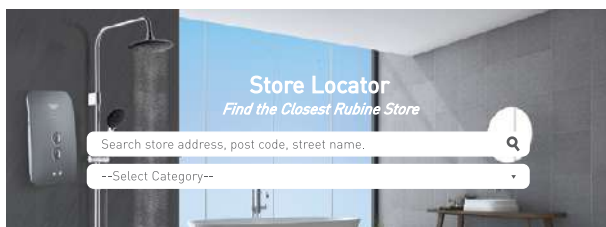

WAYS TO REACH TO US

Whenever you think of instant water heater, please pay a visit to your nearest Rubine store or find us online to get instant inquiry: rubine.com.my

*Product images are for illustration purposes only.



REDEFINE THE WAY OF LIFE

V1.2024



rubine.com.my



FIAMMA TRADING SDN BHD 330476-P (A member of Fiamma Holdings Berhad)

2-1, Wisma Fiamma, No.20, Jalan 7A/62A, Bandar Manjalara, 52200 Kuala Lumpur.



[rubinemalaysia](https://www.facebook.com/rubinemalaysia)



03-6279 8899