

PRODUCT INFORMATION

Eightfold Sdn Bhd (775128-W)
69-1, Jalan SS19/6, 47500 Subang Jaya,
Selangor Darul Ehsan, Malaysia
Tel: 03-5612 8169 Fax: 03-2726 8806
www.eightfold.com.my



WIRED ESB901 DISABLE TOILET CALL SYSTEM

ESB901 includes everything required for a BS8300 clause (UK) compliant emergency assistance alarm (except cables & fixings). Attractively designed and simple to use, it allows a distressed person to raise an alarm in the event of an emergency.

To operate, the user simply pulls the cord of a ceiling pull unit to activate a light and sounder outside the calling room. Ideal for use in all types of disabled persons/accessible toilet applications, the ESB901 can also be used as a single zone emergency assistance alarm in changing rooms, solariums, accessible bedrooms, interview rooms, reception areas, etc.

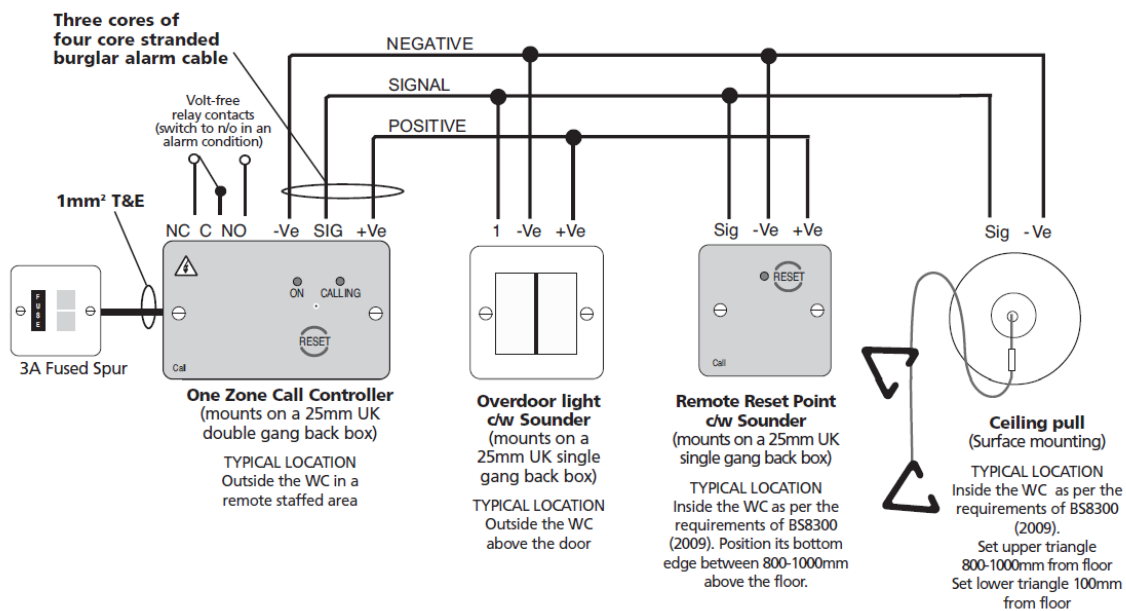

Features:

- Attractive compact design blends perfectly into any sort of decor
- Double gang call controller features a volt-free relay output, a rotary volume control,
- Braille text and on-board rechargeable battery backup facility
- Remote reset point c/w sounder provides audible and visual indication of an alarm call
- inside the WC to reassure users help is on the way
- Simple to install 12V system - four core stranded security cable is ideal for most installations
- Ceiling pull features two open sided triangular bangles for ease of use by the infirm
- Disabled WC sticker included in all kits
- All wall-mounting plastic accessories fit 25mm backboxes. Ceiling pull is surface mountable
- Rechargeable back-up battery provides up to 24 hrs stand-by and 15 mins alarm running time

Any enquiry please contact the following:

Jim Tan 012-8098169
Iza 018-212 1373
Email eightfoldsb@gmail.com

PRODUCT INFORMATION

Eightfold Sdn Bhd (775128-W)
69-1, Jalan SS19/6, 47500 Subang Jaya,
Selangor Darul Ehsan, Malaysia
Tel: 03-5612 8169 Fax: 03-2726 8806
www.eightfold.com.my



EU Declaration of Conformity *NC951 Accessible Toilet Alarm Kit*

Product Model Designation(s) & Description(s)

- NC951 Accessible Disabled Persons Toilet Alarm Kit

Kit contents:

NC943B	Single Zone Call Controller c/w Sounder
NC809DBBT	Accessible Toilet Reset Point c/w Sounder
NC806CS	Overdoor Light c/w Sounder
NC807C	Ceiling Pull
NC949	Accessible WC Sticker (<i>N/A to EMC/LVD standards</i>)

Manufactured by C-TEC at:

Computationics Ltd (Trading as C-TEC) Challenge Way, Martland Park
Wigan, WN5 0LD, United Kingdom

are in conformity with the provisions of the following EU Directive(s):

- 2014/30/EU: Electromagnetic Compatibility Directive (EMC)
- 2014/35/EU: Low Voltage Directive (LVD)
- 2011/65/EU: Restriction of Use of certain Hazardous Substances Directive (RoHS)

The products to which this declaration relates have been tested to and are in conformity with the following standards:

- EN 50130-4:2011+A1:2014 Alarm Systems – Part 4: Electromagnetic compatibility - Product family standard: Immunity requirements for components of fire, intruder and social alarm systems.
- EN 61000-6-3: 2007+A1:2011 Electromagnetic compatibility (EMC) – Part 6-3: Generic standards - Emission standard for residential, commercial and light-industrial environments.
- EN 60950-1:2006/A2:2013 Information technology equipment — Safety — Part 1: General requirements
- EN50581: 2012 Technical documentation for the assessment of electrical and electronic products with respect to the restriction of hazardous substances

Empowered Signatory of Company

I, the undersigned, hereby declare on behalf of Computationics Limited that the products listed above comply with the requirements of the standards listed above which gives presumption of conformity with the essential requirements of the directives listed above.

Name: Stephen A. Stringfellow

Position: Research & Development Manager

Signature:

Date: 16.8.16