



KTV 3

KTV 4

KTV ATRIUM



EN 16005
DIN 18650

03	Editorial	16	Dependency table
	Data and features	18	Turnstile versions
04	KTV Revolving doors	19	Wing locks
05	KTV FLEX Direct	20	Options
06	Function modules	22	Ceiling structure / façade connection
08	KTV details	24	Floor ring
10	KTV standard	26	Wiring diagrams
12	KTV with glass ceiling	28	Safety equipment
14	KTV ATRIUM	30	Access security

The main entrance gives a clear statement of your company's image. It is extremely important that it conveys a positive first impression, as well as allows a smooth flow of traffic.

The KTV series of dormakaba revolving doors combines these two characteristics perfectly. They significantly reduce background noise, dust and dirt. Employees in the vicinity of these entrances benefit from reduced draft.

Data and features

Dimensions	
Internal diameter	2000–3800 mm, all dimensions possible in-between
External diameter	Internal diameter + max. 96 mm without night shield
Clear passage height	2100–4000 mm*
Canopy height	17.5–700 mm*
Total height	Clear passage height + canopy height

* See table pages 16/17

Traffic capacity				
Internal diameter (D) in mm	Theoretical capacity ¹⁾ Persons/hour ↔		Maximum capacity ²⁾ Persons/minute →	
	KTV 3	KTV 4	KTV 3	KTV 4
2000	2520	3120	21	26
2600	3960	2640	33	22
3000	3360	4560	28	38
3400	4440	3960	37	33
3800	5400	5400	45	45

¹⁾ The theoretical capacity value indicates how many people can pass through the revolving door in both directions (↔) per hour, assuming that the traffic flow is uniform and the internal segments are constantly occupied.

²⁾ The maximum capacity value indicates how many people can pass through the revolving door in one direction (→) per minute when, for a certain limited period, there is a constant stream of traffic, for example in the morning and evening.

KTV revolving doors

Exceptionally versatile



The KTV revolving doors from dormakaba combine maximum comfort of use, safety and freedom of design. A variety of modular components and operation modes makes it possible to flexibly adapt to local conditions and on-site needs. The KTV revolving doors are characterized by high performance in cases of heavy public traffic, options for access control (KTV SECURE) and elegant all-glass designs with invisible drive and control technology (KTV ATRIUM).

Any inside diameter of door can be supplied from 2000–3800 mm. Depending on the diameter, clear passage heights of up to 4000 mm can be achieved.

KTV series revolving doors can be equipped with:

- 3- or 4-wings
- Glazed drum walls or with metal paneling
- Additional curved sliding doors in front of the entrance to act as night shields
- Manual operation with or without speed limiter (KTV M)
- Low-energy positioning automatic drive system (KTV P)
- Low-energy servomatic drive system (KTV S)
- Full-energy automatic operation drive system (KTV A)
- Accessories that ensure compliance with the requirements of DIN 18650 and EN 16005

and a variety of other accessories and options.

Benefits for the installer

- Flexible system to suit your requirements
- Easy installation and rapid commissioning
- State-of-the-art design and compliance with regulations

Benefits for the user

- Enhanced working conditions
- Optimization of the building energy balance
- Efficient noise protection
- Tailored integrated application combining industrial engineering precision and assured quality

Benefits for the architect/specifier

- Extensive design flexibility in terms of planning and technical requirements
- Visually, technically and economically the ideal application

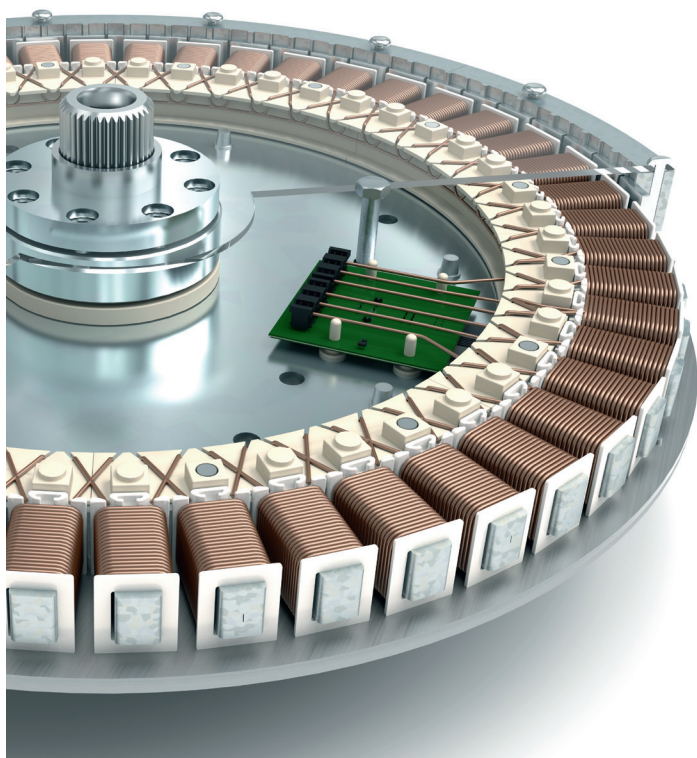

KT FLEX Direct – The new drive

The new electromagnetic direct-drive principle minimizes tolerances and wear, and the door wings can be moved and positioned very accurately. The gearless power transmission is based on magnetic technology – proven tens of thousands of times by dormakaba door drives.

For the first time, this drive technology makes it possible to combine the elegance of a slim floor construction having an installation height of only 100 mm with a drive system concealed in the ceiling.*

The drive system is available in the following designs:

- With a speed limiter for manual doors (standard)
- With an automated positioning system (low-energy drive)
- With Servomatic (low-energy drive)
- With Automatic (full-energy drive)

Advantages

Installation in the ceiling

protects the drive from environmental influences such as rain water or dirt, but also from aggressive cleaning agents

Low-wear and low-noise direct drive

provides soft movement and protects the equipment's mechanical components

Increased positioning precision

improves climatic separation of indoor and outdoor area, reduces drafts and supports a consistent indoor climate

Fast installation and easy commissioning

ensure high availability and reduce acquisition costs

Individually adjustable speed limitation

increases the safety of the equipment and protects against vandalism and excessive acceleration of the system (available with KTV M/P/S)

Various drive options

allow the selection of a customized solution for almost any application

* For technical reasons, the drive system is not available in KTV SECURE, KTV ATRIUM and KTV type doors with glass ceiling. Doors with the "Shock-Stop" anti-vandalism brake or underfloor drive options cannot be equipped with this new drive system. In these cases, the conventional drive systems are used.

Function modules



Article for upgrading with KTV direct drive

Designation	Quantity KTV 3	Quantity KTV 4	Article number
Drive system (KTV direct drive)	1	1	60450001
KTV direct drive function module "P"	1	1	60450010
KTV direct drive function module "S"	1	1	60450020
KTV direct drive function module "A"	1	1	60450030
KTV program switch	1	1	9501460010900
Motion sensor Easy Motion Stereo	4	4	9501460070900
Passive safety bumper (leading mullion)	2	2	9500560017600 9500530041500 9500530416000
Active safety bumper (wing, bottom)	3	4	9500560017200 9500530082300
Active safety bumper (wing, side)	3	4	9500560017100 9500530082400
Canopy safety sensor	2	2	9501460057920
Safety sensors (wing, top), required when door diameter > 3000 mm	3	4	9501460056500 9501460056600 9501460057000 9501460056700
Emergency stop button internal and external	1 (2)	1 (2)	9501460050210
Disabled access pushbutton	2	2	9501460007600
Mullion extension package (required for integrating program switch, safety bumper and disabled access pushbutton)	1	1	9501900244800 9500530041700 9501900244900 9500530046900 9500530041900 9500530053700 9500590045800

Modular design of the direct drive system

The basic system consists of a motor, controller and power supply unit, which is used in the same way for all operator types. This makes it easy to make aftermarket changes and expansions to the functionality of the system, depending on the customer's requirements*.

Selection of operator types via function modules

Different operator types can be implemented according to the requirements by using the dormakaba function module (only for direct drive). The installation is easily performed. The corresponding function module is plugged into the slot of the controller and the functions are automatically available as long as the respective function module remains in the controller.

Required safety accessories in accordance with DIN 18650 or EN 16005 or other optional accessories are available.

M – Manual door

The door is to be operated manually. A speed limiter prevents the door from rotating too quickly beyond an adjustable speed.

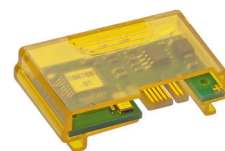

"P" – Automated positioning system (low-energy)

Electromagnetic direct drive with 2 operation modes that can be selected using a program switch.

Operation mode 1: The door is to be operated manually and automatically rotates to its starting position after each use.

Operation mode 2: The door permanently rotates at a reduced speed and acceleration to walking speed is achieved manually.



"S" – Servomatic (low-energy)

Electromagnetic direct drive with 2 operation modes that can be selected using a program switch.

Operation mode 1: Motion sensors start the rotary movement of the door wings at a low speed. Acceleration to walking speed is achieved manually. The door rotates back to the starting position after each use.

Operation mode 2: The door permanently rotates at a reduced speed and acceleration to walking speed is achieved manually.



"A" – Automatic (full-energy)





Electromagnetic direct drive with operation modes that can be adjusted using a program switch.

Operation mode 1: Motion sensors start the rotation of the door wings at a walking pace. The door rotates back to the starting position after each use.

Operation mode 2: The door permanently rotates at a reduced speed, and acceleration to walking speed is automated by means of a movement sensor.

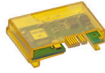
* The modification requires a detailed analysis of the preselected system by a dormakaba specialist in order to be able to make a detailed assessment of the complexity of the modification.

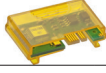
Upgrade packages for modifying the KTV operation modes (with direct drive system in accordance with DIN 18650/EN 16005)

from to	"M" – Manual door	"M" – Manual door with speed limiter	 "P" – Automated positioning system	 "S" – Servomatic
Manual with speed limiter	- Drive system			
"P" – Automated positioning system* 	- Mullion extension package - Drive system + function module P - Program switch - Passive safety bumper (leading mullion) - Emergency stop button (internal)	- Mullion extension package - Function module P - Program switch - Passive safety bumper (leading mullion) - Emergency stop button (internal)		
"S" – Servomatic* 	- Mullion extension package - Drive system + function module S - Program switch - Motion sensors - Passive safety bumper (leading mullion) - Emergency stop button (internal)	- Mullion extension package - Function module S - Program switch - Motion sensors - Passive safety bumper (leading mullion) - Emergency stop button (internal)	- Function module S - Motion sensors	
"A" – Automatic* 	- Mullion extension package - Drive system + function module A - Program switch - Motion sensors - Passive safety bumper (leading mullion) - Active safety bumper (wing, bottom) - Active safety bumper (wing, side) - Canopy safety sensor - Safety sensors (wing, top), required when door diameter > 3000 mm - Emergency stop button internal & external (EN 16005 only internal) - Option: Disabled access pushbutton	- Mullion extension package - Function module A - Program switch - Motion sensors - Passive safety bumper (leading mullion) - Active safety bumper (wing, bottom) - Active safety bumper (wing, side) - Canopy safety sensor - Canopy safety sensor - Safety sensors (wing, top), required when door diameter > 3000 mm - Emergency stop button internal & external (EN 16005 only internal) - Option: Disabled access pushbutton	- Function module A - Motion sensors - Active safety bumper (wing, bottom) - Active safety bumper (wing, side) - Canopy safety sensor - Safety sensors (wing, top), required when door diameter > 3000 mm - External emergency stop button (EN 16005 not required) - Option: Disabled access pushbutton	- Function module A - Active safety bumper (wing, bottom) - Active safety bumper (wing, side) - Canopy safety sensor - Safety sensors (wing, top), required when door diameter > 3000 mm - External emergency stop button (EN 16005 not required) - Option: Disabled access pushbutton

* Additional accessories may be required for special door types such as fine-frame doors or doors with additional equipment such as a night shield or locking device systems.

KTV equipment features / normative specifications

Door type	KTV 3 / 4				
	"M" – Manual door	"P" – Automated positioning system	"S" – Servomatic	"A" – Automatic	
Operator type					
Safety standard	-	EN 16005/DIN 18650	EN 16005/DIN 18650	EN 16005	DIN 18650
Handles	●	●	●		
Motion sensors	-	-	●	●	●
Canopy safety sensor	-	-	-	●	●
Safety sensors (wing, top)	-	-	-	● Ø > 3 m	● Ø > 3 m
Passive safety bumper (leading mullion)	-	passive	passive	passive	passive
Active safety bumper (wing, bottom)	-	-	-	active	active
Active safety bumper (wing, side)	-	-	-	active	active
Internal emergency stop button	-	●	●	●	●
External emergency stop button	-	○	○	○	●
Disabled access pushbuttons internal & external	-	-	-	○	○
Adjustable speed limiter	○	● (KTV direct drive) ○ (conventional operator)	● (KTV direct drive) ○ (conventional operator)	-	-
Program switch		●	●	●	●

● = Standard equipment ○ = optional equipment - = not required











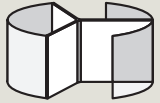
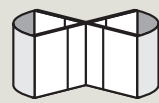
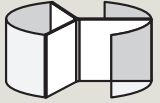













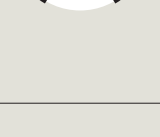
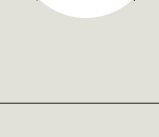

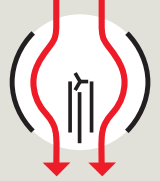
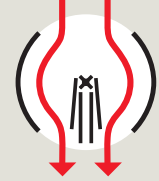

KTV details

Detail	Direct drive	KTV with conventional operator	KTV with glass ceiling	KTV ATRIUM All-glass unit
			in the P/S versions, with conventional underfloor drive only	
Drum wall, framed glass	○	○	○	–
Drum wall, metal paneling	○	○	○	–
All-glass drum wall without frame	–	–	–	○
Suitable for emergency exits and escape routes*	○	○	3200–3800 mm	–
Wings with push handles (KTV M/P/S)	○	○	○	○
Manual night shield, internal	○	○	–	–
Manual night shield, external	○	○	○	○
Electrical night shield, internal	○ (KTV 4)	○ (KTV 4)	–	–
Mechanical locking device for wings	○	○	○	○
Mechanical locking device for night shield	○	○	○	○
Electrical wing locking device	○	○	–	–
Electrical locking device, electrical night shield	○	○	–	–
Positioning automatic (P), canopy-integrated direct drive system	○	○	–	–
Positioning automatic (P), underfloor operator	–	○	○	○
Servomatic (S), canopy-integrated direct drive system	○	○	–	–
Servomatic (S), underfloor operator	–	○	○	○
Automatic (A), canopy-integrated direct drive system	○	○	–	–
Automatic (A), underfloor operator	–	○	○	–
Framed rigid turnstile	○	○	○	–
Framed breakout turnstile "bookfold" (suitable for application in emergency exits and escape routes)	○	○	3200–3800 mm	–
Framed breakout turnstile, 1-wing, hinged (transport opening)	○	○	○	–
Fine-framed rigid wings	○	○	○	○
Midrails for wings	○	○	○	–
Midrails for drum walls	○	○	○	–
Floor ring	○	○	○	○
Floor mat (ribbed carpet insert/rubber insert)	○	○	○	○
Ceiling-integrated downlights	○	○	–	–
Ceiling prepared for rainproofing (by others)	○	○	–	–
Rainproofed sheet metal ceiling	○	○	○	–
Anti-vandalism brake ("Shock-Stop")	–	○	○	–
Speed limiter	○	○	○	○
EN 16005/DIN 18650 compliant safety equipment	○	○	○	○

○ = available as an option – = not available

* depending on local regulations

KTV models

Models	KTV 3	KTV 4	KTV 3 ATRIUM	KTV 4 ATRIUM
				
Operator types				
M – Manual Purely manual door operation. A speed limiter is available as an option (standard with direct drive)				
P – Positioning automatic Low-Energy drive system Mode 1: - manual operation - automatic positioning after passage Mode 2: - permanent rotation (slow) - manual acceleration (walking speed)	Operation Mode 1 			
S – Servomatic Low-Energy drive system Mode 1: - automatic start (slow) - manual acceleration (walking speed) - automatic positioning after passage Mode 2: - permanent rotation (slow) - manual acceleration (walking speed)	Operation Mode 2 			
A – Automatic Full-Energy drive system Mode 1: - automatic start (walking speed) - automatic positioning after passage Mode 2: - permanent rotation (slow) - automatic acceleration (walking speed)				
Configurations				
Transport opening Allowing to pass through the door with bulky items or luggage (optional)				
Emergency escape configuration* With breakout fittings (optional)				
Options				
Locking device (optional) See also versions on page 19				
Night shield, internal (optional)				
Night shield, external (optional)				

* depending on local regulations

KTV standard

Dimensions of KTV 3

3-wing design (without night shield)

Internal diameter (D)	2000	2200	2400	2600	2800	3000	3200	3400	3600	3800
External diameter (B)	2096	2296	2496	2696	2896	3096	3296	3496	3696	3896
Clear passage width (LW)	940	1040	1140	1240	1340	1440	1540	1640	1740	1840
Escape route width	895	995	1095	1195	1295	1395	1495	1595	1695	1795

3-wing design (with single-piece external night shield)

Internal diameter (D)	2000	2200	2400	2600	2800	3000	3200	3400	3600	3800
External diameter (B)	2262	2462	2662	2862	3062	3262	3462	3662	3862	4062
Clear passage width (LW)	940	1040	1140	1240	1340	1440	1540	1640	1740	1840
Escape route width	895	995	1095	1195	1295	1395	1495	1595	1695	1795

3-wing design (with single-piece internal night shield)

Internal diameter (D)	2000	2200	2400	2600	2800	3000	3200	3400	3600	3800
External diameter (B)	2216	2416	2616	2816	3016	3216	3416	3616	3816	4016
Clear passage width (LW)	940	1040	1140	1240	1340	1440	1540	1640	1740	1840
Escape route width	895	995	1095	1195	1295	1395	1495	1595	1695	1795

All dimensions in mm.

KTV M/P/S/A

Rigid wings or breakout wings. Drum wall options:

- Curved aluminum special profiles, 70 x 46 mm mullions, base profile section height (at top and bottom): 100 mm, 8.6 mm laminated safety glass or 8 mm toughened safety glass. Laminated safety glass is pendulum body impact resistant according to DIN 52290 Class A1 (German Industrial Standard).
- Curved aluminum special profiles, 70 x 46 mm, base section height (at top and bottom): 100 mm, filled with panels (sheet metal surface with styrofoam core) 18 mm.

KTV 3 M/P/S/A

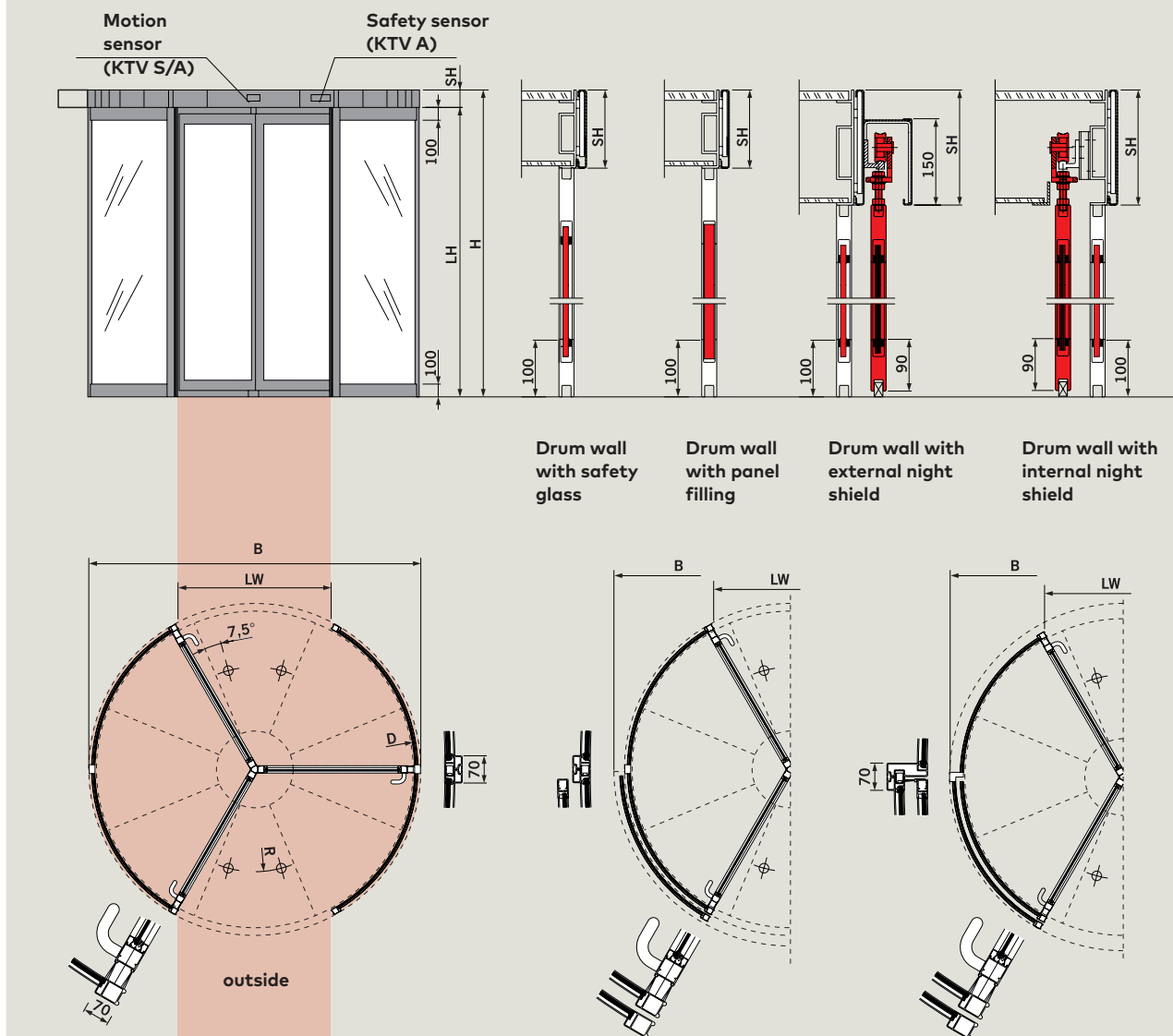

- Also available with internal or external night shield, filled with 8.6 mm laminated safety glass, 8 mm toughened safety glass or 18 mm panel filling as an option. Laminated safety glass is pendulum body impact resistant according to DIN 52290 Class A1 (German Industrial Standard).

Dimensions of KTV 4

4-wing design (without night shield)

Internal diameter (D)	2000	2200	2400	2600	2800	3000	3200	3400	3600	3800
External diameter (B)	2096	2296	2496	2696	2896	3096	3296	3496	3696	3896
Clear passage width (LW)	1364	1505	1647	1788	1930	2071	2213	2354	2496	2637
Escape route width	895	995	1095	1195	1295	1395	1495	1595	1695	1795

4-wing design (with double-leaf external night shield)

Internal diameter (D)	2000	2200	2400	2600	2800	3000	3200	3400	3600	3800
External diameter (B)	2262	2462	2662	2862	3062	3262	3462	3662	3862	4062
Clear passage width (LW)	1364	1505	1647	1788	1930	2071	2213	2354	2496	2637
Escape route width	895	995	1095	1195	1295	1395	1495	1595	1695	1795

4-wing design (with double-leaf internal night shield)

Internal diameter (D)	2000	2200	2400	2600	2800	3000	3200	3400	3600	3800
External diameter (B)	2216	2416	2616	2816	3016	3216	3416	3616	3816	4016
Clear passage width (LW)	1364	1505	1647	1788	1930	2071	2213	2354	2496	2637
Escape route width	895	995	1095	1195	1295	1395	1495	1595	1695	1795

All dimensions in mm.

KTV 4 M/P/S/A

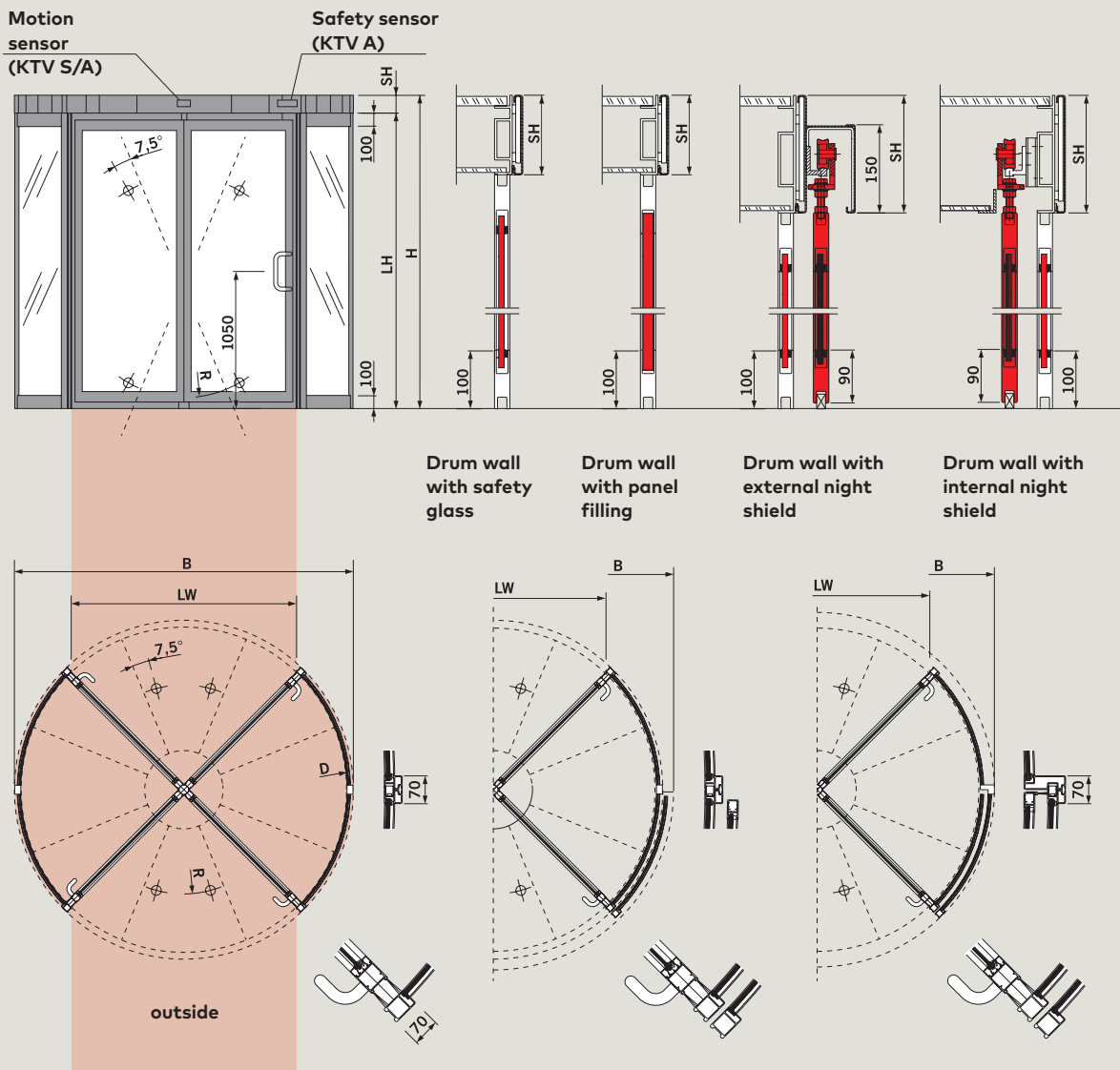

KTV with glass ceiling

Dimensions of KTV 3 with glass ceiling

3-wing design (without night shield)

Internal diameter (D)	2000	2200	2400	2600	2800	3000	3200	3400	3600	3800
External diameter (B)	2092	2292	2492	2692	2892	3092	3292	3492	3692	3892
Clear passage width (LW)	940	1040	1140	1240	1340	1440	1540	1640	1740	1840
Escape route width	895	995	1095	1195	1295	1395	1495	1595	1695	1795

3-wing design (with double-leaf external night shield)

Internal diameter (D)	2000	2200	2400	2600	2800	3000	3200	3400	3600	3800
External diameter (B1) without cover for door suspension	2188	2388	2588	2788	2988	3188	3388	3588	3788	3988
External diameter (B2) with cover for door suspension	2258	2458	2658	2858	3058	3258	3458	3658	3858	4058
Clear passage width (LW)	940	1040	1140	1240	1340	1440	1540	1640	1740	1840
Escape route width	895	995	1095	1195	1295	1395	1495	1595	1695	1795

All dimensions in mm.

KTV M/P/S/A

Rigid wings or breakout wings. Drum wall options:

- Curved aluminum special profiles, 70 x 46 mm mullions, base profile section height (at top and bottom): 100 mm, 8.6 mm laminated safety glass or 8 mm toughened safety glass. Laminated safety glass is pendulum body impact resistant according to DIN 52290 Class A1 (German Industrial Standard).
- Curved aluminum special profiles, 70 x 46 mm, base section height (at top and bottom): 100 mm, filled with panels (sheet metal surface with styrofoam core) 18 mm.

KTV 3 with glass ceiling M/P/S/A

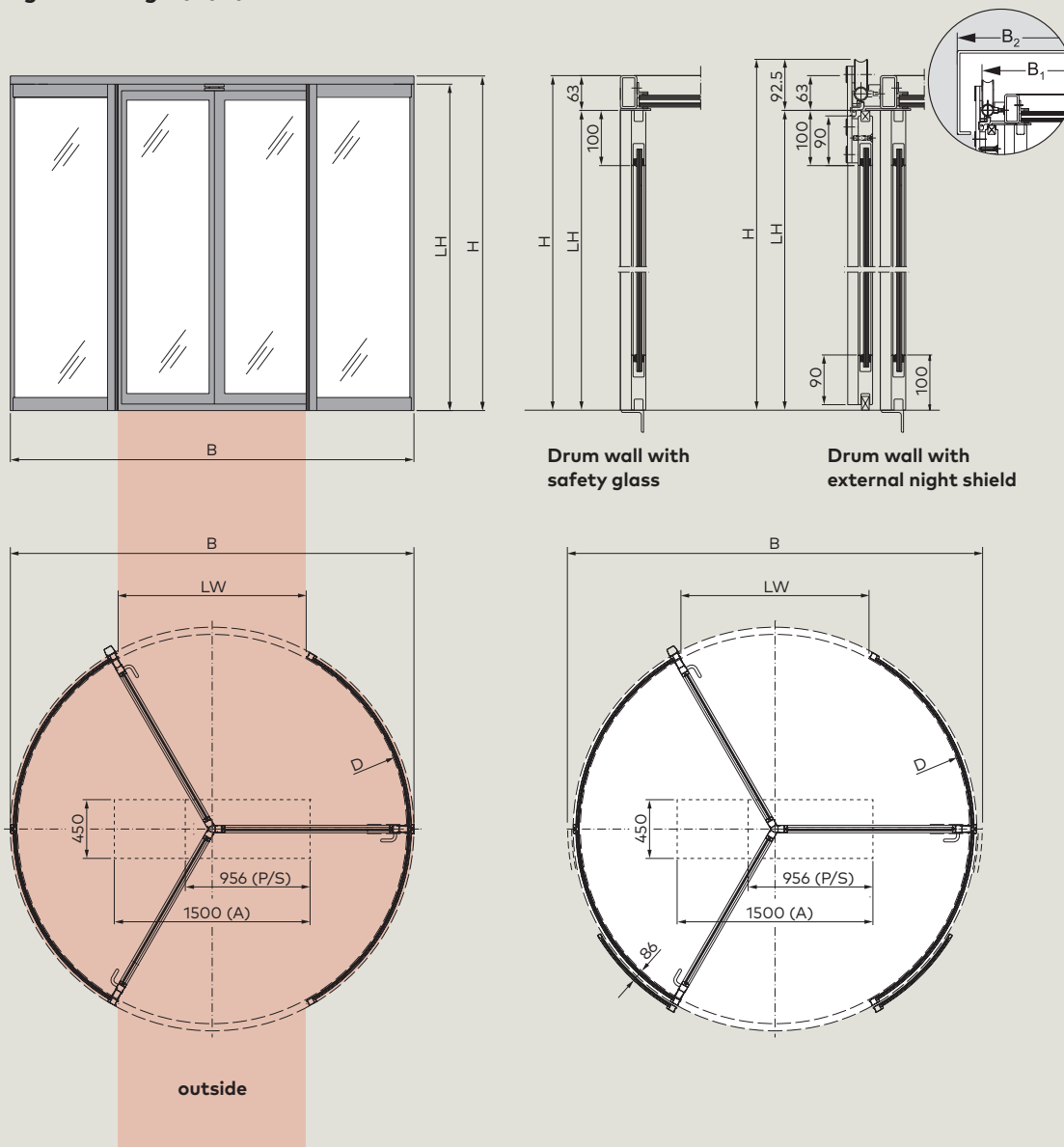

- Also available with internal or external night shield, filled with 8.6 mm laminated safety glass, 8 mm toughened safety glass or 18 mm panel filling as an option. Laminated safety glass is pendulum body impact resistant according to DIN 52290 Class A1 (German Industrial Standard).
- Up to D = 3000 mm also available with glass ceiling and point fittings (breakout wings not available).

Dimensions of KTV 4 with glass ceiling

4-wing design (without night shield)										
Internal diameter (D)	2000	2200	2400	2600	2800	3000	3200	3400	3600	3800
External diameter (B)	2092	2292	2492	2692	2892	3092	3292	3492	3692	3892
Clear passage width (LW)	1364	1505	1647	1788	1930	2071	2213	2354	2496	2637
Escape route width	895	995	1095	1195	1295	1395	1495	1595	1695	1795
4-wing design (with double-leaf night shield)										
Internal diameter (D)	2000	2200	2400	2600	2800	3000	3200	3400	3600	3800
External diameter (B1) without cover for door suspension	2188	2388	2588	2788	2988	3188	3388	3588	3788	3988
External diameter (B2) with cover for door suspension	2258	2458	2658	2858	3058	3258	3458	3658	3858	4058
Clear passage width (LW)	1364	1505	1647	1788	1930	2071	2213	2354	2496	2637
Escape route width	895	995	1095	1195	1295	1395	1495	1595	1695	1795

All dimensions in mm.

KTV 4 with glass ceiling M/P/S/A

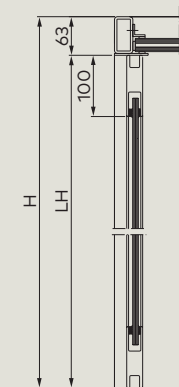
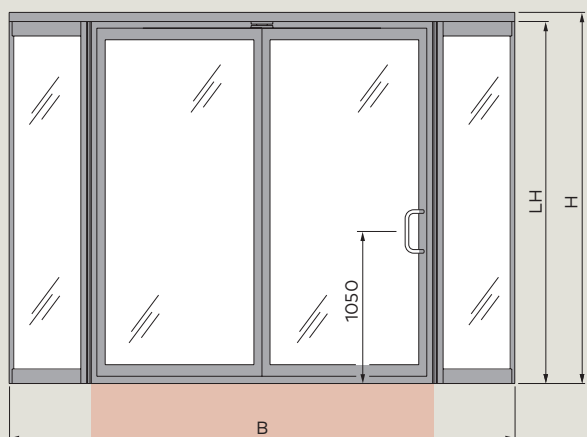

Drum wall with safety glass

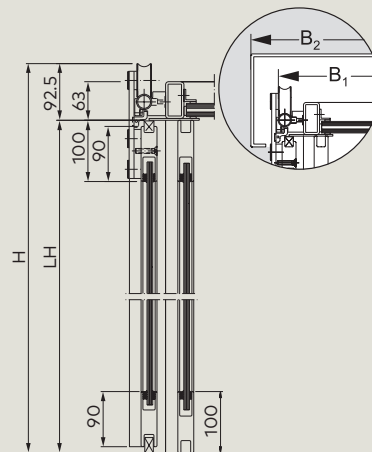

Drum wall with external night shield

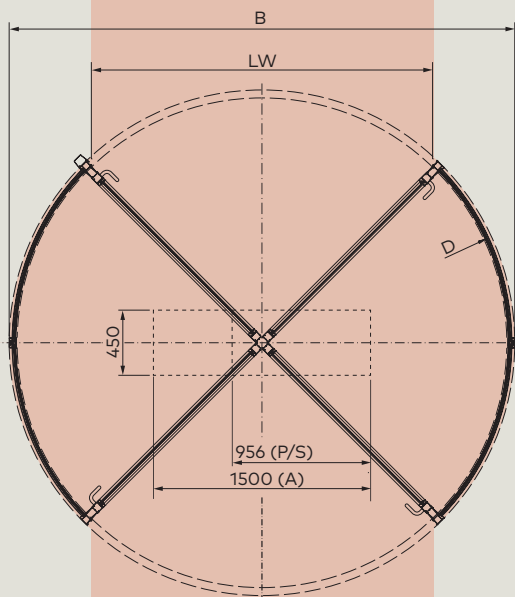

outside

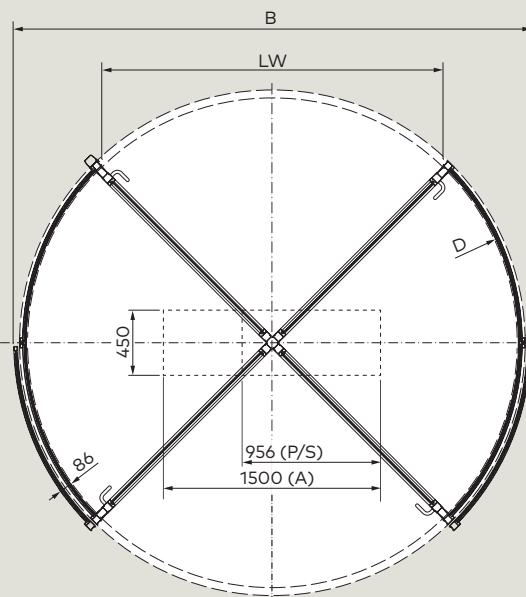

KTV ATRIUM

Dimensions KTV 3 ATRIUM

3-wing design (without night shield)

Internal diameter (D)	2000	2200	2400	2600	2800
External diameter (B)	2048	2248	2448	2648	2848
Clear passage width (LW)	957	1057	1157	1257	1357

3-wing design (with single-leaf external night shield)

Internal diameter (D)	2000	2200	2400	2600	2800
External diameter (B)	2112	2312	2512	2712	2912
Clear passage width (LW)	957	1057	1157	1257	1357

All dimensions in mm.

KTV M/P/S

Rigid wings.

Drum side walls:

- 17.5 mm laminated safety glass, with brushed stainless steel edge trim
- Optional external night shield (10 mm laminated safety glass)

Ceiling:

- 2 x 10 mm laminated safety glass made from tempered safety glass (TVG)
- 2 x 12 mm (outside half of ceiling in case of optional night shield)

Wings:

- 12 mm laminated safety glass

KTV 3 ATRIUM M/P/S

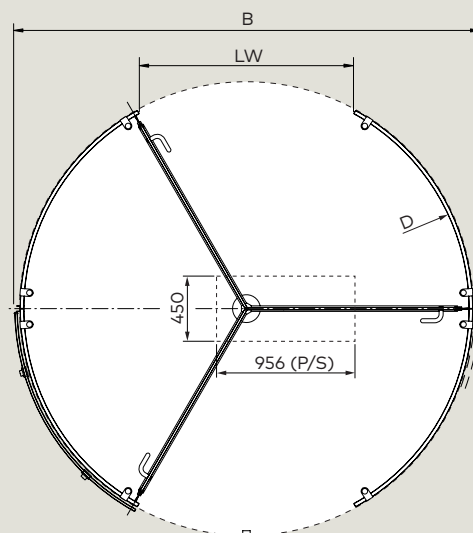
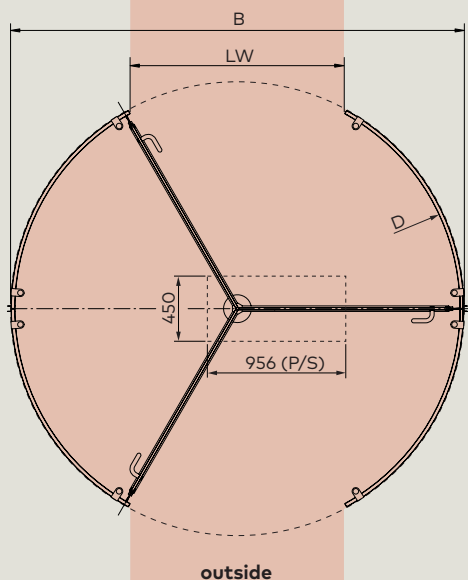
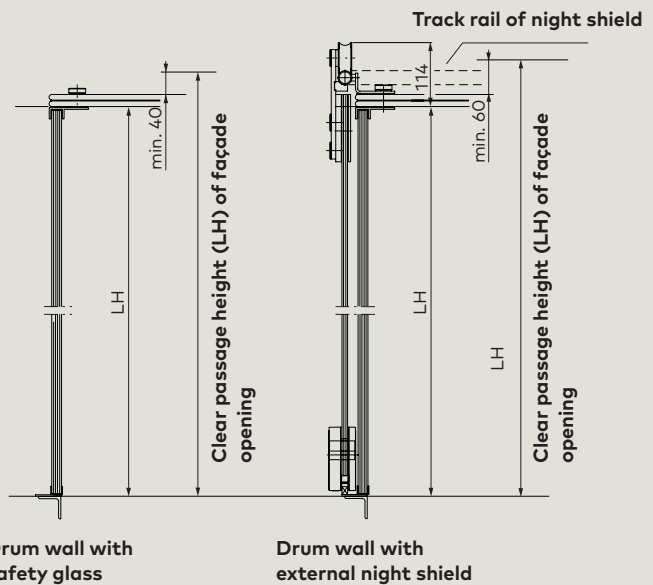
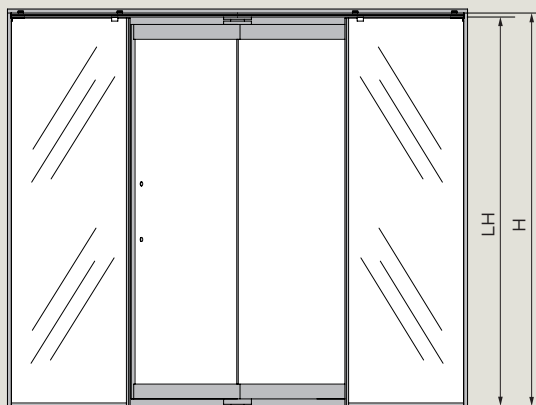

Dimensions KTV 4 ATRIUM

4-wing design (without night shield)					
Internal diameter (D)	2000	2200	2400	2600	2800
External diameter (B)	2048	2248	2448	2648	2848
Clear passage width (LW)	1379	1520	1661	1803	1944
4-wing design (with double-leaf external night shield)					
Internal diameter (D)	2000	2200	2400	2600	2800
External diameter (B)	2112	2312	2512	2712	2912
Clear passage width (LW)	1379	1520	1661	1803	1944

All dimensions in mm.

KTV 4 ATRIUM M/P/S

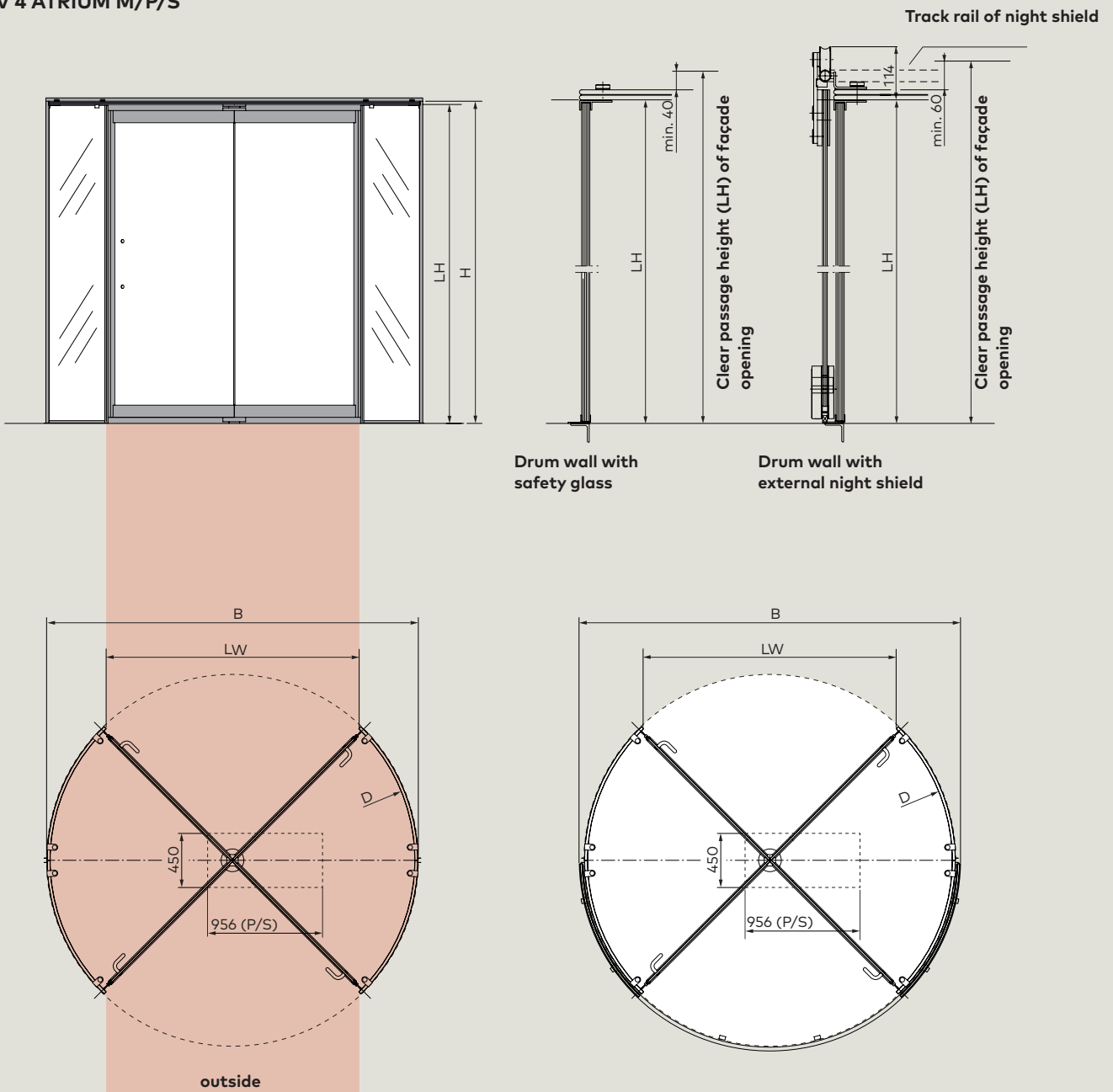

Dependency table

KTV A canopy height depending on function and installation features	
Function	Canopy height [mm]
Manual operation	100
Positioning automatic (canopy-integrated direct drive system)	
Servomatic (canopy-integrated direct drive system)	
Automatic (canopy-integrated direct drive system)	21.5* / 17.5* / 63*
Positioning automatic (underfloor operator)	
Servomatic (underfloor operator)	
Automatic (underfloor operator)	
Manual night shield	200
Electrically operated night shield	300
Speed limiter	100
Shock-Stop anti-vandalism brake (canopy-integrated operator)	200
Rainproof roof	
1. Metal roof / sheet metal cover	122
2. Roof prepared for rainproof covering (finishing work by roofing contractor required)	160
Overhead warm-air curtain	500/600

The highest indicated height defines the minimum canopy height.

Canopy height > 700 mm on request only.

Upper ceiling height is fixed on 100/200/300 mm (depending on door specification). Extended upper ceiling (= upper ceiling on same level as the canopy) is available as an option.

* For glass ceilings see product descriptions on pages 8/9

Dependency table for KTV 3/4 with framed turnstile

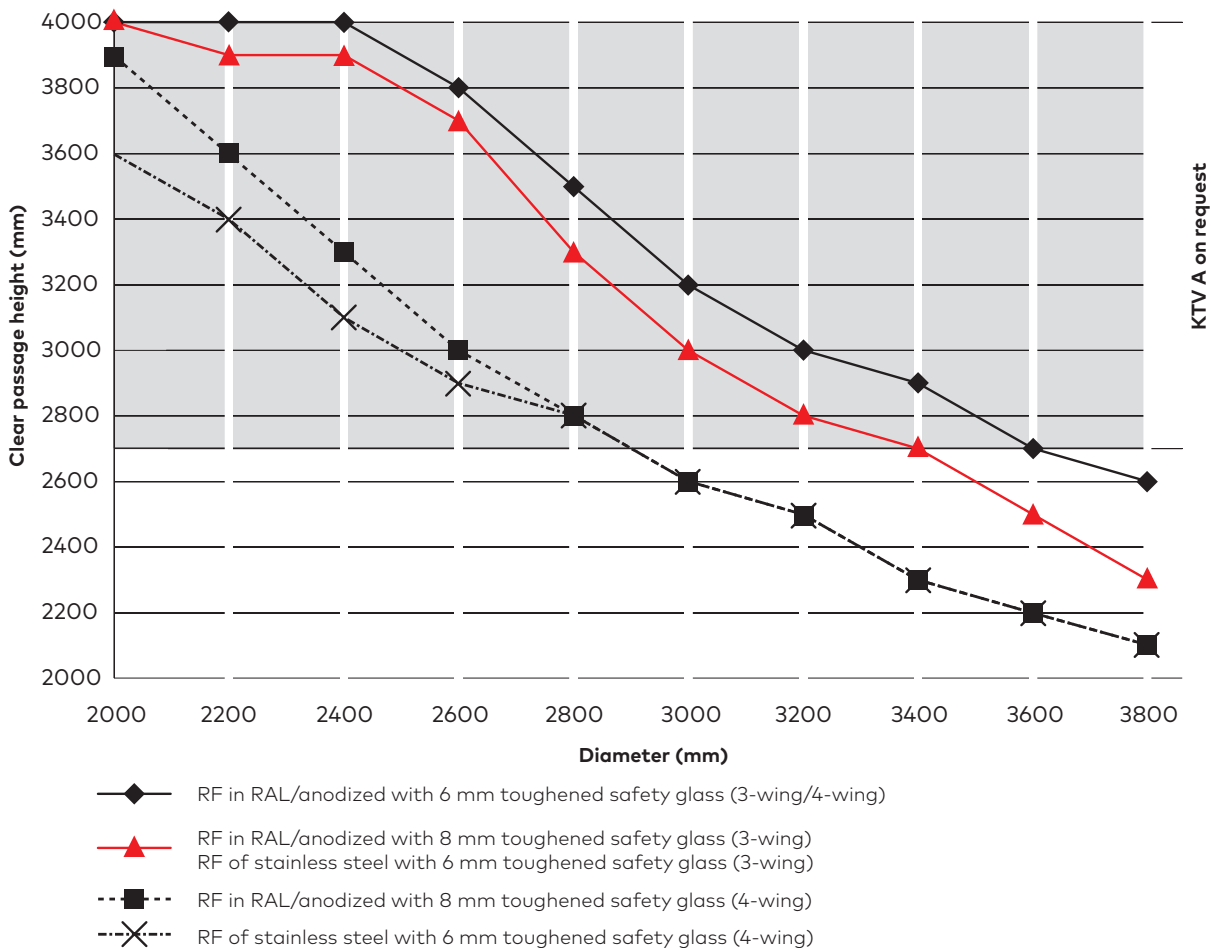

Dependency table KTV 3/4 with turnstile in fine-frame design

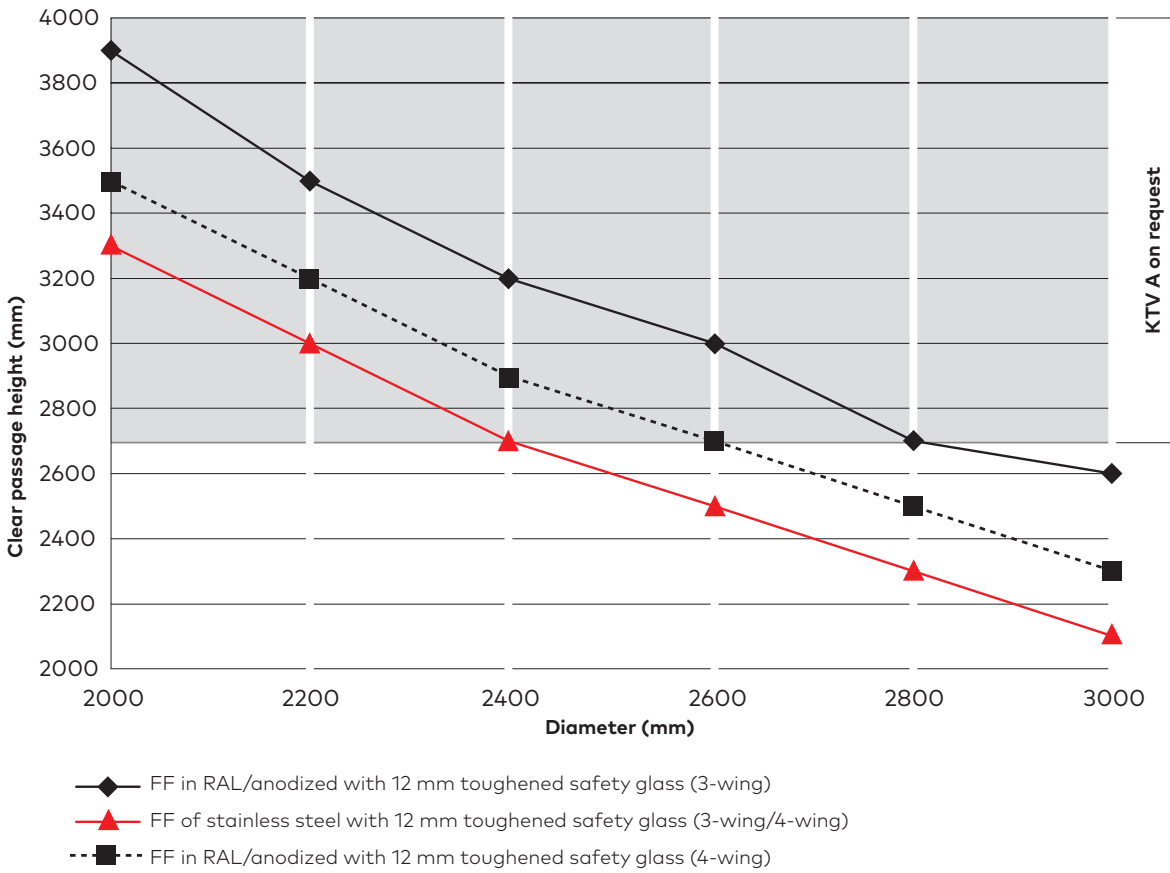

Dependency table KTV ATRIUM

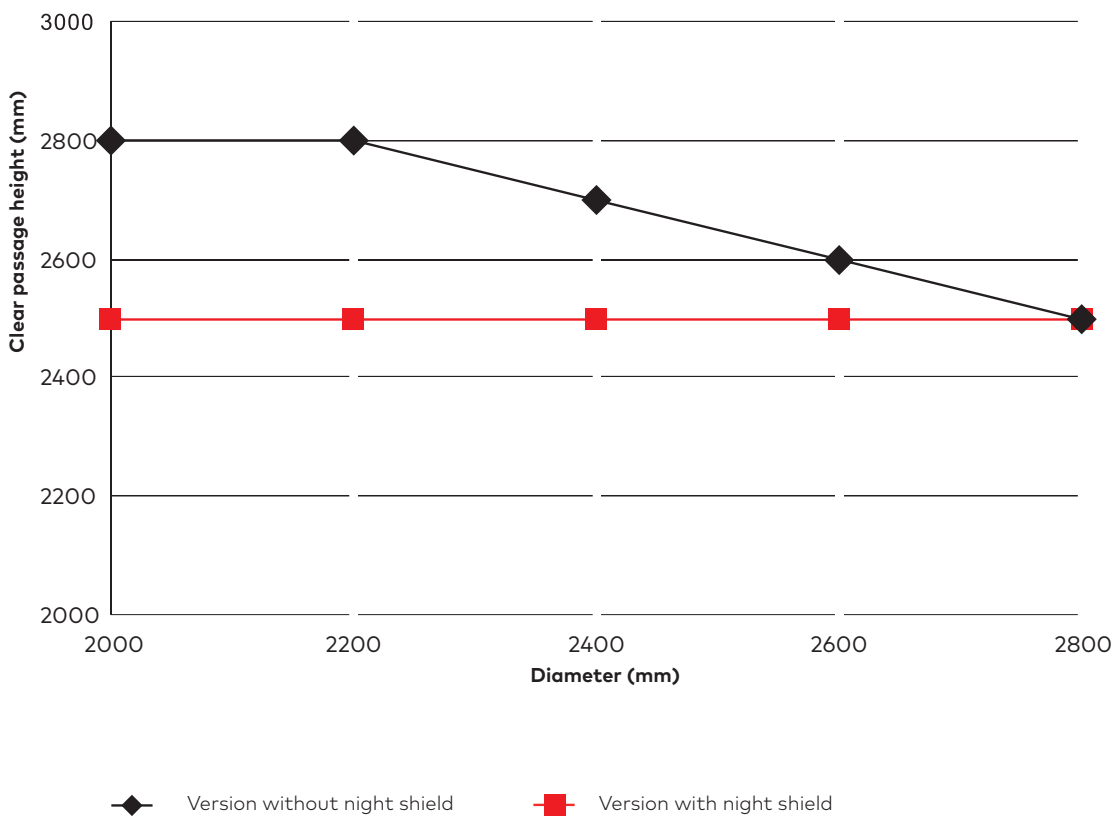

Turnstile versions

3-wing design

4-wing design

Framed turnstile, rigid

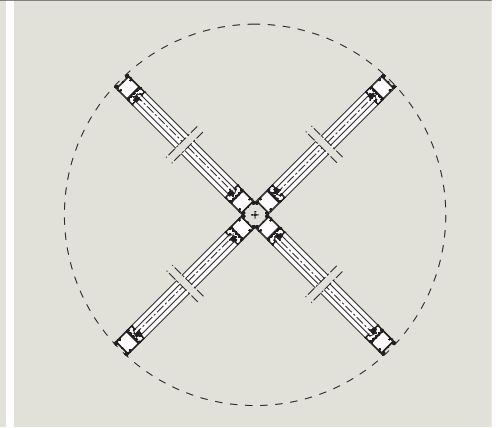
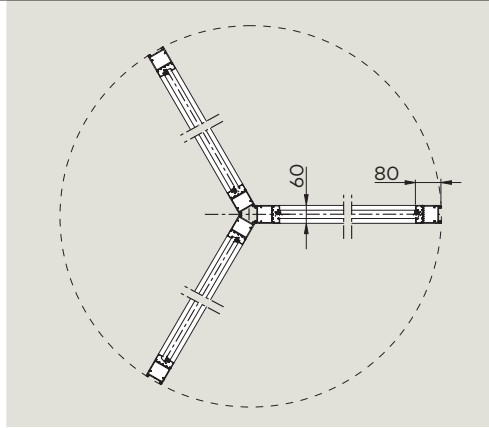

Framed turnstile with transport opening

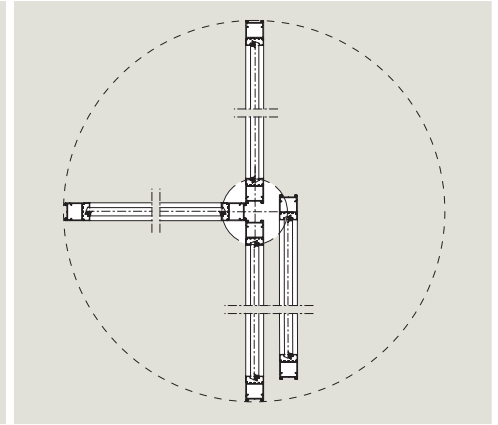
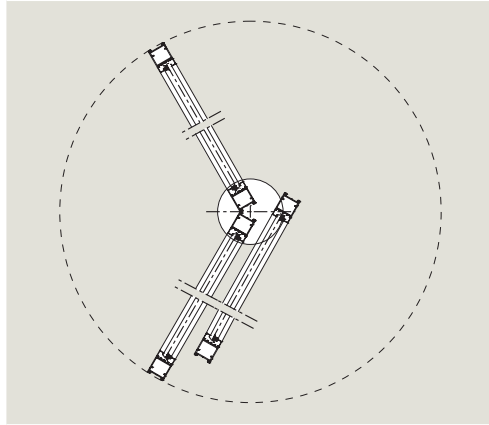

Framed turnstile with emergency escape configuration

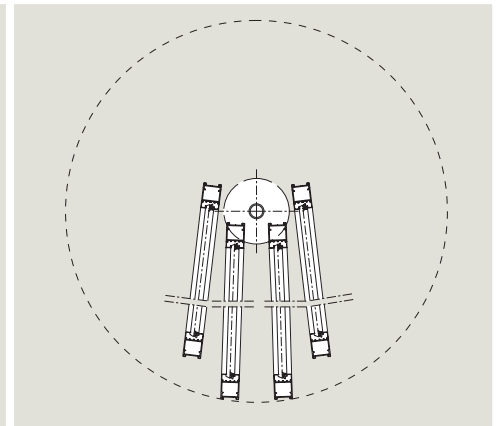
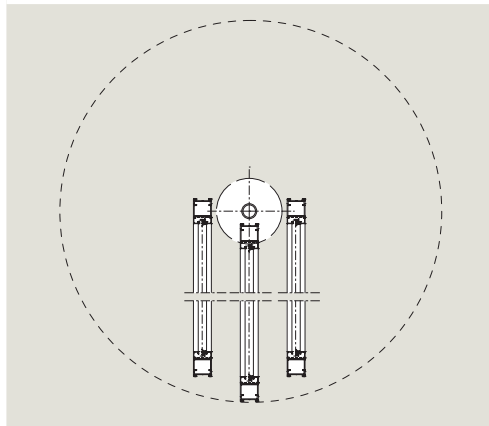

Rigid turnstile in fine-framed design

for internal diameters of max. 3000 mm

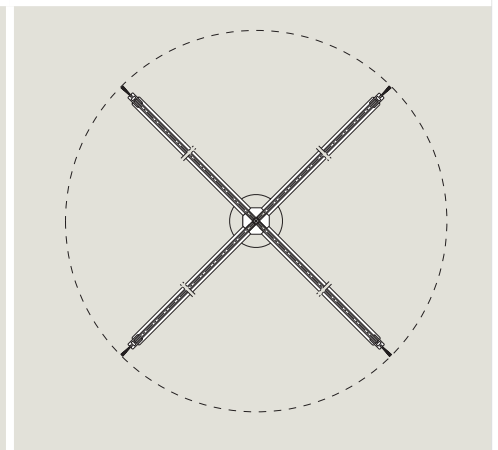
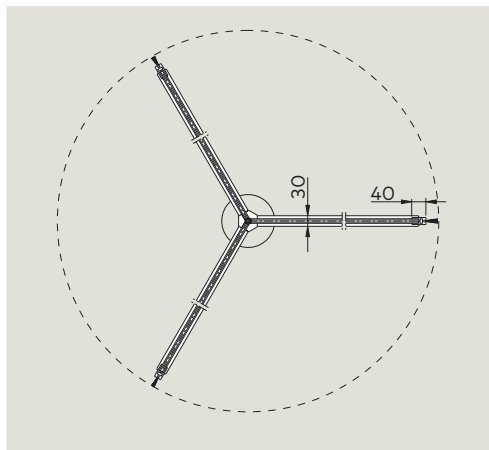

Wing locks

Manual locking device

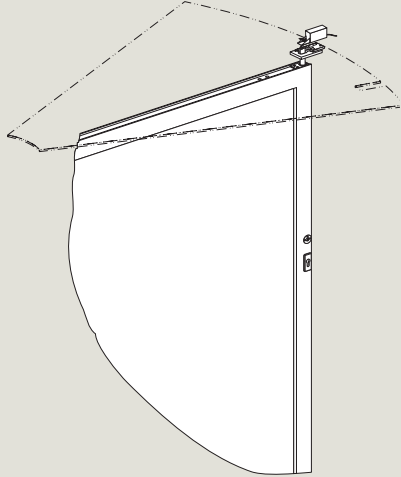

Electromechanical locking device

now also for KTV P and S in conjunction with the direct drive

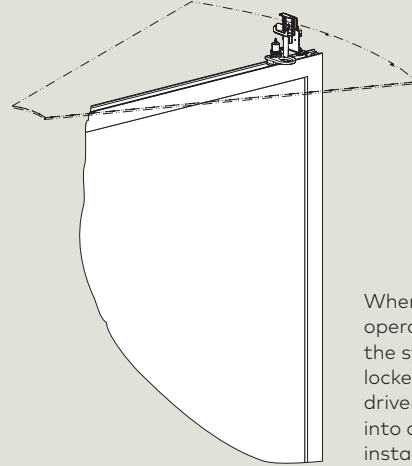

When the "off/locked" operating mode is activated, the system is rotated to the locked position and a motor-driven locking bolt is moved into a locking plate that is installed in the door wings.

Locking device for KTV with glass ceiling (framed wings)

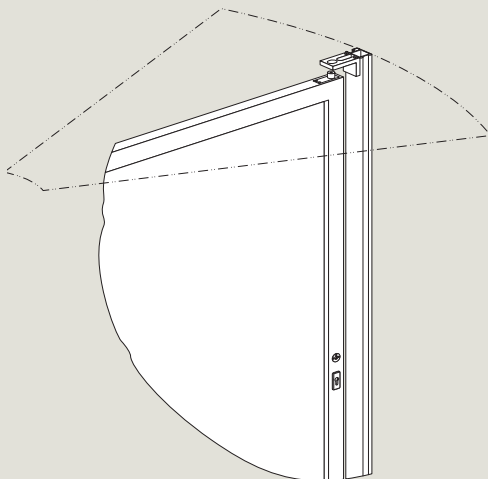

KTV floor locking device with glass ceiling, fine-frame wings

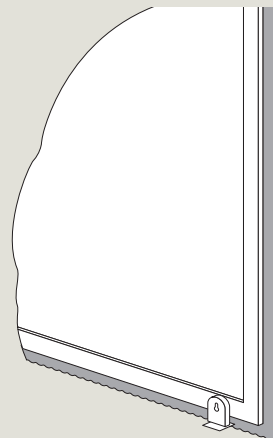

Shock-Stop*

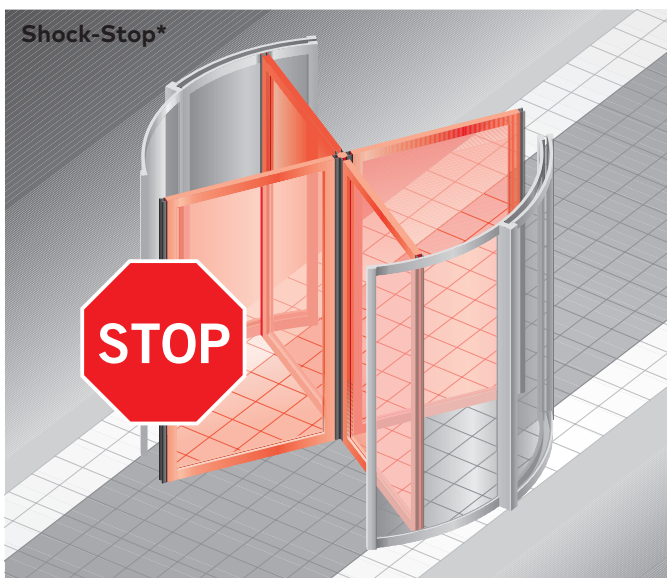

Shock-Stop*

The Shock-Stop function is able to lock the turnstile at any position. In the event of a power failure the turnstile is released and can be rotated in either direction (fail-safe design).

The Shock-Stop function can only be used with rigid wings and has a holding torque of 1200 Nm.

The activation button of the Shock-Stop function must be positioned within sight of the door.

* only in conjunction with conventional operator

Options

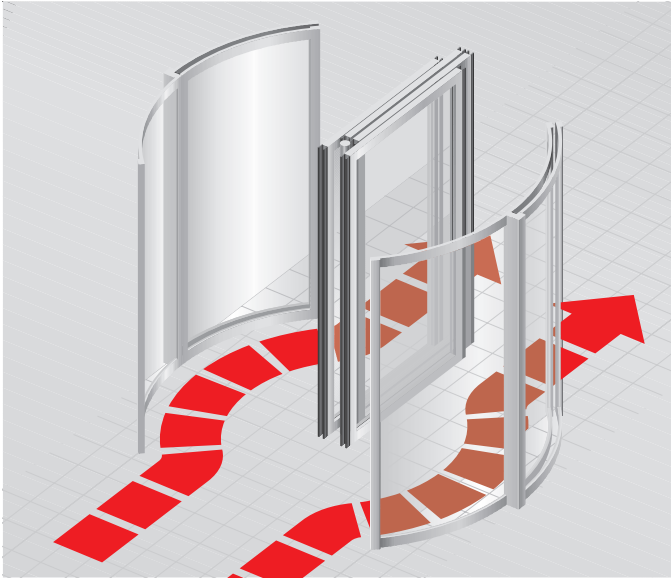

Escape route

The bookfold mechanism for the door wings offers a breakout function. The mechanism allows to fold the wings to an almost parallel position, offering the largest possible passage width. Depending on local regulations these doors can be suitable for installation in emergency exits and escape routes.

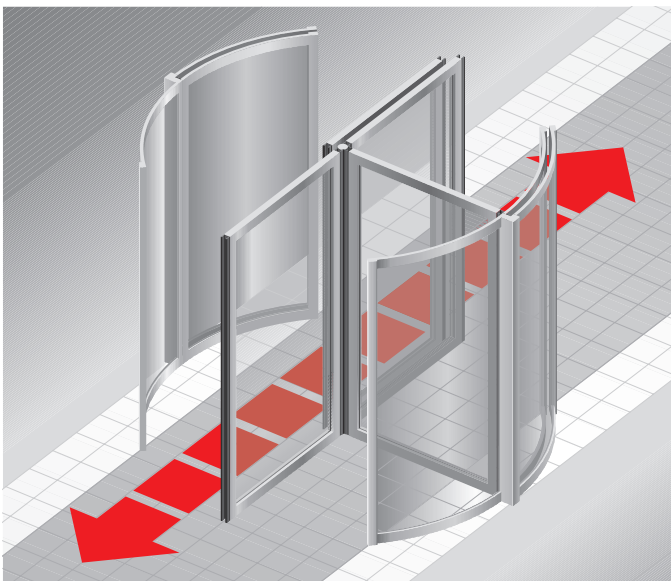

Transport opening

The hinged wing of the transport opening provides a special folding function for one wing (not available for KTV ATRIUM). Long or bulky objects can be carried through the door.

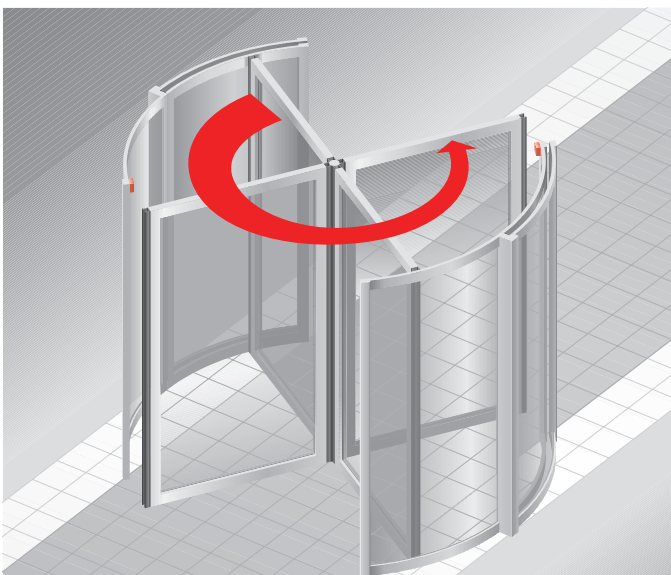

Speed limiter

The speed limiter is intended to avoid door rotation faster than a certain speed. The triggering speed and the intensity of the resistance can be adjusted. When the triggering speed is reached or exceeded, the turnstile is automatically slowed down, while still allowing to pass the door with an adequate walking speed (standard in conjunction with the direct drive).

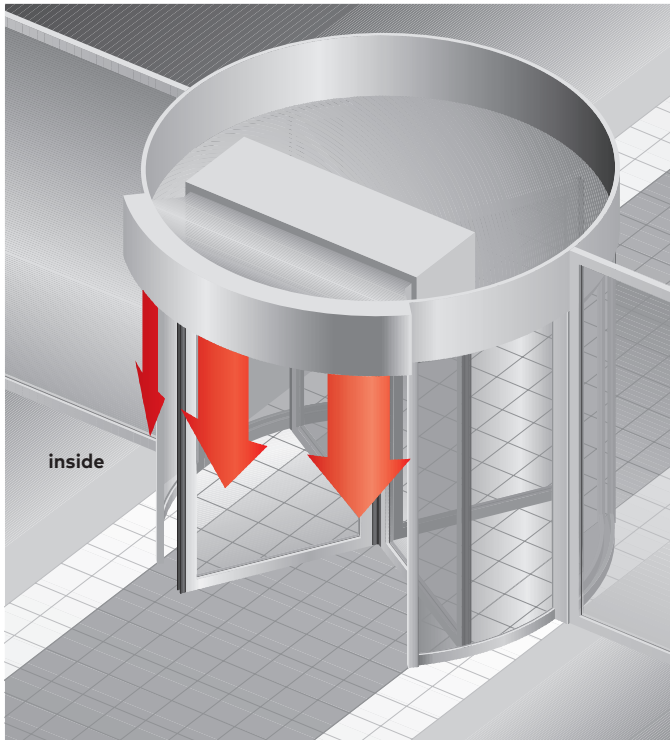

Warm-air curtain

The warm-air curtain unit consists of a self-supporting housing of zinc-plated steel.

The surfaces of the visible parts are powder-coated.

The exhaust duct – with nozzle matched to the radius of the revolving door – is provided at the opening with permanently fitted blades.

The air volume and speed are controlled with a remote control unit with switch and indicator light.

The device is mounted on the upper ceiling/roof. The exhaust duct is located in front of the internal canopy (in the passage area).

Technical data for a 4-wing revolving door with 3000 mm diameter and clear passage height of 2400 mm.

Air flow	3600 m ³ /h
Thermal output	25.8 kW
Heating medium	PWW 70/50 °C
Water resistance	2,44 kPa
Total current consumption	4.8 A
Motor capacity	1.1 kW
Voltage	230 V, 50 Hz
Max. sound level at 3 m distance	55 db(A)

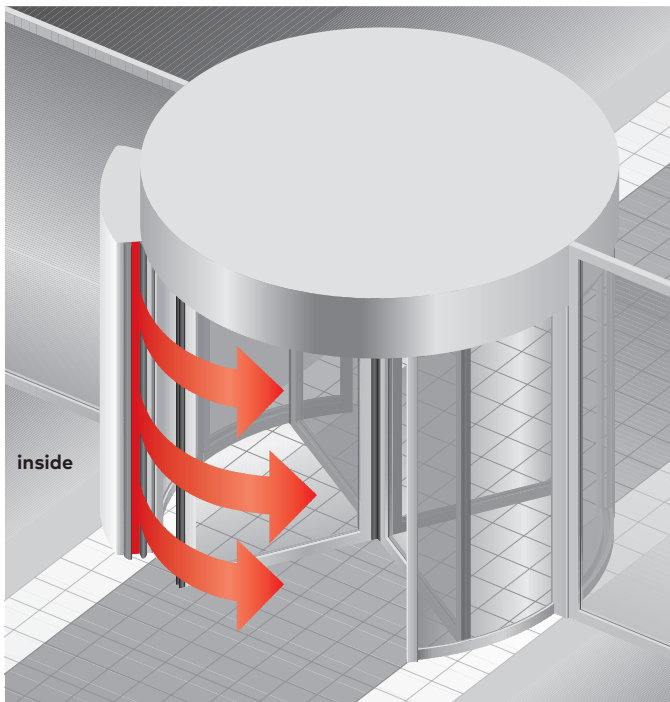

Vertical (floor mounted) warm-air curtain to blow air horizontally across the doorway

With low ceilings, you can also install a single or two vertical air-curtains. The performance is adapted to the door size.

Ceiling structure / Façade connection

Ceiling structure KTV 3/4

View of upper ceiling/roof:
Remains fixed even with
higher canopies

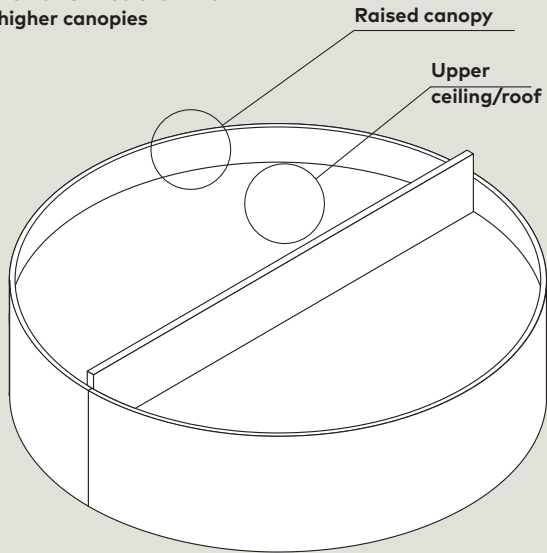

Lower ceiling of metal

Lower ceiling made of chipboard, melamine-coated (standard)

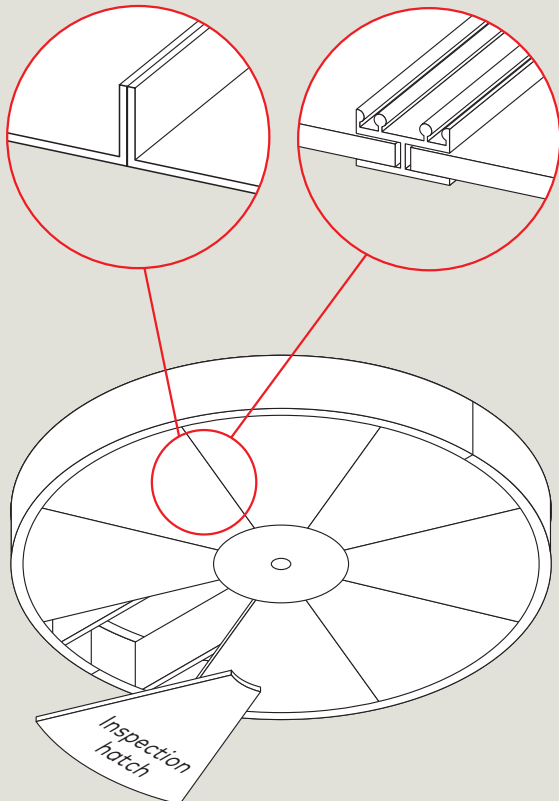

Façade connection KTV 3/4

Top façade connection

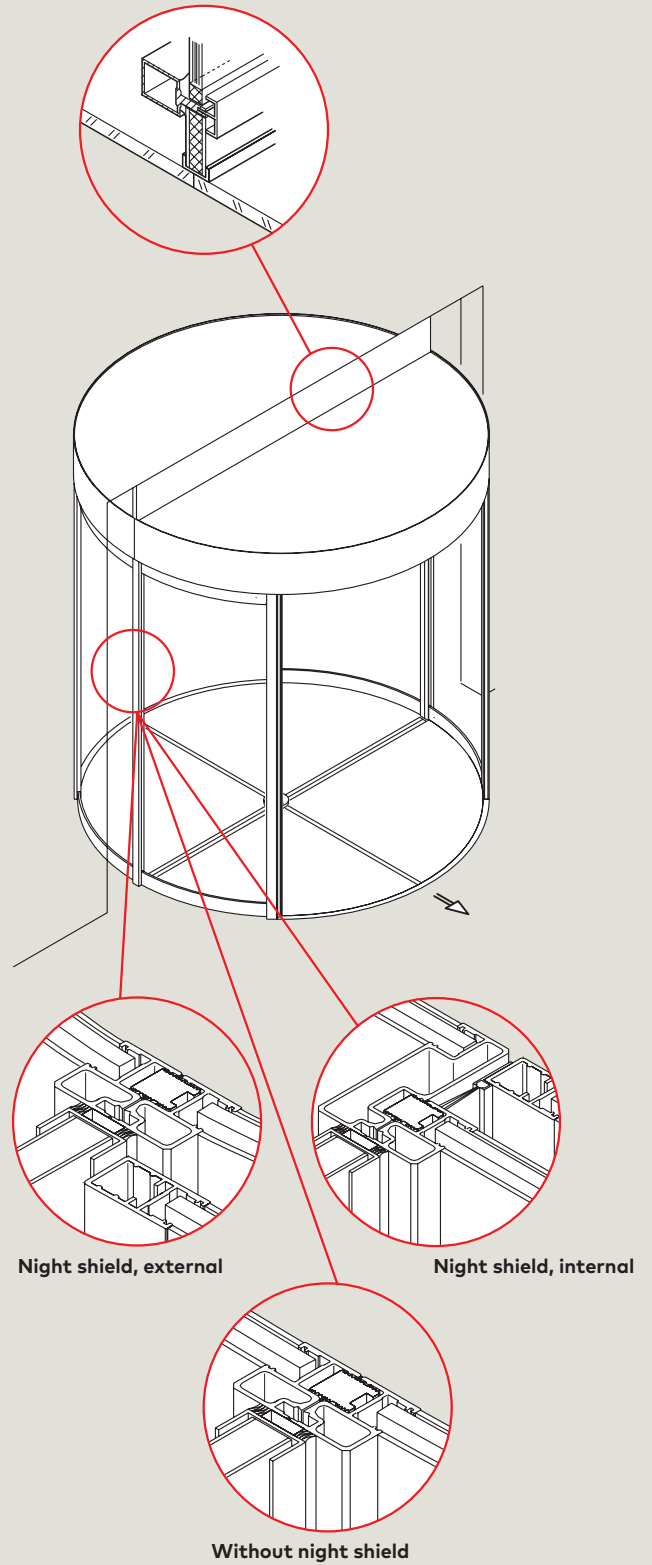

KTV with glass ceiling

Top façade connection

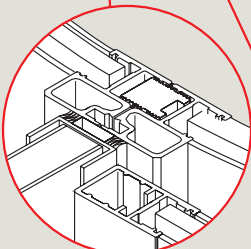
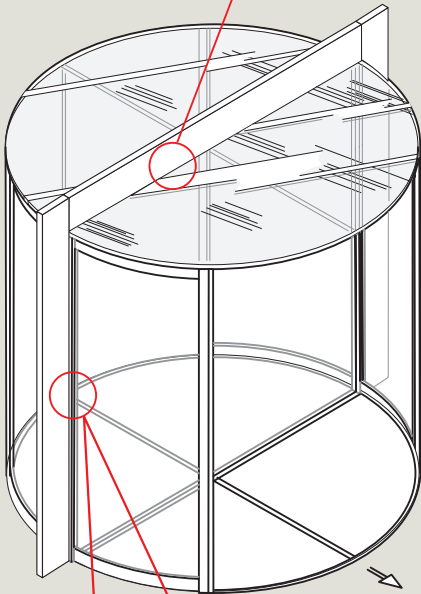
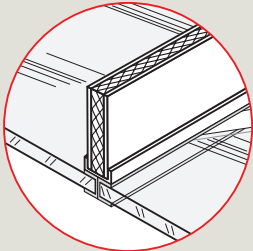

Night shield, external

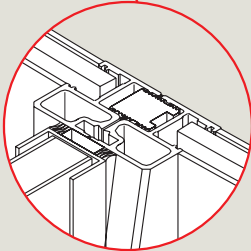

Without night shield

KTV ATRIUM

Top façade connection

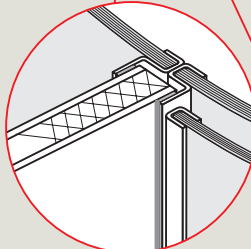
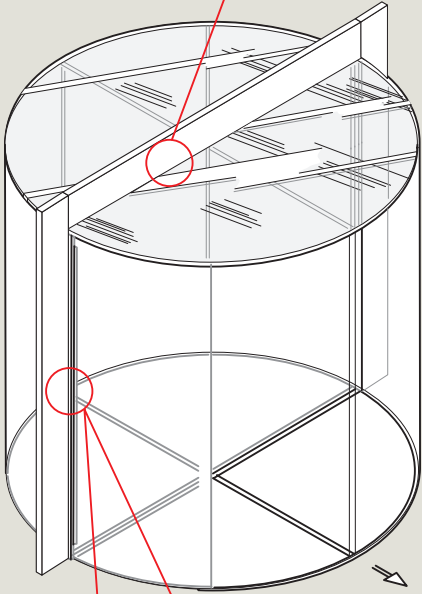
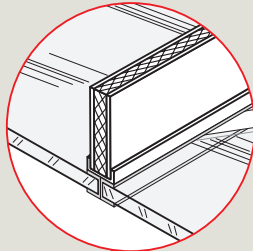

Night shield, external

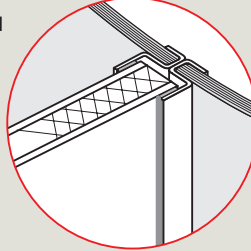

Without night shield

Floor ring

Standard floor ring types

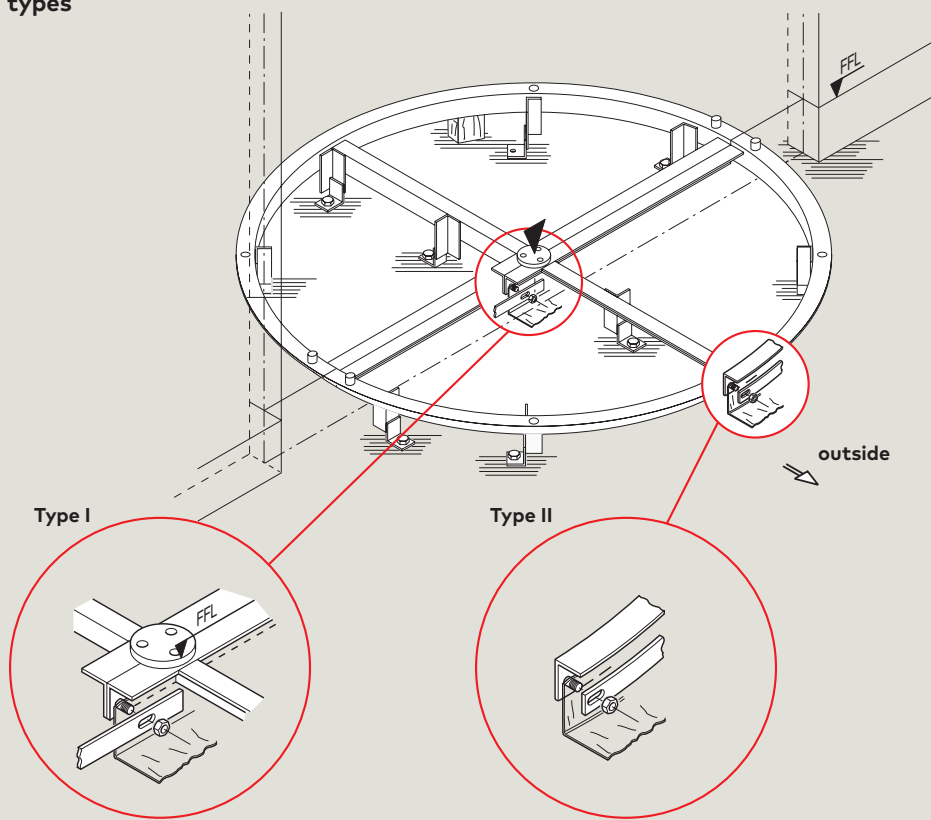

Floor ring without night shield

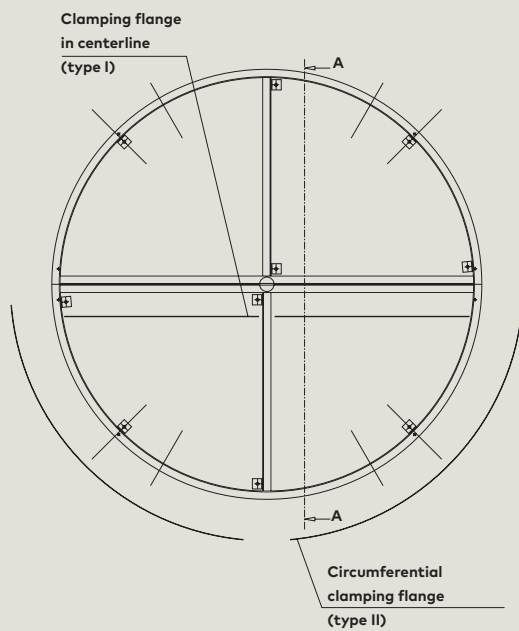

Cross-section A - A with clamping flange in centerline (type I)

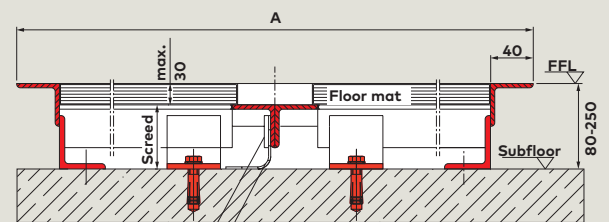

Clamping flange
Sheeting by others

A = 86 mm larger than internal diameter (D)

Cross-section A - A with sheeting flange, circumferential (type II)

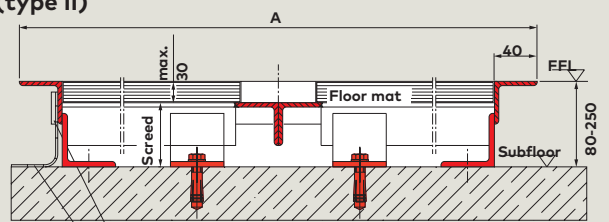

Clamping flange
Sheeting by others

A = 86 mm larger than internal diameter (D)

KTV with underfloor operator

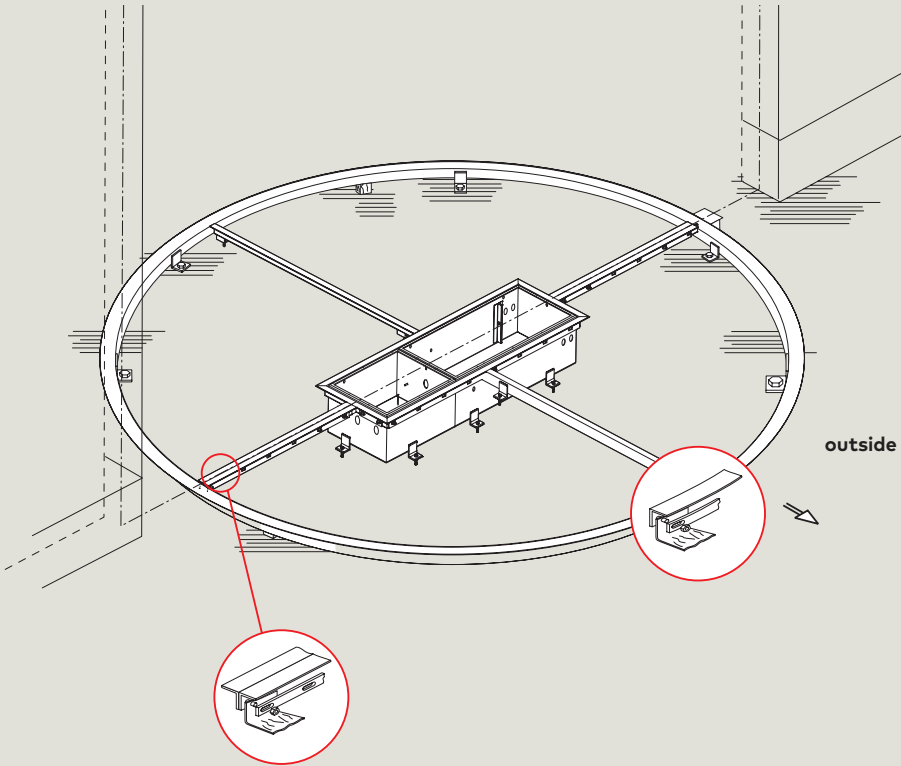

Floor ring with underfloor operator, without night shield

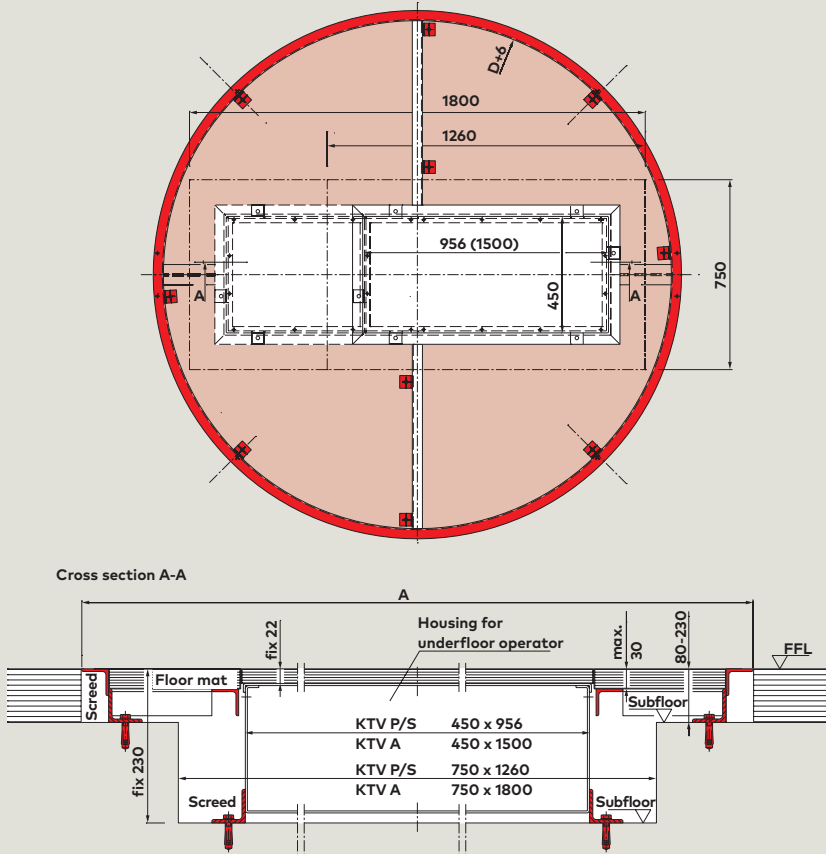

Wiring diagrams

Wiring diagram KTV P/S canopy-integrated operator

- External pushbutton for automatic night shield (option) 3 x 0.75 mm² (by others)
- Pushbutton for anti-vandalism brake (option) 2 x 0.7 5 mm² (by others)
- External program switch (option) 5 x 0.75 mm² (by others)
- Equipotential bonding of at least 6 mm² (by others)
- Power supply line 3 x 1.5 mm² (by others)

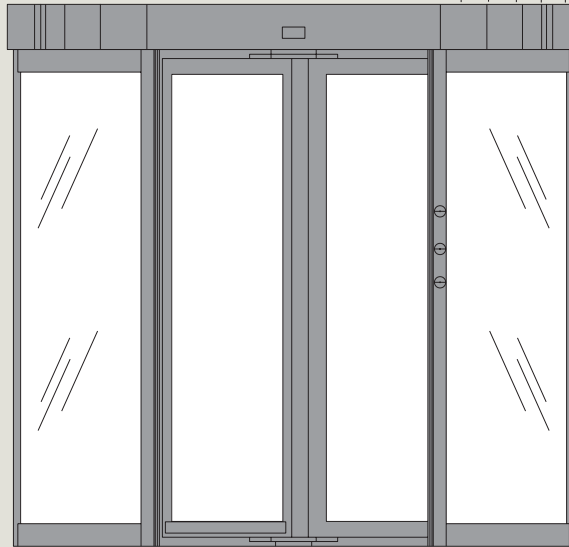

Wiring diagram KTV P/S underfloor operator

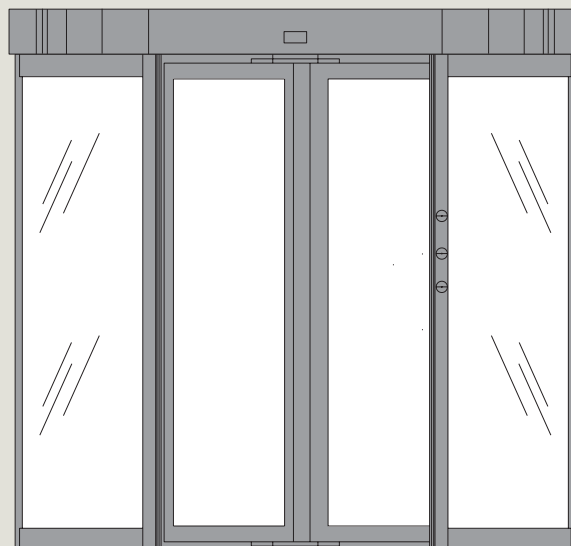

- External pushbutton for automatic night shield (option) 3 x 0.75 mm² (by others)
- Pushbutton for anti-vandalism brake (option) 2 x 0.7 5 mm² (by others)
- External program switch (option) 5 x 0.75 mm² (by others)
- Equipotential bonding of at least 6 mm² (by others)
- Power supply line 3 x 1.5 mm² (by others)

Wiring diagram KTV A canopy-integrated operator

- External pushbutton for automatic night shield (option) 3 x 0.75 mm² (by others)
- Potential-free contact for Night-/Bank Function (option) 2 x 0.75 mm² (by others)
- Pushbutton for anti-vandalism brake (option) 2 x 0.75 mm² (by others)
- External program switch (option) 5 x 0.75 mm² (by others)
- Equipotential bonding of at least 6 mm² (by others)
- Power supply line 3 x 1.5 mm² (by others)

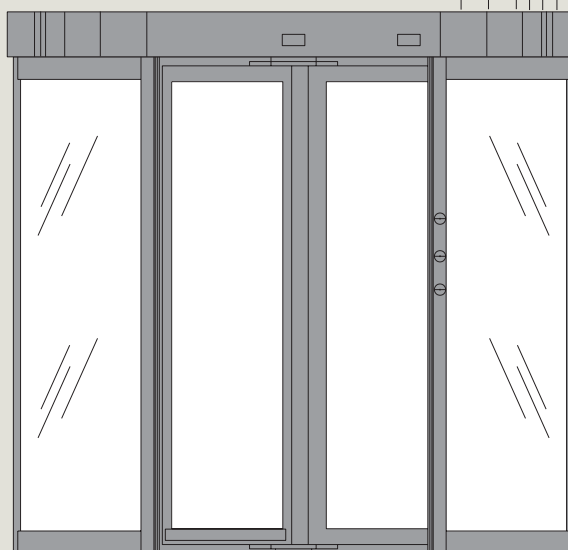

Wiring diagram KTV A underfloor operator

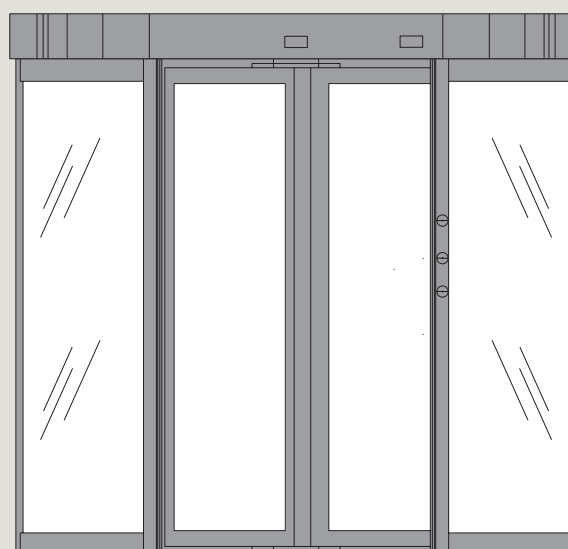

Drive + control unit

- External pushbutton for automatic night shield (option) 3 x 0.75 mm² (by others)
- Potential-free contact for Night-/Bank Function (option) 2 x 0.75 mm² (by others)
- Pushbutton for anti-vandalism brake (option) 2 x 0.75 mm² (by others)
- External program switch (option) 5 x 0.75 mm² (by others)
- Equipotential bonding of at least 6 mm² (by others)
- Power supply line 3 x 1.5 mm² (by others)

Dormatic (Malaysia) Sdn Bhd

Company No: 199001010853 (202423-X)

18, Jalan MJ/5, Taman Maju Jaya, Batu 7 Jalan Kelang Lama
46000 Petaling Jaya, Selangor Darul Ehsan, Malaysia

Tel: 03-7783 4500 / 7783 4548 Fax: 03-7782 8380

Email: dormatic@panmart.com

dormakaba 

dormakaba
Wilbury Way
Hitchin
Herts
SG4 0AB
T: 01462 477600
E: info.gb@dormakaba.com