

CONTENTS

Page

- 1 ▶ GENERAL INTRODUCTION

- 2-3 ▶ GUIDE OF TYPE SELECTION

- ▶ TECHNICAL DATA

- 4 - 6 ▶ Relevant parameter
- 6 - 7 ▶ Selection example
- 7 ▶ Motor connection
- 8 ▶ Performance parameter
- 9 ▶ Output torque of **IEC** input reducer
- 9 ▶ Performance table for combination of speed variator and **IEC** input reducer
- 10 ▶ Trait of the braking reducer and its application
- 11 ▶ Lubricant oil /quantity
- 11 ▶ Operating environment

- 12-19 ▶ OUTLINE DIMENSION SHEET

- 20 ▶ EXPLODED VIEW & NAME OF PARTS

- 21 ▶ CORRECT THE MALFUNCTION

STRUCTURE FEATURES

- Two types of housings: Aluminum alloy and cast iron; Two kinds of frames: foot mounting and flange mounting. They are good-looking in appearance, suitable for universal mount.
- Helical gear with the high-tensile alloy material makes the construction more compact, housing smaller, efficiency higher, output torque larger.
- Hardened facing transmission gear that fine finished has the advantages below: seldom distortion, high precision, stable running, low noise, It also can work continually under the dreadful conditions.
- With 6 specification for the diameter of output shaft: Ø18、Ø22、Ø28、Ø32、Ø40、Ø50.
- Two or three-stage transmission, large in ratio range, each single frame size with 14 ratios from 5:1 to 200:1.
- Using high quality bearing prolongs the use life.
- High-performance oil seal prevents the lubricant from leaking back to the inner of motor.
- Three-phase motor combined the standard and full-enclosed aluminum motor, which is good in waterproof, easy in heat dissipation, high in running efficiency.
- Modular combination extends the transmission ratio from $i=5:1$ to 1400:1.

SURFACE PAINTING

- Shot blasting firstly and then special antiseptic treatment on aluminum alloy surface (remain the metalline silver white; also is corrosion resistance to organic solvent, such as gasoline, xylene and so on).
- After phosphating, painted with blue and gray coating.

MODEL & MARK
G3 Series model reducer

G3 F M - 28 - 030 - T040
1
2
3
4
5
6









No	Comments
1	Model code
2	Mount mode 1). F : Flange mounted 2). L : Foot-mounted
3	Power mode 1). M : Standard model (motor without brake) 2). B : Brake model(motor with brake) 3). S : IEC input 4). Without character means shaft input
4	Output shaft diameter (Ø18; Ø22; Ø28; Ø32; Ø40; Ø50)
5	Speed ratio of reducer (i = 5; 10; 15; 20; 25; 30; 40; 50; 60; 80; 100;120; 160; 200)
6	Motor power (0.1; 0.20; 0.40; 0.75; 1.5; 2.2KW) 1). T : Three phase motor 2). Without T means single phase motor 3). (...) IEC Motor power

Combination of speed variator and and IEC input reducer

UDL - 075 - G3 F S - 28 - 030
1
2
3
4
5
6
7

No	Comments
1	Code of aluminium alloy casing speed variator
2	Motor power (0.18; 0.37; 0.75KW)
3	Model code
4	Mount mode 1). F : Flange mounted 2). L : Foot-mounted
5	S : Means IEC input
6	Output shaft diameter (Ø18; Ø22; Ø28; Ø32; Ø40; Ø50)
7	Speed ratio of reducer (i = 5; 10; 15; 20; 25; 30; 40; 50; 60; 80; 100;120; 160; 200)

SELECT THE REDUCER TYPE

	G3LM	Three-phase motor reducer with foot	page12
	G3FM	Three-phase motor reducer with flange	page13
	G3LS	IEC input reducer with foot	page14
	G3FS	IEC input reducer with flange	page15
	G3L	Shaft input reducer with foot	page16
	G3F	Shaft input reducer with flange	page17
	UDL-G3LS	Combination of speed variator and IEC input reducer with foot	page18
	UDL-G3FS	Combination of speed variator and IEC input reducer with flange	page19

NOTICE FOR ORDER

The customer should provide us the following information when you want to order G3 series reducers from our company:

- Basic parameters of reducer (including model code、mount mode、 motor mode、 output shaft diameter、 speed ratio、 motor power);
- Painting on outside body: the color of G3 series reducers and motors are painted with blue, also we can paint according to customer's request.

RELEVANT PARAMETER

1) Power

$$P_1 = \frac{P_2}{\eta} \text{ [kW]}$$

$$P_{1n} \geq P_1 \cdot f_s \text{ [kW]}$$

P₁ Input power

P₂ Output power

P_{1n} Selected motor power

f_s Service factor

η Transmission efficiency

G3 Series gear units transmission efficiency **η=95%**.

2) Rotation speed

n₁ Gear units input speed

n₂ Gear units output speed

which in selection table means the motor rotation speed 1400/min. If driven by the external gearing, 1400r/min or lower rotation speed is suggested so as to optimize the working conditions and prolong the service life. Higher input rotation speed is permitted, but in this situation, the rated torque **M₂** will be reduced.

 3) Transmission ratio **i**

$$i = \frac{n_1}{n_2}$$

Usually transmission ratio is decimal fraction with 2 radix point tagged in selection tables.

4) Torque

$$M_2 = \frac{9550 \cdot P_1 \cdot \eta}{n_2} \text{ [Nm]}$$

$$M_{2n} \geq M_2 \cdot f_s \text{ [Nm]}$$

M₂ Output torque

M_{2n} Selected output torque

P₁ Input power

η Transmission efficiency

f_s Service factor

 5) Service factor **f_s**

The effect of the driven machine on the gear unit is taken into account to a sufficient level of accuracy using the service factor **f_s**. The service factor is determined according to the daily operating time and the

starting frequency Z. Three load classifications are considered depending on the mass acceleration factor. You can read off the service factor applicable to your application in following Figure. The service factor selected using this diagram must be less than or equal to the service factor as given in the performance parameter table.

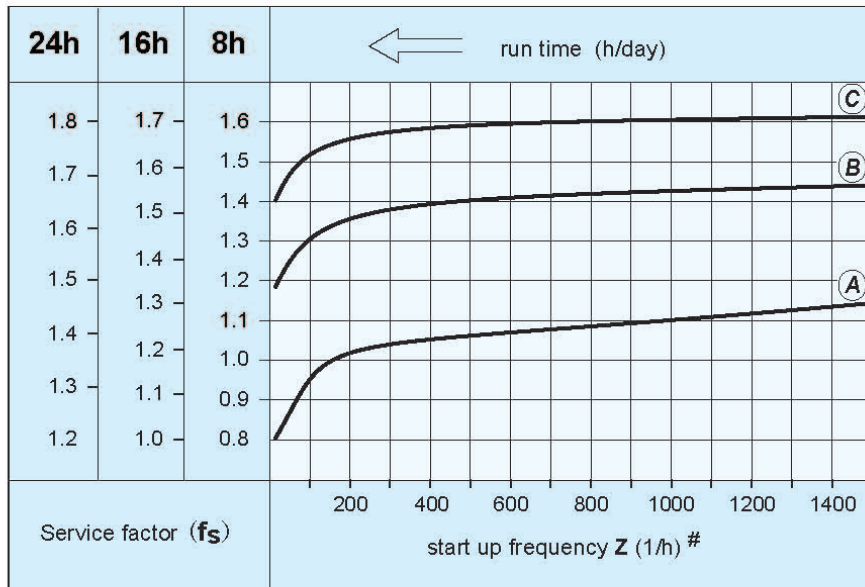

starting frequency Z: The cycles include all starting and braking procedures as well as change overs from low to high speed.

load classifications:

- (A) Uniform, permitted mass acceleration factor ≤ 0.2
- (B) Moderate shock load, permitted mass acceleration factor ≤ 3
- (C) Heavy shock load, permitted mass acceleration factor ≤ 10

Load classifications see the addendum.

The mass acceleration factor is calculated as follows:

$$f_a = \frac{J_c}{J_m}$$

- f_a** Mass acceleration factor
- J_c** All external mass moments of inertia (kgm²)
- J_m** Mass moment of inertia on the motor end (kgm²)

If mass acceleration factors $f_a > 10$, please call our Technical Service.

To keep the service-life of gear units, the use factor f_s selected from the catalogue must be equal or slightly higher than the calculated use factor f_s

6) Radial loads & axial loads F_{r2}

When determining the resulting radial loads, the type of transmission elements, mounted on the shaft end must be considered. Various transmission elements are corresponding with following transmission element factors f_z :

Transmission element	Transmission element factor F_z	Comments
Gears	1.00	≥ 17 teeth
	1.15	< 17 teeth
Chain sprockets	1.00	≥ 20 teeth
	1.25	< 20 teeth
	1.40	< 13 teeth
Narrow V-belt pulleys	1.75	Influence of the tensile force
Flat belt pulleys	2.50	Influence of the tensile force
Toothed belt pulleys	2.50	Influence of the tensile force

The overhung loads exerted on the motor or gear shaft is then calculated as follows:

$$F_{r2} = \frac{M_d \cdot 2000 \cdot f_z}{d_0} \text{ [N]}$$

F_{r2} Radial loads [N]

M_d Torque [Nm]

d_0 Mean diameter of the mounted transmission element [mm]

f_z Transmission element factor

SELECTION EXAMPLE

1) Gear motor

Example: Required power 1kW on driven machine, work for 8h/day, moderate shock load, so $f_s=1.3$, M6 foot-mounted, $n_2=47$ r/min

$$i = \frac{n_1}{n_2} = \frac{1400}{47} = 30$$

$$P_{1n} \geq P_1 \cdot f_s = \frac{P_2}{\eta} \cdot f_s = \frac{1}{0.95} \times 1.3 = 1.37 \text{ [kW]}$$

Choose type:

G3LM - 40 - 030 - T150

2) Gear units

Example: Reclured torquc 20Nm on driven machine, work 6h/day, uniform load, so $f_s=1.1, n_2=144$ r/min, flange-mounted, IEC input.

$$i = \frac{n_1}{n_2} = \frac{1400}{144} = 9.72$$

$$M_{2n} \geq M_2 \cdot f_s = 20 \times 1.1 = 22 \text{ [Nm]}$$

$$P_{1n} \geq P_1 \cdot f_s = \frac{M_2 \cdot n_1}{9550 \cdot \eta \cdot i} \cdot f_s = \frac{20 \times 1400}{9550 \times 0.95 \times 9.72} \times 1.1 = 0.349 \text{ [kW]}$$

Choose type:

G3FS - 22 - 010 - (037)

MOTOR CONNECTION

There are six connection poles on the motor's connection board, when selecting starlike and triangle connection, three phase pressure inputted will be different(as following drawing shows), if you exchange any two lines, the reducer will reverse.

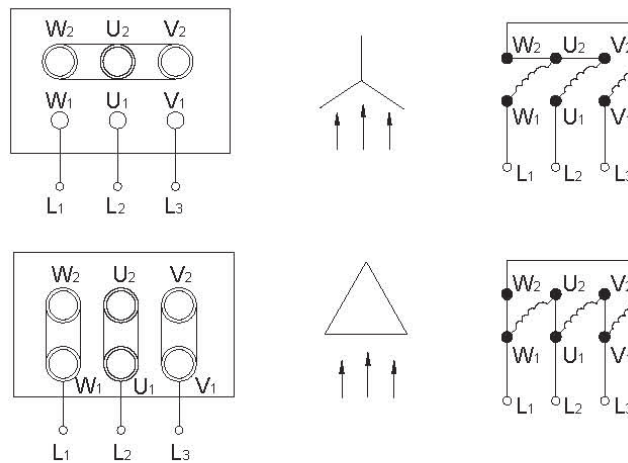

PERFORMANCE PARAMETER

Normal ratio		5	10	15	20	25	30	40	50	60	80	100	100	120	160	200	
0.1kW	output shaft	∅18								∅22							
	actual speed ratio	4.97	10.12	15.16	20.08	24.89	30.46	40.11	50.14	62.17	79.12	98.18	-	122.27	155.62	194.52	
	n ₂ * (1/min)	282	138	92	70	56	46	35	28	23	18	14	-	11	9	7	
	M ₂ (Nm)	50Hz	3.2	6.5	9.8	12.9	16.1	19.6	25.7	31.1	37.5	49.5	62.9	-	76.1	100.7	125.4
		60Hz	3	5	8	11	13	17	21	26	31	41	52	-	63	84	105
	Fr ₁ (N)	588	882	980	1180	1270	1370	1470	1570	2160	2450	2450	2450	2450	2450	2450	2450
Fr ₂ (N)	176																
0.2kW	output shaft	∅18						∅22						∅28			
	actual speed ratio	4.97	10.12	15.16	20.08	24.89	30.86	39.56	49.09	62.17	79.12	98.18	104.08	120.88	165	196.43	
	n ₂ * (1/min)	282	138	92	70	56	45	35	29	23	18	14	13	12	8	7	
	M ₂ (Nm)	50Hz	6.5	12.6	19.1	26.3	32.6	38.9	50.4	63	75.6	100.8	103.9	125.40	150	200.4	250.7
		60Hz	5.4	10.5	16.6	21.9	27.1	32.4	42	52.5	63	84	86.6	104.50	125	167	208.9
	Fr ₁ (N)	588	882	980	1180	1270	1760	1860	1960	2160	2450	2450	2840.00	3330	3430	3430	
Fr ₂ (N)	196																
0.4kW	output shaft	∅22						∅28						∅32			
	actual speed ratio	4.86	9.71	15.27	19.43	24.29	30	38.96	48.29	58.22	79.48	98.51	98.29	121.56	158.48	202.5	
	n ₂ * (1/min)	288	144	92	72	58	47	36	29	24	18	14	14	12	9	7	
	M ₂ (Nm)	50Hz	12.9	25	38.6	51.4	65.4	78.2	100.7	125.4	150	200.4	206.8	250.70	301.1	400.7	461.8
		60Hz	10.7	20.8	32.1	42.9	54.5	65.2	83.9	104.5	125.0	167.0	172.3	208.9	250.9	333.9	384.8
	Fr ₁ (N)	882	1180	1370	1470	1670	2550	2840	3140	3430	3430	3430	3430	4900	5880	5880	5880
Fr ₂ (N)	245																
0.75kW	output shaft	∅28						∅32						∅40			
	actual speed ratio	5.04	10	14.95	20.4	24.29	30.67	39.69	49.09	59.54	79.38	98.18	98.90	122.08	155.56	194.44	
	n ₂ * (1/min)	278	140	94	69	58	46	35	29	24	18	14	14	11	9	7	
	M ₂ (Nm)	50Hz	24.6	48.2	72.9	97.5	122.1	145.7	187.5	235.7	282.9	376.1	387.9	439	527	703	764
		60Hz	20.5	40.2	60.7	81.3	201.8	121.4	156.3	196.4	235.7	313.4	323.2	366	439	585	732
	Fr ₁ (N)	1270	1760	2160	2350	2450	4020	4210	4610	5490	5880	5880	7060	7060	7060	7060	
Fr ₂ (N)	294																
1.5kW	output shaft	∅32						∅40						∅50			
	actual speed ratio	5	10	15	20	25.56	30	41.54	51.27	59.34	83.08	102.55	104.72	116.79	165.88	194.37	
	n ₂ * (1/min)	280	140	93	70	55	47	34	27	24	17	14	13	12	8	7	
	M ₂ (Nm)	50Hz	48.2	97.5	145.7	193.9	242.1	272	351	439	527	703	724	878	1060	1230	1230
		60Hz	40.2	81.3	121.4	161.6	201.8	226	293	366	439	585	603	732	878	1170	1230
	Fr ₁ (N)	1760	2450	2840	3230	3820	5100	5880	7060	7060	7060	7060	9800	9800	9800	9800	
Fr ₂ (N)	343																
2.2kW	output shaft	∅40						∅50									
	actual speed ratio	5.14	10.29	14.69	20.57	25.71	30.8	38.82	50.73	59.27	77.45	100.76					
	n ₂ * (1/min)	272	136	95	68	54	45	36	28	24	18	14					
	M ₂ (Nm)	50Hz	67	133	200	266	332	399	515	644	773	1029	1230				
		60Hz	56	111	167	221	277	332	429	537	644	858	1080				
	Fr ₁ (N)	2160	3140	3530	4020	4700	6960	7250	8620	9800	9800	9800					
Fr ₂ (N)	392																

 (" * " : n₁ = 1400r / min 50Hz)

IEC OUTPUT TORQUE OF IEC INPUT REDUCER

Normal ratio		5	10	15	20	25	30	40	50	60	80	100	100	120	160	200	
0.12kW	output shaft	Ø18									Ø22						
	M ₂ (Nm)	50Hz	3.9	7.8	11.7	15.4	19.3	23.5	30.9	37.3	45.0	59.4	75.5	—	91.3	120.9	150.4
		60Hz	3.2	6.5	9.8	12.9	16.1	20.4	25.7	31.1	37.5	49.5	62.9	—	76.1	100.7	125.4
0.18kW	output shaft	Ø18					Ø22					Ø28					
	M ₂ (Nm)	50Hz	5.9	11.4	17.2	23.6	29.3	35	45.3	56.7	68.1	90.7	93.5	112.8	135	180.3	225.6
		60Hz	4.9	9.5	14.9	19.7	24.4	29.2	37.8	47.3	56.7	75.6	77.9	94	112.5	150.3	188
0.37kW	output shaft	Ø22					Ø28					Ø32					
	M ₂ (Nm)	50Hz	11.9	23.1	35.7	47.6	60.5	72.3	93.2	116	138.8	185.3	191.3	231.9	278.5	370.7	427.2
		60Hz	9.9	19.2	29.7	39.6	50.4	60.3	77.6	96.6	115.6	154.4	159.4	193.3	232.1	308.9	356
0.75kW	output shaft	Ø28					Ø32					Ø40					
	M ₂ (Nm)	50Hz	24.6	48.2	72.9	97.5	122.1	145.7	187.5	235.7	282.9	376.1	387.9	439	527	703	764
		60Hz	20.5	40.2	60.7	81.3	201.8	121.4	156.3	196.4	235.7	313.4	323.2	366	439	585	732
1.5kW	output shaft	Ø32					Ø40					Ø50					
	M ₂ (Nm)	50Hz	48.2	97.5	145.7	193.9	242.1	272	351	439	527	703	724	878	1060	1230	1230
		60Hz	40.2	81.3	121.4	161.6	201.8	226	293	366	439	585	603	732	878	1170	1230
2.2kW	output shaft	Ø40					Ø50										
	M ₂ (Nm)	50Hz	67	133	200	266	332	399	515	644	773	1029	1230				
		60Hz	56	111	167	221	277	332	429	537	644	858	1080				

PERFORMANCE TABLE FOR COMBINED OF SPEED VARIATOR AND IEC INPUT REDUCER

motor & rev	Model	i	n2 r/min	M2 N.M	motor & rev	Model	i	n2 r/min	M2 N.M	
0.18kw 4P n1=1400r/min	UDL0.18-G3-18	5	34.4 ~ 176	7.5 ~ 36.1	0.37kw 4P n1=1400r/min	UDL0.37-G3-28	60	3.4 ~ 17.2	167 ~ 755	
		10	16.9 ~ 86.3	15.3 ~ 73.6			80	2.5 ~ 12.6	228 ~ 1030	
		15	11.3 ~ 57.7	23 ~ 110			100	2 ~ 10.2	283 ~ 1277	
		20	8.5 ~ 43.6	30.4 ~ 146		UDL0.37-G3-32	100	2 ~ 10.2	282 ~ 1274	
		25	6.8 ~ 35.2	37.7 ~ 181			120	1.6 ~ 8.2	349 ~ 1576	
	30	5.5 ~ 28.4	46.8 ~ 224	160			1.3 ~ 6.3	455 ~ 2055		
	40	4.3 ~ 22.1	59.9 ~ 288	200			1 ~ 4.9	581 ~ 2625		
	UDL0.18-G3-22	50	3.5 ~ 17.8	74.4 ~ 357		0.75kw 4P n1=1400r/min	UDL0.75-G3-28	5	39.7 ~ 198	29.3 ~ 132
		60	2.7 ~ 14.1	64.2 ~ 452				10	20 ~ 100	58.2 ~ 263
		80	2.2 ~ 11.1	120 ~ 575				15	13.4 ~ 66.9	87 ~ 393
		100	1.7 ~ 8.9	149 ~ 714				20	9.8 ~ 49	119 ~ 536
		100	1.6 ~ 8.4	158 ~ 757				25	8.2 ~ 41.2	141 ~ 638
	UDL0.18-G3-28	120	1.4 ~ 7.2	183 ~ 877			UDL0.75-G3-32	30	6.5 ~ 32.6	178 ~ 806
		160	1 ~ 5.3	250 ~ 1199				40	5 ~ 25.2	231 ~ 1043
200		0.9 ~ 4.5	298 ~ 1428	50	4.1 ~ 20.4			287 ~ 1290		
5		41.2 ~ 206	13.9 ~ 63	60	3.4 ~ 16.8			346 ~ 1565		
0.37kw 4P n1=1400r/min	UDL0.37-G3-22	10	20.6 ~ 103	27.9 ~ 126	80			2.5 ~ 12.6	462 ~ 2086	
		15	13.1 ~ 65.5	43.8 ~ 198	100			2 ~ 10.2	571 ~ 2580	
		20	10.3 ~ 51.5	55.8 ~ 250						
		25	8.2 ~ 41.2	69.7 ~ 315						
	UDL0.37-G3-28	30	6.7 ~ 33.3	86.1 ~ 389						
		40	5.1 ~ 25.7	112 ~ 505						
		50	4.1 ~ 20.7	139 ~ 625						

TRAIT OF THE BRAKING REDUCER AND ITS APPLICATION

Braking reducer is the reducer with brake motor. The motor brake apparatus consists of spring, lining, brake plate, rectifier and winding. It realizes running upon power-on condition while braking upon power-off condition. The integrated design of the motor and brake makes the configuration compact; The lining, which uses the imported and high-efficient non-asbestos material, is wearable during high-frequency usage, and low in wear rate, also environment-protected. It can be used more than 1,000,000 times; the rectifier actualizes the controlling motor starting and emergency stop by a switch; and it is short in response time. The hard facing helical gear reducer with a longevity usage is suitable to be applied on the automatic occasion such as high braking frequency, emergency stop and starting.

CHARACTERISTICS TABLE





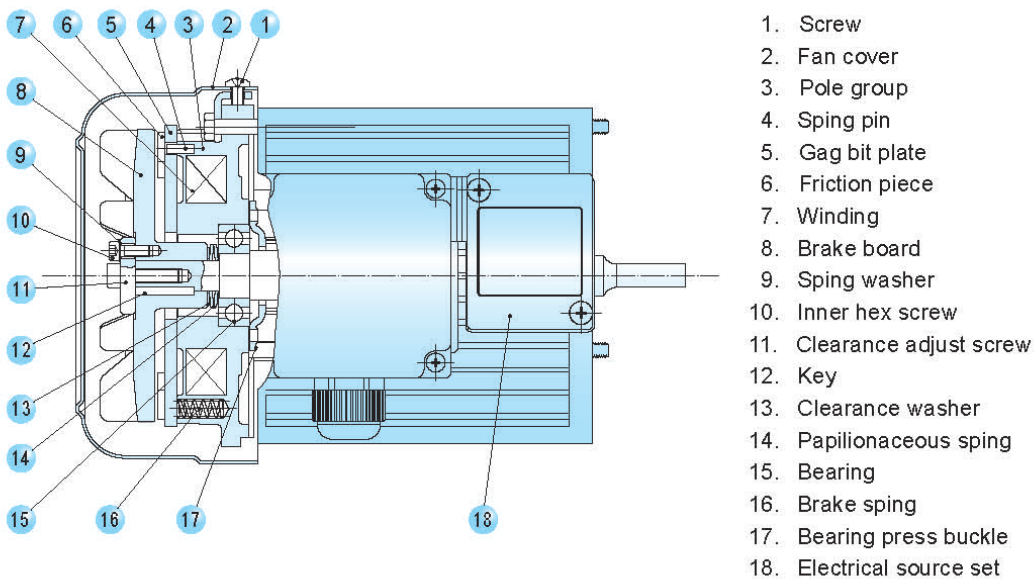

power (KW)	rated torque (Nm)	excitation pressure (V)	excitation power (W)	clearance adjust workload (J)	overall workload (J)	magnetize time (ms)	release time (ms)	clearance	
								stated value (mm)	limited value (mm)
0.2	2	90	20	9×10^7	45×10^7	30	80	0.3	0.7
0.4	4	90	26	15×10^7	75×10^7	30	100	0.3	0.7
0.75	8	90	39.4	30×10^7	100×10^7	60	120	0.3	1
1.5	15	90	48	30×10^7	100×10^7	90	140	0.4	1
2.2	30	90	52.2	50×10^7	160×10^7	90	150	0.4	1

BRAKE STRUCTURAL VIEW

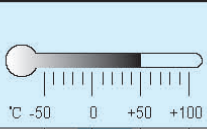

G3 series reducers are supplied with lubricant, synthetic oil, SHELL Alvania GL00 before delivery, It doesn't need to replace lubricant for first 20,000 hours running, But if works in special application, Such as high temperature, long-time running heavy impact load, It should be changed every 10,000-15,000 working hours.

LUBRICANT GREASE

								
	°C -50 0 +50 +100	ISO	SHELL	MOBIL	BP	意格爾	GF	
G3...	Standard -15 +40	000 - 0	Alvania GL 00	Mobilux EP 00	Energrease LS-EP 00	8125A 00		Synthetic oil
	-25 +60	00	Tivela GL 00	Glygoyle Grease 00				Synthetic oil
UDL ...	-25 +40	VG32	A.T.F.DXRON	A.T.F.220	Autran DX		Ub3	Mineral oil

QUANTITY OF LUBRICANT

output shaft	Ø18	Ø22	Ø28	Ø32	Ø40	Ø50
quantity of lubricant (g)	140	200	400	600	900	1600

APPLICATION ENVIRONMENT :

Ambient temperature between -10°C to 40°C, Ambient humidity below 85%RH, the altitude below 1,000m, no corrosive and explosive gas or liquid or dust, mounted in indoor.

G3LM THREE-PHASE MOTOR REDUCER WITH FOOT

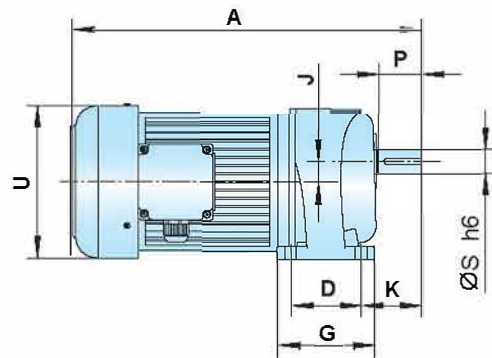
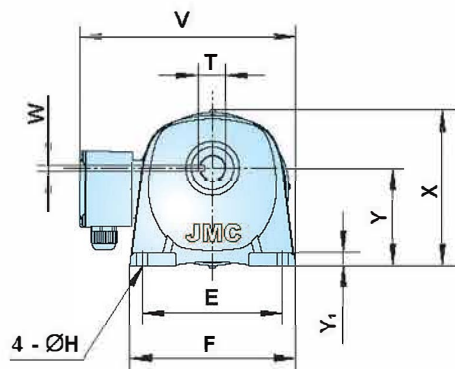
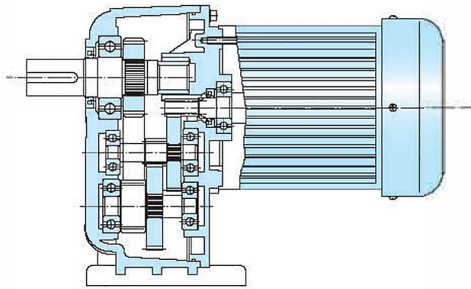

motor rotate speed 1400 r / min

power kW	output shaft	ratio	primary outline and dimension-mount																	
			A		D	E	F	J	G	H	K	P	S	T	U	V	W	X	Y	Y ₁
			standard	brake																
0.1	Ø18	5,10,15,20,25,30,40,50	236	270	40	110	135	16.5	65	9	45	30	18	20.5	129	183	6	133	85	10
	Ø22	60,80,100,120,160,200	262	296	65	130	155	19	90	11	55	40	22	24.5	129	193	6	139.5	90	12
0.2	Ø18	5,10,15,20,25	267	270	40	110	135	16.5	65	9	45	30	18	20.5	129	183	6	133	85	10
	Ø22	30,40,50,60,80,100	293	296	65	130	155	19	90	11	55	40	22	24.5	129	193	6	139.5	90	12
	Ø28	100,120,160,200	306	309.5	90	140	175	23.5	125	11	65	45	28	31	129	203	8	170	110	15
0.4	Ø22	5,10,15,20,25	314	324.5	65	130	155	19	90	11	55	40	22	24.5	139	199.5	6	141.5	90	12
	Ø28	30,40,50,60,80,100	330	337.5	90	140	175	23.5	125	11	65	45	28	31	139	210	8	170	110	15
	Ø32	100,120,160,200	349	357	130	170	208	28.5	170	13	70	55	32	35	139	226	10	198	130	18
0.75	Ø28	5,10,15,20,25	350.5	343.5	90	140	175	23.5	125	11	65	45	28	31	159	222	8	170	110	15
	Ø32	30,40,50,60,80,100	379.5	387	130	170	208	28.5	170	13	70	55	32	35	159	238.5	10	198	130	18
	Ø40	100,120,160,200	401.5	408.5	150	210	254	34	196	15	90	65	40	43	185	249	10	230	150	20
1.5	Ø32	5,10,15,20,25	420.5	441	130	170	208	28.5	170	13	70	55	32	35	185	250.5	10	198	130	18
	Ø40	30,40,50,60,80,100	457.5	478	150	210	254	34	196	15	90	65	40	43	185	260	10	230	150	20
	Ø50	100,120,160,200	485.5	506	160	230	290	40	210	18	100	75	50	53.5	185	288	14	265	170	25
2.2	Ø40	5,10,15,20,25	466.5	487	150	210	254	34	196	15	90	65	40	43	185	260	10	230	150	20
	Ø50	30,40,50,60,80,100	510.5	531	160	230	290	40	210	18	100	75	50	53.5	185	288	14	265	170	25

G3FM THREE-PHASE MOTOR REDUCER WITH FLANGE

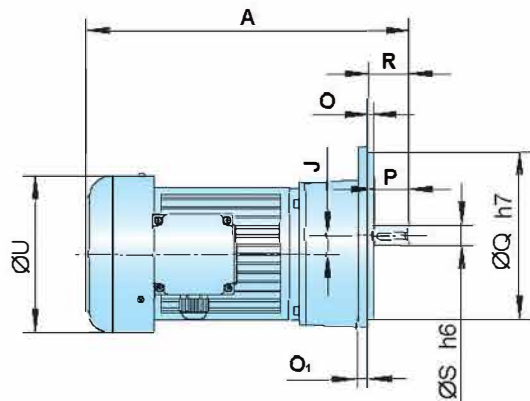
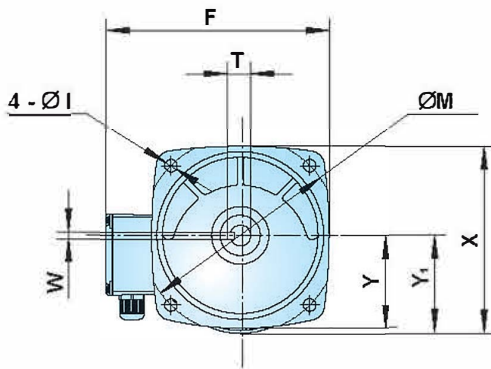
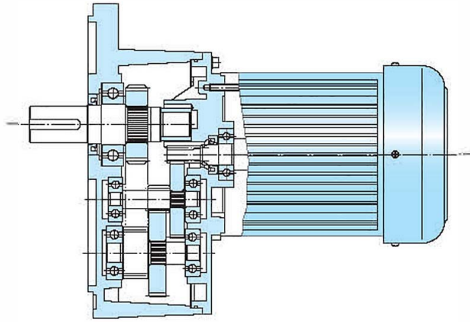

motor rotate speed 1400 r / min

power kW	output shaft	ratio	primary outline and dimension-mount																		
			A		F	I	J	M	O	O ₁	P	Q	R	S	T	U	W	X	Y	Y ₁	
			standard	brake																	
0.1	Ø18	5, 10, 15, 20, 25, 30, 40, 50	236	270	192.5	11	16.5	170	4	10	30	145	35	18	20.5	129	6	157	80	81	
	Ø22	60, 80, 100, 120, 160, 200	262	296	197.5	11	19	185	4	12	40	148	47	22	24.5	129	6	171.5	89.5	83.5	
0.2	Ø18	5, 10, 15, 20, 25	267	270	192.5	11	16.5	170	4	10	30	145	35	18	20.5	129	6	161	80	81	
	Ø22	30, 40, 50, 60, 80, 100	293	296	197.5	11	19	185	4	12	40	148	47	22	24.5	129	6	171.5	89.5	83.5	
	Ø28	100, 120, 160, 200	306	309.5	208.5	11	23.5	215	4	15	45	170	50	28	31	129	8	198.5	105.5	88	
0.4	Ø22	5, 10, 15, 20, 25	314	324.5	204	11	19	185	4	12	40	148	47	22	24.5	139	6	171.5	89.5	88.5	
	Ø28	30, 40, 50, 60, 80, 100	330	337.5	215	11	23.5	215	4	15	45	170	50	28	31	139	8	198.5	105.5	93	
	Ø32	100, 120, 160, 200	349	357	229.5	13	28.5	250	4	15	55	180	60	32	35	139	10	234	126	98	
0.75	Ø28	5, 10, 15, 20, 25	350.5	343.5	227.5	11	23.5	215	4	15	45	170	50	28	31	159	8	198.5	105.5	103	
	Ø32	30, 40, 50, 60, 80, 100	379.5	387	242	13	28.5	250	4	15	55	180	60	32	35	159	10	234	126	108	
	Ø40	100, 120, 160, 200	401.5	408.5	270	18	34	310	5	18	65	230	71	40	43	185	10	284	149	126.5	
1.5	Ø32	5, 10, 15, 20, 25	420.5	441	254	13	28.5	250	5	15	55	180	60	32	35	185	10	234	126	121	
	Ø40	30, 40, 50, 60, 80, 100	457.5	478	270	18	34	310	5	18	65	230	71	40	43	185	10	284	149	126.5	
	Ø50	100, 120, 160, 200	485.5	506	300	22	40	360	5	25	75	270	83	50	53.5	185	14	32.5	173.5	132.5	
2.2	Ø40	5, 10, 15, 20, 25	466.5	487	270	18	34	310	5	18	65	230	71	40	43	185	10	284	149	126.5	
	Ø50	30, 40, 50, 60, 80, 100	510.5	531	300	22	40	360	5	25	75	270	83	50	53.5	185	14	32.5	173.5	132.5	

G3LS IEC INPUT REDUCER WITH FOOT

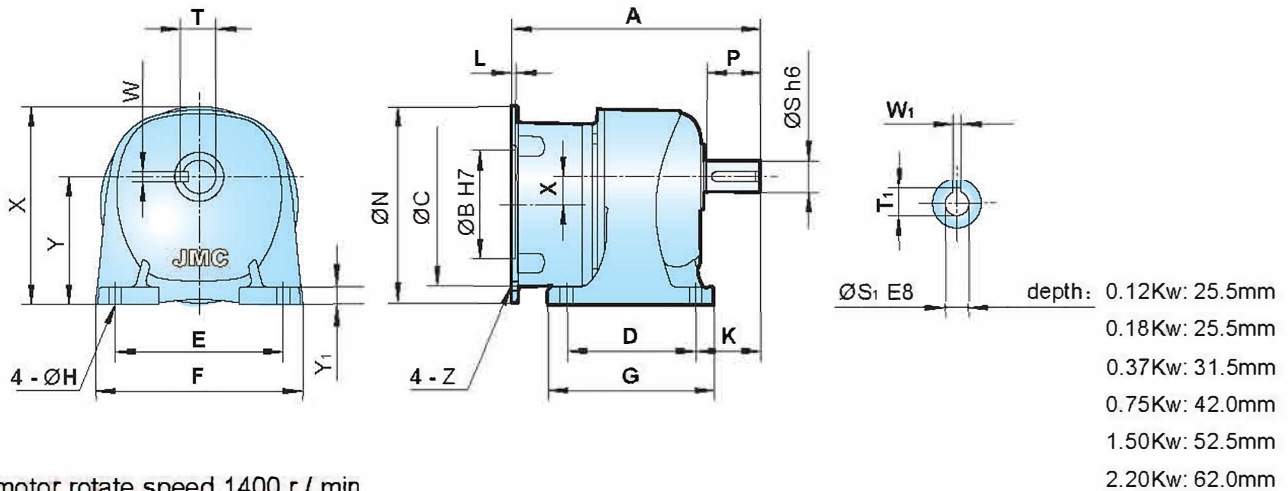
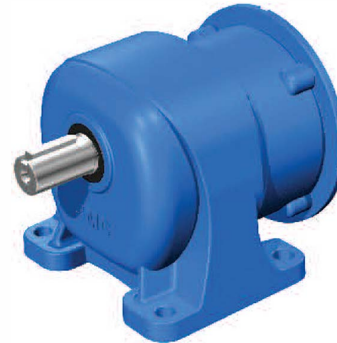
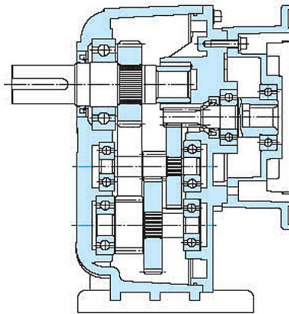

motor rotate speed 1400 r / min

power kW	output shaft	ratio	primary outline and dimension-mount																						
			A	B	C	D	E	F	G	H	J	K	L	N	P	S	S ₁	T	T ₁	W	W ₁	X	Y	Y ₁	Z
0.12	Ø18	5,10,15,20,25,30,40,50	147	95	115	40	110	135	65	9	16.5	45	4.5	140	30	18	11	20.5	12.8	6	4	138.5	85	10	M8
	Ø22	60,80,100,120,160,200	173	95	115	65	130	154	90	11	19	55	4.5	140	40	22	11	24.5	12.8	6	4	141	90	12	M8
0.18	Ø18	5,10,15,20,25	147	95	115	40	110	135	65	9	16.5	45	4.5	140	30	18	11	20.5	12.8	6	4	138.5	85	10	M8
	Ø22	30,40,50,60,80,100	173	95	115	65	130	154	90	11	19	55	4.5	140	40	22	11	24.5	12.8	6	4	141	90	12	M8
	Ø28	100,120,160,200	186.5	95	115	90	140	175	125	11	23.5	65	4.5	140	45	28	11	31	12.8	8	4	170	110	15	M8
0.37	Ø22	5,10,15,20,25	181.5	110	130	65	130	154	90	11	19	55	4.5	160	40	22	14	24.5	16.3	6	5	151	90	12	M8
	Ø28	30,40,50,60,80,100	198	110	130	90	140	175	125	11	23.5	65	4.5	160	45	28	14	31	16.3	8	5	170	110	15	M8
	Ø32	100,120,160,200	216.5	110	130	130	170	208	170	13	28.5	70	4.5	160	55	32	14	35	16.3	10	5	198	130	18	M8
0.75	Ø28	5,10,15,20,25	206.5	130	165	90	140	175	125	11	23.5	65	4.5	200	45	28	19	31	21.8	8	6	186.5	110	15	M10
	Ø32	30,40,50,60,80,100	235	130	165	130	170	208	170	13	28.5	70	4.5	200	55	32	19	35	21.8	10	6	201.5	130	18	M10
	Ø40	100,120,160,200	260.5	130	165	150	210	254	196	15	34	90	4.5	200	65	40	19	43	21.8	10	8	230	150	20	M10
1.5	Ø32	5,10,15,20,25	252	130	165	130	170	208	170	13	28.5	70	4.5	200	55	32	24	35	27.3	10	8	201.5	130	18	M10
	Ø40	30,40,50,60,80,100	293.5	130	165	150	210	254	196	15	34	90	4.5	200	65	40	24	43	27.3	10	8	230	150	20	M10
	Ø50	100,120,160,200	321.5	130	165	160	230	290	210	18	40	100	4.5	200	75	50	24	53.5	27.3	14	8	265	170	25	M10
2.2	Ø40	5,10,15,20,25	290	180	215	150	210	254	196	15	34	90	5.5	250	65	40	28	43	31.3	10	8	230	150	20	M12
	Ø50	30,40,50,60,80,100	334	180	215	160	230	290	210	18	40	100	5.5	250	75	50	28	53.5	31.3	14	8	265	170	25	M12

G3FS IEC INPUT REDUCER WITH FLANGE

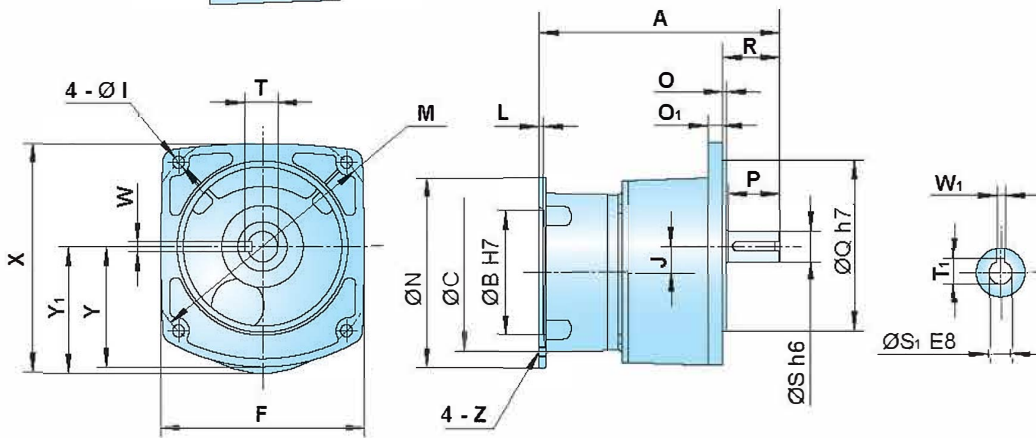
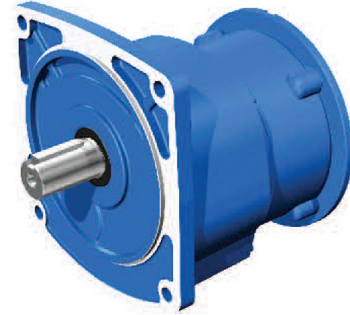
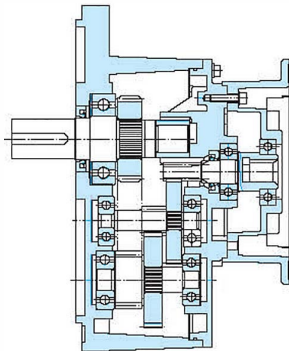

- depth: 0.12Kw: 25.5mm
 0.18Kw: 25.5mm
 0.37Kw: 31.5mm
 0.75Kw: 42.0mm
 1.50Kw: 52.5mm
 2.20Kw: 62.0mm

motor rotate speed 1400 r / min

power kW	output shaft	ratio	primary outline and dimension-mount																							
			A	B	C	F	I	J	L	M	N	O	O ₁	P	Q	R	S	S ₁	T	T ₁	W	W ₁	X	Y	Y ₁	Z
0.12	Ø18	5,10,15,20,25,30,40,50	147	95	115	154	11	16.5	4.5	170	140	4	10	30	145	35	18	11	20.5	12.8	6	4	163.5	80	86.5	M8
	Ø22	60,80,100,120,160,200	173	95	115	164	11	19	4.5	185	140	4	12	40	148	47	22	11	24.5	12.8	6	4	171.5	89.5	89	M8
0.18	Ø18	5,10,15,20,25	147	95	115	154	11	16.5	4.5	170	140	4	10	30	145	35	18	11	20.5	12.8	6	4	163.5	80	86.5	M8
	Ø22	30,40,50,60,80,100	173	95	115	164	11	19	4.5	185	140	4	12	40	148	47	22	11	24.5	12.8	6	4	171.5	89.5	89	M8
	Ø28	100,120,160,200	186.5	95	115	186	11	23.5	4.5	215	140	4	15	45	170	50	28	11	31	12.8	8	4	198.5	105.5	93.5	M8
0.37	Ø22	5,10,15,20,25	181.5	110	130	164	11	19	4.5	185	160	4	12	40	148	47	22	14	24.5	16.3	6	5	201	89.5	99	M8
	Ø28	30,40,50,60,80,100	198	110	130	186	11	23.5	4.5	215	160	4	15	45	170	50	28	14	31	16.3	8	5	198.5	105.5	103.5	M8
	Ø32	100,120,160,200	216.5	110	130	215	13	28.5	4.5	250	160	4	15	55	180	60	32	14	35	16.3	10	5	234	126	108.5	M8
0.75	Ø28	5,10,15,20,25	206.5	130	165	185	11	23.5	4.5	215	200	4	15	45	170	50	28	19	31	21.8	8	6	216.5	105.5	123.5	M10
	Ø32	30,40,50,60,80,100	235	130	165	215	13	28.5	4.5	250	200	4	15	55	180	60	32	19	35	21.8	10	6	236.5	126	128.5	M10
	Ø40	100,120,160,200	260.5	130	165	270	18	34	4.5	310	200	5	18	65	230	71	40	19	43	21.8	10	6	284	149	134	M10
1.5	Ø32	5,10,15,20,25	252	130	165	215	13	28.5	4.5	250	200	4	15	55	180	60	32	24	35	27.3	10	8	236.5	126	128.5	M10
	Ø40	30,40,50,60,80,100	293.5	130	165	270	18	34	4.5	310	200	5	18	65	230	71	40	24	43	27.3	10	8	284	149	134	M10
	Ø50	100,120,160,200	321.5	130	165	300	22	40	4.5	360	200	5	25	75	270	83	50	24	53.5	27.3	14	8	323.5	173.5	140	M10
2.2	Ø40	5,10,15,20,25	290	180	215	270	18	34	5	310	250	5	18	65	230	71	40	28	43	31.3	10	8	284	149	134	M12
	Ø50	30,40,50,60,80,100	334	180	215	300	22	40	5	360	250	5	25	75	270	83	50	28	53.5	31.3	14	8	323.5	173.5	140	M12

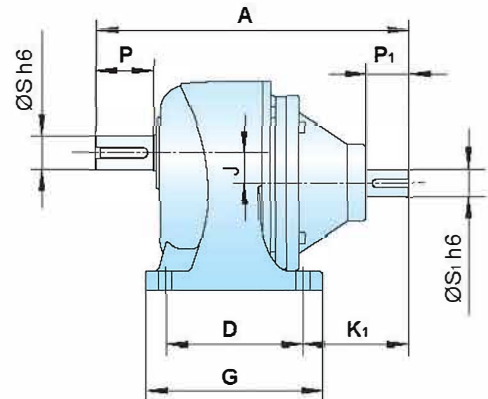
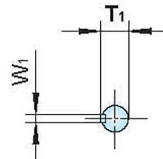
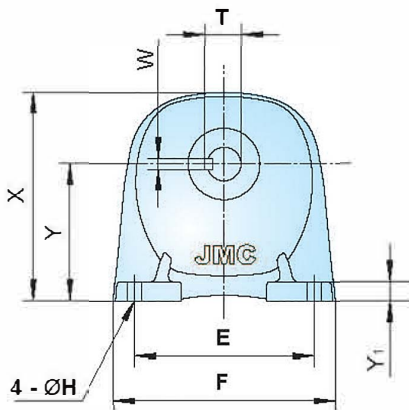
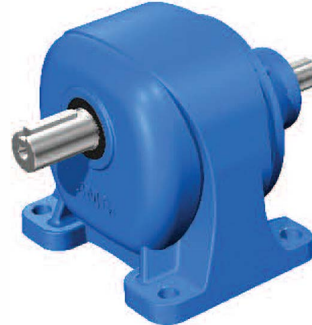
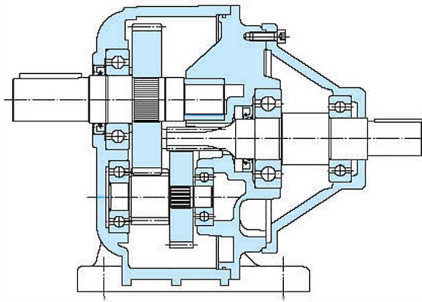
G3L SHAFT INPUT REDUCER WITH FOOT

motor rotate speed 1400 r / min

power kW	output shaft	ratio	primary outline and dimension-mount																		
			A	D	E	F	G	H	J	K ₁	P	P ₁	S	S ₁	T	T ₁	W	W ₁	X	Y	Y ₁
0.1	Ø18	5,10,15,20,25,30,40,50	181.5	40	110	135	65	9	16.5	96.5	30	25	18	12	20.5	13.5	6	4	131	85	10
	Ø22	60,80,100,120,160,200	207.5	65	130	154	90	11	19	87.5	40	25	22	12	24.5	13.5	6	4	139.5	90	12
0.2	Ø18	5,10,15,20,25	181.5	40	110	135	65	9	16.5	96.5	30	25	18	12	20.5	13.5	6	4	131	85	10
	Ø22	30,40,50,60,80,100	207.5	65	130	154	90	11	19	87.5	40	25	22	12	24.5	13.5	6	4	139.5	90	12
0.4	Ø28	100,120,160,200	220.5	90	140	175	125	11	23.5	65.5	45	25	28	12	31	13.5	8	4	170	110	15
	Ø22	5,10,15,20,25	219	65	130	154	90	11	19	99	40	30	22	15	24.5	17	6	5	139.5	90	12
	Ø28	30,40,50,60,80,100	235	90	140	175	125	11	23.5	80	45	30	28	15	31	17	8	5	170	110	15
0.75	Ø32	100,120,160,200	254	130	170	208	170	13	28.5	54	55	30	32	15	35	17	10	5	198	130	18
	Ø28	5,10,15,20,25	244.5	90	140	175	125	11	23.5	89.5	45	35	28	20	31	22.5	8	6	170	110	15
	Ø32	30,40,50,60,80,100	273.5	130	170	208	170	13	28.5	73.5	55	35	32	20	35	22.5	10	6	198	130	18
1.5	Ø40	100,120,160,200	295.5	150	210	254	196	15	34	55.5	65	35	40	20	43	22.5	10	6	230	150	20
	Ø32	5,10,15,20,25	297	130	170	208	170	13	28.5	97	55	40	32	25	35	28	10	8	198	130	18
	Ø40	30,40,50,60,80,100	334	150	210	254	196	15	34	94	65	40	40	25	43	28	10	8	230	150	20
2.2	Ø50	100,120,160,200	362	160	230	290	210	18	40	102	75	40	50	25	53.5	28	14	8	265	170	25
	Ø40	5,10,15,20,25	330	150	210	254	196	15	34	90	65	45	40	30	43	33	10	8	230	150	20
2.2	Ø50	30,40,50,60,80,100	374	160	230	290	210	18	40	114	75	45	50	30	53.5	33	14	8	265	170	25

G3F SHAFT INPUT REDUCER WITH FLANGF

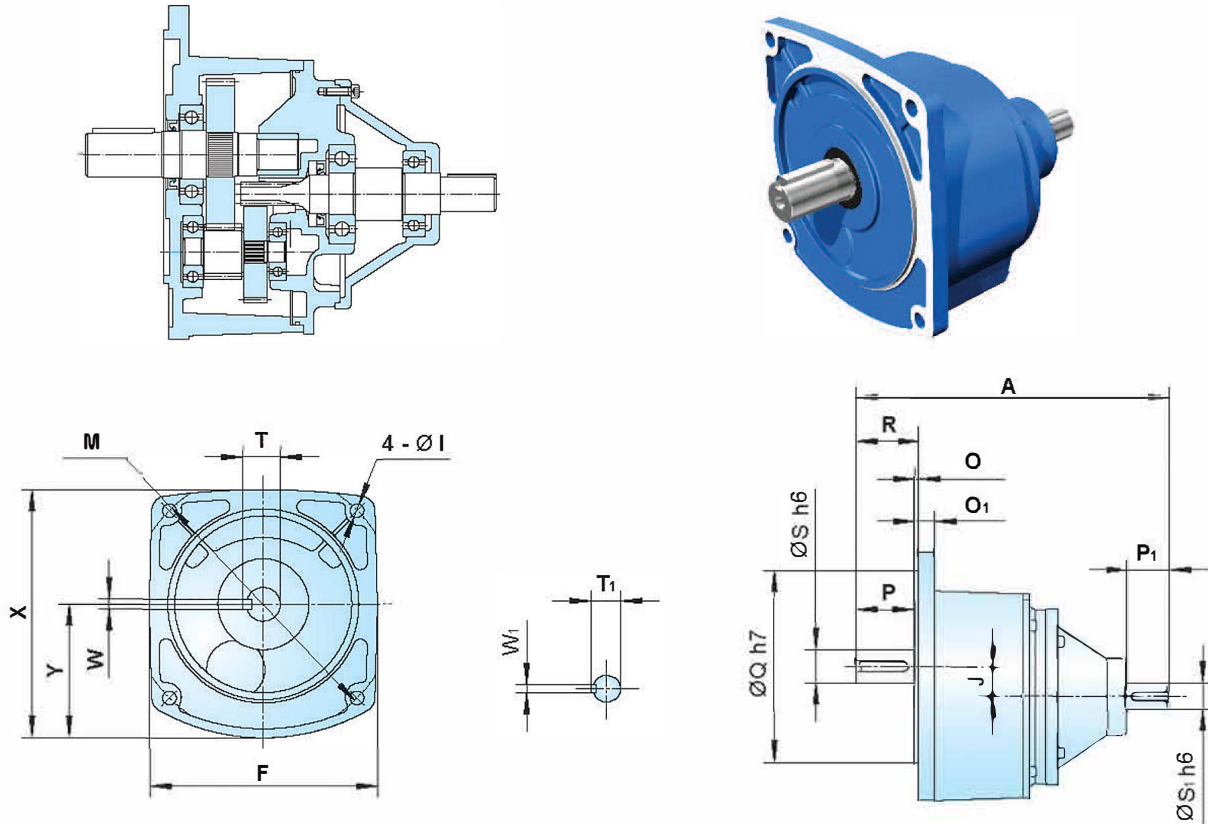

motor rotate speed 1400 r / min

power kW	output shaft	ratio	primary outline and dimension-mount																		
			A	F	I	J	M	O	O ₁	P	P ₁	Q	R	S	S ₁	T	T ₁	W	W ₁	X	Y
0.1	Ø18	5,10,15,20 25,30,40,50	181.5	154	11	16.5	170	4	10	30	25	145	35	18	12	20.5	13.5	6	4	157	80
	Ø22	60,80,100,120,160,200	207.5	164	11	19	185	4	12	40	25	148	47	22	12	24.5	13.5	6	4	171.5	89.5
0.2	Ø18	5,10,15,20,25	181.5	154	11	16.5	170	4	10	30	25	145	35	18	12	20.5	13.5	6	4	157	80
	Ø22	30,40,50,60 80,100	207.5	164	11	19	185	4	12	40	25	148	47	22	12	24.5	13.5	6	4	171.5	89.5
	Ø28	100,120,160,200	220.5	186	11	23.5	215	4	15	45	25	170	50	28	12	31	13.5	8	4	198.5	105.5
0.4	Ø22	5,10,15,20,25	219	164	11	19	185	4	12	40	30	148	47	22	15	24.5	17	6	5	171.5	89.5
	Ø28	30,40,50,60 80,100	235	186	11	23.5	215	4	15	45	30	170	50	28	15	31	17	8	5	198.5	105.5
	Ø32	100,120,160,200	254	215	13	28.5	250	4	15	55	30	180	60	32	15	35	17	10	5	234	126
0.75	Ø28	5,10,15,20,25	244.5	185	11	23.5	215	4	15	45	35	170	50	28	20	31	22.5	8	6	198.5	105.5
	Ø32	30,40,50,60 80,100	273.5	215	13	28.5	250	4	15	55	35	180	60	32	20	35	22.5	10	6	234	126
	Ø40	100,120,160,200	295.5	270	18	34	310	5	18	65	35	230	71	40	20	43	22.5	10	6	284	149
1.5	Ø32	5,10,15,20,25	297	215	13	28.5	250	4	15	55	40	180	60	32	25	35	28	10	8	234	126
	Ø40	30,40,50,60 80,100	334	270	18	34	310	5	18	65	40	230	71	40	25	43	28	10	8	284	149
	Ø50	100,120,160,200	362	300	22	40	360	5	25	75	40	270	83	50	25	53.5	28	14	8	323.5	173.5
2.2	Ø40	5,10,15,20,25	330	270	18	34	310	5	18	65	45	230	71	40	30	43	33	10	8	284	149
	Ø50	30,40,50,60 80,100	374	300	22	40	360	5	25	75	45	270	83	50	30	53.5	33	14	8	323.5	173.5

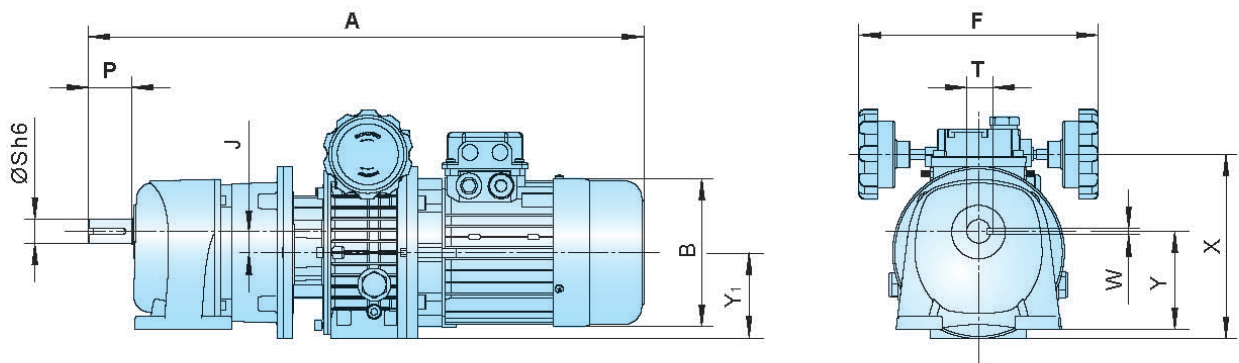
UDL - G3LS COMBINATION OF SPEED VARIATOR AND IEC INPUT REDUCER WITH FOOT

motor rotate speed 1400 r / min

power kW	output shaft	G3LS i_1	UDL i_2	primary outline and dimension-mount										
				A	B	F	J	P	S	T	W	X	Y	Y ₁
0.18	Ø18	5,10,15,20,25	1.6~8.2	459.5	120	220	16.5	30	18	20.5	6	148	85	70
	Ø22	30,40,50,60 80,100	1.4~7.0	485.5	120	220	19	40	22	24.5	6	148	90	70
	Ø28	100,120,160,200	1.4~7.0	499	120	220	23.5	45	28	31	8	148	110	70
0.37	Ø22	5,10,15,20,25	1.4~7.0	494	141	220	19	40	22	24.5	6	170	90	80
	Ø28	30,40,50,60 80,100	1.4~7.0	510.5	141	220	23.5	45	28	31	8	170	110	80
	Ø32	100,120,160,200	1.4~7.0	583.5	141	220	28.5	55	32	35	10	170	130	80
0.75	Ø28	5,10,15,20,25	1.4~7.0	649.5	160	240	23.5	45	28	31	8	207	110	100
	Ø32	30,40,50,60 80,100	1.4~7.0	678.5	160	240	28.5	55	32	35	10	207	130	100

UDL - G3FS COMBINATION OF SPEED VARIATOR AND IEC INPUT REDUCER WITH FLANGE

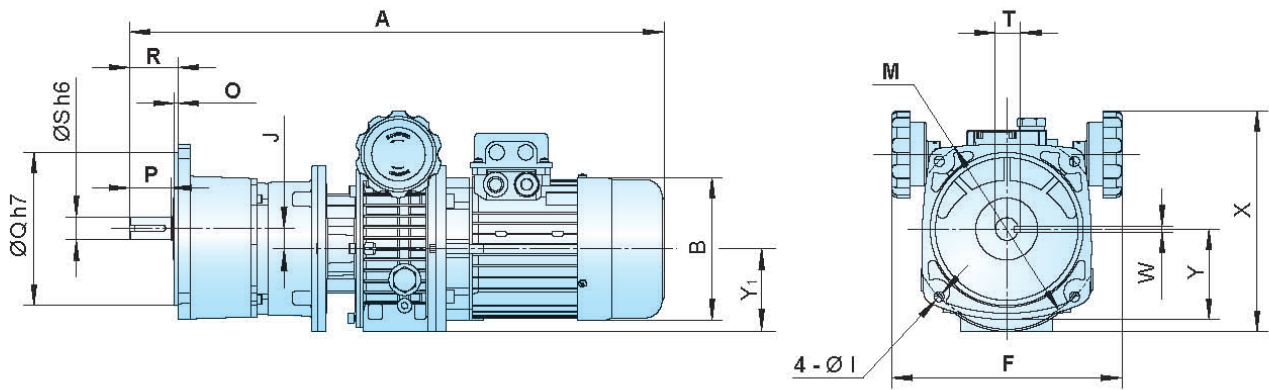

motor rotate speed 1400 r / min

power kW	output shaft	G3FS i_1	UDL i_2	primary outline and dimension-mount														
				A	B	F	I	J	O	P	Q	R	S	T	W	X	Y	Y ₁
0.18	Ø 18	5,10,15,20,25	1.6~8.2	459.5	120	220	11	16.5	4	30	145	35	18	20.5	6	148	80	70
	Ø 22	30,40,50,60 80,100	1.4~7.0	485.5	120	220	11	19	4	40	148	47	22	24.5	6	148	89.5	70
	Ø 28	100,120,160,200	1.4~7.0	499	120	220	11	23.5	4	45	170	50	28	31	8	148	105.5	70
0.37	Ø 22	5,10,15,20,25	1.4~7.0	494	141	220	11	19	4	40	148	47	22	24.5	6	170	89.5	80
	Ø 28	30,40,50,60 80,100	1.4~7.0	510.5	141	220	11	23.5	4	45	170	50	28	31	8	170	105.5	80
	Ø 32	100,120,160,200	1.4~7.0	583.5	141	220	13	28.5	4	55	180	60	32	35	10	170	126	80
0.75	Ø 28	5,10,15,20,25	1.4~7.0	649.5	160	240	11	23.5	4	45	170	50	28	31	8	207	105.5	100
	Ø 32	30,40,50,60 80,100	1.4~7.0	678.5	160	240	13	28.5	4	55	180	60	32	35	10	207	126	100

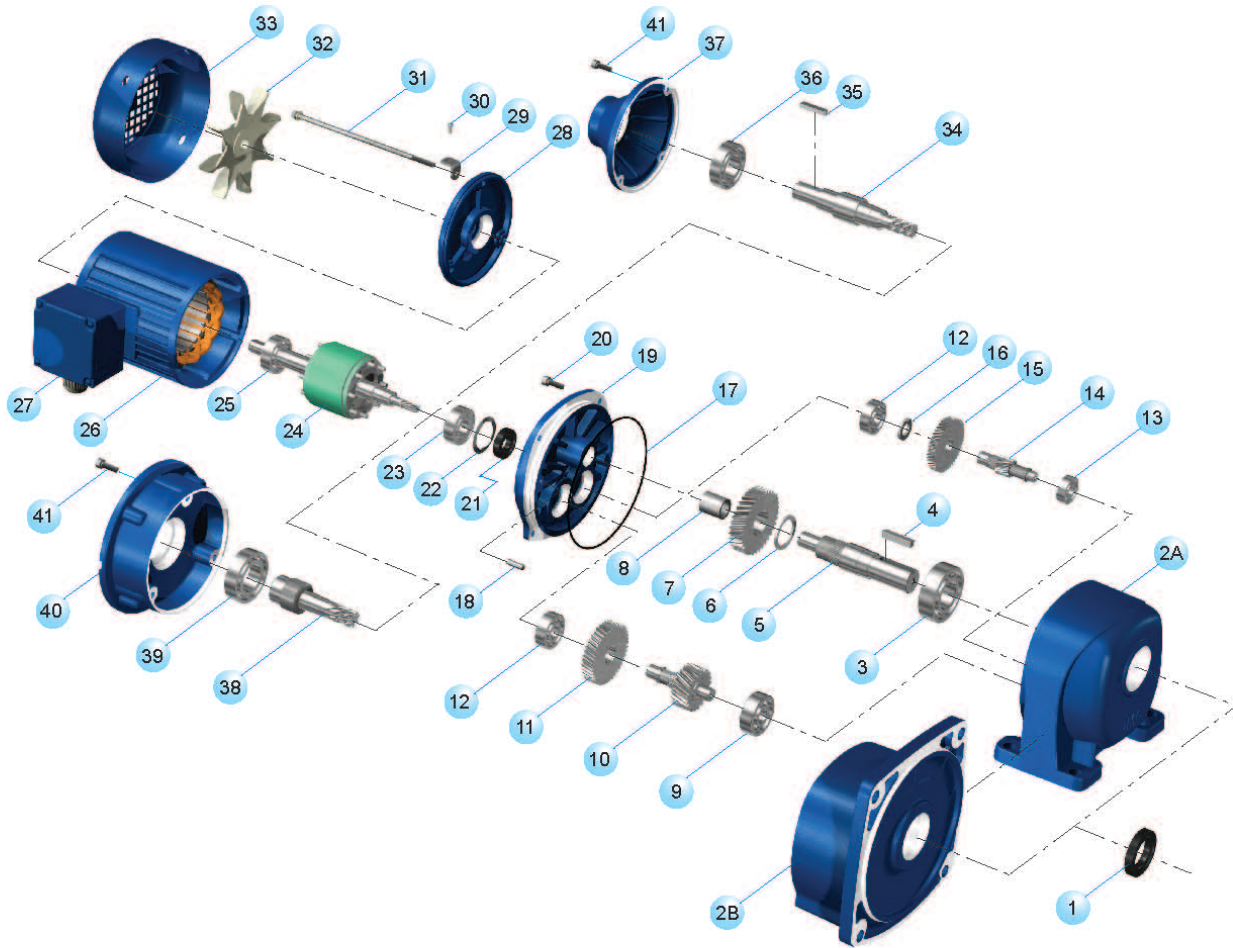
2 STAGES /3 STAGE EXPLODED VIEW

NO.	Description	NO.	Description	NO.	Description
1	oil seal-output shaft	14	pinion-2 nd stage	28	rear cover-motor
2A	foot housing	15	gear-1 st stage	29	bracket
2B	flange housing	16	spacer	30	screw-fan cover
3	bearing-output shaft	17	O-RING	31	long bolt-motor
4	key-output shaft	18	pin	32	cooling fan
5	output shaft	19	motor flange	33	fan cover-motor
6	spacer	20	inner hexangular screw	34	input shaft gear shaft
7	gear-3 rd stage	21	oil seal-motor shaft	35	key-input shaft
8	oiliness bearing	22	spring washer	36	bearing-input shaft gear shaft
9	bearing-3 rd stage pinion	23	bearing-motor shaft	37	input cover
10	pinion-3 rd stage	24	rotor	38	input hole gear shaft
11	bearing-2 nd stage	25	bearing-motor shaft	39	bearing-input hole gear shaft
12	bearing-motor flange	26	motor stator	40	flange-input
13	bearing-2 nd stage pinion	27	wire box	41	Inner hexagon screw

CORRECT THE MALFUNCTION

defective reason		analysis	solution method
noise	knocking	gear surface damaged	contact manufacturer,replace gear set
	continual cacophony	bearing damaged	replace the damaged bearing
	periodical cacophony	particle on the gear surface	check gear surface
	neigh	lack of lubricant	fill with lubricant
	intermittent cacophony	dirty lubricant	replace the new lubricant
shake	fixed foundation shake	deflective mount on the surface	re-adjust fixed pedestal
	output shaft shake	bearing damaged	replace the damaged bearing
	inner gear parts shake	gear damaged	replace the damaged gear
	housing shake	defective gear assembly	re-adjust the gear set
leakage	oil seal leakage	oil seal vulcanize	replace the damaged oil seal
	housing leakage	housing with the sand hole	replace housing with the sand hole
	combined surface leakage	o-ring damaged	replace the damaged o-ring
over-heating	oil seal damaged	over-tighten oil seal	replace over-tighten oil seal
	over-heat housing	over-load	re-calculate load
	lack of lubricant	low lubricant	fill with lubricant
	over-heat motor	1.the temperature of environment is too high.2.airiness is bad.3.pressure is too high or too low.	1.take measure to reduce the temperature 2.clean out the wind passage, and check the motor if cooling fan has been damaged 3.adjust electrical source pressure
the motor can't work	electrical source haven't been switched on	check if the switch is contacted well, if the fuse wire is broken or the motor down.lead is broken.	
the rotate speed of the output shaft is too low	wrong control connection outside over loading wrong ratio electrical source pressure too low over-load	correct it on the right connection reduce the load check the rotation ratio of the cooling fan and output shaft by hand adjust electrical source pressure reduce load	
motor circumrotate,output shaft don't circumrotate	inner gear set damaged	please contact the manufacture to replace the gear set	