



# PCM 100 SERIES CENTRIFUGAL PUMP

## USER

Single impeller centrifugal pumps, extremely silent suitable for household, civil and industrial applications, with a very flat curve to guarantee constant pressure even when the delivery.

## MOTOR

2 pole electric induction motor.  
IP 44, Class B insulation.  
Continuous Duty S1

## CONSTRUCTION FEATURES

Cast iron pump casing and motor bracket.  
Brass impeller, carbon / ceramic mechanical seal.  
Welded Stainless steel shaft, C & U Ball Bearings.

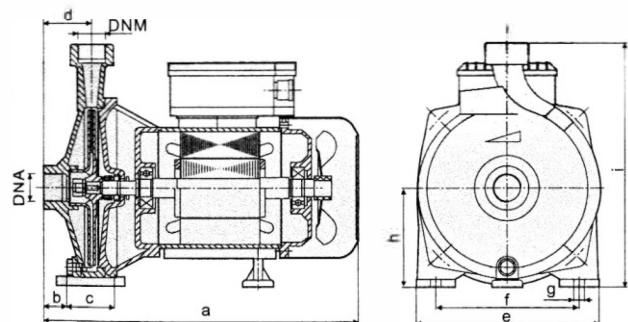

## Performance Specifications

Model		P2 nom.	Ampere		Q = Capacity													
Single Phase 240V 50HZ	Three Phase 415V 50HZ		1~	3~	Q m <sup>3</sup> /h	0	1.2	2.4	3.6	4.8	5.4	6	6.6	9	11	18	24	30
		HP/kW	1x240V	3x415V	U/min	0	20	40	60	80	90	100	110	150	180	300	400	500
					Total Head In Meters													
PCM 100	PCMT 100	1.0 / 0.75	5.2	1.6		32	30	26.5	23	18	15	12	8	-	-	-	-	-

## Overall & Installation Dimensions

Model	DIMENSIONS (mm)														PACKAGE DIMENSION & G. W.						
	DNA		DNM		a	b	c	d	e	f	g	h	i	j	k	l	m	A	B	H	kg
	Inch	Mm	Inch	Mm																	
PCM 100	1"	25	1"	25	305	-	-	44	190	160	10	100	242	-	-	-	-	340	210	260	13.8

