



- 01 -      - 02 -      - 03 -      - 04 -      - 05 -      - 06 -      - 07 -      - 08 -

## Pumps

- Peripheral Pump
- Jet Pump
- Centrifugal Pump
- Submersible Pump
- Submersible Sewage Pump
- Flexible Shaft Pump
- Domestic Lifting Station
- Pool Pump
- Garden Submersible Pump
- Garden Jet Pump
- Pressure Booster System
- Fountain Pump
- Standard Centrifugal Pump
- Submersible Borehole Pump

LEO GROUP PUMP(ZHEJIANG) CO.,LTD. (Stock code: 002131)

No.1, 3rd Street, East Industry Center, Wenling, Zhejiang, China, 317511  
 Tel: +86-576-8998 6360 Fax: +86-576-8998 9898 E-mail: export@leogroup.cn www.leogroup.cn

[www.leogroup.cn](http://www.leogroup.cn)

LEO GROUP PUMP(ZHEJIANG) CO.,LTD.



[www.leogroup.cn](http://www.leogroup.cn)



## HISTORY

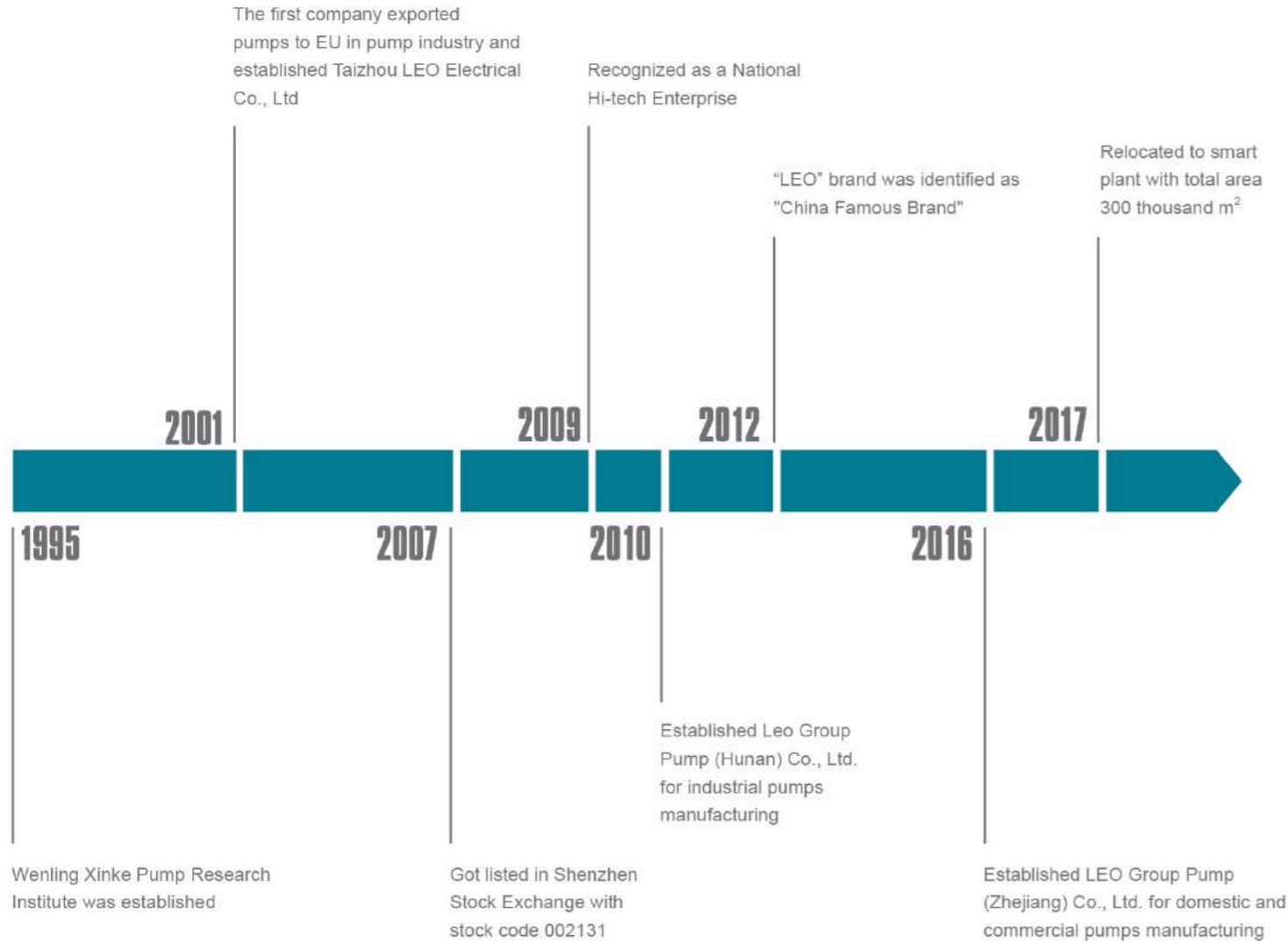

## TO KNOW LEO

LEO Group (got listed in Shenzhen Stock Exchange with stock code 002131) is a national high-tech enterprise engaged in R&D, design, manufacture, sales and service of all series pumps and systems. LEO is the first listed company in Chinese pump industry, one of the drafters of pump industry standard and the vice president of drainage and irrigation machinery branch of China Agricultural machinery industry association as well. "LEO" has been identified as "China Famous Brand" by the State Administration of Industry and Commerce. It is mentionable that LEO has the only state-authorized technical center in pump industry.

We have set up many production and sales subsidiaries in key regional markets such as America, Hungary, Belgium, Thailand, Indonesia, United Arab Emirates and Bangladesh and authorized exclusive distribution agency in over 100 countries.

Our products have been sold to over 120 countries and regions, such as Europe, North America, Central & South America, Southeast Asia, Middle East, Africa, Oceania, etc., which play a crucial role in water conservancy, water resources, electric power construction, petrochemical industry, mining, metallurgy, fire-fighting, HVAC (Heating, Ventilation and Air Conditioning), agricultural irrigation, civil water supply and drainage, etc.

LEO has currently two industrial groups respectively for industrial and civilian applications. With four manufacturing bases in Wengling of Zhejiang, Xiangtan of Hunan, Wuxi of Jiangsu and Dalian of Liaoning, LEO possesses a solid foundation to become a world-class pump and system solution provider rapidly.

With over 70 years' professional technology, LEO will continue her consistent creativity and development ability in each pump for human's health.





## NUMEROUS MEMBERS, ONE FAMILY

Based on market segment, LEO's pump business is divided into 5 fields, namely water conservancy & water resources, power station, petrochemical industry, mining & metallurgical industry and civilian applications. For each field there's a professional manufacturing base with relevant professional sales teams. Three subsidiary companies, Wuxi LEO Xi Pump, LEO Group Pump (Hunan) and Dalian LEO Pump are all well-known industrial pump manufacturers in their own fields. With over 70 years' industrial pump manufacturing experience and extraordinary comprehensive strength, LEO has become a leading company among all industrial pump manufacturers in China.



### Pump Manufacturing Base for Domestic and Commercial Applications (Wenling City, Zhejiang Province)

LEO Group Pump (Zhejiang) Co., Ltd, a wholly-owned subsidiary of LEO Group Co., Ltd, is the core base for R&D, manufacturing, sales and service of domestic and commercial pumps for family water supply, pipeline boosting, garden and field irrigation, HVAC, etc.

The leading products include peripheral pump, jet pump, centrifugal pump, garden submersible pump, fountain pump, pool pump, doestic lifting station, gasoline engine pump, diesel engine pump, submersible pump, submersible borehole pump, submersible sewage pump, stainless steel vertical multistage pump, etc.

The product range covers 15 series with over 2,000 specifications, which are well sold in more than 120 countries and regions. The base has established steady cooperative relationships with world-class pump manufacturers, importers, dealers and hypermarkets.



### Pump Manufacturing Base for General Industrial Pumps (Xiangtan City, Hunan Province)

Established in 2010, LEO Group Pump (Hunan) Co., Ltd. is a wholly-owned subsidiary by LEO Group Co., Ltd. Located in Jiuhua Economic Development Zone of Xiangtan City, Hunan Province. Covers an area of 85,000m<sup>2</sup> and construction area is about 92,635 m<sup>2</sup> with total investment of approximately 74 million dollars.

It is the most important R&D, manufacturing and testing center of LEO Group. The leading products include large mixed flow and axial flow pump (vertical, horizontal, oblique, tubular, submersible etc.), double-suction centrifugal pump, multistage centrifugal pump, slurry pump, desulphurization pump and submersible centrifugal pump. Products are mainly used in mine, metallurgy, coal washing, FGD, municipal water etc.



### Pump Manufacturing Base for Water Conservancy & Water Resources (Wuxi City, Jiangsu Province)

Formerly known as Wuxi Xi Pump Manufacturing Co., Ltd., a well-known manufacturer of water conservancy, is specialized in large and medium-sized pumps production for urban water supply and drainage, farmland irrigation, water conservancy projects and large water diversion project. The main products cover 32 series with nearly 1000 specifications. Products exported to more than 20 countries in Asia, Latin-America, Europe and Oceania.

As a main supplier, the base provides large pumps for South-to-North Water Diversion Project—a national key project. There are over 140 technicians, including 1 professor level senior engineer, 16 senior engineers, and 39 engineers.



### Pump Manufacturing Base for Petrochemical Industry (Dalian City, Liaoning Province)

It is the pump manufacturing base for petrochemical industry, combined with Dalian LEO Huaneng Pump Co., Ltd and LEO (Dalian) Industrial Pump Technology Center Co., Ltd.

Formerly known as Dalian Huaneng Corrosion-Resistant Pump Works, the base is specialized in production of petrochemical pumps for crude oil transportation, crude oil refinery, heavy chemical industry, coal chemical industry and fine chemistry, etc. The base focuses on design and manufacture of 30 series (OH, BB, VS, etc.) of petrochemical pumps with over 3000 specifications, which are in accordance with API and ISO standard.

LEO (Dalian) Industrial Pump Technology Center Co., Ltd. is one of the research branch of national level technology center for petrochemical pumps, specializes in R&D, design of pumps of petro chemistry, coal chemical industry, long-distance transport pipes, energy resources, fine chemicals industry, etc. Design and develop software and large laboratories, explore liquid transport schemes under severe conditions and solve the difficult projects of ultralow temperature, high temperature, high pressure, low cavitation, highly corrosive, energy recovery, etc.



# CONTENTS



• Peripheral Pump

P 01 - 12



• Self-Priming Peripheral Pump

P 13 - 24



• Jet Pump

P 25 - 30



• Jet Pump for Deep Wells

P 31 - 34



• Centrifugal Pump

P 35 - 48



• Multistage Centrifugal Pump

P 49 - 52



• Self-Priming Centrifugal Pump

P 53 - 54



• Stainless Steel Multistage Centrifugal Pump

P 55 - 60



• Stainless Steel Centrifugal Pump

P 61 - 64



• Submersible Pump

P 65 - 68



• Stainless Steel Submersible Pump

P 69 - 76

# CONTENTS



• Stainless Steel Submersible Sewage Pump

P 77 - 92



• Flexible Shaft Pump

P 93 - 94



• Domestic Lifting Station

P 95 - 96



• Pool Pump

P 97 - 100



• Garden Submersible Pump

P 101 - 116



• Garden Jet Pump

P 117 - 120



• Pressure Booster System

P 121 - 124



• Fountain Pump

P 125 - 126



• Standard Centrifugal Pump

P 127 - 152



• Accessories

P 153 - 157





### Application

- Can be used to transfer clean water or other liquids similar to water in physical and chemical properties
- Suitable for small living water supply, automatic water sprinkler system, small air conditioner system or supporting equipment etc.

### Pump

- Special anti-rust treatment for cast iron pump body
- Max. fluid temperature: +40°C
- Max. immersion depth: 5 m
- Liquid PH value: 6.5 – 8.5
- Maximum sand content: 0.1%
- Maximum solid diameter: 0.2 mm

### Motor

- Motor with copper winding
- Insulation class: F
- Protection class: IPX8

### Identification Codes

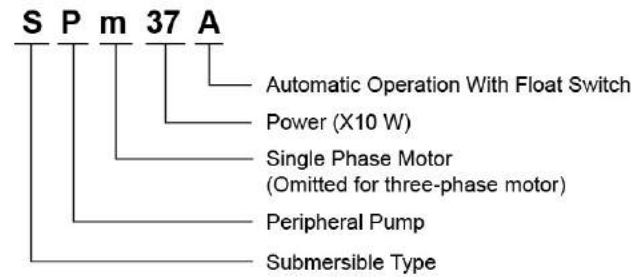

### Technical Data

MODEL	POWER		Q (m <sup>3</sup> /h)	0	0.5	1	1.5	2.0
	kW	HP						
SPm37A	0.37	0.5	<b>H(m)</b>	41.4	30.6	20.4	9.8	-

### Hydraulic Performance Curves

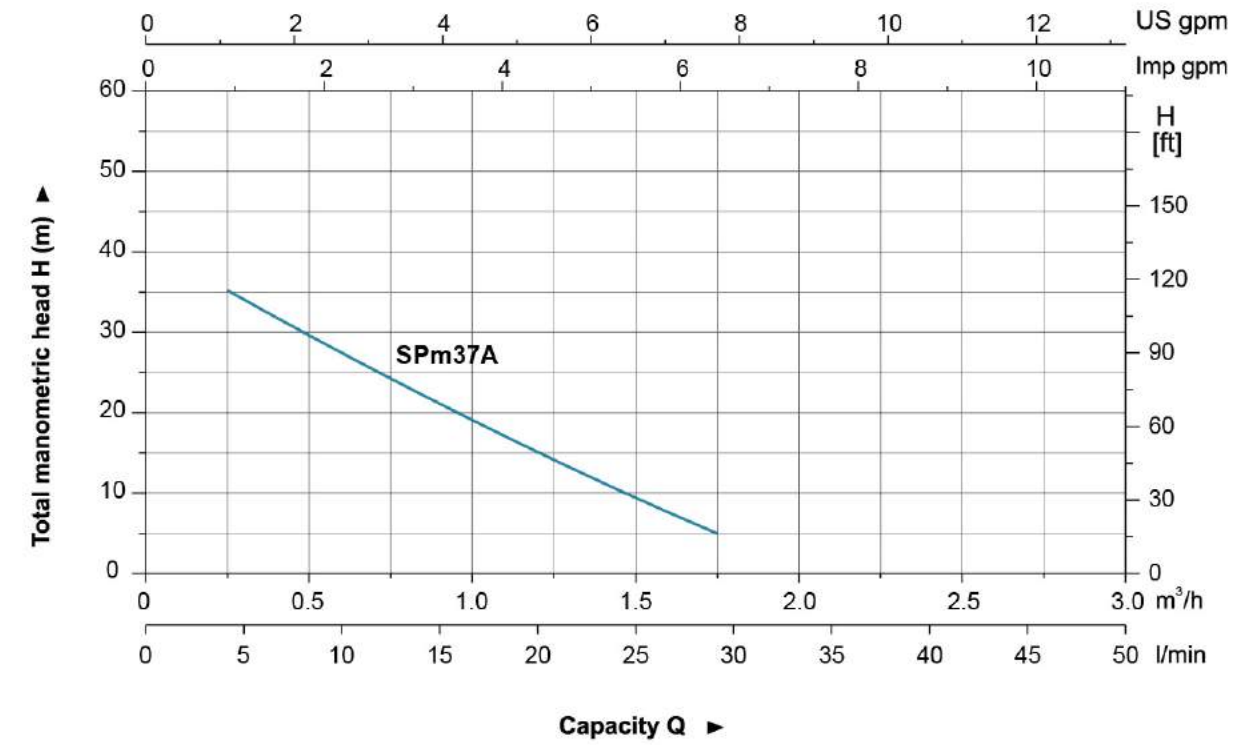

### Materials Table

No.	Part	Material
1	Casing cover	HT200
2	Impeller	Brass
3	Mechanical seal	Carbon/Ceramic
4	Pump body	HT200
5	Lower bearing seat	ZL 102
6	Oil seal	
7	Rotor	
8	Top cover	HT200
9	Capacitor	
10	O-ring	NBR
11	Upper bearing seat	HT200
12	Stator	
13	Screw	

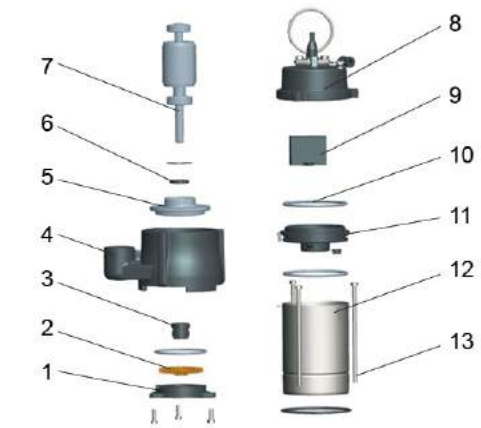

### Package Information

Model	GW (Kgs)	L (mm)	W (mm)	H (mm)	Quantity (PCS/20 TEU)
SPm37A	7.56	184	135	300	2439

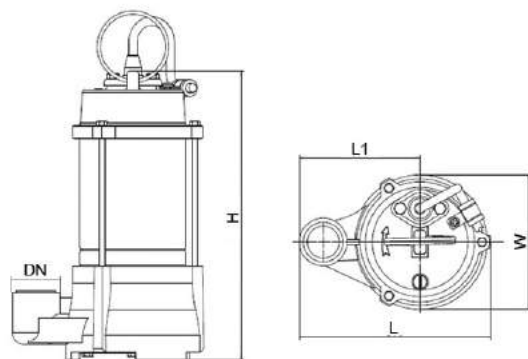

### Dimension

MODEL	DN	L (mm)	L1 (mm)	H (mm)	W (mm)
SPm37A	1"	170	106	244	118





### Application

- Can be used to transfer clean water or other liquids similar to water in physical and chemical properties
- Suitable for small living water supply, automatic water sprinkler system, small air conditioner system or supporting equipment etc.

### Pump

- Special anti-rust treatment for cast iron pump body and support
- Brass impeller
- AISI 304 shaft
- Max. liquid temperature: +60°C
- Max. suction: +8 m

### Motor

- C&U bearing
- Motor with copper winding
- Built-in thermal protector for single phase motor
- Insulation class: F
- Protection class: IPX4
- Max. ambient temperature: +40°C

### Identification Codes

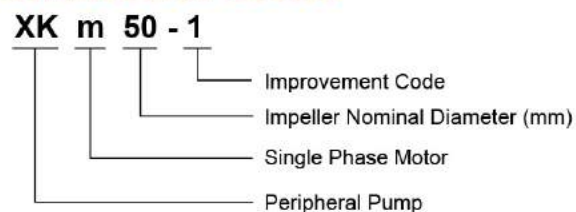

### Technical Data

MODEL	POWER		Q (m³/h)	0	0.3	0.6	0.9	1.2	1.5
	kW	HP							
XKm50-1	0.11	0.15	<b>H(m)</b>	23	19	15	11	7	3

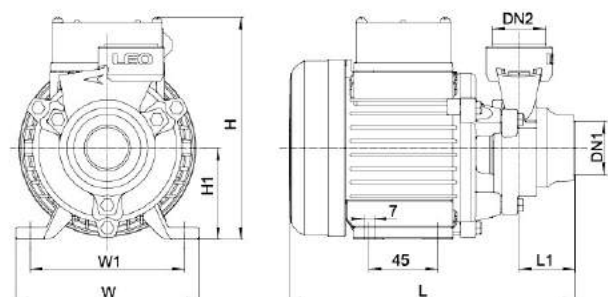

### Dimension

MODEL	DN1	DN2	L (mm)	L1 (mm)	H (mm)	H1 (mm)	W (mm)	W1 (mm)
XKm50-1	1"	1"	186.5	36	146	60	120	100

### Hydraulic Performance Curves

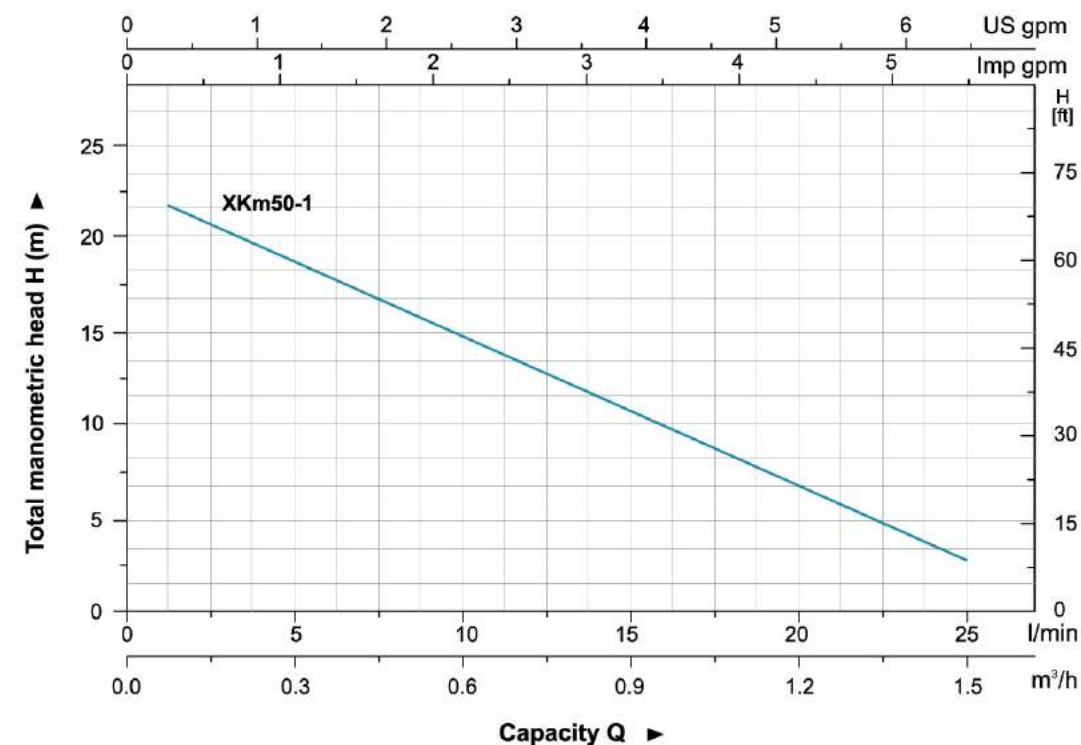

### Materials Table

No.	Part	Material
1	Pump body	HT 200
2	Impeller	Brass
3	Mechanical seal	Carbon/Ceramic
4	O-ring	NBR
5	Support	HT 200
6	Bearing	
7	Rotor	
8	Fan cover	PP
9	Fan	PP
10	Terminal box	PC/ABS
11	Capacitor	
12	Stator	
13	Filling plug	HPb59-1

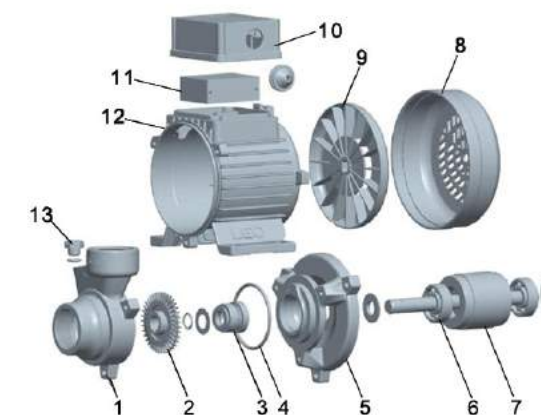

### Package Information

Model	GW (Kgs)	L (mm)	W (mm)	H (mm)	Quantity (PCS/20' TEU)
XKm50-1	3.6	200	140	160	4680







### Application

- Can be used to transfer clean water or other liquids similar to water in physical and chemical properties
- Suitable for small living water supply, automatic water sprinkler system, small air conditioner system or supporting equipment etc.

### Pump

- Special anti-rust treatment for cast iron pump body and support
- Anti-block system for impeller
- Brass impeller
- AISI 304 shaft
- Max. liquid temperature: +60°C
- Max. suction: +8 m

### Motor

- C&U bearing
- Motor with copper winding
- Built-in thermal protector for single phase motor
- Insulation class: F
- Protection class: IPX4
- Max. ambient temperature: +40°C
- IE 2 motor (AP110, AP150)

### Identification Codes

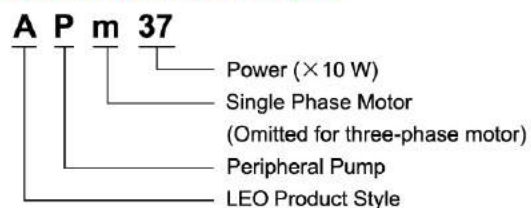

### Technical Data

MODEL		POWER		Q (m³/h)																
Single Phase	Three Phase	kW	HP	0	0.3	0.6	0.9	1.2	1.5	1.8	2.1	2.4	3.0	3.6	4.2	4.8	5.4			
				Q (l/min)																
				0	5	10	15	20	25	30	35	40	50	60	70	80	90			
APm30	—	0.3	0.4	H (m)	30	26	20	15	12	8	5	-	-	-	-	-	-			
APm37	—	0.37	0.5		40	35	30	25	20	15	10	5	-	-	-	-	-	-		
APm60	—	0.6	0.8		60	55	50	40	35	30	25	20	10	5	-	-	-	-		
APm75	—	0.75	1.0		75	70	60	50	45	35	28	22	15	5	-	-	-	-		
APm90	—	0.75	1.0		90	75	60	50	35	25	15	5	-	-	-	-	-	-		
APm110	AP110	1.1	1.5		85	80	75	65	60	55	50	45	40	30	18	10	-	-		
APm150	AP150	1.5	2.0		90	86	80	75	70	65	60	55	50	40	30	20	10	-		
APm220	AP220	2.2	3.0		100	96	90	85	80	75	70	65	60	50	40	30	20	10		

### Dimension

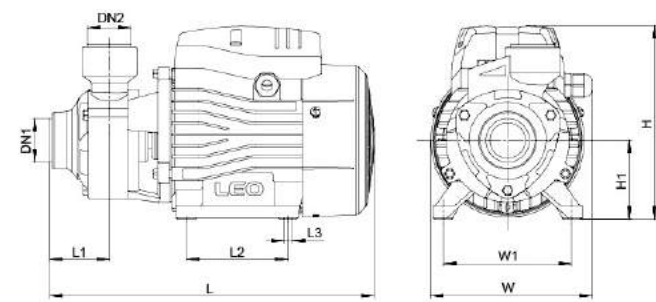

MODEL	DN1	DN2	L (mm)	W (mm)	H (mm)	L <sub>1</sub> (mm)	L <sub>2</sub> (mm)	L <sub>3</sub> (mm)	W <sub>1</sub> (mm)	H <sub>1</sub> (mm)
APm30			260	132	155	46.5	80	8.5	100	63
APm37			260	132	155	46.5	80	8.5	100	63
APm60	1"	1"	282	147	183	51	90	8.5	112	71
APm75			300	147	183	54.5	90	8.5	112	71
APm90	3/4"	3/4"	297	147	183	50	90	8.5	112	71
APm110			336	165	210	56	100	9	125	86
APm150	1"	1"	338	165	210	56	100	9	125	86
APm220			395	170	235	56	123	12	140	96
AP220			338	165	210	56	100	9	125	86

### Hydraulic Performance Curves

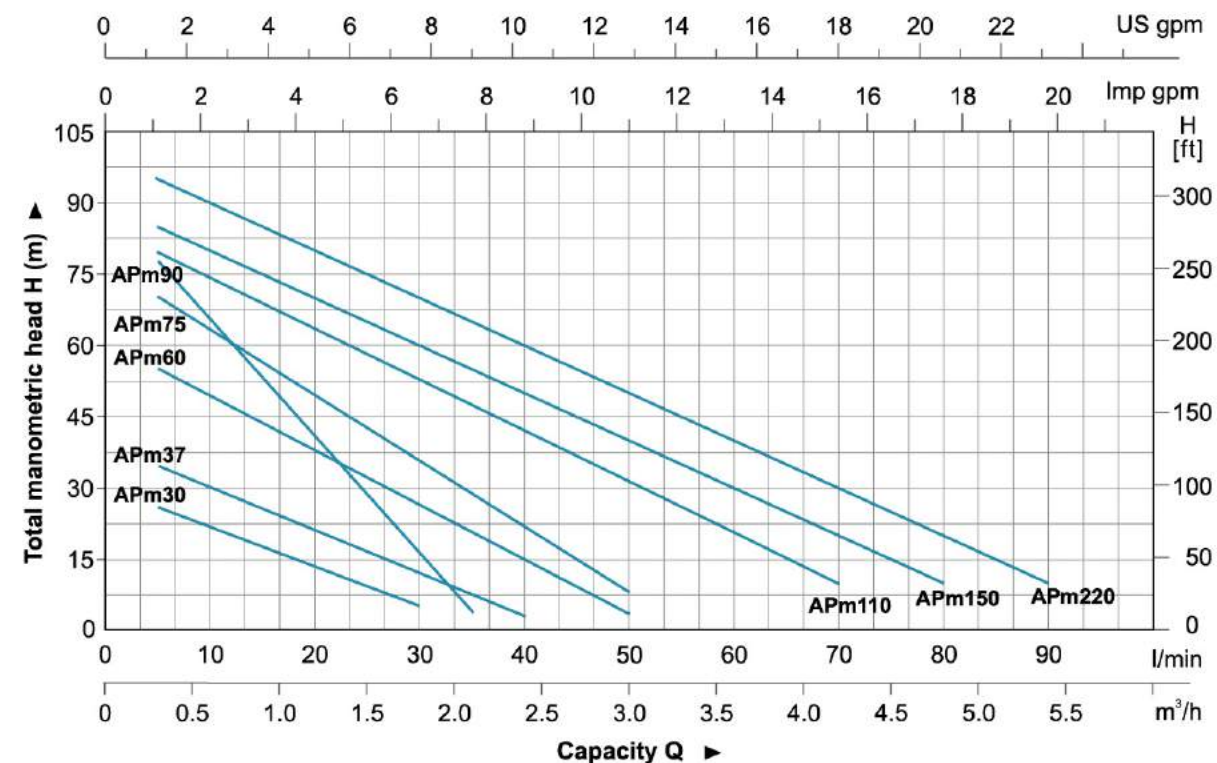

### Materials Table

No.	Part	Material
1	Pump body	HT200
2	Impeller	Brass
3	Mechanical seal	Carbon/Ceramic
4	O-ring	NBR
5	Support	HT200
6	Bearing	
7	Rotor	
8	Fan cover	PP
9	Fan	PP
10	Rear cover	ZL102
11	Capacitor	
12	Terminal box	PAG-GF25
13	Terminal board	PC
14	Stator	
15	Filling plug	HPb59-1

No.	APm220 Part	Material
14-1	Stator	
14-2	Base	PC+ABS

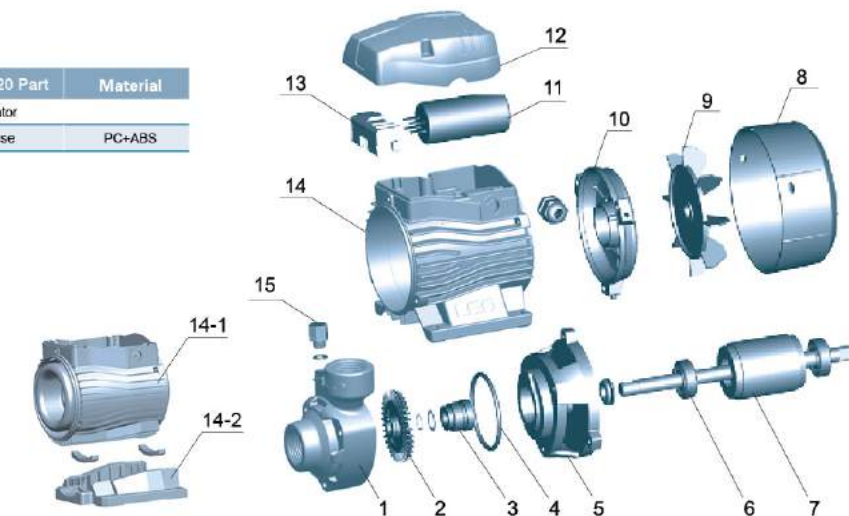

### Package Information

Model	GW (Kgs)	L (mm)	W (mm)	H (mm)	Quantity (PCS/20 TEU)
APm30	5.1	283	158	171	3132
APm37	5.5	283	158	171	3132
APm60	9.0	315	190	210	2365
APm75	10.5	335	190	210	2222
APm90	10.5	335	190	210	2222
APm110	15.9	370	210	235	1230
APm150	16.5	370	210	235	1230
APm220	22.3	420	225	265	955
AP220	17.2	370	210	235	1230







### Application

- Can be used to transfer clean water or other liquids similar to water in physical and chemical properties
- Suitable for small living water supply, automatic water sprinkler system, small air conditioner system or supporting equipment etc.

### Pump

- Special anti-rust treatment for cast iron pump body and support
- Anti-block system for impeller
- Brass impeller
- AISI 304 shaft
- Max. liquid temperature: +60°C
- Max. suction: +8 m

### Motor

- C&U bearing
- Motor with copper winding
- Built-in thermal protector for single phase motor
- Insulation class: F
- Protection class: IPX4
- Max. ambient temperature: +40°C
- IE 2 motor

### Identification Codes

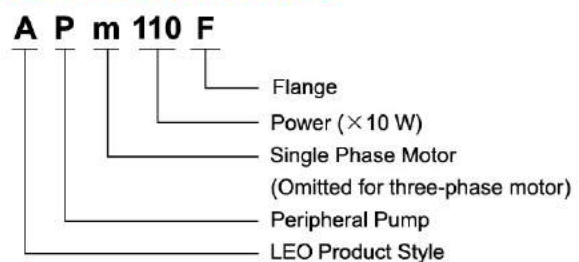

### Technical Data

Model		Power		Q(m <sup>3</sup> /h)															
Single Phase	Three Phase	kW	HP	Q(l/min)	0	0.3	0.6	0.9	1.2	1.5	1.8	2.1	2.4	3.0	3.6	4.2	4.8		
APm110F	AP110F	1.1	1.5	H(m)	85	80	75	65	60	55	50	45	40	30	18	10	-		
APm150F	AP150F	1.5	2.0		90	86	80	75	70	65	60	55	50	40	30	20	10		

### Hydraulic Performance Curves

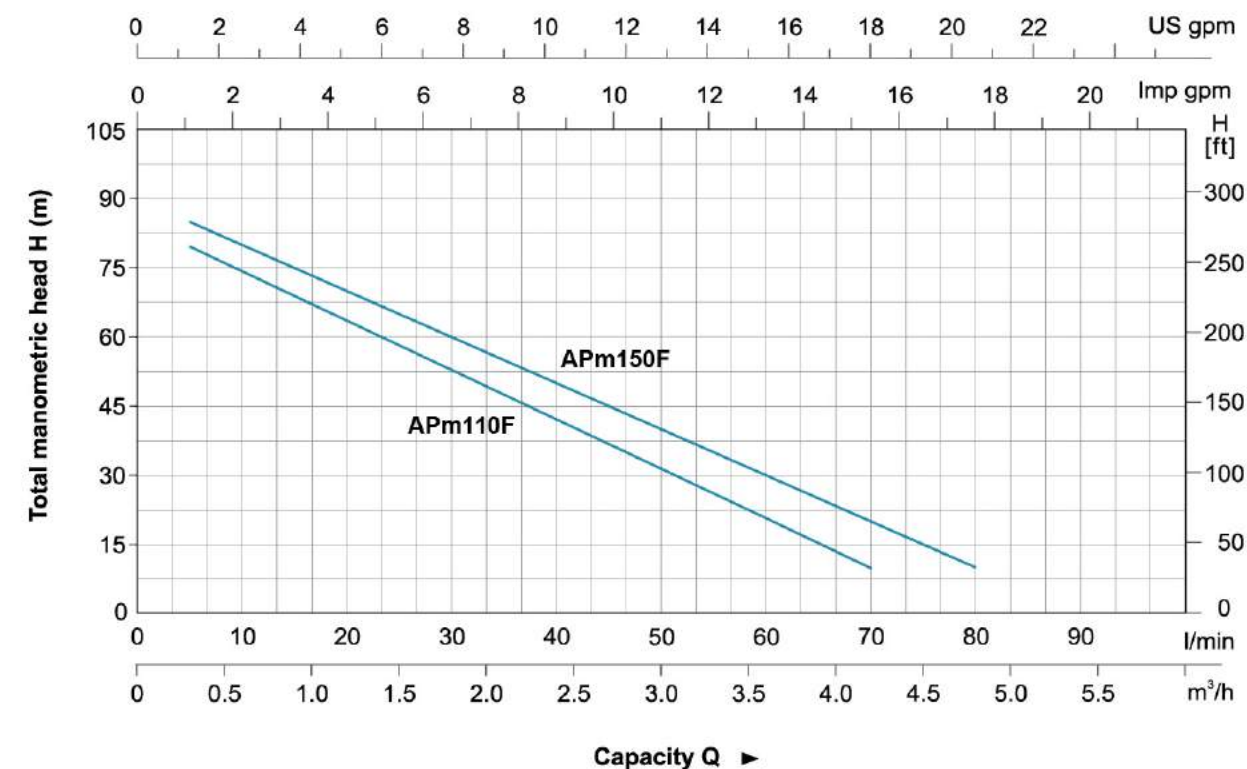

### Materials Table

No.	Part	Material	No.	Part	Material
1	Pump body	HT200	11	Capacitor	
2	Mechanical seal	Carbon/Ceramic	12	Terminal box	ABS
3	Impeller	Brass	13	Terminal board	PC
4	O-ring	NBR	14	Stator	
5	Support	HT200	15	Filling plug	HPb59-1
6	Bearing				
7	Rotor				
8	Fan cover	PP			
9	Fan	PP			
10	Rear cover	ZL102			

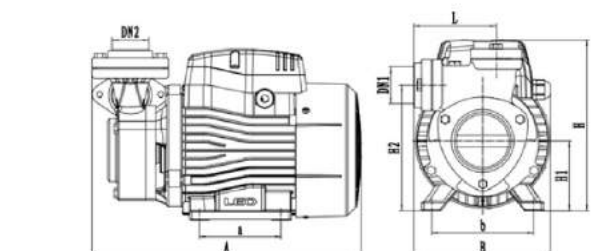
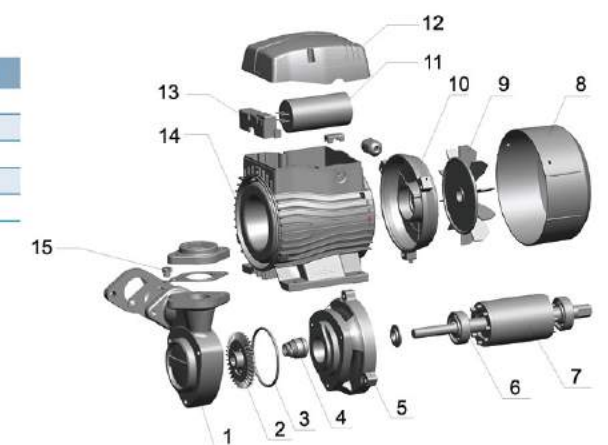

### Dimension

Model	DN1	DN2	A (mm)	B (mm)	L (mm)	a (mm)	b (mm)	H (mm)	H1 (mm)	H2 (mm)
APm110F	1.25"	1.25"	330	168	100	100	125	210	86	154.5
APm150F	1.25"	1.25"	332	168	100	100	125	210	86	154.5

### Package Information

Model	GW (kg)	L (mm)	W (mm)	H (mm)	Quantity (PCS/20 TEU)
APm110F	16.5	365	200	245	1240
APm150F	17.4	365	200	245	1180







### Application

- Can be used to transfer clean water or other liquids similar to water in physical and chemical properties
- Suitable for small living water supply, automatic water sprinkler system, small air conditioner system or supporting equipment etc.

### Pump

- Special anti-rust treatment for cast iron pump body and support
- Brass impeller
- AISI 304 shaft
- Max. liquid temperature: +60°C
- Max. suction: +8 m

### Motor

- C&U bearing
- Motor with copper winding
- Built-in thermal protector for single phase motor
- Insulation class: F
- Protection class: IPX4
- Max. ambient temperature: +40°C

### Identification Codes

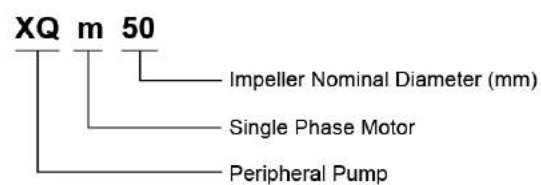

### Technical Data

Model	POWER		Q (m <sup>3</sup> /h)	0	0.3	0.6	0.9	1.2	1.5	1.8	2.1	2.4	2.7
	kW	HP		Q (l/min)	0	5	10	15	20	25	30	35	40
XQm50	0.125	0.15	<b>H (m)</b>	23	19	15	11	7	3	-	-	-	-

### Hydraulic Performance Curves

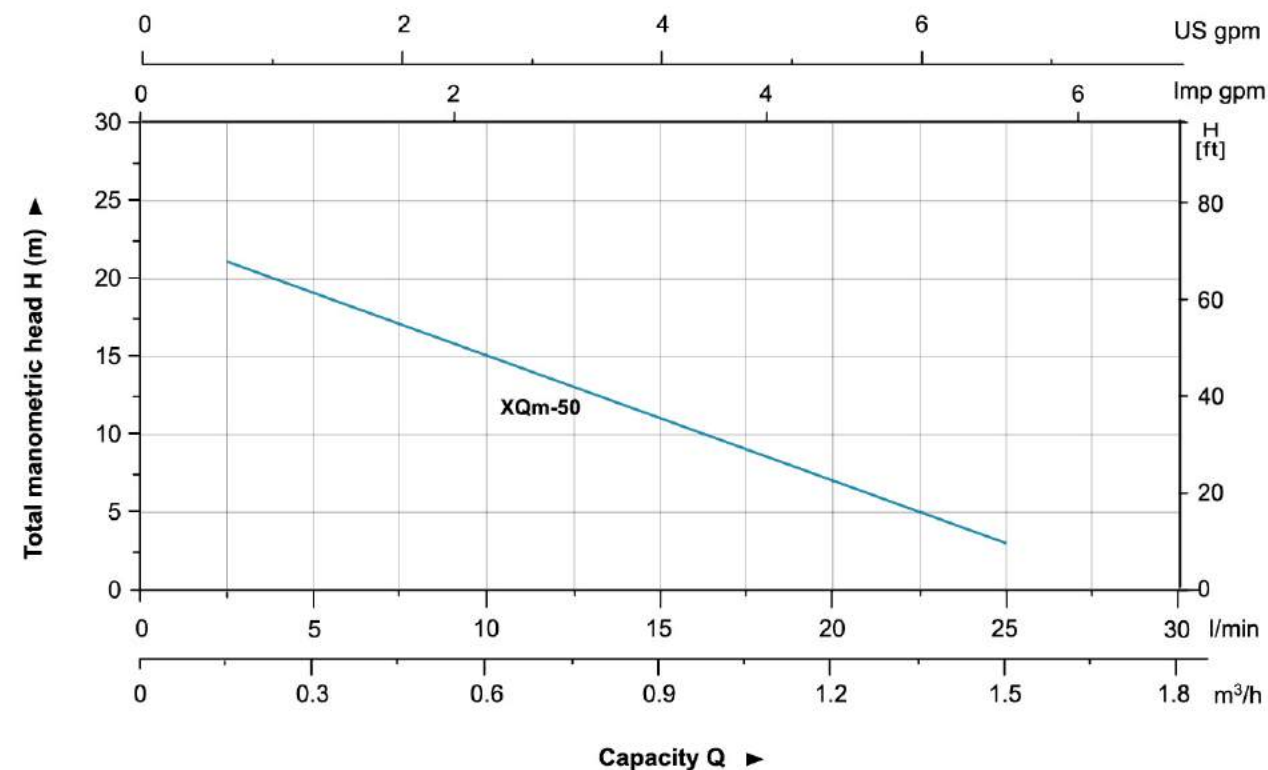

### Materials Table

No.	Part	Material
1	Pump body	HT200
2	Impeller	Brass
3	Mechanical seal	Carbon/Ceramic
4	O-ring	NBR
5	Support	HT200
6	Bearing	
7	Rotor	
8	Fan cover	08F
9	Fan	PP
10	Rear cover	ZL102
11	Capacitor	
12	Terminal box	ABS
13	Terminal board	PC
14	Stator	
15	Filling plug	HPb58-1

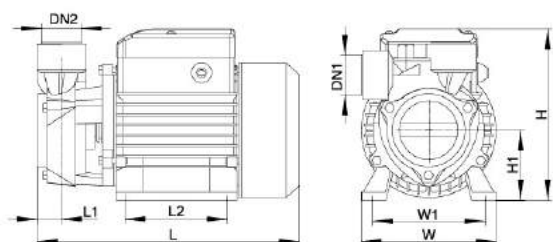
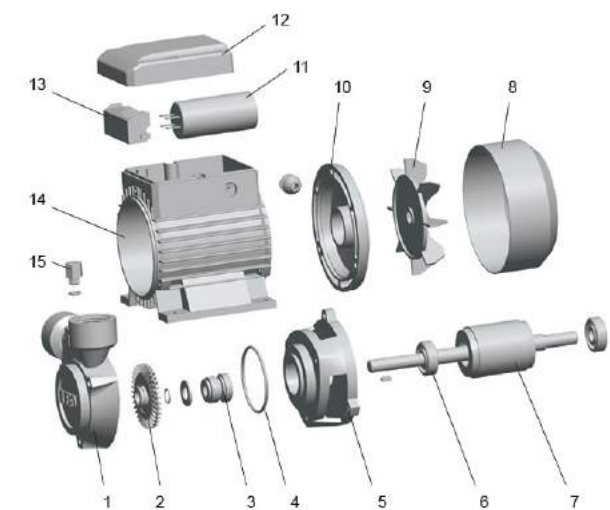

### Dimension

Model	DN1	DN2	L (mm)	W (mm)	H (mm)	L1 (mm)	L2 (mm)	W1 (mm)	H1 (mm)
XQm50	1"	1"	173	120	146	15	45	100	60

### Package Information

Model	GW (Kgs)	L (mm)	W (mm)	H (mm)	Quantity (PCS/20' TEU)
XQm50	3.6	180	140	162	5262







### Application

- Can be used to transfer clean water or other liquids similar to water in physical and chemical properties
- Suitable for small living water supply, automatic water sprinkler system, small air conditioner system or supporting equipment etc.

### Pump

- Special anti-rust treatment for cast iron pump body and support
- Brass impeller
- AISI 304 shaft
- Max. liquid temperature: +60°C
- Max. suction: +8 m

### Motor

- C&U bearing
- Motor with copper winding
- Built-in thermal protector for single phase motor
- Insulation class: F
- Protection class: IPX4
- Max. ambient temperature: +40°C

### Identification Codes

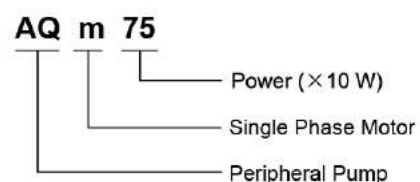

### Technical Data

Model	POWER		Q (m³/h)	Q (l/min)											
	kW	HP		0	0.3	0.6	0.9	1.2	1.5	1.8	2.1	2.4	2.7		
AQm37	0.37	0.5	<b>H (m)</b>	40	35	30	25	20	15	10	5	2	-		
AQm60	0.6	0.8		60	55	50	40	35	30	25	20	10	5		
AQm75	0.75	1		75	70	60	50	45	35	28	22	15	5		

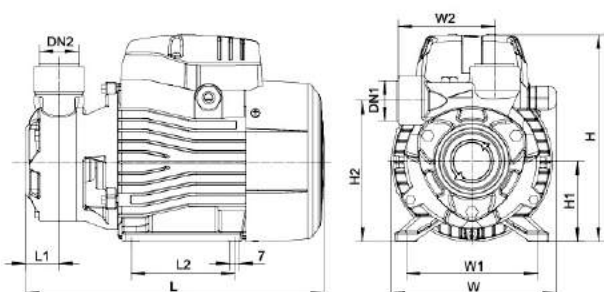

### Dimension

Model	DN1	DN2	L (mm)	W (mm)	H (mm)	L1 (mm)	L2 (mm)	W1 (mm)	W2 (mm)	H1 (mm)	H2 (mm)
AQm37	1"	1"	240	132	155	28.5	80	100	79	63	112
AQm60	1"	1"	265	147	183	29.5	90	112	85	71	124.5
AQm75	1"	1"	275	147	183	28.5	90	112	88	71	129

### Hydraulic Performance Curves

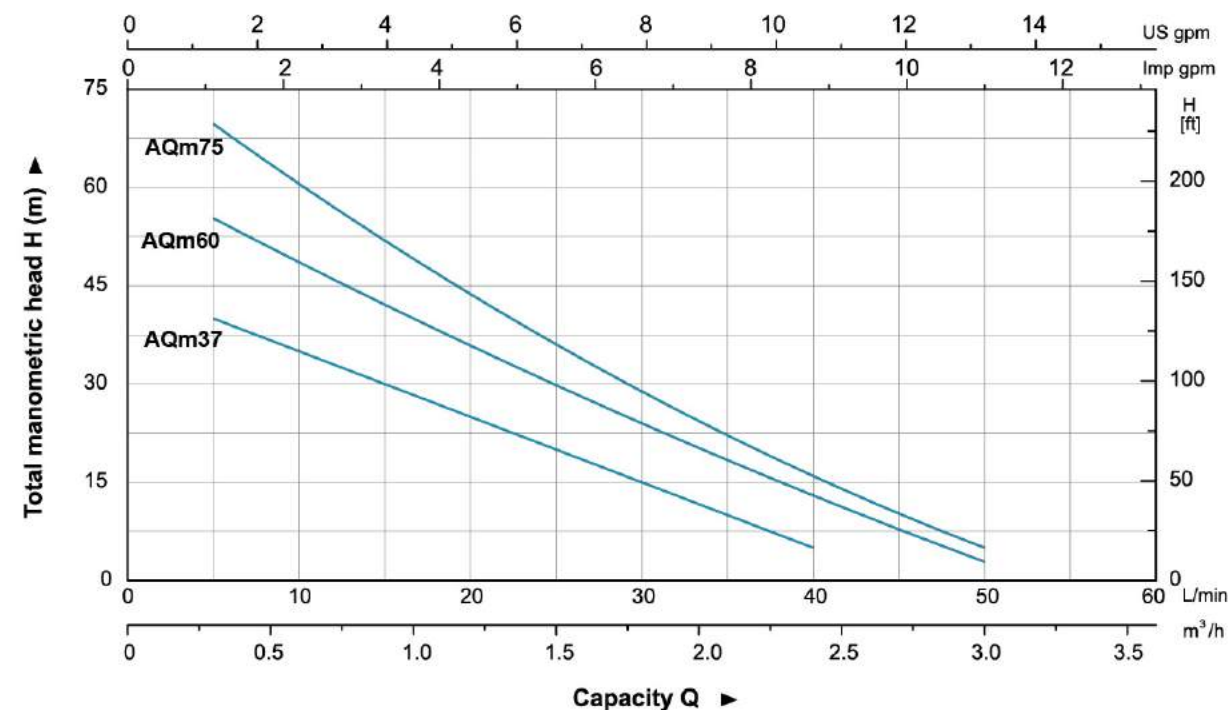

### Materials Table

No.	Part	Material
1	Pump body	HT200
2	Impeller	Brass
3	O-ring	NBR
4	Mechanical seal	Carbon/Ceramic
5	Support	HT200
6	Bearing	
7	Rotor	
8	Fan cover	08F
9	Fan	PP
10	Rear cover	ZL102
11	Capacitor	
12	Terminal box	PA6-GF25
13	Terminal board	PC
14	Stator	
15	Filling plug	HPb59-1

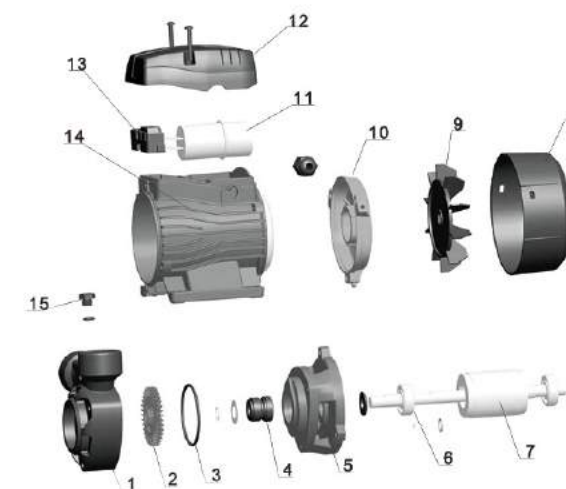

### Package Information

Model	GW (Kgs)	L (mm)	W (mm)	H (mm)	Quantity (PCS/20'TEU)
AQm37	6.1	277	158	174	3168
AQm60	9.8	337	190	210	1960
AQm75	10.8	350	190	210	1880







## Application

- Can be used to transfer clean water or other liquids similar to water in physical and chemical properties
- Suitable for small living water supply, automatic water sprinkler system, small air conditioner system or supporting equipment etc.

## Pump

- Special anti-rust treatment for cast iron pump body and support
- Anti-block system for impeller
- Brass impeller
- AISI 304 shaft
- Max. liquid temperature: +60°C
- Max. suction: +9 m
- Self-priming

## Motor

- C&U bearing
- Motor with copper winding
- Built-in thermal protector for single phase motor
- Insulation class: F
- Protection class: IPX4
- Max. ambient temperature: +40°C
- IE2 motor for APS110

## Identification Codes

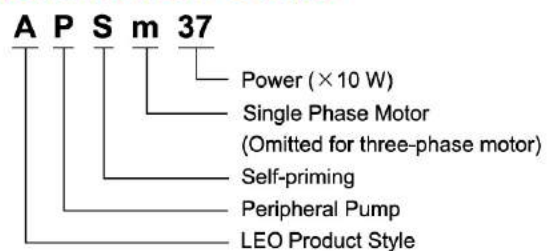

## Technical Data

MODEL		POWER		Q (m³/h)																										
Single Phase	Three Phase	kW	HP	0	0.3	0.6	0.9	1.2	1.5	1.8	2.1	2.4	3.0	3.3	3.6	4.2	Q (l/min)													
				H (m)																										
				0	5	10	15	20	25	30	35	40	50	55	60	70	0	5	10	15	20	25	30	35	40	45	50	55	60	70
APSm37	—	0.37	0.5	40	35	28	22	18	12	5	-	-	-	-	-	-	40	35	28	22	18	12	5	-	-	-	-	-	-	
APSm60	—	0.6	0.8	45	40	32	28	22	18	12	8	5	-	-	-	-	45	40	32	28	22	18	12	8	5	-	-	-	-	-
APSm75	—	0.75	1.0	55	50	42	38	32	28	22	18	12	5	-	-	-	55	50	42	38	32	28	22	18	12	5	-	-	-	-
APSm110	APS110	1.1	1.5	65	60	55	50	45	40	35	30	25	20	15	10	5	65	60	55	50	45	40	35	30	25	20	15	10	5	-

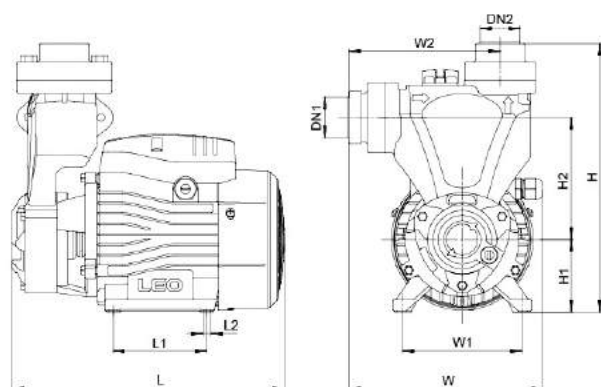

## Dimension

Model	DN1	DN2	L (mm)	W (mm)	H (mm)	L <sub>1</sub> (mm)	W <sub>1</sub> (mm)	W <sub>2</sub> (mm)	H <sub>1</sub> (mm)	H <sub>2</sub> (mm)	L <sub>2</sub> (mm)
APSm37	1"	1"	239	170	234	80	100	128	63	106	8.5
APSm60	1"	1"	260	180	251	90	112	132	71	120	8.5
APSm75	1"	1"	270	180	260	90	112	142	71	130	8.5
APSm110	1 1/2"	1 1/2"	310	200	284	100	125	149	86	138	9

## Hydraulic Performance Curves

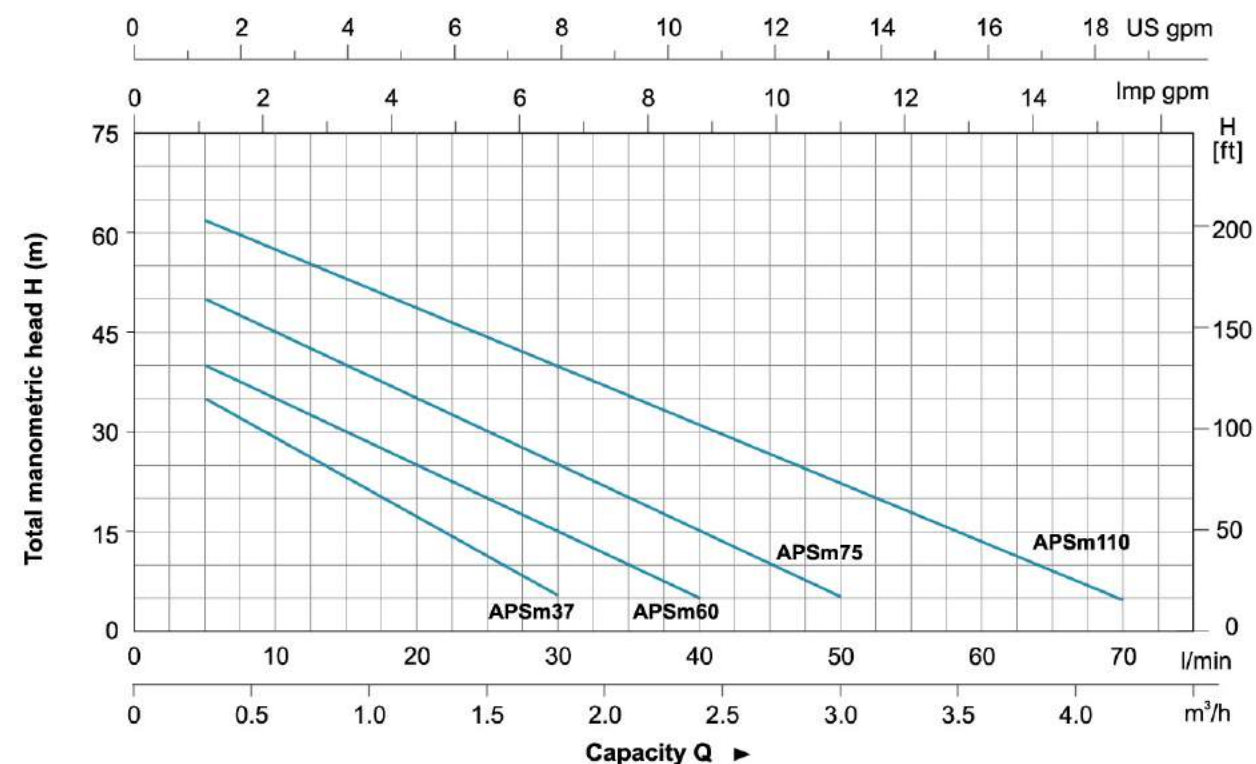

## Materials Table

No.	Part	Material
1	Screw	Steel
2	Pump body	HT200
3	Impeller	Brass
4	Mechanical seal	Carbon/Ceramic
5	O-ring	NBR
6	Support	HT200
7	Bearing	
8	Rotor	
9	Fan cover	PP
10	Fan	PP
11	Rear cover	ZL102
12	Capacitor	
13	Terminal box	PA6-GF25
14	Stator	
15	Terminal board	PC
16	Non-return valve	NBR
17	Connector	HT200

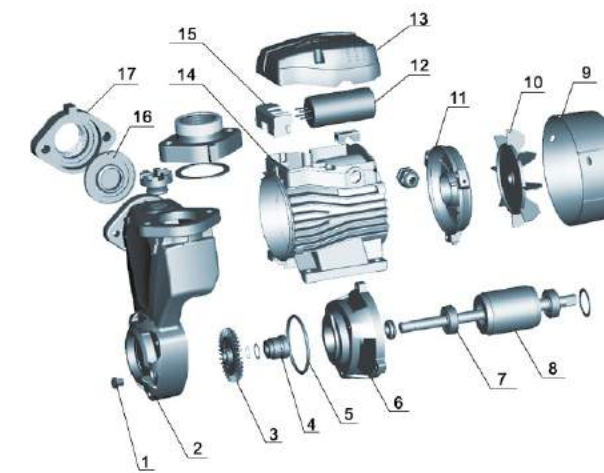

## Package Information

Model	GW (Kgs)	L (mm)	W (mm)	H (mm)	Quantity (PCS/20 TEU)
APSm37	7.2	275	200	265	2040
APSm60	10.8	290	205	285	1736
APSm75	12.3	305	214	290	1365
APSm110	17.5	345	232	320	998







### Application

- Can be used to transfer clean water or other liquids similar to water in physical and chemical properties
- Suitable for small living water supply, automatic water sprinkler system, small air conditioner system or supporting equipment etc.

### Pump

- Special anti-rust treatment
- Brass impeller
- AISI 304 shaft
- Max. liquid temperature: +60°C
- Max. suction: +8 m

### Motor

- C&U bearing
- Copper winding
- Built-in thermal protector
- Insulation class: F
- Protection class: IPX4
- Max. ambient temperature: +40°C

### Identification Codes

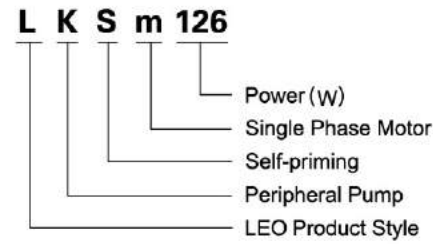

### Technical Data

MODEL	POWER		Q (m³/h)	H (m)											
	kW	HP		Q (l/min)	0	0.3	0.6	0.9	1.2	1.5	1.8	2.1	2.4	2.7	
LKSm126	0.125	0.17	30	25	20.5	16	12	8	4	-	-	-	-	-	
LKSm350	0.35	0.47	35	32	28	24	20	16	12	8	4	-	-	-	
LKSm550	0.55	0.75	45	40	35	30	25	20.5	16	12	8	4	-	-	

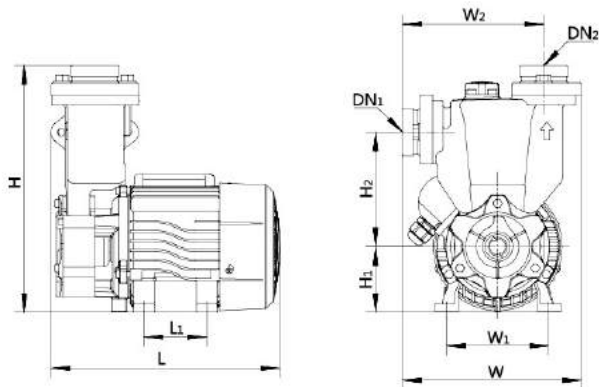

### Dimension

Model	DN1	DN2	L (mm)	W (mm)	H (mm)	L <sub>1</sub> (mm)	W <sub>1</sub> (mm)	W <sub>2</sub> (mm)	H <sub>1</sub> (mm)	H <sub>2</sub> (mm)
LKSm126	1"	1"	215	170	220	60	97	140	63	88.5
LKSm350	1"	1"	215	175	245	60	97	142	63	110
LKSm550	1"	1"	260	186	260	90	112	152	75	113.5

### Hydraulic Performance Curves

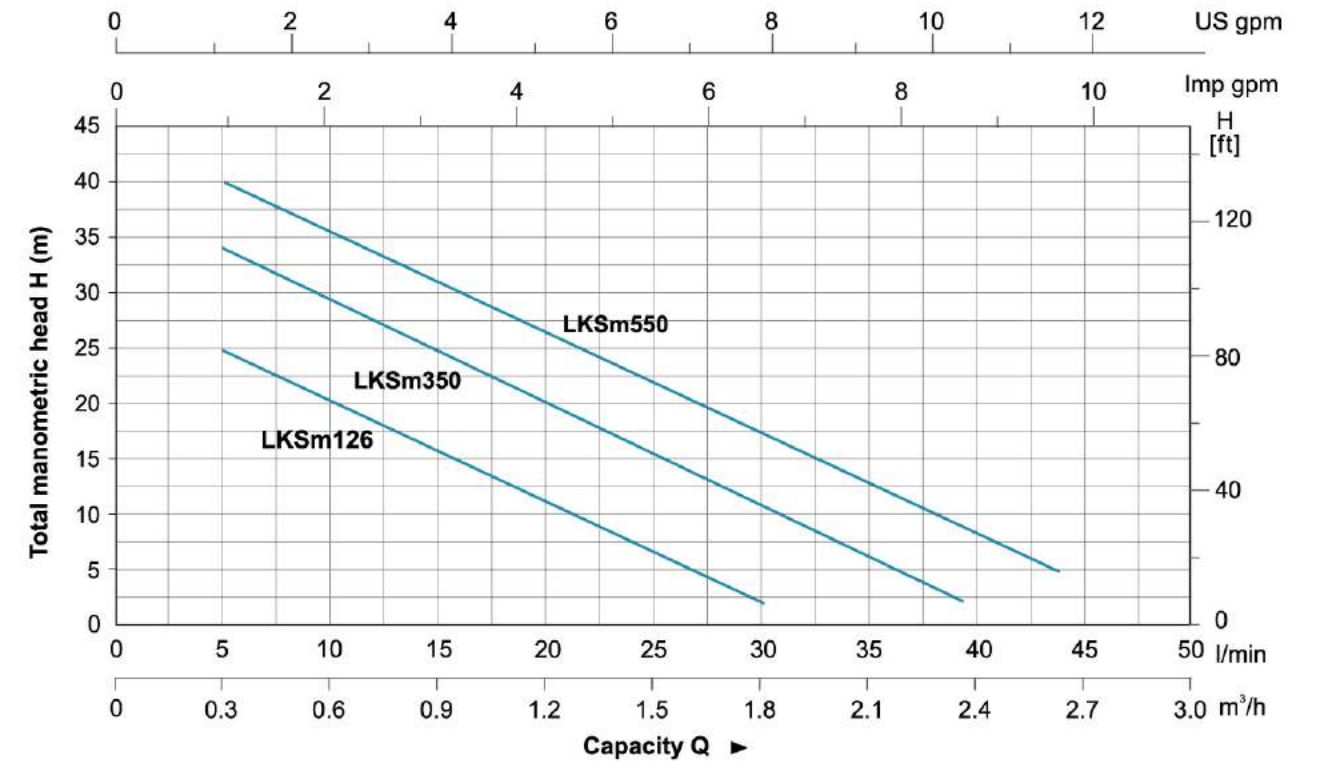

### Materials Table

No.	Part	Material
1	Pump bonnet	Brass/Cast iron
2	Impeller	Brass
3	Mechanical seal	Carbon/Ceramic
4	Pump body	HT200
5	Check valve	NBR
6	Outlet connector	HT200
7	Filling plug	Brass
8	Front plate	HT200
9	Bearing	
10	Rotor	
11	Fan cover	PP
12	Fan	PP
13	Rear cover	ZL 102
14	Stator	
15	Capacitor	
16	Sealing ring	NBR
17	Terminal box	ABS

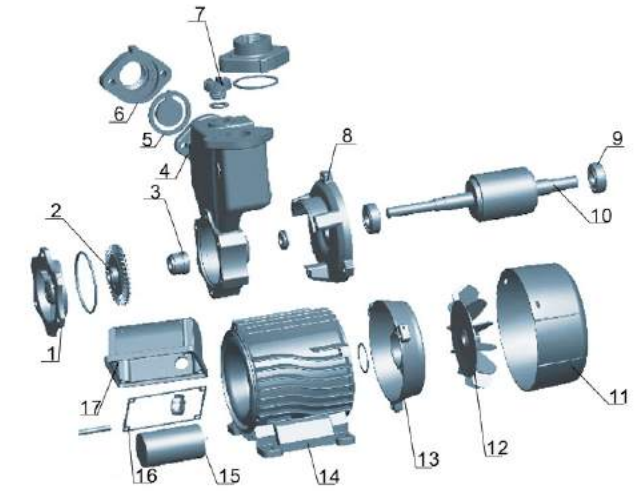

### Package Information

Model	GW (Kgs)	L (mm)	W (mm)	H (mm)	Quantity (PCS/20 TEU)
LKSm126	6.6	250	205	250	2205
LKSm350	7.6	250	205	270	1960
LKSm550	10.6	295	210	290	1526







### Application

- Can be used to transfer clean water or other liquids similar to water in physical and chemical properties
- Suitable for small living water supply, automatic water sprinkler system, small air conditioner system or supporting equipment etc.

### Pump

- With 2 L pressure tank for automatic operation
- Special anti-rust treatment
- Brass impeller
- AISI 304 shaft
- Max. liquid temperature: +60°C
- Max. suction: +9m

### Motor

- C&U bearing
- Copper winding
- Built-in thermal protector
- Insulation class: F
- Protection class: IPX4
- Max. ambient temperature: +40°C

### Identification Codes

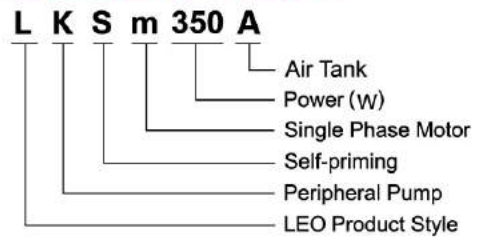

### Technical Data

MODEL	POWER		Q (m³/h)	H (m)												
	kW	HP		0	0.3	0.6	0.9	1.2	1.5	1.8	2.1	2.4	2.7	3		
LKSm130	0.125	0.17	Q (l/min)	0	5	10	15	20	25	30	35	40	45	50		
LKSm350A	0.35	0.47	30	25	20.5	16	12	8	4	-	-	-	-	-		
LKSm550A	0.55	0.75	35	32	28	24	20	16	12	8	4	-	-	-		
LKSm750A	0.75	1	45	40	35	30	25	20.5	16	12	8	4	-	-		
			55	50	45	40	35	30	25	20	15	10	5			

### Hydraulic Performance Curves

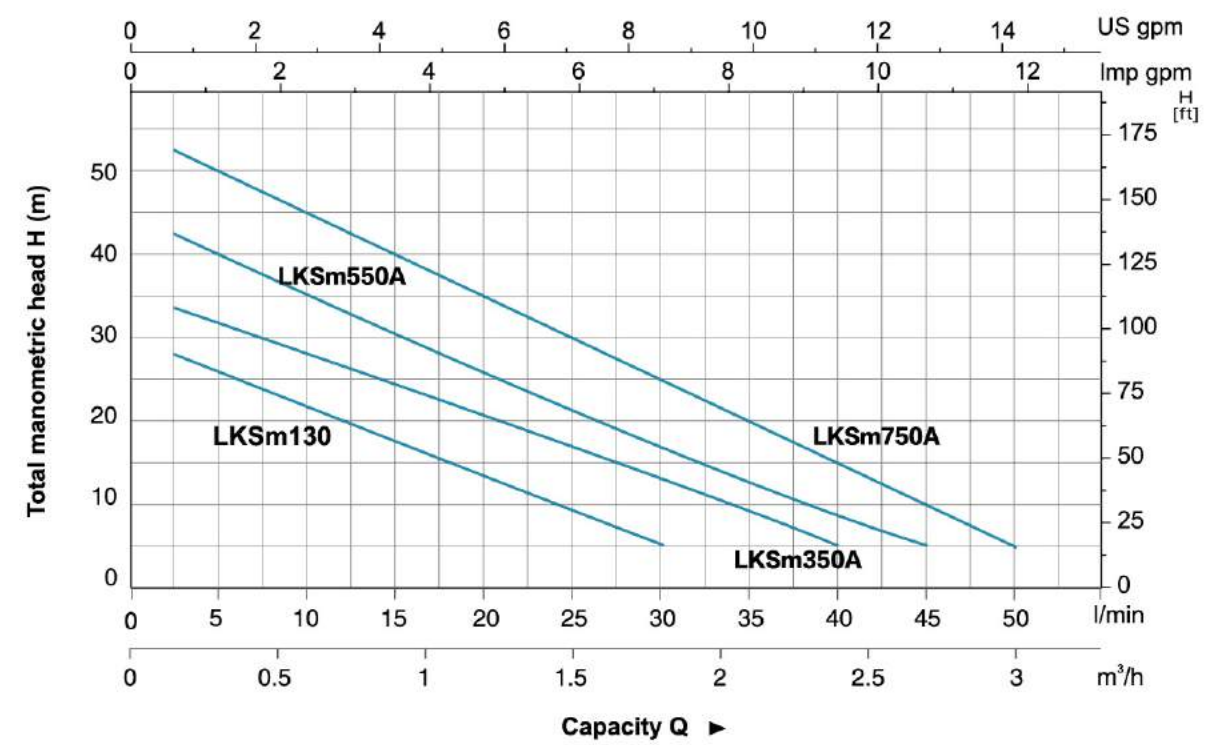

### Materials Table

No.	Part	Material	No.	Part	Material
1	Pump bonnet	Brass/Cast iron	18	Capacitor	
2	Impeller	Brass	19	Cable holder	NBR
3	Mechanical seal	Carbon/Ceramic	20	Sealing ring	NBR
4	Pump body	HT200	21	Terminal box	ABS
5	Check valve	NBR			
6	Outlet connector	HT200			
7	Filling plug	Brass			
8	Front plate	HT200			
9	Bend	Iron			
10	Pressure switch				
11	Pressure tank	Iron			
12	Bearing				
13	Rotor				
14	Fan cover	PP			
15	Fan	PP			
16	Rear cover	ZL102			
17	Stator				

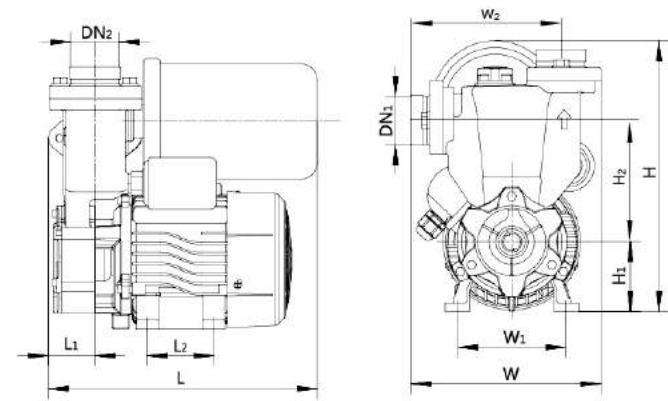
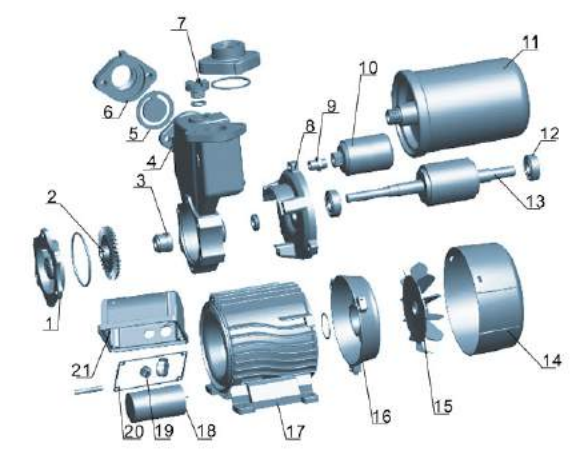

### Dimension

Model	DN1	DN2	L (mm)	W (mm)	H (mm)	L <sub>1</sub> (mm)	W <sub>1</sub> (mm)	W <sub>2</sub> (mm)	H <sub>1</sub> (mm)	H <sub>2</sub> (mm)
LKSm130	1"	1"	265	165	245	60	97	140	63	107.5
LKSm350A	1"	1"	265	165	250	60	97	135	63	110
LKSm550A	1"	1"	265	176	260	90	112	146	75	113.5
LKSm750A	1"	1"	265	176	260	90	112	146	75	113.5

### Package Information

Model	GW (Kgs)	L (mm)	W (mm)	H (mm)	Quantity (PCS/20' TEU)
LKSm130	7.8	285	195	290	1603
LKSm350A	8.6	285	195	290	1603
LKSm550A	11.6	290	215	305	1400
LKSm750A	13.5	290	215	310	1400







### Application

- Can be used to transfer clean water or other liquids similar to water in physical and chemical properties
- Suitable for small living water supply, automatic water sprinkler system, small air conditioner system or supporting equipment etc.

### Pump

- 3-second time delay of pump start after plugging into the socket to avoid potential danger caused by electric sparks
- Automatic stop in 6 minutes in case of no water inside
- Automatic switching to small flow control system in condition of small water flow
- Automatic 10-second operation every 120 hours for anti-block protection in case of no use for long time
- Anti-freezing in low temperature environment by automatic start and stop control to maintain the water temperature inside pump between 4°C and 60°C
- LCD screen with on/off pressure setting, operation status and malfunction alarm

### Motor

- C&U bearing
- Motor with copper winding
- Built-in thermal protector for single phase motor
- Insulation class: F
- Protection class: IPX4
- Max. ambient temperature: +40°C

### Identification Codes

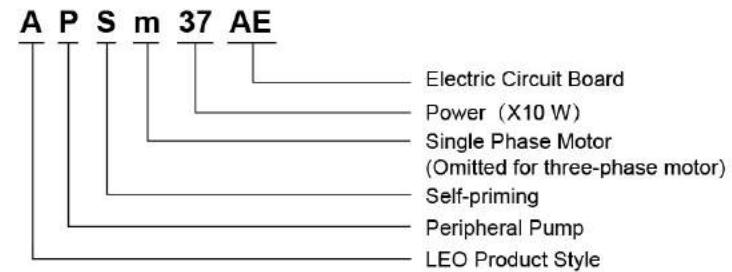

### Technical Data

MODEL	POWER		Q (m³/h)	Q (l/min)												
	kW	HP		0	0.3	0.6	0.9	1.2	1.5	1.8	2.1	2.4	2.7	3.0		
APSm25AE	0.25	0.33	H (m)	0	5	10	15	20	25	30	35	40	45	50		
APSm37AE	0.37	0.5		30	25	20.5	15	11	7	3	-	-	-	-		
APSm60AE	0.6	0.8		40	35	30	25	20.5	16	11	7	2.5	-	-		
APSm75AE	0.75	1.0		50	45	38	31.5	25.5	20.5	15.5	11	6.5	3	-		
				63	58	49	41	34	27.5	22	17	12	7	3		

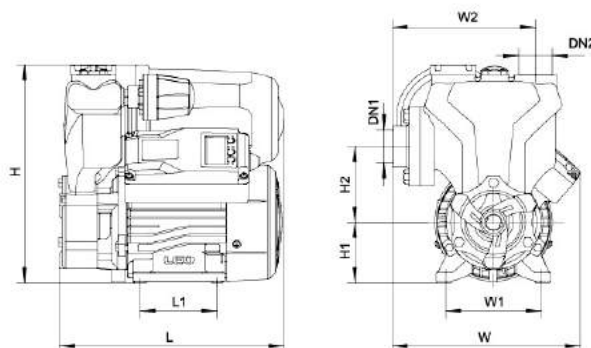

### Dimension

Model	DN1	DN2	L (mm)	W (mm)	H (mm)	L <sub>1</sub> (mm)	W <sub>1</sub> (mm)	W <sub>2</sub> (mm)	H <sub>1</sub> (mm)	H <sub>2</sub> (mm)
APSm25AE	1"	1"	235	195	228	80	100	150	63	80
APSm37AE			235	198	228	80	100	150	63	80
APSm60AE			270	224	242	90	112	162	71	85
APSm75AE			270	224	242	90	112	162	71	85

### Hydraulic Performance Curves

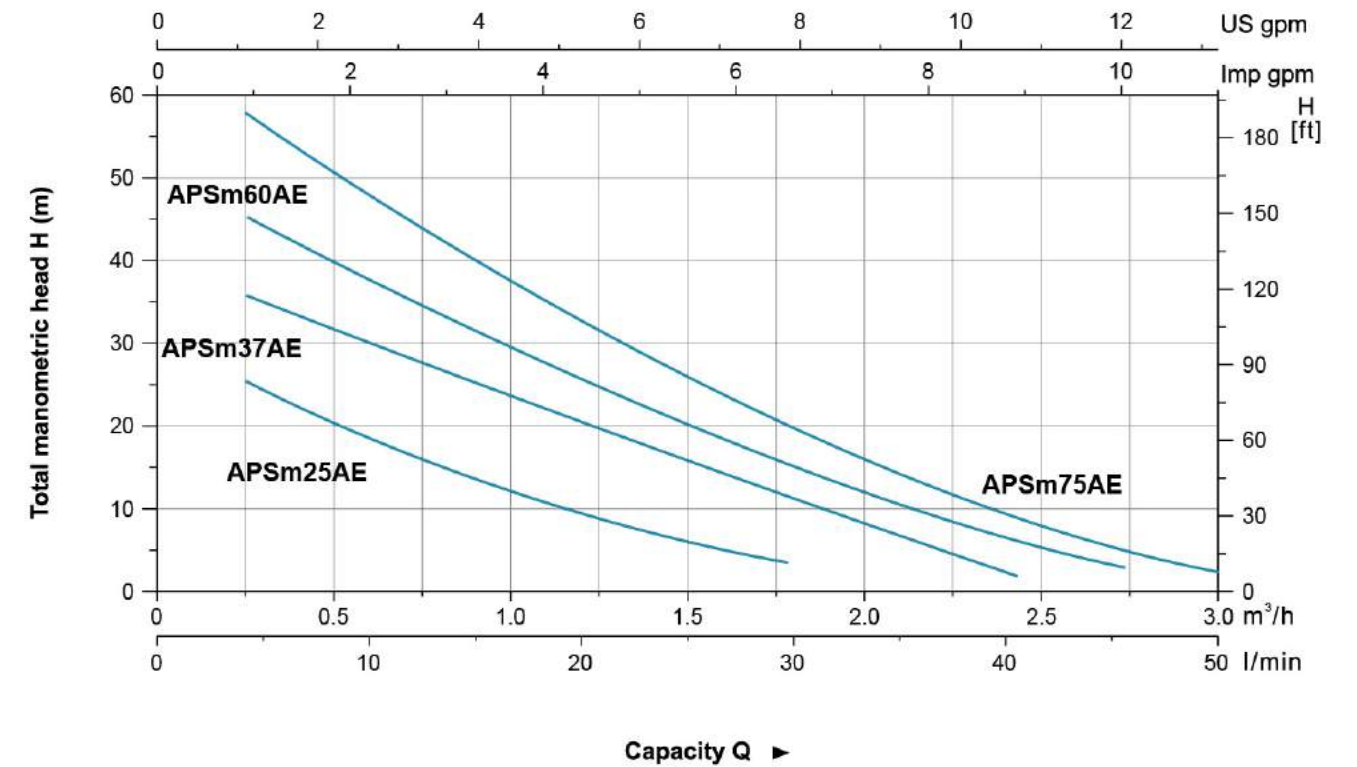

### Materials Table

No.	Part	Material	No.	Part	Material
1	Pump cover	Brass	11	Pressure sensor	
2	Impeller	Brass	12	Gas tank	Iron
3	Mechanical seal	Carbon/Ceramic	13	Cover the lid	PA6-GF25
4	Pump body	HT200	14	Capacitance	
5	Support	HT200	15	Cover box	PA6-GF25
6	Bearing		16	Stator	
7	Rotor		17	Pump head	PA66
8	Fan cover	PP	18	Check-valve spring	AISI 304
9	Fan	PP	19	Check valve	PPO
10	End plate	ZL102	20	Inlet connection	HT200

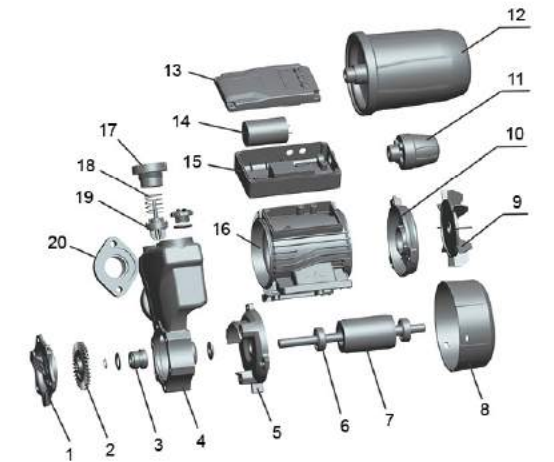

### Package Information

Model	GW (Kgs)	L (mm)	W (mm)	H (mm)	Quantity (PCS/20' TEU)
APSm25AE	9.23	290	245	275	1408
APSm37AE	10.1	290	245	275	1408
APSm60AE	13.1	315	285	300	980
APSm75AE	14.06	315	285	300	980







### Application

- Can be used to transfer clean water or other liquids similar to water in physical and chemical properties
- Suitable for small living water supply, automatic water sprinkler system, small air conditioner system or supporting equipment etc.

### Pump

- With 24L pressure tank for automatic operation
- Special anti-rust treatment
- Brass impeller
- AISI 304 shaft
- Max. liquid temperature: +60°C
- Max. suction: +9m

### Motor

- C&U bearing
- Copper winding
- Built-in thermal protector
- Insulation class: F
- Protection class: IPX4
- Max. ambient temperature: +40°C

### Identification Codes

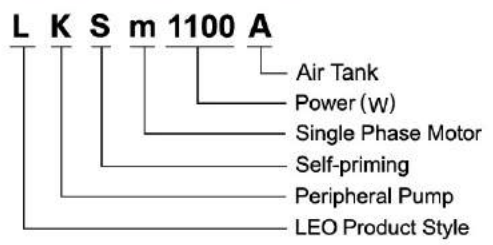

### Technical Data

MODEL	POWER		Q (m³/h)	Capacity Q															
	kW	HP		0	0.3	0.6	0.9	1.2	1.5	1.8	2.1	2.4	2.7	3	3.3	3.6	3.9	4.2	
LKSm1100A	1.1	1.5	<b>H (m)</b>	60	56	52	48	44	40	36	32	28	24	20	16	12	8	4	

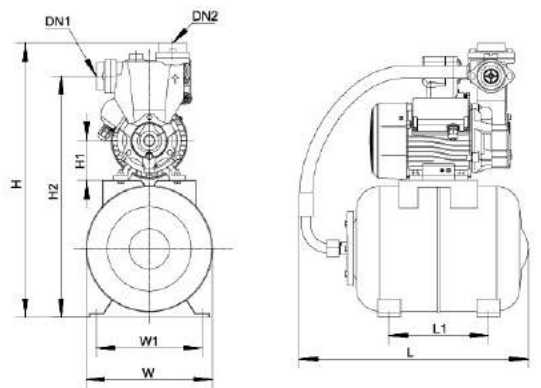

### Dimension

Model	DN1	DN2	L (mm)	W (mm)	H (mm)	L1 (mm)	W1 (mm)	H1 (mm)	H2 (mm)
LKSm1100A	1 1/2"	1 1/2"	480	270	595	220	235	86	520

### Hydraulic Performance Curves

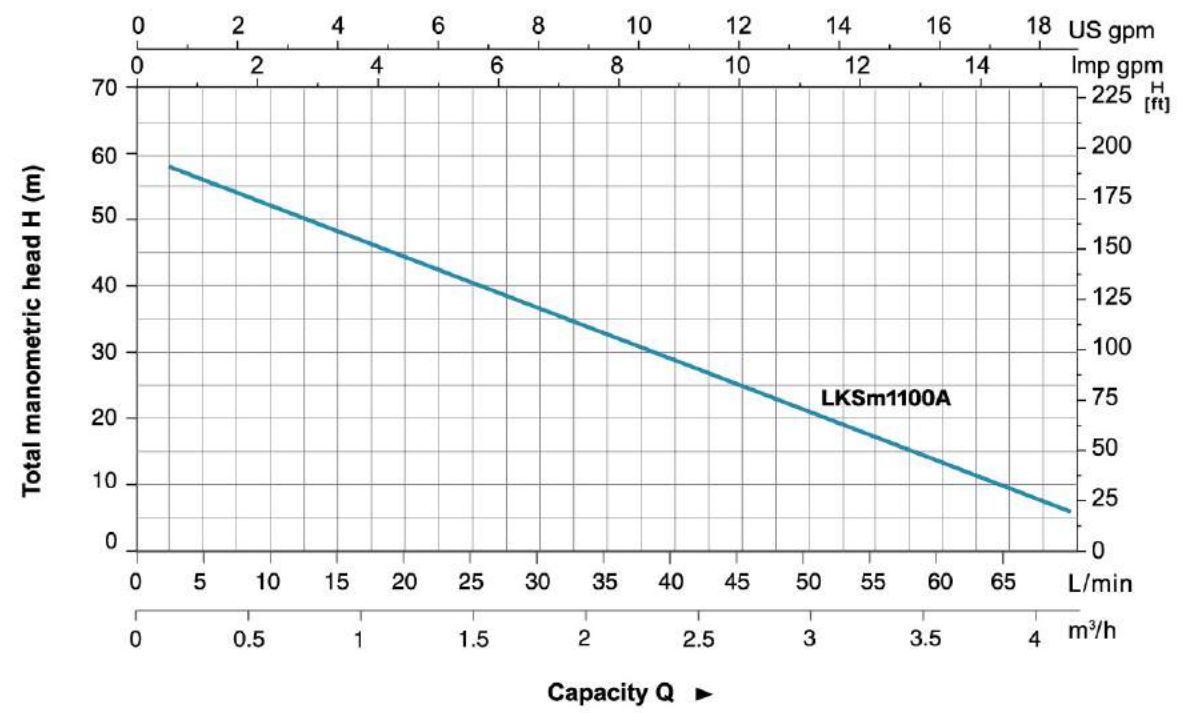

### Materials Table

No.	Part	Material	No.	Part	Material
1	Air tank	Iron	12	Mechanical seal	Carbon/Ceramic
2	Stator		13	Impeller	Brass
3	Rear cover	ZL102	14	O-ring	NBR
4	Fan	PP	15	Screw	Steel
5	Fan cover	PP	16	Pump bonnet	Brass
6	Flexible hose		17	Pump body	HT200
7	Terminal box	ABS	18	Check valve	NBR
8	Rotor		19	Outlet connector	HT200
9	Bearing		20	Filling plug	Brass
10	Capacitor		21	Pressure switch	
11	Front plate	HT200			

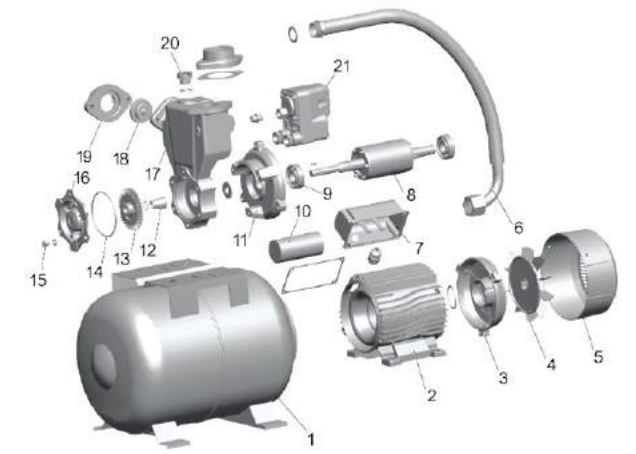

### Package Information

Model	GW (Kgs)	L (mm)	W (mm)	H (mm)	Quantity (PCS/20 TEU)
LKSm1100A	24	515	325	645	234







### Application

- Can be used to transfer clean water or other liquids similar to water in physical and chemical properties
- Suitable for small living water supply, automatic water sprinkler system, small air conditioner system or supporting equipment etc.

### Pump

- Self-priming Peripheral Pump
- Brass impeller
- Brass pump bonnet
- AISI 304 shaft
- 3 second time delay of pump start after plugging into the socket to avoid potential danger caused by electric sparks
- Automatic pressure sensor inside
- Automatic switching to small flow control system in condition of small water flow
- Automatic stop in 6 minutes in case of no water inside
- Max. liquid temperature: +60°C
- Max. suction: +8 m
- Liquid pH value: 6.5 – 8.5

### Motor

- C&U bearing
- Copper winding
- Built-in thermal protector
- Low voltage operation with power design of 180V - 220V/50 Hz

### Identification Codes

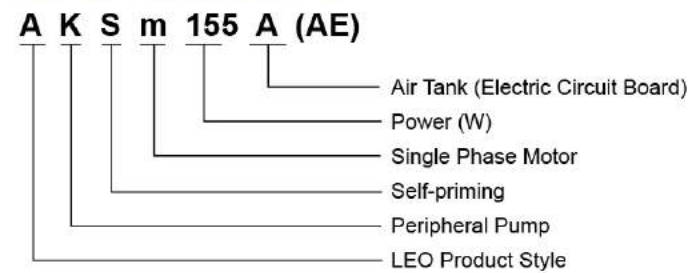

### Technical Data

MODEL	POWER		Q (m <sup>3</sup> /h)	0	0.3	0.6	0.9	1.2	1.5	1.8	2.1
	kW	HP		Q (l/min)	0	5	10	15	20	25	30
AKSm155A (AE)	0.155	0.2	<b>H(m)</b>	32	30	26	22	17	12	7	2

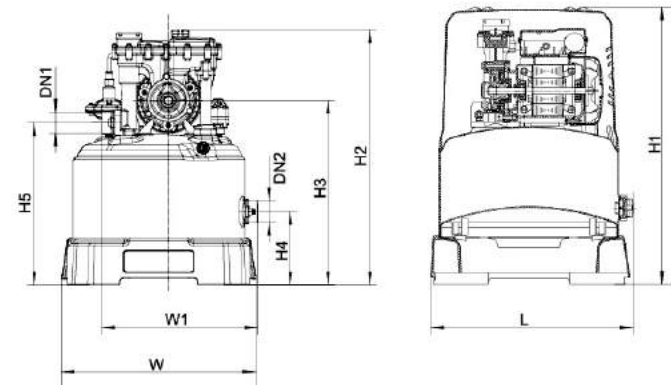

### Dimension

Model	DN1	DN2	L (mm)	W (mm)	W1 (mm)	H1 (mm)	H2 (mm)	H3 (mm)	H4 (mm)	H5 (mm)
AKSm155A (AE)	1"	1"	355	360	288	490	470	342	135	300

### Hydraulic Performance Curves

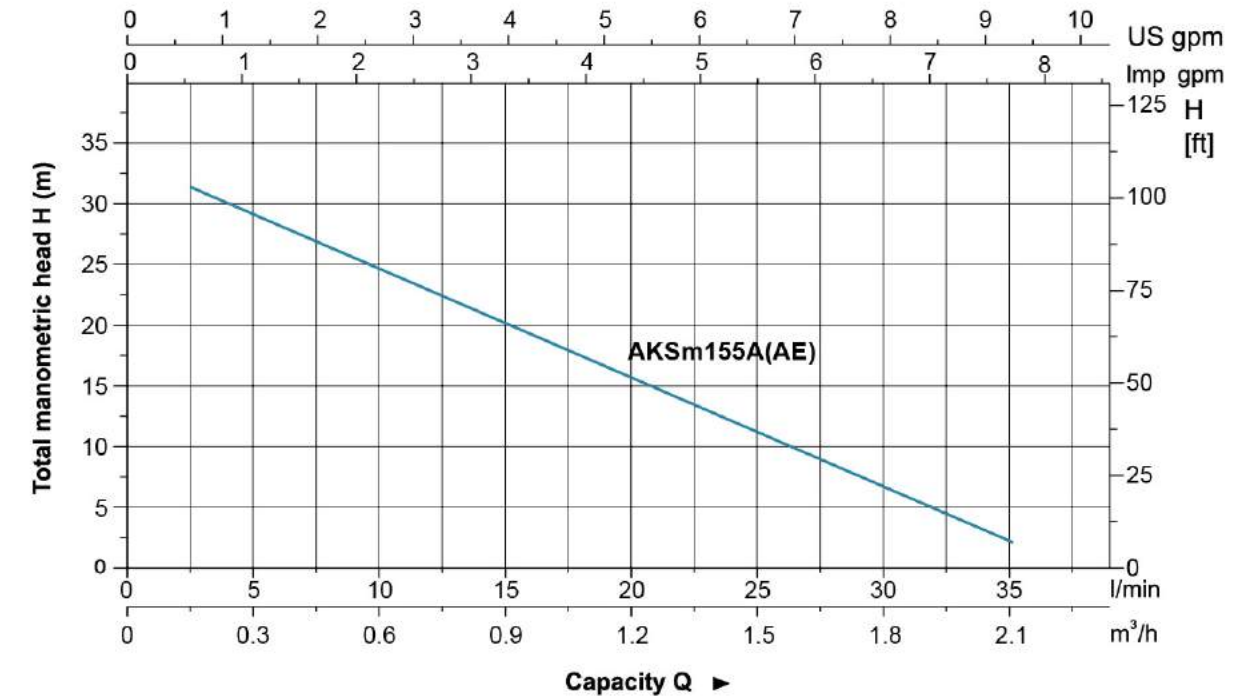

### Materials Table

No.	Part	Material
1	Base	PP
2	Tank	Steel (ST12)
3	Impeller	Brass
4	Non-return valve	PPO
5	Pump head cover	PA66
6	Pump head	POM
7	Circuit board	
8	Capacitor	
9	Terminal box	PA6-GF25
10	Stator	
11	Rear cover	ZL102
12	Fan	PP
13	Fan cover	PP
14	Housing	PP
15	Bearing	
16	Rotor	
17	Mechanical seal	Carbon/Ceramic
18	Pressure switch	
19	Air charger	
20	Pump bonnet	Brass
21	Pump body	POM

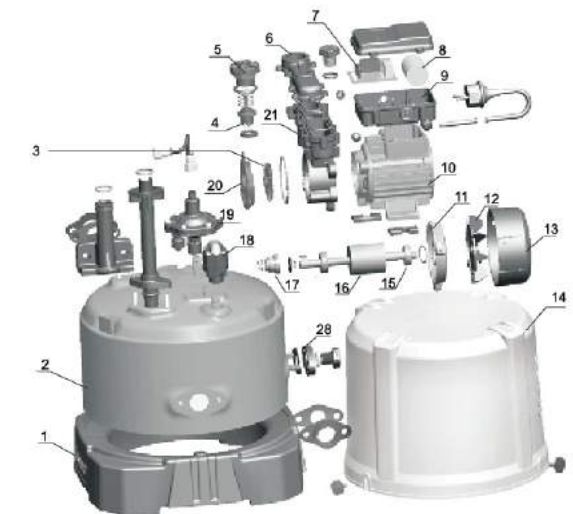

### Package Information

Model	GW (Kgs)	L (mm)	W (mm)	H (mm)	Quantity (PCS/20 TEU)
AKSm155A (AE)	13.6	405	405	530	320







### Application

- Can be used to transfer clean water or other liquids similar to water in physical and chemical properties
- Suitable for lifting water from the well, sprinkling irrigation in garden, pressure boosting of running water, and supporting equipment etc.

### Pump

- Stainless steel pump body
- Support under special anti-rust treatment
- Stainless steel impeller
- AISI 304 shaft
- Max. liquid temperature: +60°C
- Max. suction: +9 m

### Motor

- C&U bearing
- Motor with copper winding
- Built-in thermal protector for single phase motor
- Insulation class: F
- Protection class: IPX4
- Max. ambient temperature: +40°C

### Identification Codes

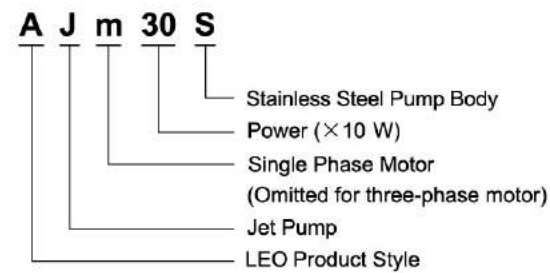

### Technical Data

MODEL	POWER		Q (m³/h)	Q (l/min)												
	kW	HP		0	0.6	0.6	0.9	1.2	1.5	1.8	2.1	2.4	2.8	3.0	3.3	3.6
AJm30S	0.3	0.4	H (m)	30	26	23	20	18	16.5	15	13	11	-	-	-	-
AJm45S	0.45	0.6		38	35	31	27	25	22	20	19	16	-	-	-	-
AJm60S	0.6	0.8		43	37	33	30	27	25	23	21	20	18	-	-	-
AJm75S	0.75	1.0		46	40	38	36	34	32	30	28	27	25	23	20	-
AJm90S	0.9	1.2		48	44	42	39	37	35	34	31	31	29	28	26	22

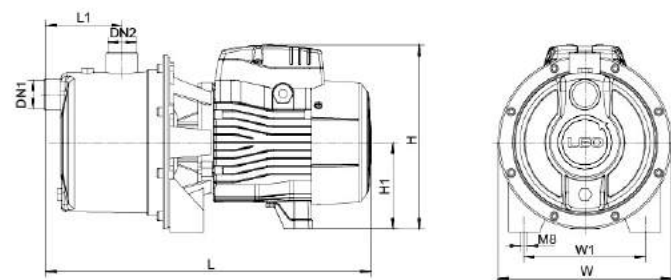

### Dimension

Model	DN1	DN2	L (mm)	W (mm)	H (mm)	L <sub>1</sub> (mm)	W <sub>1</sub> (mm)	H <sub>1</sub> (mm)
AJm30S	1"	1"	337	180	181.5	78	140	181.5
AJm45S			337	180	181.5	78	140	181.5
AJm60S			376	200	214	88.5	140	214
AJm75S			376	200	214	88.5	140	214
AJm90S			376	200	214	88.5	140	214

### Hydraulic Performance Curves

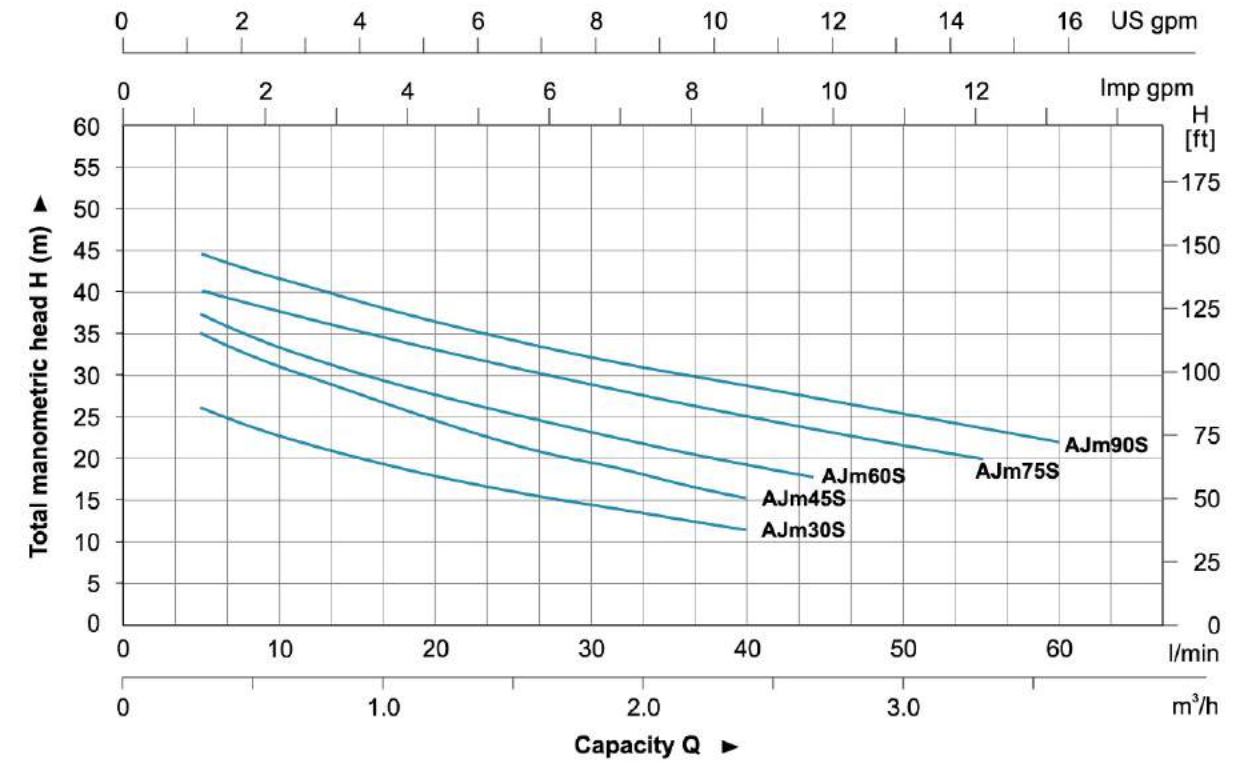

### Materials Table

No.	Part	Material
1	Pump body	AISI 304
2	Venturi tube	PPO
3	Diffuser	PPO
4	Impeller	AISI 304
5	O-ring	NBR
6	Mechanical seal	Carbon/Ceramic
7	Bracket cover	AISI 304
8	Support	ZL102
9	Rotor	
10	Bearing	
11	Stator	
12	Terminal board	PC
13	Terminal box	PAG-GF25
14	Capacitor	
15	Rear cover	ZL102
16	Fan	PP
17	Fan cover	PP

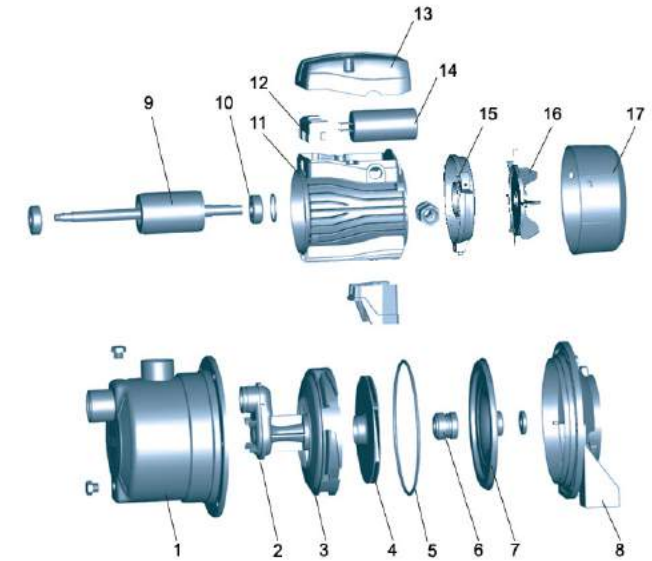

### Package Information

Model	GW (Kgs)	L (mm)	W (mm)	H (mm)	Quantity (PCS/20 TEU)
AJm30S	6.0	350	180	220	1920
AJm45S	6.9	350	180	220	1920
AJm60S	9.2	420	228	257	1056
AJm75S	10.1	420	228	257	1056
AJm90S	10.7	420	228	257	1056







### Application

- Can be used to transfer clean water or other liquids similar to water in physical and chemical properties
- Suitable for lifting water from the well, sprinkling irrigation in garden, pressure boosting of running water, and supporting equipment etc.

### Pump

- Cast iron pump body and support under special anti-rust treatment
- Stainless steel impeller
- AISI 304 shaft
- Max. liquid temperature: +60°C
- Max. suction: +9 m

### Motor

- C&U bearing
- Motor with copper winding
- Built-in thermal protector for single phase motor
- Insulation class: F
- Protection class: IPX4
- Max. ambient temperature: +40°C

### Identification Codes

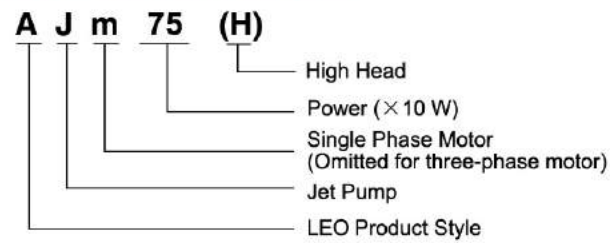

### Technical Data

MODEL	POWER		Q (m³/h)	H (m)																											
	kW	HP		0	0.3	0.6	0.9	1.2	1.5	1.8	2.1	2.4	2.8	3.0	3.3	3.6	3.9														
AJm30	0.3	0.4	0	5	10	15	20	25	30	35	40	47	50	55	60	65	35	30	26	22.5	20	18	16	14	-	-	-	-	-	-	
AJm45	0.45	0.6	0	5	10	15	20	25	30	35	40	47	50	55	60	65	41	36	32	28	25	22	20	18	-	-	-	-	-	-	-
AJm60	0.6	0.8	0	5	10	15	20	25	30	35	40	47	50	55	60	65	45	41	37	33.5	31	28.5	26	24	22.5	21	-	-	-	-	-
AJm75	0.75	1.0	0	5	10	15	20	25	30	35	40	47	50	55	60	65	40	38	36	34.5	33	31.5	30	29	28	27	26	25	24	23	-
AJm75H	0.75	1.0	0	5	10	15	20	25	30	35	40	47	50	55	60	65	51	47	43	40	37	34.5	32	30	27.5	25	-	-	-	-	-
AJm90	0.9	1.2	0	5	10	15	20	25	30	35	40	47	50	55	60	65	48	46	44	42.5	41	39.5	38	36	35	34	33	32	31	30	-
AJm90H	0.9	1.2	0	5	10	15	20	25	30	35	40	47	50	55	60	65	62	57	53	49	46	43	40	37	35	33	-	-	-	-	-

### Hydraulic Performance Curves

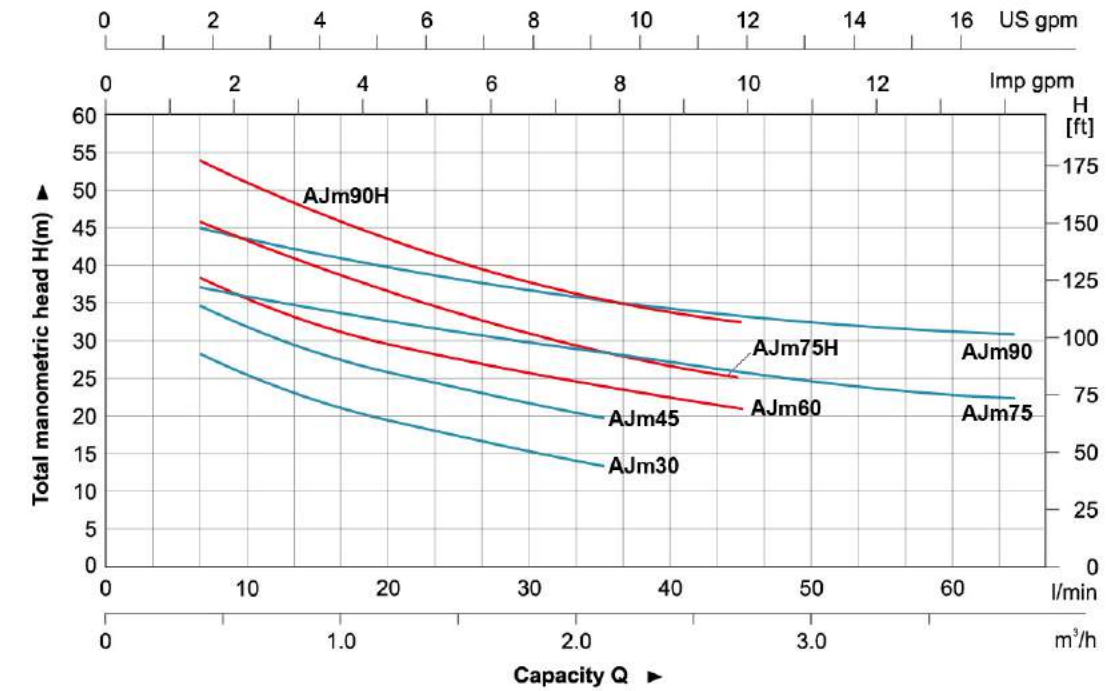

### Materials Table

No.	Part	Material
1	Pump body	HT 200
2	Venturi tube	PPO
3	Diffuser	PPO
4	Impeller	AISI 304
5	Mechanical seal	Carbon/Ceramic
6	C-ring	NBR
7	Support cover	AISI 304
8	Support	ZL 102
9	Bearing	
10	Rotor	
11	Fan cover	PP
12	Fan	PP
13	Rear cover	ZL 102
14	Capacitor	
15	Terminal box	PA6-GF25
16	Terminal board	
17	Stator	

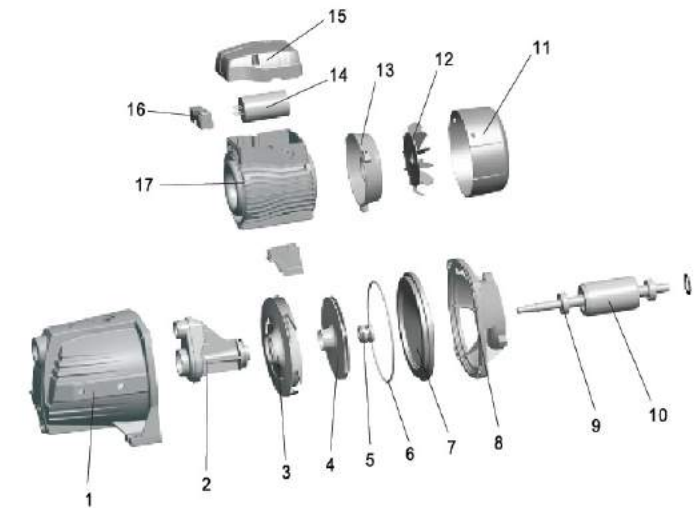

### Package Information

Model	GW (Kgs)	L (mm)	W (mm)	H (mm)	Quantity (PCS/20 TEU)
AJm30	9.2	390	185	215	1740
AJm45	10.15	390	185	215	1740
AJm60	14.35	455	215	245	1170
AJm75	15.5	455	215	245	1170
AJm75H	15.5	450	215	245	1170
AJm90	16.45	455	215	245	1170
AJm90H	16.45	450	215	245	1170



### Dimension

Model	DN1	DN2	A (mm)	B (mm)	C (mm)	D (mm)	E (mm)	F (mm)	G (mm)
AJm30	1"	1"	358	160	105	180	89.5	90	10
AJm45	1"	1"	358	160	105	180	89.5	90	10
AJm60	1"	1"	418	190	150	212	113	100	10
AJm75	1"	1"	418	190	150	212	113	100	10
AJm75H	1"	1"	418	190	150	212	113	100	10
AJm90	1"	1"	418	190	150	212	113	100	10
AJm90H	1"	1"	418	190	150	212	113	100	10

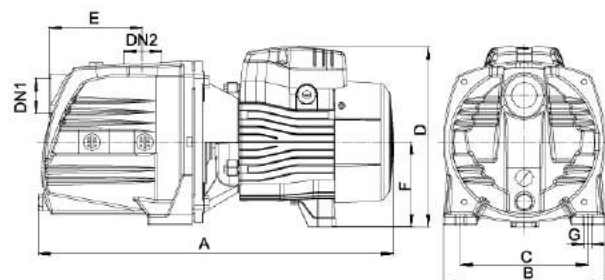





### Application

- Can be used to transfer clean water or other liquids similar to water in physical and chemical properties
- Suitable for lifting water from the well, sprinkling irrigation in garden, pressure boosting of running water, and supporting equipment etc.

### Pump

- Cast iron pump body and support under special anti-rust treatment
- Stainless steel impeller
- AISI 304 shaft
- Max. liquid temperature: +60°C
- Max. suction: +9 m

### Motor

- C&U bearing
- Motor with copper winding
- Built-in thermal protector for single phase motor
- Insulation class: F
- Protection class: IPX4
- Max. ambient temperature: +40°C

### Identification Codes

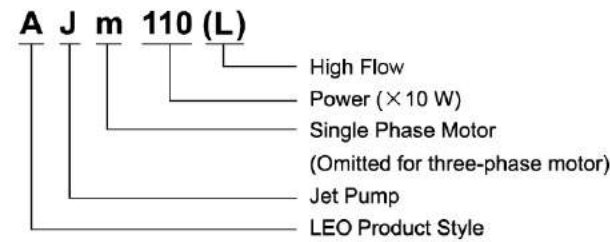

### Technical Data

MODEL	POWER		Q (m³/h)																
	kW	HP	0	0.6	0.9	1.2	1.5	1.8	2.1	2.4	2.7	3.0	3.6	4.2	4.8	6.0	7.2	8.4	9.6
AJm110H	1.1	1.5	60	55	55	49	49	46	44	40	39.5	38	36	30	-	-	-	-	-
AJm150H	1.5	2.2	72	66	61	59	54	52	49.5	49	45	42	42	33	-	-	-	-	-
AJ(m)220H	2.2	3	85	78	78	72	73	70	67	61	61	59	53	42	-	-	-	-	-
AJm110	1.1	1.5	55	50	48	47	45	44	42.5	40	39	38	35	31.5	31	23	-	-	-
AJm150	1.5	2.2	60	55	56	53	52	51	49	45	46	45	39	38	33	-	-	-	-
AJ220	2.2	3	88	64	65.5	61	63	61.5	60	55	57	56	51	51	46	41	35	-	-
AJm110L	1.1	1.5	47	45	45	43	42	41	40	38	37.5	36.5	34	31	30	22	21	17	-
AJm150L	1.5	2.2	54	52	46	49	44	43	42	45	40	39	38	35	32	29	24	24	-
AJ220L	2.2	3	55	53	49.5	52	48	47.5	46.5	49	45	44	46	41	43	40	34	26	30

### Dimension

Model	DN1	DN2	L (mm)	W (mm)	H (mm)	L <sub>1</sub> (mm)	W <sub>1</sub> (mm)	H <sub>1</sub> (mm)
AJm110	1 1/4"	1"	512	206	236	153	178	112
AJm110H			512	206	236	153	178	112
AJm110L			512	206	236	153	178	112
AJm150			512	206	236	153	178	112
AJm150H			512	206	236	153	178	112
AJm150L	512	206	236	153	178	112		
AJ220	1 1/2"	1 1/2"	512	206	236	153	178	112
AJ(m)220H			512	206	236	153	178	112
AJ220L			512	206	236	153	178	112

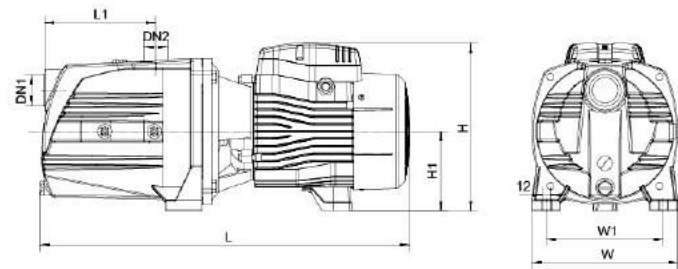

### Hydraulic Performance Curves

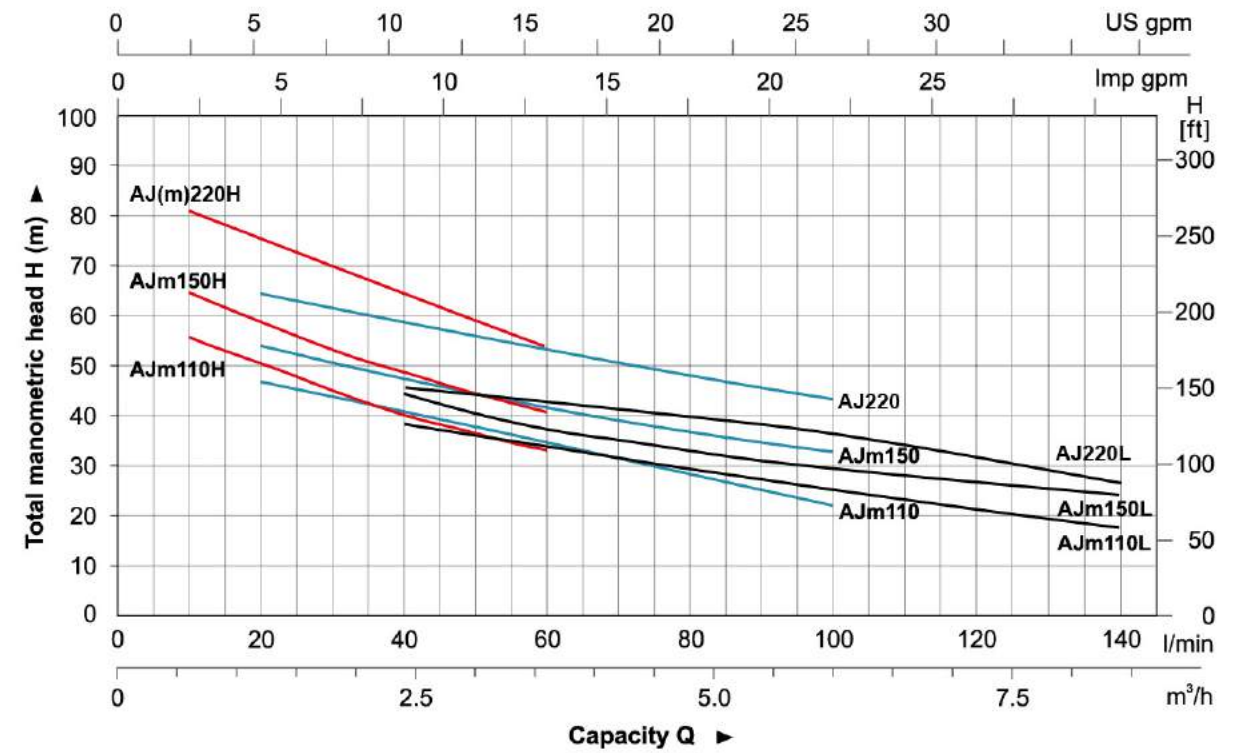

### Materials Table

No.	Pnrt	Material
1	Pump body	HT200
2	Nozzle	PPO
3	O-ring	NBR
4	Venturi tube	PPO
5	Diffuser	PPO
6	Mechanical seal	Carbon/Ceramic
7	Impeller	AISI 304
8	Support cover	HT200
9	Support	ZL102
10	Bearing	
11	Rotor	
12	Stator	
13	Terminal board	PC
14	Terminal box	PA6-GF25
15	Capacitor	
16	Rear cover	ZL102
17	Fan	PP
18	Fan cover	PP

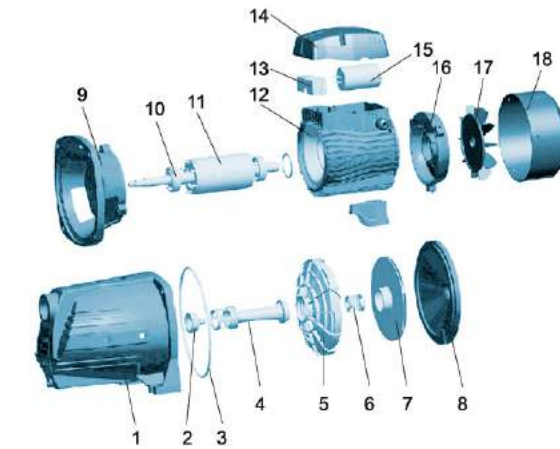

### Package Information

Model	GW (Kgs)	L (mm)	W (mm)	H (mm)	Quantity (PCS/20 TEU)
AJm110	24.5	572	225	259	816
AJm110H	24.5	572	225	259	816
AJm110L	24.5	572	225	259	816
AJm150	25.4	572	225	259	816
AJm150H	25.4	572	225	259	816
AJm150L	25.4	572	225	259	816
AJ220	26.0	572	225	259	816
AJ(m)220H	26.0	572	225	259	816
AJ220L	26.0	572	225	259	816







## Application

- Can be used to transfer clean water or other liquids similar to water in physical and chemical properties
- Suitable for lifting water from the well, sprinkling irrigation in garden, pressure boosting of running water, and supporting equipment etc.

## Pump

- Cast iron pump body and support under special anti-rust treatment
- Stainless steel impeller
- AISI 304 shaft
- Max. liquid temperature: +60°C
- Max. suction: +40 m

## Motor

- C&U bearing
- Motor with copper winding
- Built-in thermal protector for single phase motor
- Insulation class: F
- Protection class: IPX4
- Max. ambient temperature: +40°C

## Identification Code

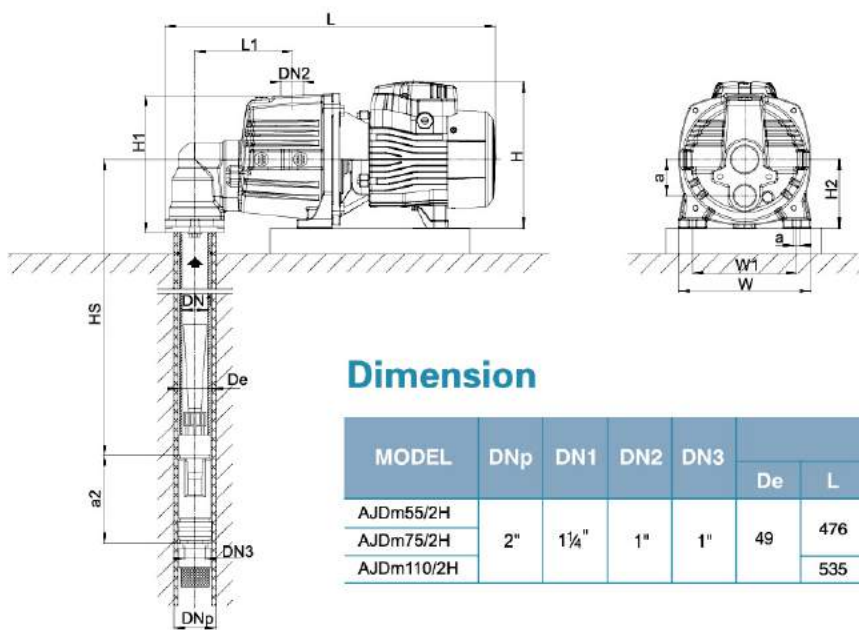
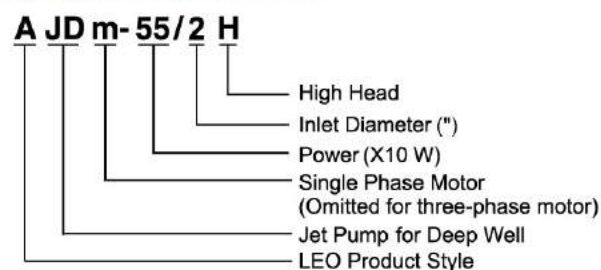

## Dimension

MODEL	DNp	DN1	DN2	DN3	DIMENSIONS (mm)										
					De	L	H	W	L1	H1	H2	W1	a	a2	S
AJDm55/2H					49	476	212	190	140	204	110	150	53	128	10
AJDm75/2H	2"	1 1/4"	1"	1"											
AJDm110/2H						535	237	206	153	211	112	166			

## Technical Data

MODEL	POWER (kW) (HP)	HS (m)	Q (l/min)	H (m)																				
				0	2	4	6	8	10	12	14	16	18	20	22	24	26	28	30					
AJDm55/2H	0.55	0.75	15	37	33	30	27	25	23	21	19	17	15	13	-	-	-	-	-					
AJDm75/2H	0.75	1		47	43	40	37	34	31	29	27	25	23	21	19	17	-	-	-	-				
AJDm110/2H	1.1	1.5		70	65	61	57	53	50	47	44	42	40	38	36	34	32	30	28	-				
AJDm55/2H	0.55	0.75		20	30	26	23	21	19	17	15	13	-	-	-	-	-	-	-	-				
AJDm75/2H	0.75	1			39	36	33	30	27	24	22	20	18	17	-	-	-	-	-	-	-			
AJDm110/2H	1.1	1.5			62	57	53	49	46	43	40	38	36	34	32	28	28	-	-	-	-			
AJDm55/2H	0.55	0.75			25	23	19	16	14	12	-	-	-	-	-	-	-	-	-	-	-			
AJDm75/2H	0.75	1				32	29	26	23	20	18	16	-	-	-	-	-	-	-	-	-	-		
AJDm110/2H	1.1	1.5				54	49	45	42	39	36	33	31	29	27	-	-	-	-	-	-	-		
AJDm55/2H	0.55	0.75				30	16	13	-	-	-	-	-	-	-	-	-	-	-	-	-	-		
AJDm75/2H	0.75	1					25	22	19	16	-	-	-	-	-	-	-	-	-	-	-	-	-	
AJDm110/2H	1.1	1.5					46	42	38	35	32	29	27	-	-	-	-	-	-	-	-	-	-	
AJDm55/2H	0.75	1					35	18	15	-	-	-	-	-	-	-	-	-	-	-	-	-	-	
AJDm75/2H	1.1	1.5						39	35	31	28	-	-	-	-	-	-	-	-	-	-	-	-	-
AJDm110/2H	1.1	1.5						32	28	-	-	-	-	-	-	-	-	-	-	-	-	-	-	-

## Materials Table

No.	Part	Material	No.	Part	Material
1	Elbow	HT200	14	Ejector	HT200
2	Gasket seal	NBR	15	Sealing cup	NBR
3	Pump body	HT200	16	Copper sheathing	HPb59-1
4	Diffuser	PPO	17	Copper sleeve	HPb59-1
5	Impeller	AISI 304	18	Terminal box	PA6-GF25
6	Mechanical seal	Carbon/Ceramic	19	Terminal board	PC
7	O-ring	NBR	20	Stator	
8	Support cover	AISI 304/HT200	21	Motor foot	PA6
9	Support	ZL102	22	Capacitor	
10	Bearing		23	Cable holder	
11	Rotor		24	Rear cover	ZL102
12	Venturi tube	PPO	25	Fan	PP
13	Nozzle	PPO	26	Fan cover	PP

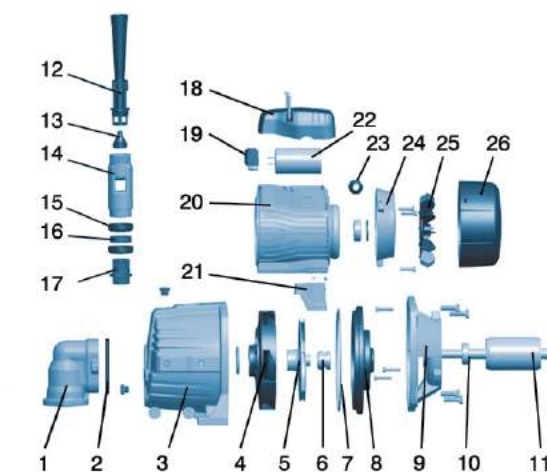

## Package Information

MODEL	WG (kgs)	L (mm)	W (mm)	H (mm)	Quantity (PCS/20 TEU)
AJDm55/2H	15.65	500	215	240	1053
AJDm75/2H	16.9	500	215	240	1053
AJDm110/2H	21.95	585	230	265	728







## Application

- Can be used to transfer clean water or other liquids similar to water in physical and chemical properties
- Suitable for lifting water from the well, sprinkling irrigation in garden, pressure boosting of running water, and supporting equipment etc.

## Pump

- Cast iron pump body and support under special anti-rust treatment
- Stainless steel impeller
- AISI 304 shaft
- Max. liquid temperature: +60°C
- Max. suction: +40 m

## Motor

- C&U bearing
- Motor with copper winding
- Built-in thermal protector for single phase motor
- Insulation class: F
- Protection class: IPX4
- Max. ambient temperature: +40°C

## Identification Code

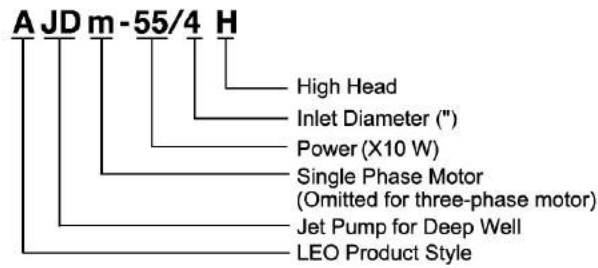

## Technical Data

MODEL	POWER		HS (m)	Q (l/min)	H (m)																	
	(kW)	(HP)			0	2	4	6	8	10	12	14	16	18	20	22	24	26	28	30	32	34
AJDm55/4H	0.55	0.75	15	15	39	35	33	29	27	25	23	21	19	17	15	14	13	-	-	-	-	-
AJDm75/4H	0.75	1			50	46	43	40	37	34	32	30	28	26	24	22	20	19	18	17	-	-
AJDm110/4H	1.1	1.5			75	70	66	62	58	55	52	49	47	45	43	41	39	37	35	33	31	29
AJDm55/4H	0.55	0.75	20	20	32	28	25	23	21	19	17	15	13	-	-	-	-	-	-	-	-	-
AJDm75/4H	0.75	1			42	39	36	33	30	27	25	23	21	20	18	17	-	-	-	-	-	-
AJDm110/4H	1.1	1.5			67	62	58	54	51	48	45	43	41	39	37	35	33	31	29	27	-	-
AJDm55/4H	0.55	0.75	25	25	25	21	18	16	14	12	-	-	-	-	-	-	-	-	-	-	-	-
AJDm75/4H	0.75	1			35	32	29	26	23	21	19	17	-	-	-	-	-	-	-	-	-	-
AJDm110/4H	1.1	1.5			59	54	50	47	44	41	38	36	34	32	30	28	-	-	-	-	-	-
AJDm55/4H	0.55	0.75	30	30	18	15	12	-	-	-	-	-	-	-	-	-	-	-	-	-	-	-
AJDm75/4H	0.75	1			28	25	22	19	17	-	-	-	-	-	-	-	-	-	-	-	-	-
AJDm110/4H	1.1	1.5			51	47	43	40	37	34	32	30	28	-	-	-	-	-	-	-	-	-
AJDm75/4H	0.75	1	35	35	21	18	16	-	-	-	-	-	-	-	-	-	-	-	-	-	-	-
AJDm110/4H	1.1	1.5			44	40	36	33	30	27	-	-	-	-	-	-	-	-	-	-	-	-
AJDm110/4H	1.1	1.5			37	33	30	27	-	-	-	-	-	-	-	-	-	-	-	-	-	-

## Materials Table

No.	Part	Material	No.	Part	Material
1	Pump body	HT200	12	Ejector	HT200
2	Diffuser	PPO	13	Terminal box	PA6-GF25
3	Impeller	Stainless steel	14	Terminal board	PC
4	Mechanical seal	Carbon/Ceramic	15	Stator	
5	O-ring	NBR	16	Motor foot	PA6
6	Support cover	AISI 304/HT200	17	Capacitor	
7	Support	ZL102	18	Cable holder	
8	Bearing		19	Rear cover	ZL102
9	Rotor		20	Fan	PP
10	Venturi tube	PPO	21	Fan cover	PP
11	Nozzle	PPO			

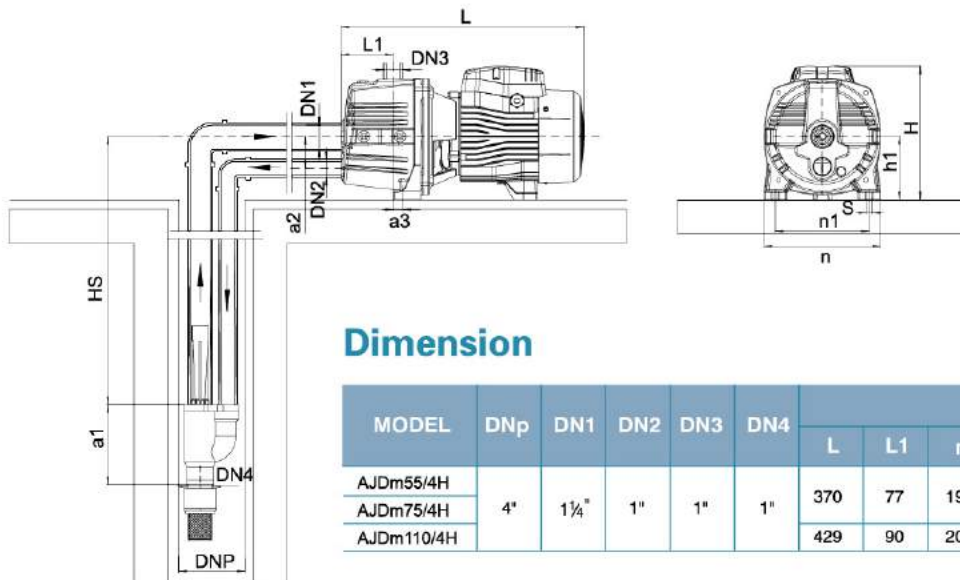
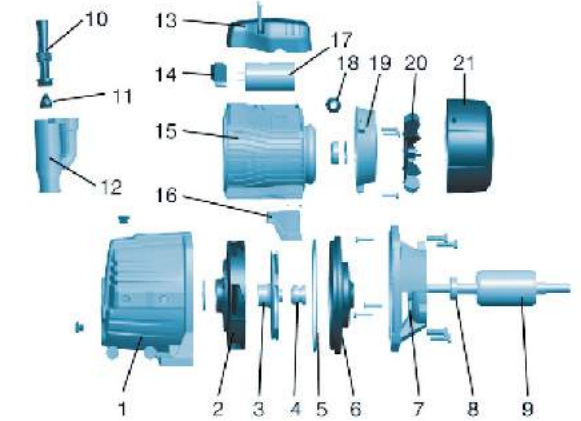

## Dimension

MODEL	DNp	DN1	DN2	DN3	DN4	DIMENSIONS (mm)									
						L	L1	n	n1	H	h1	a1	a2	a3	S
AJDm55/4H						370	77	190	150	212	100	160	53	17	10
AJDm75/4H	4"	1 1/4"	1"	1"	1"	429	90	206	166	236	112	160	53	12	10
AJDm110/4H															

## Package Information

MODEL	WG (kgs)	L (mm)	W (mm)	H (mm)	Quantity (PCS/20 TEU)
AJDm55/4H	16.65	500	215	240	1053
AJDm75/4H	17.9	500	215	240	1053
AJDm110/4H	23.25	585	230	265	728







### Application

- Can be used to transfer clean water or other liquids similar to water in physical and chemical properties
- Suitable for industrial use and urban water supply, pressure boosting for high buildings and fire fighting, garden irrigation, long-distance water transfer, heating ventilation and air controlling, circulation and pressure boosting for cold and hot water, and supporting equipment etc.

### Pump

- Cast iron pump body and support under special anti-rust treatment
- AISI 304 shaft
- Max. liquid temperature: +60°C
- Max. suction: +8 m

### Motor

- C&U bearing
- Motor with copper winding
- Built-in thermal protector for single phase motor
- Insulation class: F
- Protection class: IPX4
- Max. ambient temperature: +40°C
- IE 2 motor (Three phase, power ≥ 0.75kW)

### Identification Codes

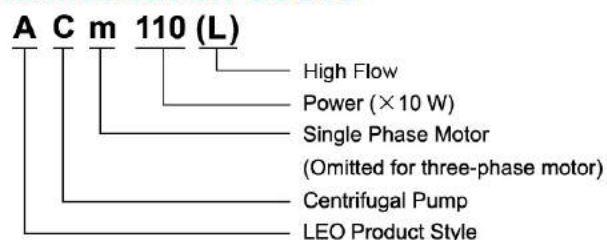

### Technical Data

MODEL	POWER	Q (m <sup>3</sup> /h)																					
		0	0.6	0.9	1.2	1.8	2.4	3.0	3.6	4.2	4.5	4.8	5.4	6.0	6.6	7.2	7.8	8.4	9.0	9.6	10.8	11.7	12.6
Single Phase	Three Phase																						
ACm25	—	0.25	0.3																				
ACm37	—	0.37	0.5																				
ACm60	AC60	0.6	0.8																				
ACm75	AC75	0.75	1.0																				
ACm110	AC110	1.1	1.5																				
ACm150	AC150	1.5	2																				
—	AC220	2.2	3																				
ACm110L	AC110L	1.1	1.5																				
ACm150L	AC150L	1.5	2																				

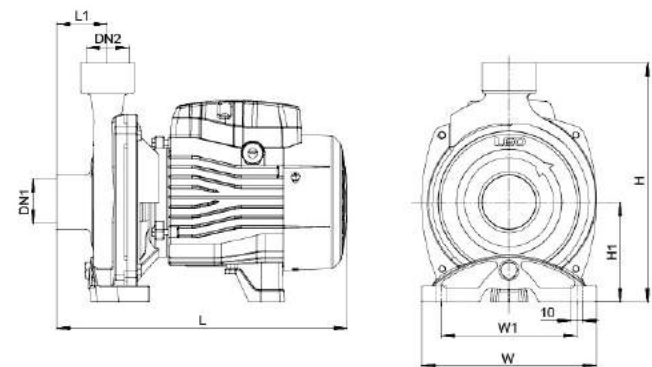

### Dimension

Model	DN1	DN2	L (mm)	W (mm)	H (mm)	L <sub>1</sub> (mm)	W <sub>1</sub> (mm)	H <sub>1</sub> (mm)
ACm25	1"	1"	270	157	216	42	122	90
ACm37			270	157	216	42	122	90
ACm60			298	190	240	44	160	90
ACm75	1 1/4"	1"	298	190	240	44	160	100
ACm110			359	206	263	50	178	112
ACm150			360	240	286	51	207	115
AC 220	1 1/2"	1"	360	240	286	51	207	115
ACm110L			356	206	265	48.5	178	112
ACm150L			356	206	265	48.5	178	112

### Hydraulic Performance Curves

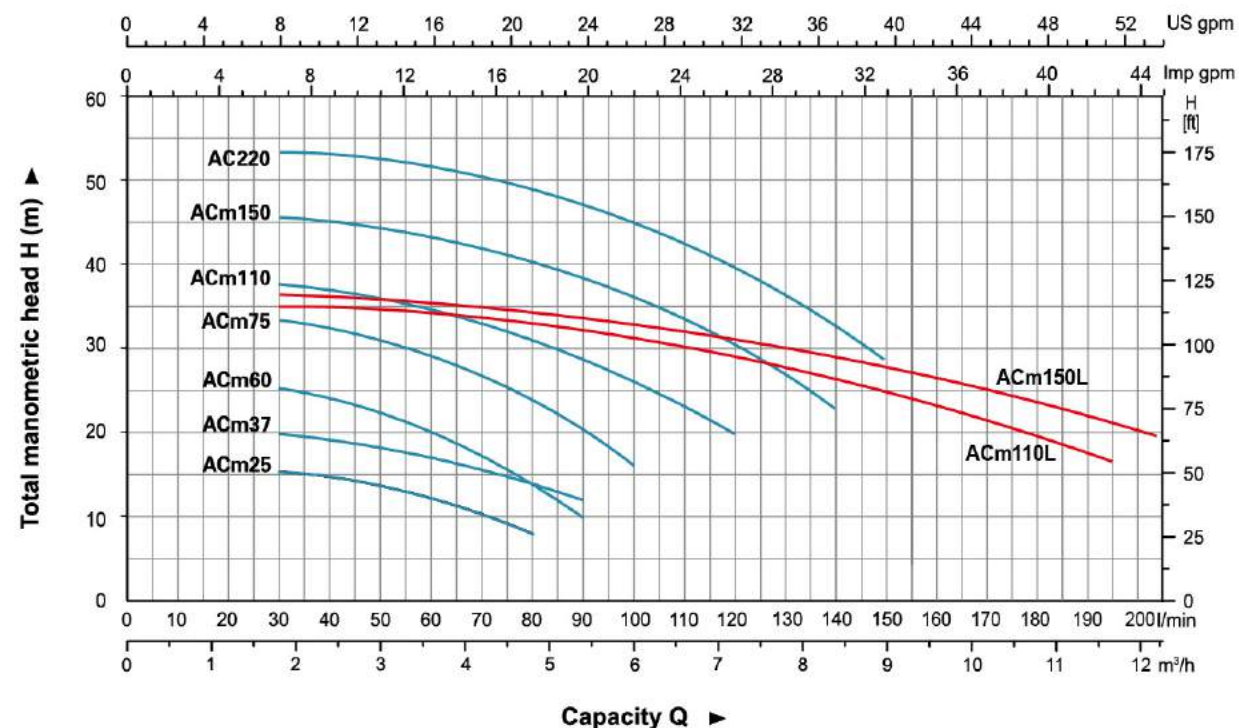

### Materials Table

No.	Part	Material
1	Pump body	HT200
2	Impeller	AISI 304 Brass
3	O-ring	NBR
4	Mechanical seal	Carbon/Ceramic
5	Support cover	AISI 304/HT200
6	Support	ZL102
7	Terminal board	PC
8	Stator	
9	Terminal box	PA6-GF25
10	Capacitor	
11	Rotor	
12	Bearing	
13	Rear cover	ZL102
14	Fan	PP
15	Fan cover	PP

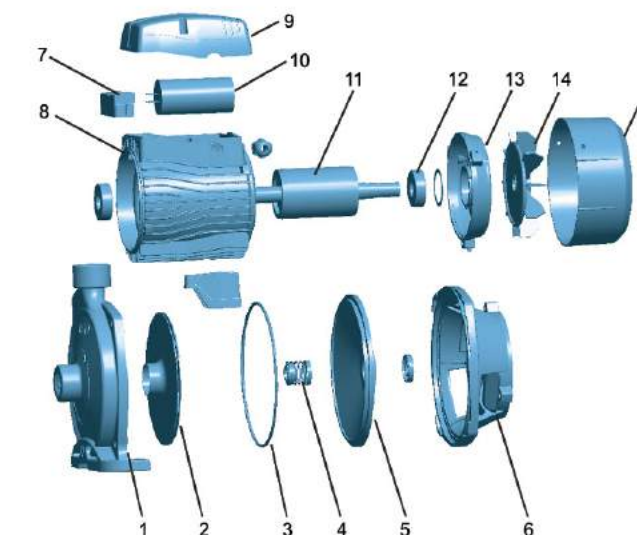

### Package Information

Model	GW (Kgs)	L (mm)	W (mm)	H (mm)	Quantity (PCS/20 TEU)
ACm25	7.9	290	185	239	2124
ACm37	8.4	290	185	239	2124
ACm60	11.5	333	215	260	1384
ACm75	13.4	333	215	260	1384
ACm110	18.45	383	233	287	987
ACm150	22.8	425	265	310	770
AC220	23.3	425	265	310	770
ACm110L	18.4	383	233	287	987
ACm150L	19.35	383	233	287	987







### Application

- Can be used to transfer clean water or other liquids similar to water in physical and chemical properties
- Suitable for industrial use and urban water supply, pressure boosting for high buildings and fire fighting, garden irrigation, long-distance water transfer, heating ventilation and air controlling, circulation and pressure boosting for cold and hot water, and supporting equipment etc.

### Pump

- Cast iron pump body and support under special anti-rust treatment
- AISI 304 shaft
- Max. liquid temperature: +60°C
- Max. suction: +8 m

### Motor

- C&U bearing
- Motor with copper winding
- Insulation class: F
- Protection class: IPX4
- Max. ambient temperature: +40°C
- IE 2 motor (Three phase, power ≥ 0.75kW, AC750C2 and AC750C4 excluded)

### Identification Codes

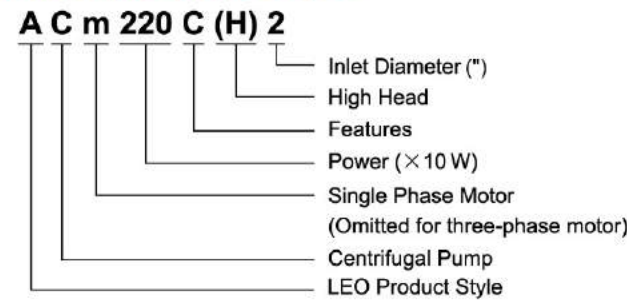

### Technical Data

MODEL		POWER		Q (m³/h)														
Single Phase	Three Phase	kW	HP	0	6	9	12	15	18	24	27	30	36	42	48	54		
				Q (l/min)	0	100	150	200	250	300	400	450	500	600	700	800	900	
ACm220CH2	AC220CH2	2.2	3	H (m)	31	30	29.5	28.5	27.5	26	21.5	18.5	-	-	-	-	-	
ACm300CH2	AC300CH2	3	4		38	37.5	37	36	34.5	33	28.5	25.5	-	-	-	-	-	-
ACm400CH2	AC400CH2	4	5.5		49	48	47	46	45	43.5	39.5	37	-	-	-	-	-	-
---	AC550CH2	5.5	7.5		54	52.5	52	51	50	49	46	44	42	-	-	-	-	-
ACm300C2	AC300C2	3	4		30	29.5	29	28.5	28	27	25	23.5	22	19.5	15.5	11.5	-	-
ACm400C2	AC400C2	4	5		39	38.5	38	37.5	37	36	34	32.5	31	28	24	18.5	13	-
---	AC550C2	5.5	7.5		46.5	45.5	45	44.5	43.5	42.5	40	38.5	37	33	28	22	15	-
---	AC750C2	7.5	10		56.5	55	55	54.5	53.5	52.5	50	48.5	46.5	42	36.5	30.5	20	-
---	AC750C4	7.5	10		52.5	52	52	51.5	51	50.5	48	46.5	44.5	40	35.5	30.5	24	-

### Dimension

Model	DN1	DN2	L (mm)	W (mm)	H (mm)	L <sub>1</sub> (mm)	W <sub>1</sub> (mm)	H <sub>1</sub> (mm)		
ACm220CH2	2"	2"	444	255	315	65	186	132		
ACm300CH2			444	255	315	65	186	132		
ACm400CH2			496.5	280	326	70	195	136		
AC550CH2			496.5	280	326	70	195	136		
ACm300C2			444	255	315	65	186	132		
ACm400C2			496.5	280	326	70	195	136		
AC550C2			496.5	280	326	70	195	136		
AC750C2			515	290	360	85	216	150		
AC750C4			4"	3"	525	290	360	95	216	150

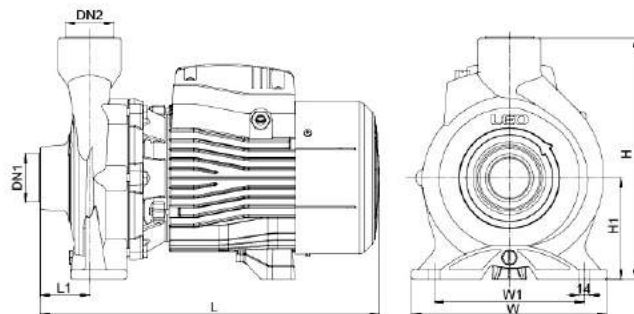

### Hydraulic Performance Curves

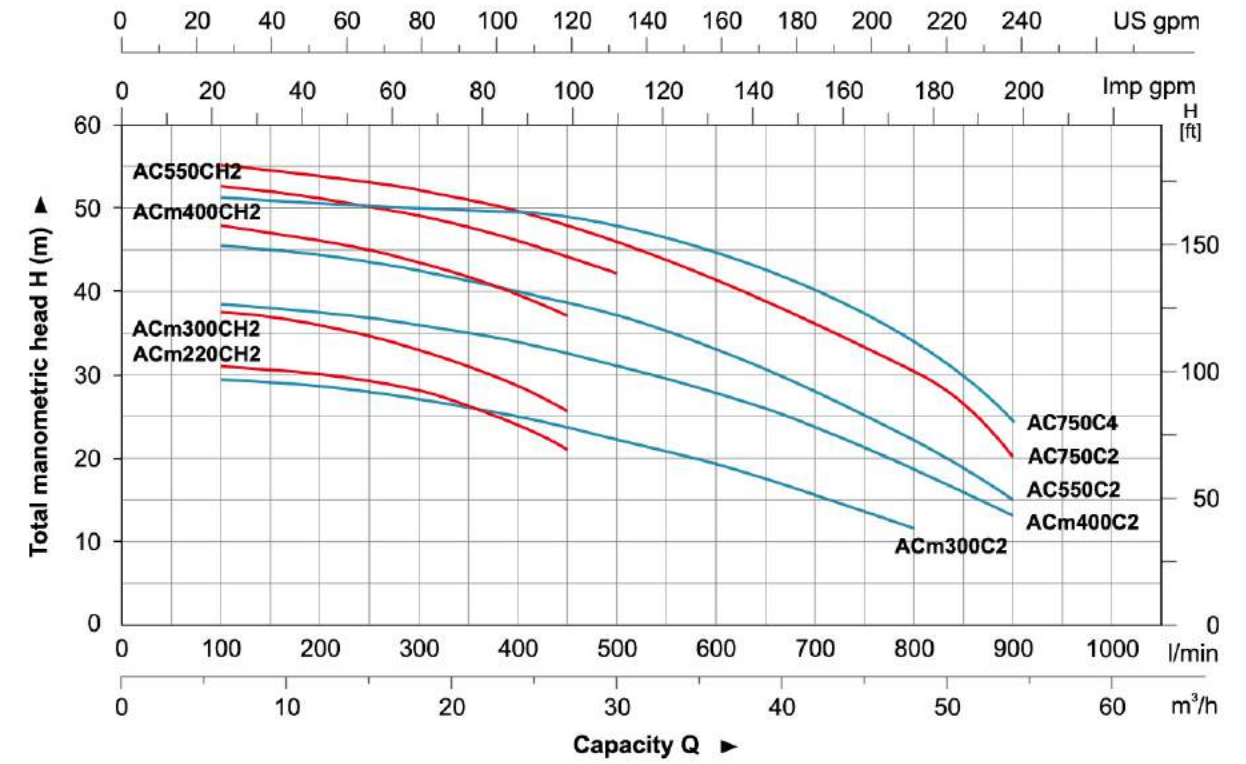

### Materials Table

No.	Part	Material
1	Pump body	HT200
2	Impeller	AISI 304 Brass
3	Mechanical seal	Carbon/Ceramic
4	Bracket cover	HT200
5	Oil seal	
6	Support	HT200
7	Bearing	
8	Rotor	
9	Fan cover	PP
10	Fan	PP
11	Rear cover	ZL102
12	Stator	
13	Capacitor	
14	Terminal box	PA6-GF25

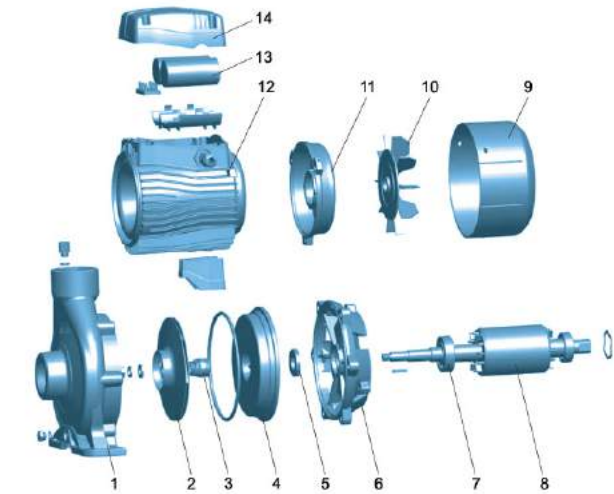

### Package Information

Model	GW (Kgs)	L (mm)	W (mm)	H (mm)	Quantity (PCS/20 TEU)
ACm220CH2	39	507	304	372	486
ACm300CH2	41.8	507	304	372	478
ACm400CH2	56.5	562	328	383	345
AC550CH2	57.1	562	328	383	345
ACm300C2	41.4	507	304	372	483
ACm400C2	57.5	562	328	372	345
AC550C2	55.5	562	328	383	345
AC750C2	62	587	338	417	305
AC750C4	63.7	587	338	417	305







**Application**

- Can be used to transfer clean water or other liquids similar to water in physical and chemical properties
- Suitable for industrial use and urban water supply, pressure boosting for high buildings and fire fighting, garden irrigation, long-distance water transfer, heating ventilation and air controlling, circulation and pressure boosting for cold and hot water, and supporting equipment etc.

**Pump**

- Cast iron pump body and support under special anti-rust treatment
- AISI 304 shaft
- Max. liquid temperature: +60°C
- Max. suction: +8 m

**Motor**

- C&U bearing
- Motor with copper winding
- Built-in thermal protector for single phase motor
- Insulation class: F
- Protection class: IPX4
- Max. ambient temperature: +40°C
- IE 2 motor (Three phase, power ≥ 0.75kW)

**Identification Codes**

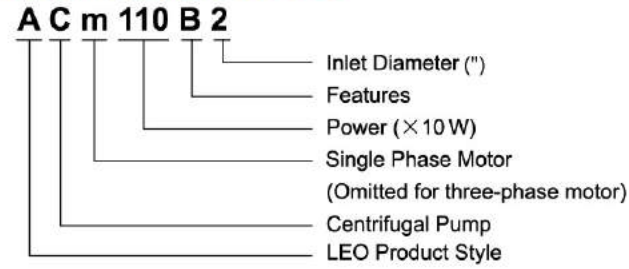

**Technical Data**

MODEL		POWER		Q (m³/h)													
Single Phase	Three Phase	kW	HP	0	6	9	12	15	18	21	24	30					
				Q (l/min)	0	100	150	200	250	300	350	400	500				
ACm60B2	AC60B2	0.6	0.8	H (m)	12.5	12	11.7	11	10.2	9.2	8	6.5	-				
ACm75B2	AC75B2	0.75	1		14	13.7	13.5	13	12.3	11.2	9.9	8.5	5.5				
ACm110B2	AC110B2	1.1	1.5		19.5	19.2	19	18.5	17.7	16.5	15	13	8.5				
ACm150B2	AC150B2	1.5	2		22	21.5	21	20.5	19.5	18.3	16.5	14.5	9.5				
					Q (l/min)	0	100	150	200	250	300	350	400	500			

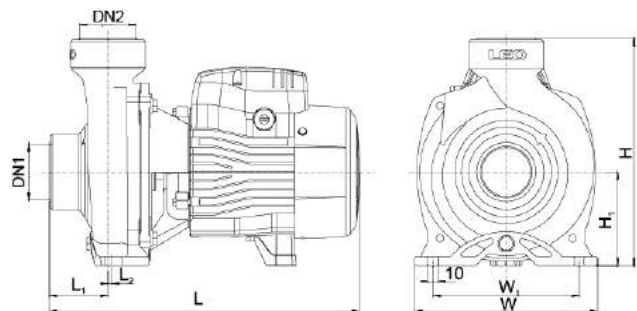

**Dimension**

Model	DN1	DN2	L (mm)	W (mm)	H (mm)	L <sub>1</sub> (mm)	L <sub>2</sub> (mm)	W <sub>1</sub> (mm)	H <sub>1</sub> (mm)
ACm60B2	2"	2"	331	195	242	62.5	4	156	100
ACm75B2	2"	2"	331	195	242	62.5	4	156	100
ACm110B2	2"	2"	378	206	263	59	3.5	166	112
ACm150B2	2"	2"	378	206	263	59	3.5	166	112

**Hydraulic Performance Curves**

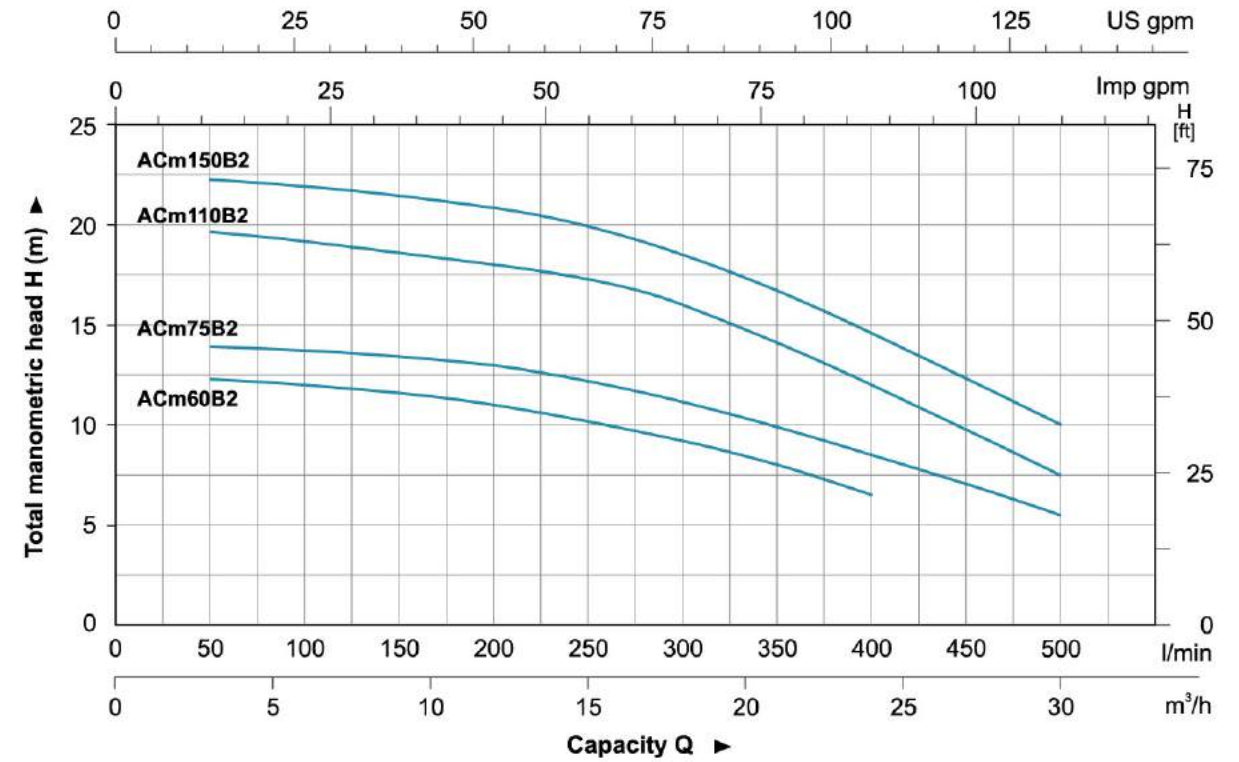

**Materials Table**

No.	Part	Material
1	Pump body	HT200
2	Impeller	AISI 304 Brass
3	Mechanical seal	Carbon/Ceramic
4	Support cover	HT200
5	Oil seal	
6	Support	ZL102
7	Bearing	
8	Rotor	
9	Terminal box	PA6-GF25
10	Stator	
11	Capacitor	
12	Rear cover	ZL102
13	Fan	PP
14	Fan cover	PP

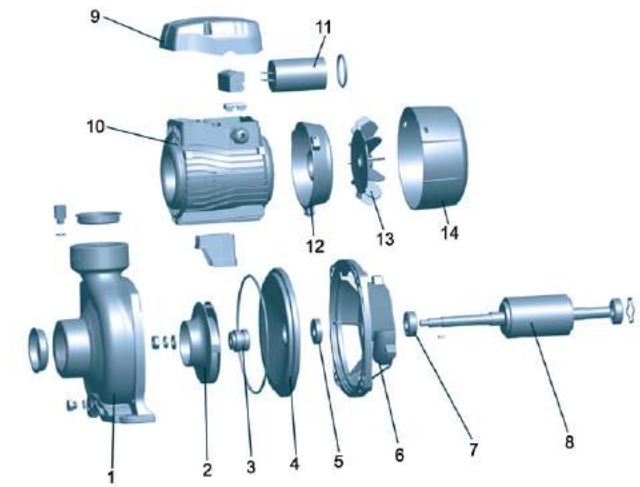

**Package Information**

Model	GW (Kgs)	L (mm)	W (mm)	H (mm)	Quantity (PCS/20' TEU)
ACm60B2	14.4	375	214	265	1264
ACm75B2	15.2	375	214	265	1264
ACm110B2	19.9	415	225	285	945
ACm150B2	20.7	415	225	285	945







### Application

- Can be used to transfer clean water or other liquids similar to water in physical and chemical properties.
- Suitable for industrial use and urban water supply, pressure boosting for high buildings and fire fighting, garden irrigation, long-distance water transfer, heating ventilation and air controlling, circulation and pressure boosting for cold and hot water, and supporting equipment etc.

### Pump

- Cast iron pump body and support under special anti-rust treatment
- AISI304 welding shaft
- Max. liquid temperature: +60°C
- Max.suction: + 8m

### Motor

- C&U bearing
- Motor with copper winding
- Built-in thermal protector
- Insulation class: F
- Protection class: IPX4
- Max. ambient temperature: +40°C
- S1 Duty

### Identification Codes

**A C m 220 B 2**

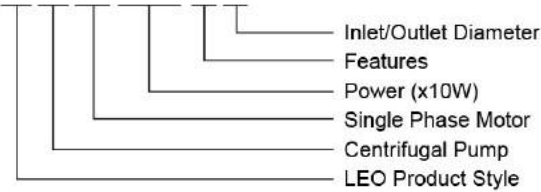

### Technical Data

Model	Power		Q(m <sup>3</sup> /h)	Capacity Q										
	kW	HP		0	6	12	18	19	24	30	36	38.9		
ACm220B2	2.2	3.0	H(m)	23.9	23.8	22.7	21.1	20.9	18.6	15.2	10.1	8.2		
			Q(l/min)	0	100	200	300	316.7	400	500	600	648.3		

### Dimension

Model	DN1	DN2	L (mm)	W (mm)	H (mm)	W1 (mm)	H1 (mm)
ACm220B2	2"	2"	380	206	270	122	121

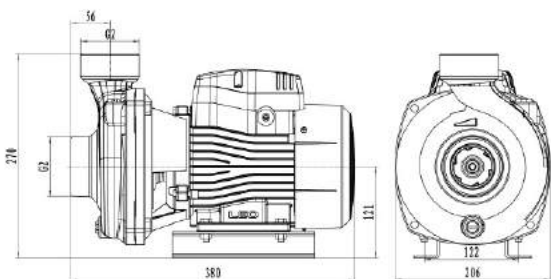

### Hydraulic Performance Curves

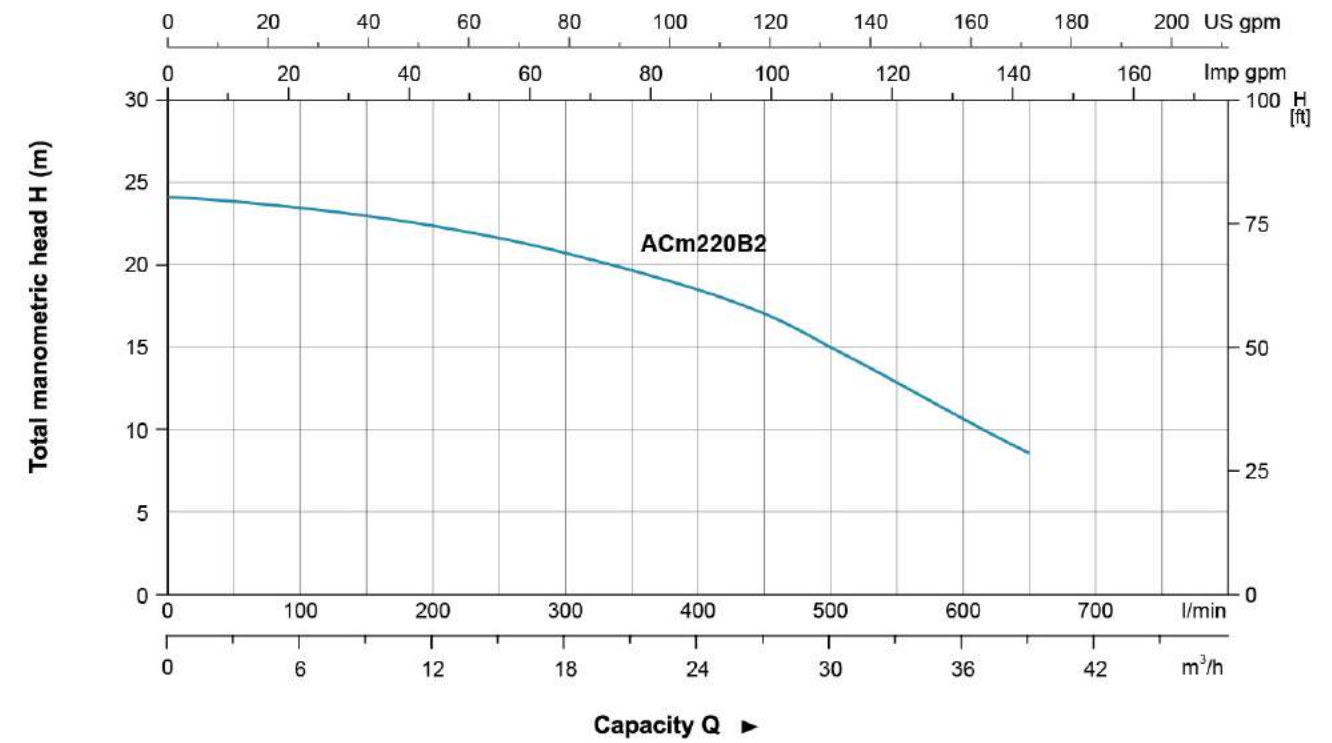

### Materials Table

No.	Part	Material	No.	Part	Material
1	Filling plug	Copper	13	Base	85Mn
2	Pump body	HT200	14	Stator	
3	Impeller	Brass	15	Terminal board	PC+ABS
4	Mechanical seal	Carbon/Ceramic	16	Screw	
5	Support Cover	HT200	17	Terminal box	PA6-GF25
6	Water proof ring		18	Capacitor	
7	Support	ZL102	19	Pressure clamp	PC+ABS
8	Bearing		20	Cable Holder	
9	Rotor				
10	Fan cover	PP			
11	Fan	PP			
12	Rear cover	ZL102			

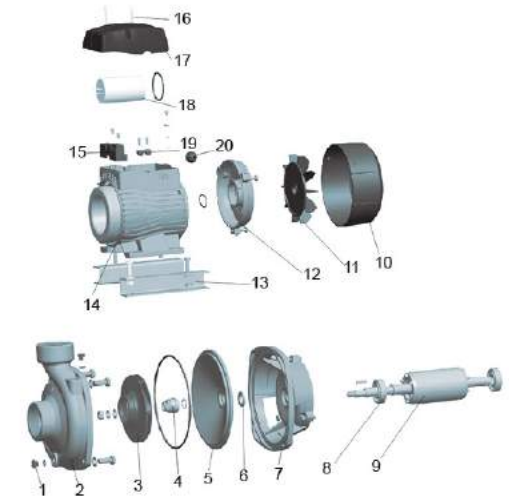

### Package Information

Model	GW (kg)	L (mm)	W (mm)	H (mm)	Quantity (PCS/20 TEU)
ACm220B2	23	416	248	286	819







### Application

- Can be used to transfer clean water or other liquids similar to water in physical and chemical properties
- Suitable for industrial use and urban water supply, pressure boosting for high buildings and fire fighting, garden irrigation, long-distance water transfer, heating ventilation and air controlling, circulation and pressure boosting for cold and hot water, and supporting equipment etc.

### Pump

- Cast iron pump body and support under special anti-rust treatment
- AISI 304 shaft
- Max. liquid temperature: +60°C
- Max. suction: +8 m

### Motor

- C&U bearing
- Motor with copper winding
- Built-in thermal protector for single phase motor (≤1.5 kW)
- Insulation class: F
- Protection class: IPX4
- Max. ambient temperature: +40°C
- IE 2 motor (Three phase, power ≥ 0.75kW)

### Identification Codes

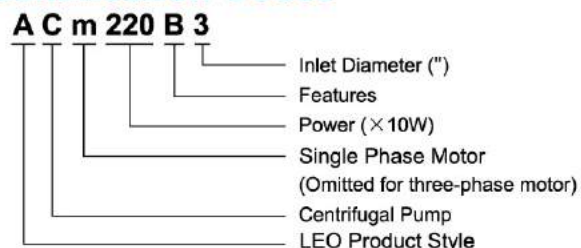

### Technical Data

MODEL		POWER		Q (m³/h)																									
Single Phase	Three Phase	kW	HP	0	12	18	24	30	36	42	48	54	60	66	71	Q (l/min)													
				H (m)																									
ACm110B3	AC110B3	1.1	1.5	12.5	12.5	12.1	11.5	10.5	9.5	8.4	7.1	5.5	-	-	-	0	200	300	400	500	600	700	800	900	1000	1100	1200		
ACm110B4	AC110B4	1.1	1.5	12.5	12.5	12.1	11.5	10.5	9.5	8.4	7.1	5.5	-	-	-	0	200	300	400	500	600	700	800	900	1000	1100	1200		
ACm150B3	AC150B3	1.5	2	14.5	14.3	14	13.5	12.8	12	11.2	9.9	8.4	6	-	-	0	200	300	400	500	600	700	800	900	1000	1100	1200		
ACm150B4	AC150B4	1.5	2	14.5	14.3	14	13.5	12.8	12	11.2	9.9	8.4	6	-	-	0	200	300	400	500	600	700	800	900	1000	1100	1200		
ACm220B3	AC220B3	2.2	3	17.5	17.3	17.1	16.5	16	15.2	14.2	13.2	11.7	10	7.2	-	0	200	300	400	500	600	700	800	900	1000	1100	1200		
ACm220B4	AC220B4	2.2	3	17.5	17.3	17.1	16.5	16	15.2	14.2	13.2	11.7	10	7.2	-	0	200	300	400	500	600	700	800	900	1000	1100	1200		
ACm300B3	AC300B3	3	4	20	19.8	19.6	19.5	19	18.3	17.5	16.2	14.6	13	11.5	10	0	200	300	400	500	600	700	800	900	1000	1100	1200		
ACm300B4	AC300B4	3	4	20	19.8	19.6	19.5	19	18.3	17.5	16.2	14.6	13	11.5	10	0	200	300	400	500	600	700	800	900	1000	1100	1200		

### Dimension

Model	DN1	DN2	L (mm)	W (mm)	H (mm)	L <sub>1</sub> (mm)	W <sub>1</sub> (mm)	H <sub>1</sub> (mm)
ACm110B3	3"	3"	386	230	295	68	180	120
ACm110B4	4"	4"	393	230	295	75	180	120
ACm150B3	3"	3"	386	230	295	68	180	120
ACm150B4	4"	4"	393	230	295	75	180	120
ACm220B3	3"	3"	453	230	295	68	180	120
ACm220B4	4"	4"	460	230	295	75	180	120
ACm300B3	3"	3"	453	230	295	68	180	120
ACm300B4	4"	4"	460	230	295	75	180	120

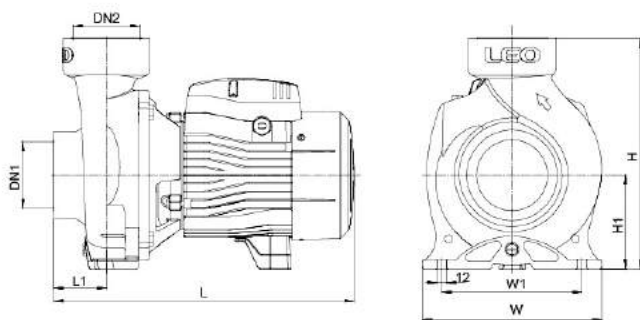

### Hydraulic Performance Curves

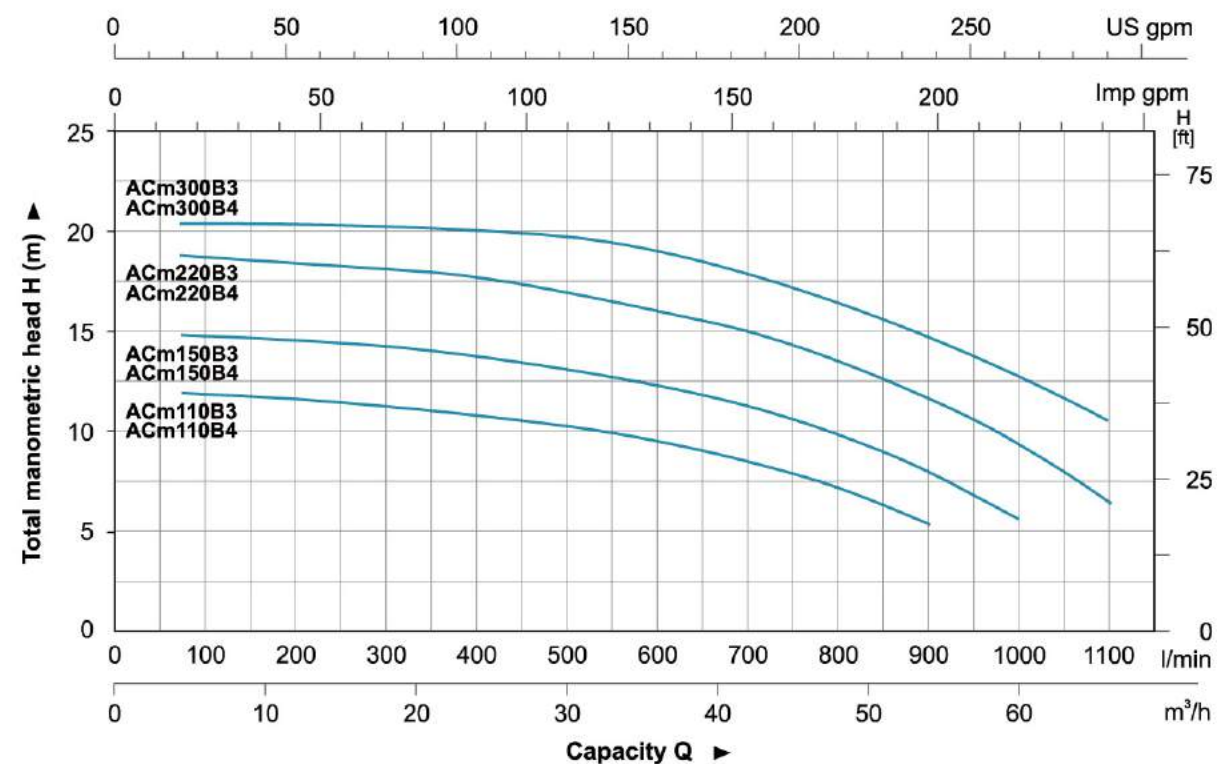

### Materials Table

No.	Part	Material
1	Filling plug	HPb59-1
2	Pump body	HT200
3	Impeller	Brass
4	O-ring	NBR
5	Mechanical seal	Carbon/Ceramic
6	Bracket cover	HT200
7	Oil seal	
8	Support	HT200
9	Bearing	
10	Rotor	
11	Terminal board	PC
12	Capacitor	
13	Terminal box	PA6-GF25
14	Stator	
15	Rear cover	ZL102
16	Fan	PP
17	Fan cover	PP

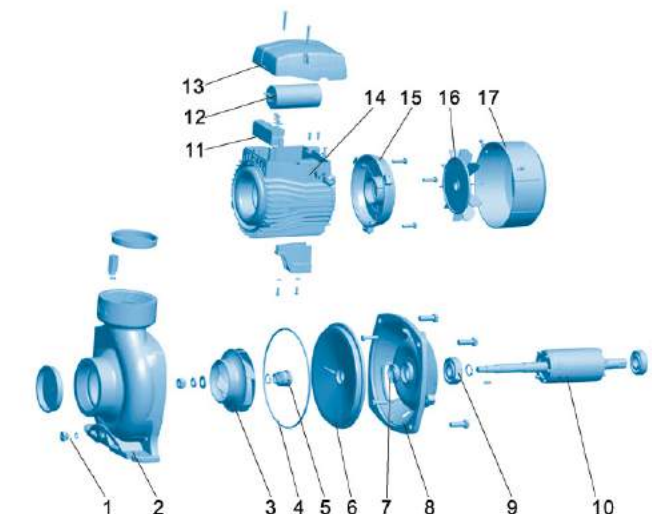

### Package Information

Model	GW (Kgs)	L (mm)	W (mm)	H (mm)	Quantity (PCS/20 TEU)
ACm110B3	26.3	433	255	332	684
ACm110B4	29.5	433	255	332	675
ACm150B3	27.2	433	255	332	684
ACm150B4	30.4	433	255	332	655
ACm220B3	34.8	522	288	331	510
ACm220B4	38	522	288	331	496
ACm300B3	37.3	522	288	331	506
ACm300B4	40.5	522	288	331	467







### Application

- Can be used to transfer clean water or other liquids similar to water in physical and chemical properties
- Suitable for industrial use and urban water supply, pressure boosting for high buildings and fire fighting, garden irrigation, long-distance water transfer, heating ventilation and air controlling, circulation and pressure boosting for cold and hot water, and supporting equipment etc.

### Pump

- Cast iron pump body and support under special anti-rust treatment
- AISI 304 shaft
- Max. liquid temperature: +60°C
- Max. suction: +8 m

### Motor

- C&U bearing
- Motor with copper winding
- Built-in thermal protector for single phase motor (≤1.5 kW)
- Insulation class: F
- Protection class: IPX4
- Max. ambient temperature: +40°C
- IE 2 motor (Three phase, power ≥ 0.75kW)

### Identification Codes

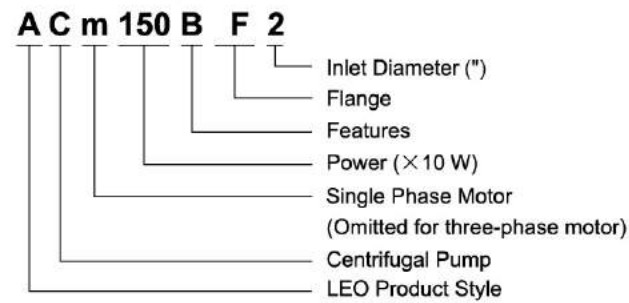

### Technical Data

MODEL		POWER		Q (m³/h)													
Single Phase	Three Phase	kW	HP	0	12	18	24	30	36	42	48	54	60	66	72	84	96
ACm110BF2	AC110BF2	1.1	1.5	0	200	300	400	500	600	700	800	900	1000	1100	1200	1400	1600
ACm110BF3	AC110BF3	1.1	1.5	19.5	18.5	16.5	13	8.5	-	-	-	-	-	-	-	-	-
ACm150BF2	AC150BF2	1.5	2	12.5	12.5	21.1	11.5	10.5	9.5	8.4	7.1	5.5	-	-	-	-	-
ACm150BF3	AC150BF3	1.5	2	22	20.5	18.3	14.5	9.5	-	-	-	-	-	-	-	-	-
ACm220BF3	AC220BF3	2.2	3	14.5	14.3	14	13.5	12.8	12	11.2	9.9	8.4	6	-	-	-	-
ACm400BF4	AC400BF4	4	5.5	17.5	17.3	17.1	16.5	16	15.2	14.2	14.2	11.7	10	7.2	-	-	-
				16.5	-	-	16	15.8	15.5	15.3	15.3	15	14.7	14.4	14	13.2	12.1

### Dimension

Model	DN1	DN2	L (mm)	W (mm)	H (mm)	L <sub>1</sub> (mm)	W <sub>1</sub> (mm)	H <sub>1</sub> (mm)	D (mm)
ACm110BF2	2"	2"	392	206	270	64.5	166	112	10
ACm110BF3	3"	3"	403	230	300	86	180	120	12
ACm150BF2	2"	2"	392	206	270	64.5	166	112	10
ACm150BF3	3"	3"	403	230	300	86	180	120	12
ACm220BF3	3"	3"	471	230	300	86	180	120	12
ACm400BF4	4"	4"	593	281.5	398	120.5	206	160	16

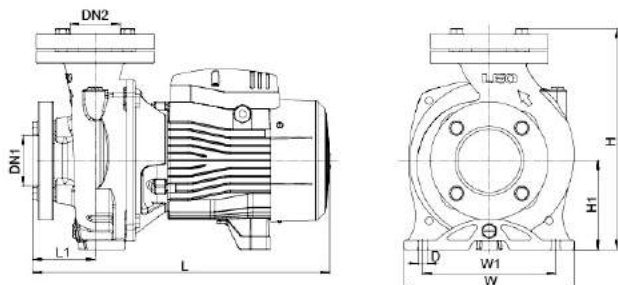

### Hydraulic Performance Curves

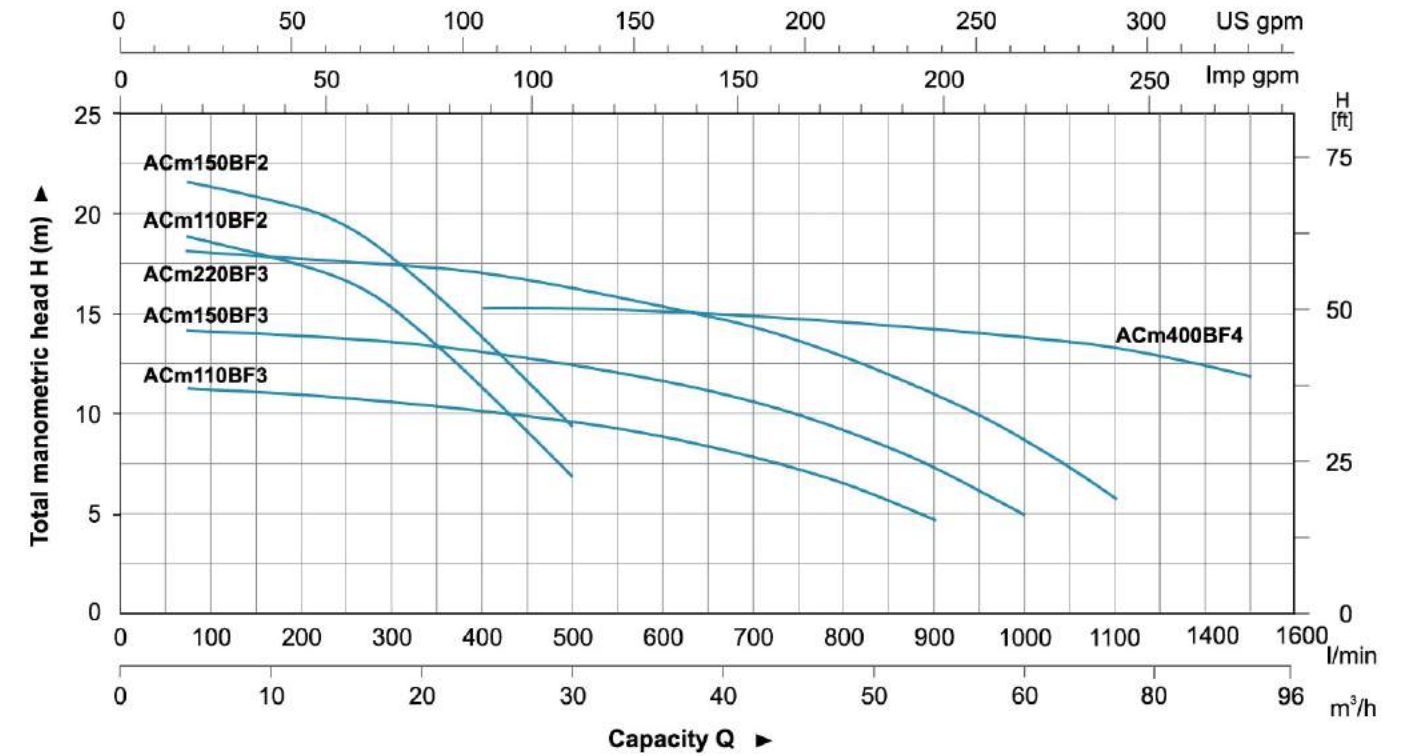

### Materials Table

No.	Part	Material
1	Flange	HT200
2	Pump body	HT200
3	Impeller	AISI 304/Brass HT200
4	Mechanical seal	Carbon/Ceramic
5	Oil seal	
6	Support	HT200
7	Bearing	
8	Rotor	
9	Fan cover	PP
10	Fan	PP
11	Rear cover	HT200
12	Stator	
13	Capacitor	
14	Terminal box	PA6-GF25

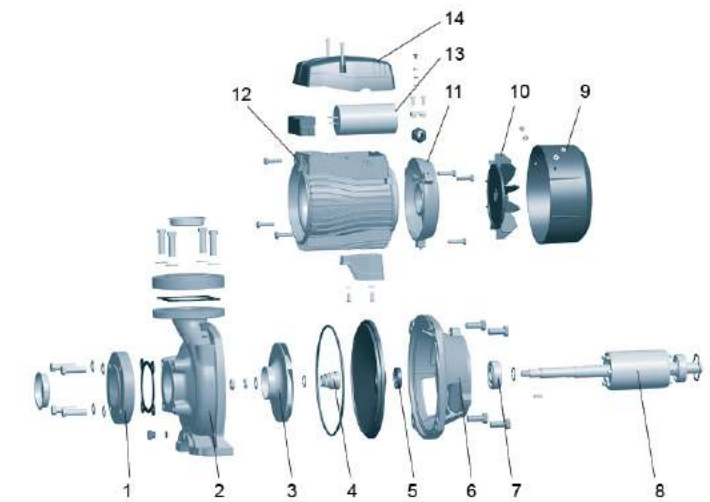

### Package Information

Model	GW (Kgs)	L (mm)	W (mm)	H (mm)	Quantity (PCS/20 TEU)
ACm110BF2	22.2	414	230	300	900
ACm150BF2	24	414	230	300	833
ACm110BF3	31.5	433	255	332	634
ACm150BF3	32.5	433	255	332	615
ACm220BF3	40	522	288	332	500
ACm400BF4	72.8	658	330	457	204







## Application

- Can be used to transfer clean water or other liquids similar to water in physical and chemical properties
- Suitable for industrial use and urban water supply, pressure boosting for high buildings and fire fighting, garden irrigation, long-distance water transfer, heating ventilation and air controlling, circulation and pressure boosting for cold and hot water, and supporting equipment, etc.

## Pump

- Cast iron pump body and support under special anti-rust treatment
- AISI 304 shaft
- Max. liquid temperature: +60 °C
- Max. suction: 8 m

## Motor

- C&U bearing
- Motor with copper winding
- Built-in thermal protector for single phase motor
- Insulation class: F
- Protection class: IPX4
- Max. ambient temperature: +40 °C
- IE2 motor for XG/1A

## Identification Codes

**XG m / 1 A**

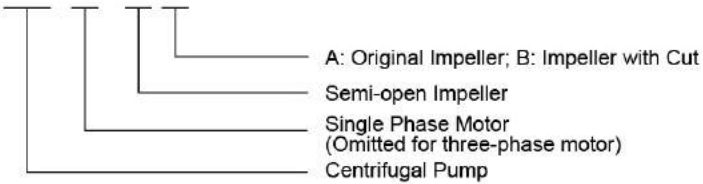

## Technical Data

Model		POWER		Q (m³/h)													
Single Phase	Three Phase	kW	HP	0	2.4	4.2	6	7.8	9.6	11.4	13.2	14.7					
				Q (l/min)	0	40	70	100	130	160	190	220	245				
XGm/1A	XG/1A	0.75	1	H (m)	17.5	16	14.5	13	11	9	6.5	3.5	1				
XGm/1B	XG/1B	0.6	0.8		14	12.5	11	9.5	7.5	5.5	3	-	-				

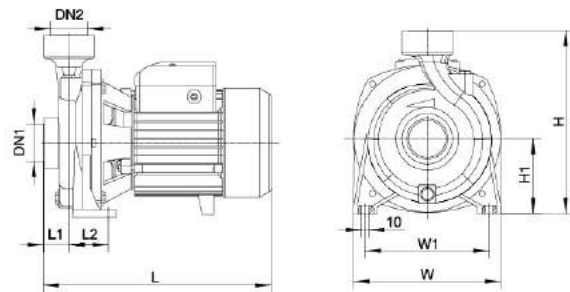

## Dimension

Model	DN1	DN2	L (mm)	W (mm)	H (mm)	L1 (mm)	L2 (mm)	W1 (mm)	H1 (mm)
XGm/1A	1 1/2"	1 1/2"	295	191	235	44	48	160	96.5
XGm/1B									

## Hydraulic Performance Curves

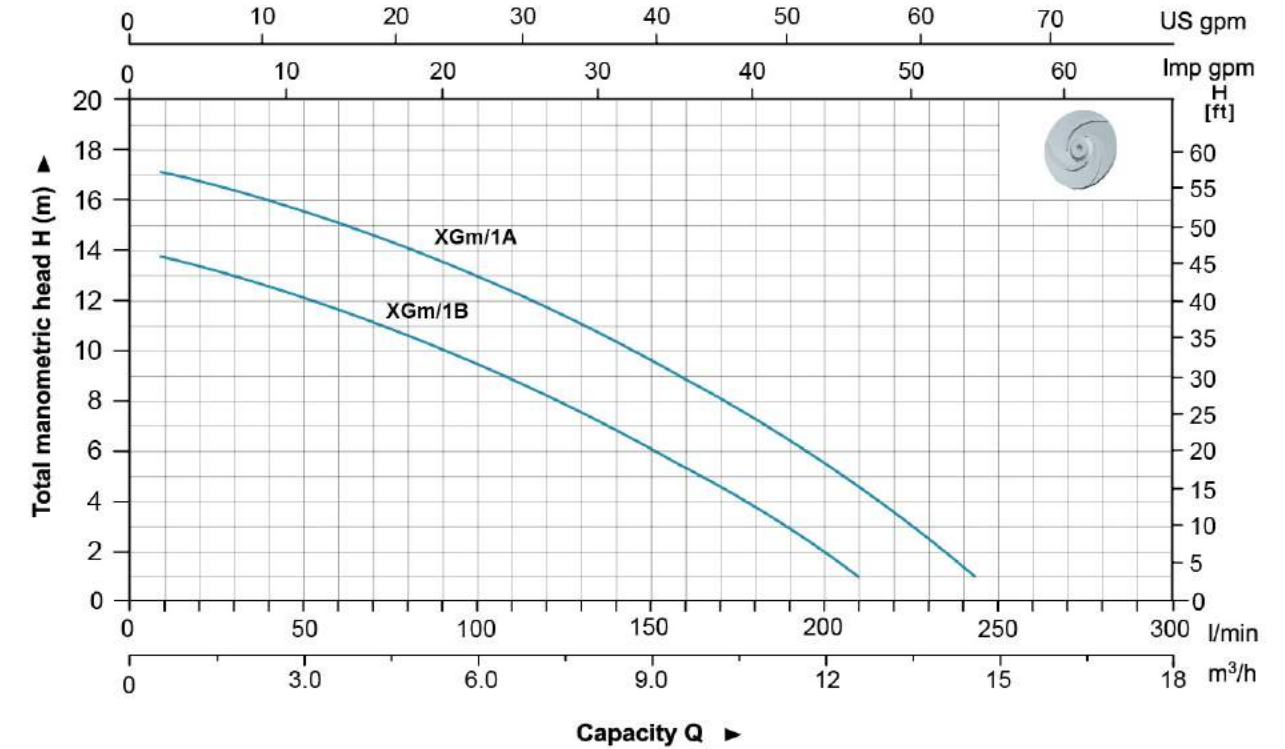

## Materials Table

No.	Part	Material
1	Pump body	HT200
2	Impeller	Brass
3	Mechanical seal	Carbon/Ceramic
4	Bracket cover	AISI 304
5	Support	ZL102
6	Bearing	
7	Rotor	
8	Stator	
9	Capacitor	
10	Rear cover	ZL102
11	Fan	PP
12	Fan cover	08F

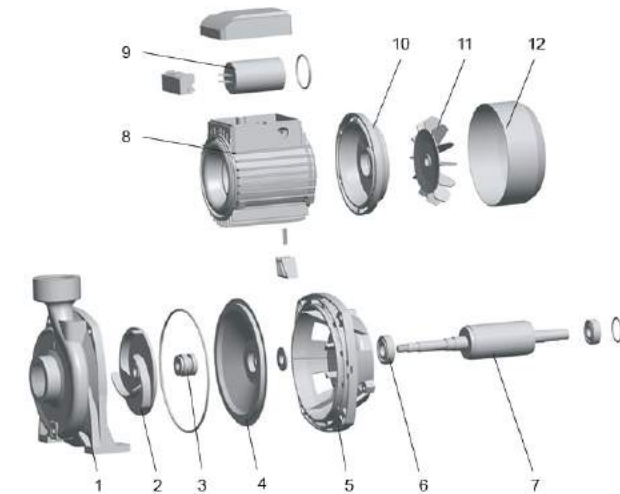

## Package Information

Model	GW (Kgs)	L (mm)	W (mm)	H (mm)	Quantity (PCS/20 TEU)
XGm/1A	13	325	242	265	1512
XGm/1B	11.5	325	242	265	1512











### Application

- Can be used to transfer clean water or other liquids similar to water in physical and chemical properties
- Suitable for industrial use and urban water supply, domestic water supply, high rise buildings, long distance water transfer and related auxiliary equipment etc.

### Pump

- Cast iron pump body and support under special anti-rust treatment
- AISI 304 shaft
- Max. liquid temperature: +60°C
- Max. suction: +8 m
- Self-priming

### Motor

- C&U bearing
- Motor with copper winding
- Built-in thermal protector for single phase motor
- Insulation class: F
- Protection class: IPX4
- Max. ambient Temperature: +40°C
- IE 2 motor for 4AC75

### Identification Codes

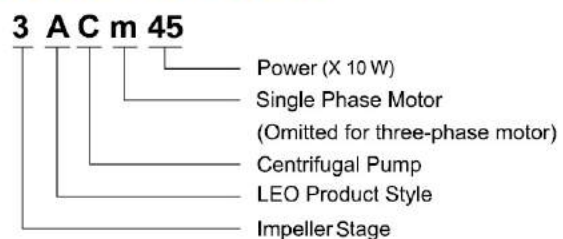

### Technical Data

MODEL		POWER		Q (m³/h)																												
Single Phase	Three Phase	kW	HP	0	0.3	0.6	0.9	1.2	1.5	1.8	2.4	3.0	3.6	4.2	4.8	5.4	Q (l/min)															
			H (m)																													
3ACm45	—	0.45	0.6	35	33.5	32.5	31.5	30	28.5	26.5	23	18.5	14	9	-	-	0	5	10	15	20	25	30	40	50	60	70	80	90			
4ACm60	—	0.6	0.85	46.5	45	44	42.5	40.5	38.5	36	30	24	17	10	-	-	0	5	10	15	20	25	30	40	50	60	70	80	90			
3ACm60	—	0.6	0.85	36	35.5	35	34.5	34	33.5	32.5	30.5	28.5	26	23	19	13.5	0	5	10	15	20	25	30	40	50	60	70	80	90			
4ACm75	4AC75	0.75	1	46.5	45	44	43	42	41	40	38	35.5	32.5	28	23	17	0	5	10	15	20	25	30	40	50	60	70	80	90			

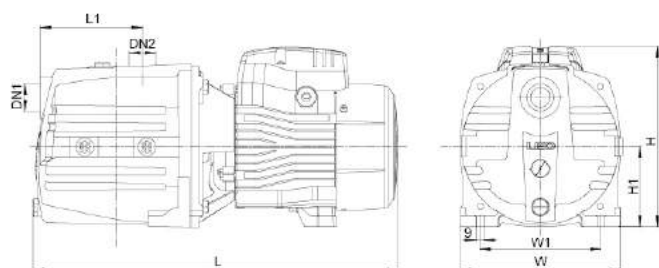

### Dimension

Model	DN1	DN2	L (mm)	W (mm)	H (mm)	L <sub>1</sub> (mm)	W <sub>1</sub> (mm)	H <sub>1</sub> (mm)
3ACm45	1"	1"	368	180	183	90	136	90
4ACm60			405	180	183	115	136	90
3ACm60			485	180	202	90	136	90
4ACm75			510	180	202	115	136	90

### Hydraulic Performance Curves

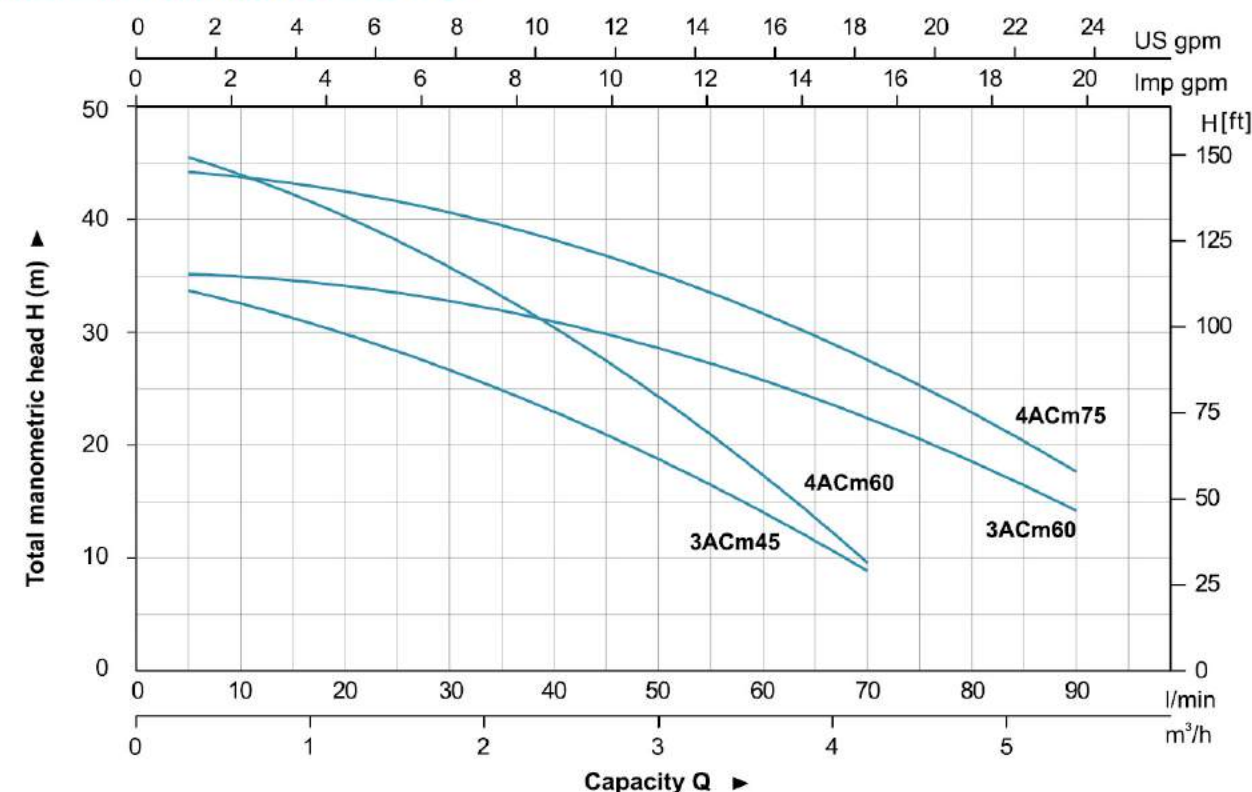

### Materials Table

No.	Part	Material
1	Pump body	HT200
2	Pump cover	PPO
3	Return valve	PPO
4	Diffuser 1	PPO
5	Impeller	PPO
6	Diffuser 2	PPO
7	Diffuser holder	PPO
8	Support frame	PPO
9	Mechanical seal	Carbon/Ceramic
10	Bracket cover	HT200
11	Oil seal	
12	Support	ZL102
13	Bearing	
14	Rotor	
15	Stator	
16	Terminal box	PA6-GF25
17	Capacitor	
18	Rear cover	ZL102
19	Fan	PP
20	Fan cover	PP

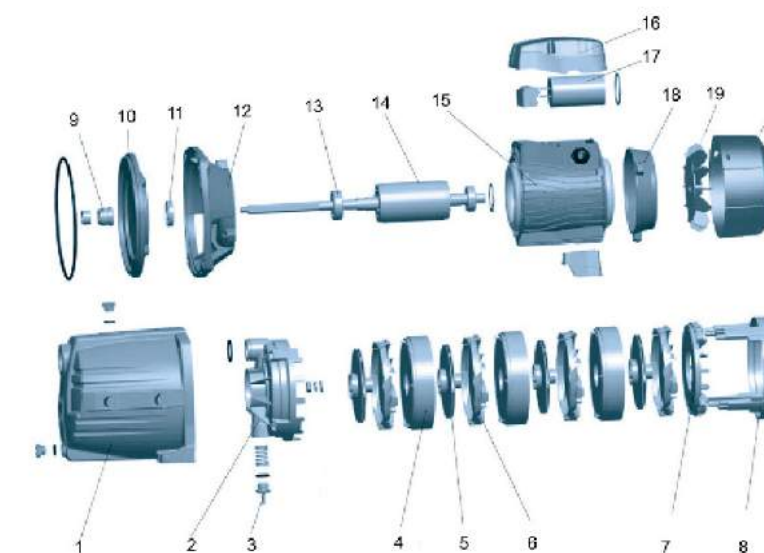

### Package Information

Model	GW (Kgs)	L (mm)	W (mm)	H (mm)	Quantity (PCS/20' TEU)
3ACm45	13.2	410	200	210	1515
4ACm60	16	460	200	230	1233
3ACm60	15.3	435	200	230	1305
4ACm75	17	460	200	230	1176







### Application

- Can be used to transfer clean water or other liquids similar to water in physical and chemical properties
- Suitable for pumping water from lake, river and well
- Industrial use and agricultural irrigation

### Pump

- Cast iron pump body and support under special anti-rust treatment
- AISI 304 shaft
- Max. liquid temperature: +60°C
- Max. suction: 8 m

### Motor

- C&U bearing
- Motor with copper winding
- Built-in thermal protector for single phase motor
- Insulation class: F
- Protection class: IPX4
- Max. ambient temperature: +40°C
- IE 2 motor (Three phase, power ≥ 0.75kW)

### Identification Codes

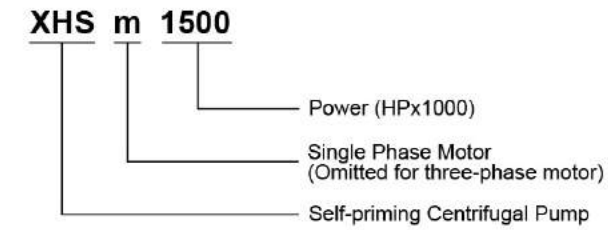

### Technical Data

Model		POWER		Q (m³/h)																				
Single Phase	Three Phase	kW	HP	0	2.1	4.5	6.6	8.1	10.2	12	14.1	16.2	19.8											
				Q (l/min)	0	35	75	110	135	170	200	235	270	330										
XHSm1500	XHS1500	1.1	1.5	H (m)	15	14	12.5	11	10	8.5	7	5	2.5	-										
XHSm2000	XHS2000	1.5	2		20.5	19	17.5	16	15	13.5	12	10	7.5	2.5										

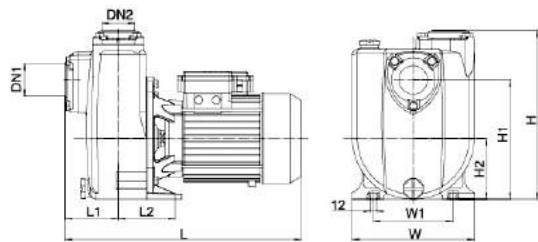

### Dimension

Model	DN1	DN2	L (mm)	W (mm)	H (mm)	L1 (mm)	L2 (mm)	W1 (mm)	H1 (mm)	H2 (mm)
XHSm1500	2"	2"	430	222	308	96.5	104	145	218	111
XHSm2000										

### Hydraulic Performance Curves

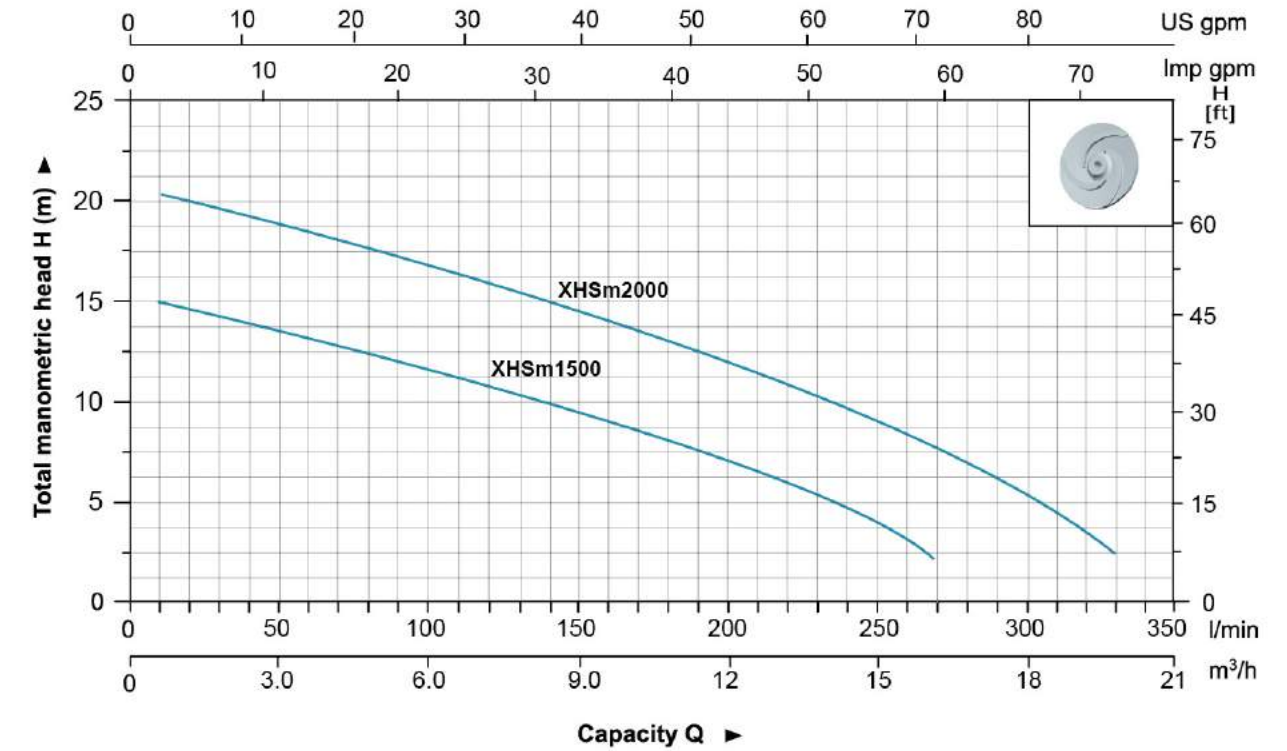

### Materials Table

No.	Part	Material
1	Fan cover	08F
2	Fan	PP
3	Rear cover	ZL 102
4	Rotor	
5	Bearing	
6	Stator	
7	Support	HT200
8	Mechanical seal	Carbon/Ceramic
9	Impeller	HT200
10	Pump body	HT200
11	Inlet adaptor	HT200
12	Non-return valve	NBR
13	Capacitor	

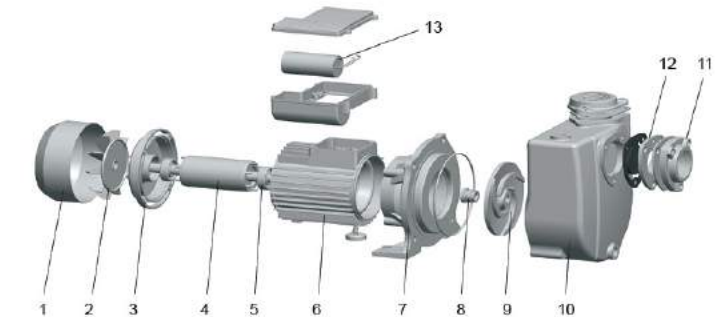

### Package Information

Model	CW (Kgs)	L (mm)	W (mm)	H (mm)	Quantity (PCS/20' TEU)
XHSm1500	34.5	475	280	380	580
XHSm2000	36.5	475	280	380	580

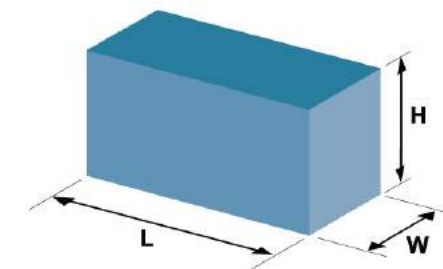





### Application

- Can be used to transfer clean water or other liquids similar to water in physical and chemical properties
- Suitable for industrial use and urban water supply, domestic water supply, high rise buildings, long distance water transfer and related auxiliary equipment etc.

### Pump

- Cast iron pump body and support under special anti-rust treatment
- AISI 304 shaft
- Max. liquid temperature: +60°C
- Max. suction: +8 m

### Motor

- C&U bearing
- Motor with copper winding
- Built-in thermal protector for single phase motor
- Insulation class: F
- Protection class: IPX4
- Max. ambient Temperature: +40°C
- IE 2 motor (Three phase, power ≥ 0.75kW)

### Identification Codes

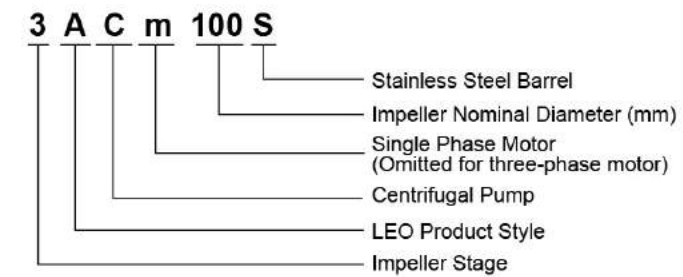

### Technical Data

Model		POWER		Q (m³/h)											
Single Phase	Three Phase	kW	HP	0	0.6	1.2	1.8	2.4	3.0	3.6	4.2	4.8	5.4	6.0	
				Q (l/min)											
				H (m)											
3ACm100S	3AC100S	0.6	0.8	35	33.5	31.5	29	26.5	24	20.5	16	12	7	-	
4ACm100S	4AC100S	0.75	1	45	41	38.5	36	33	30	25.5	21	15	9	-	
5ACm100S	5AC100S	0.9	1.2	55	54	52	49	45	40	35	29	22.5	15	8	

### Hydraulic Performance Curves

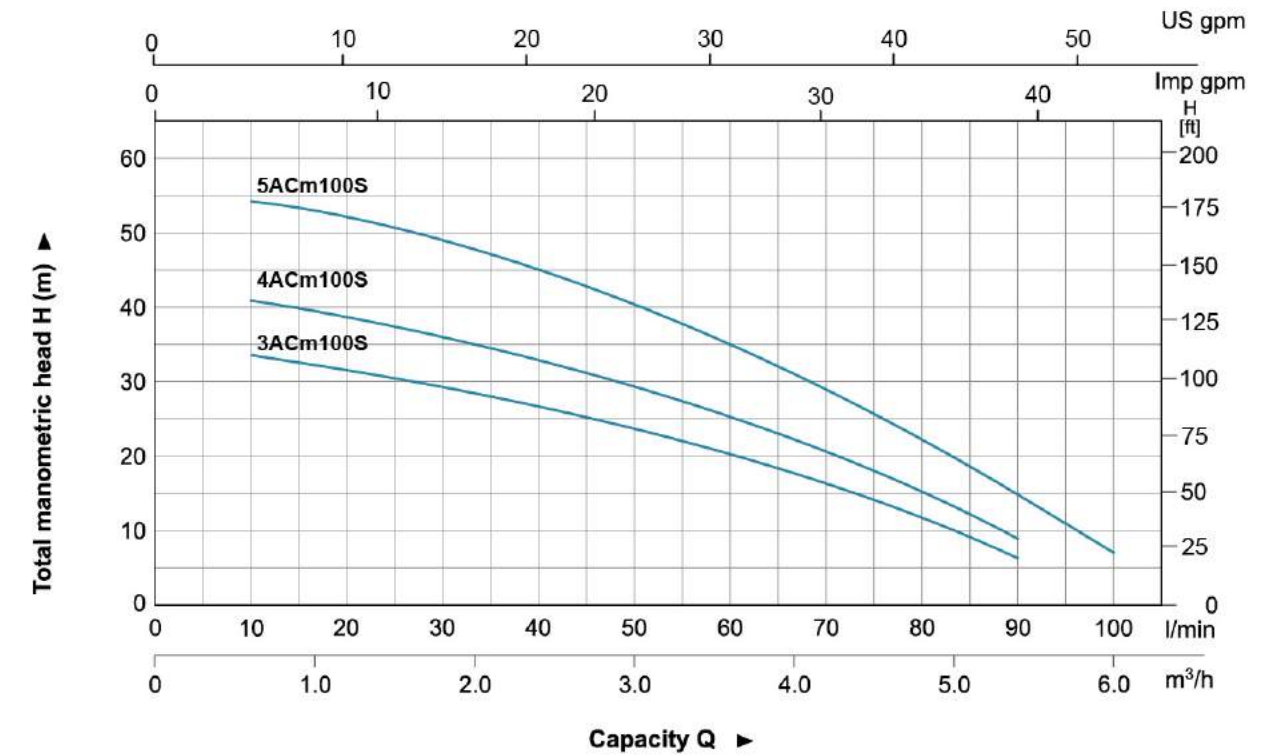

### Materials Table

No.	Part	Material	No.	Part	Material
1	Pump body	HT200	14	Cable holder	
2	Seal washer	NBR	15	Capacitor box	PA6-GF25
3	Pump barrel	AISI304	16	Capacitor	
4	Impeller	PPO	17	Terminal board	
5	Drain cover	PPO	18	Stator	
6	Diffuser	PPO	19	Rotor	
7	Mechanical seal	Carbon/Ceramic	20	Bearing	
8	Support	HT200			
9	Water proof gland	NBR			
10	Fan cover	PP			
11	Fan	PP			
12	Rear cover	ZL102			
13	Spring washer	65Mn			

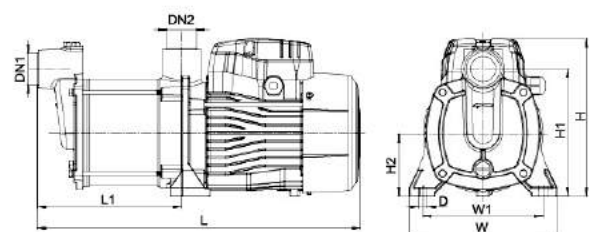
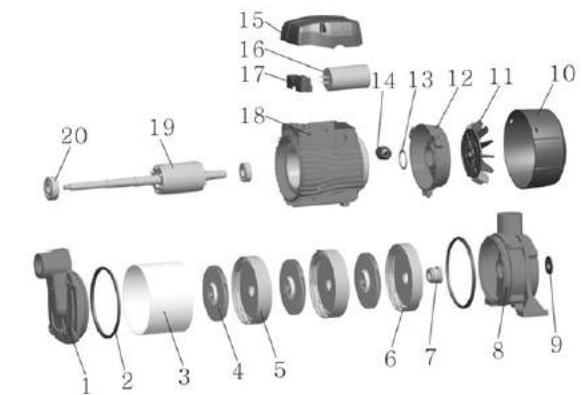

### Dimension

Model	DN1	DN2	L (mm)	L1 (mm)	W (mm)	W1 (mm)	H (mm)	H1 (mm)	H2 (mm)	D (mm)
3ACm100S	1"	1"	384	172	176	140	187	151	75	10
4ACm100S			408	196						
5ACm100S			432	220						

### Package Information

Model	GW (Kgs)	L (mm)	W (mm)	H (mm)	Quantity (PCS/20'TEU)
3ACm100S	12.5	405	210	230	1359
4ACm100S	13.5	430	210	230	1215
5ACm100S	14.5	455	210	230	1188





# ACSm

## Self-Priming Stainless Steel Multistage Centrifugal Pump



### Application

- Can be used to transfer clean water or other liquids similar to water in physical and chemical properties
- Suitable for industrial use and urban water supply, domestic water supply, high rise buildings, long distance water transfer and related auxiliary equipment etc.

### Pump

- Pump with self-priming design
- Cast iron pump body and support under special anti-rust treatment
- AISI 304 shaft
- Max. liquid temperature: +60°C
- Max. suction: +8 m

### Motor

- C&U bearing
- Motor with copper winding
- Built-in thermal protector for single phase motor
- Insulation class: F
- Protection class: IPX4
- Max. ambient Temperature: +40°C
- IE 2 motor (Three phase, power ≥ 0.75kW)

### Identification Codes

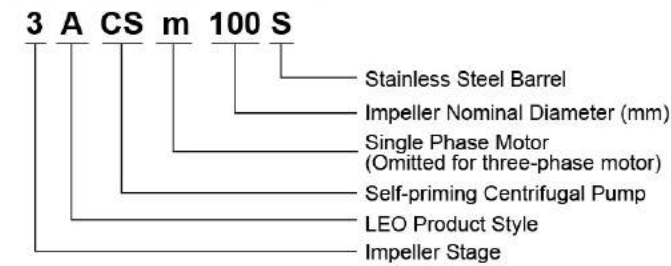

### Technical Data

Model		POWER		Q (m³/h)											
Single Phase	Three Phase	kW	HP	0	0.6	1.2	1.8	2.4	3.0	3.6	4.2	4.8	5.4	6.0	
				H (m)											
				0	10	20	30	40	50	60	70	80	90	100	
3ACSm100S	3ACS100S	0.6	0.8	35	33.5	31.5	29	26.5	24	20.5	16	12	7	-	
4ACSm100S	4ACS100S	0.75	1	45	41	38.5	36	33	30	25.5	21	15	9	-	
5ACSm100S	5ACS100S	0.9	1.2	55	54	52	49	45	40	35	29	22.5	15	8	

### Hydraulic Performance Curves

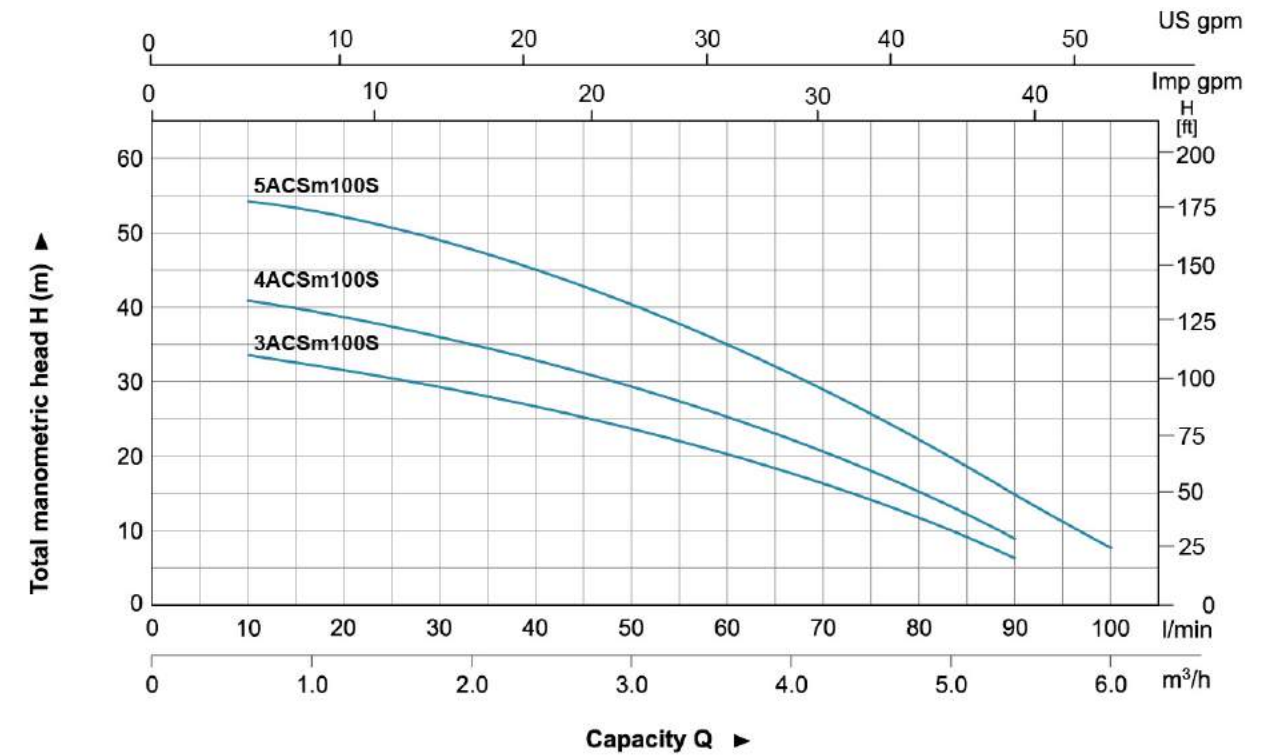

### Materials Table

No.	Part	Material	No.	Part	Material
1	Plug	HT200	14	Water proof gland	NBR
2	Return valve	NBR	15	Fan cover	PC/ABS
3	Spring	AISI304	16	Fan	PPO
4	Nozzle	PPO	17	Rear cover	ZL102
5	Pump body	PPO	18	Spring washer	65Mn
6	Seal washer	PPO	19	Cable holder	
7	Pump barrel	AISI304	20	Capacitor box	PA6-GF25
8	Pump cover	PPO	21	Capacitor	
9	Impeller	PPO	22	Terminal board	
10	Drain cover	PPO	23	Stator	
11	Diffuser	PPO	24	Bearing	
12	Mechanical seal	Carbon/Ceramic	25	Rotor	
13	Support	HT200			

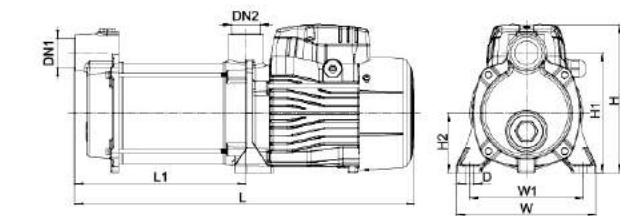
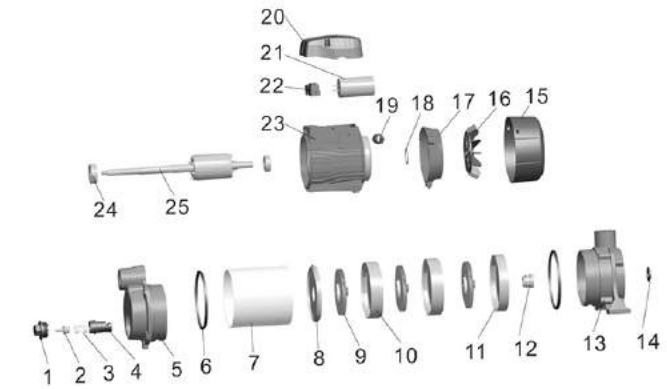

### Dimension

Model	DN1	DN2	L (mm)	L1 (mm)	W (mm)	W1 (mm)	H (mm)	H1 (mm)	H2 (mm)	D (mm)
3ACSm100S	1"	1"	429	216	176	140	187	151	75	10
4ACSm100S			453	240						
5ACSm100S			477	264						

### Package Information

Model	GW (Kgs)	L (mm)	W (mm)	H (mm)	Quantity (PCS/20'TEU)
3ACSm100S	13.1	455	210	230	1188
4ACSm100S	14.1	480	210	230	1116
5ACSm100S	15.1	505	210	230	1089





**Application**

- Can be used to transfer clean water or other liquids similar to water in physical and chemical properties
- Suitable for industrial use and urban water supply, domestic water supply, high rise buildings, long distance water transfer and related auxiliary equipment etc.

**Pump**

- Stainless steel pump body
- AISI 304 shaft
- Max. liquid temperature: +60°C
- Max. suction: +8 m

**Motor**

- C&U bearing
- Motor with copper winding
- Built-in thermal protector for single phase motor
- Insulation class: F
- Protection class: IPX4
- Max. ambient Temperature: +40°C

**Identification Codes**

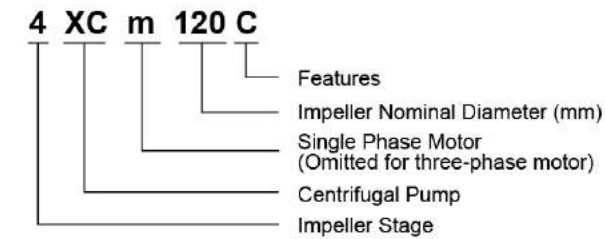

**Technical Data**

Model		POWER		Q (m³/h)																					
Single Phase	Three Phase	kW	HP	0	0.6	1.2	1.8	2.4	3	3.6	4.2	4.8	4.9	5											
				Q (l/min)	0	10	20	30	40	50	60	70	80	82	84										
3XCm120C	—	0.6	0.8	<b>H (m)</b>	34	33	31.5	29	26	22	17.5	11.5	3.5	-	-										
4XCm120C	4XC120C	0.75	1		48	45.5	42.5	39.5	36	31.5	26	18.8	9	3	-										
5XCm120C	5XC120C	0.9	1.2		56.5	54.5	52	48.2	44	38.5	32	24	15	12.5	3										

**Dimension**

Model	DN1	DN2	L (mm)	W (mm)	H (mm)	L1 (mm)	W1 (mm)	H1 (mm)
3XCm120C	1"	1"	362	174	208	77	140	103
4XCm120C	1"	1"	386	174	208	104	140	103
5XCm120C	1"	1"	410	174	208	125	140	103

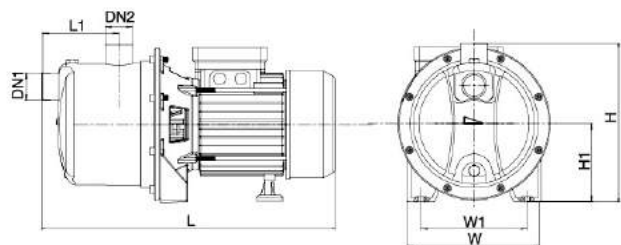

**Hydraulic Performance Curves**

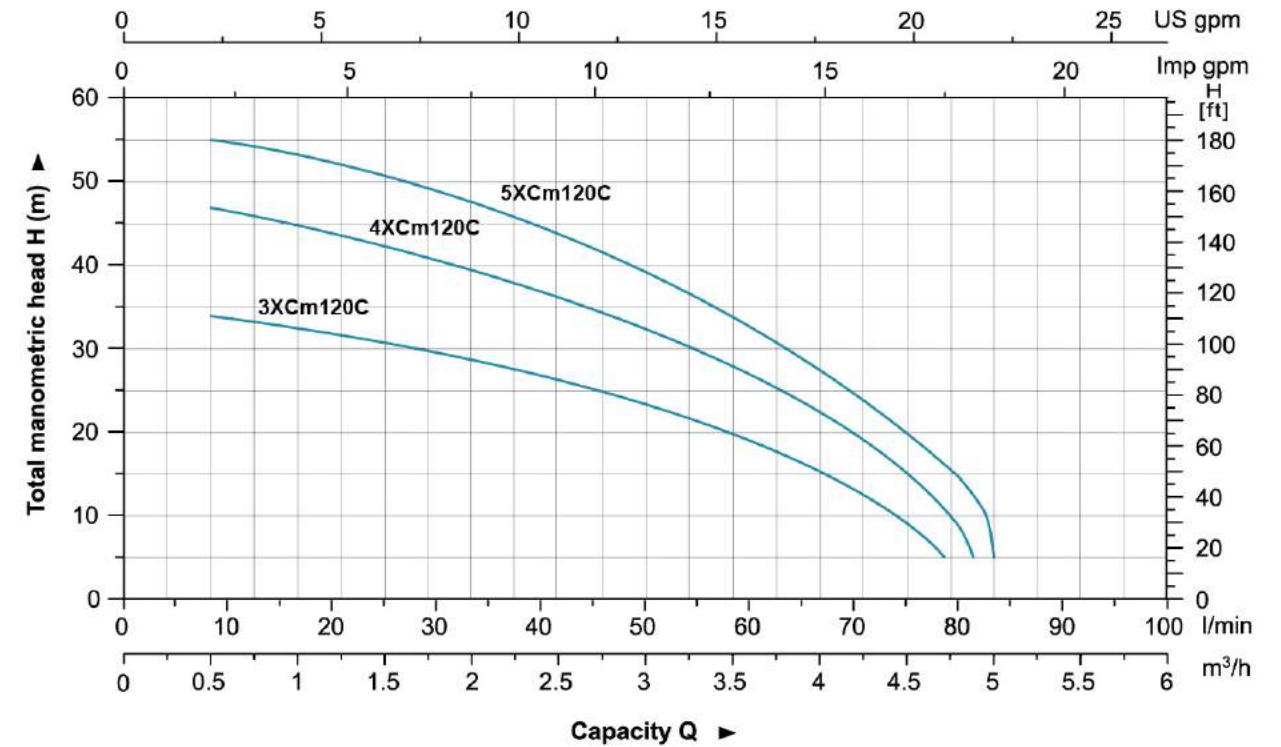

**Materials Table**

No.	Part	Material
1	Pump body	AISI 304
2	Pump cover	PPO
3	Impeller	PPO
4	Diffuser	PPO
5	Water guiding board	PPO
6	O-ring	NBR
7	Mechanical seal	Carbon/Ceramic
8	Bracket cover	AISI 304
9	Rubber washer	
10	Support	ZL102
11	Ball bearing	
12	Rotor	
13	Stator	
14	Rear cover	ZL102
15	Fan	PP
16	Fan cover	08F
17	Terminal cover	ABS
18	Capacitor	
19	Terminal	
20	Terminal box	ABS

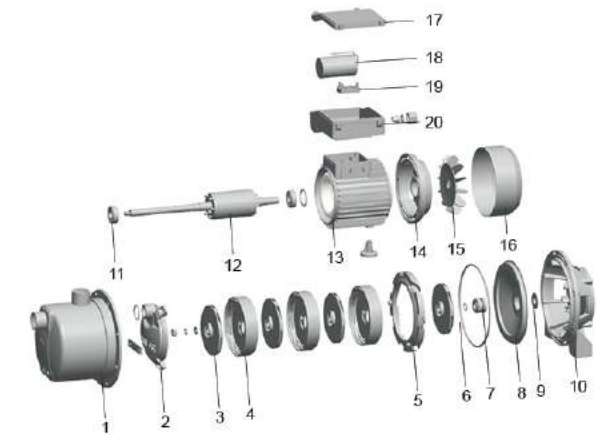

**Package Information**

Model	GW (Kgs)	L (mm)	W (mm)	H (mm)	Quantity (PCS/20' TEU)
3XCm120C	9.5	405	235	265	1072
4XCm120C	10.5	430	235	265	1008
5XCm120C	11.5	455	235	265	960







**Application**

- It is applicable to household water supply, equipment support, pipeline pressurization, garden watering, vegetable greenhouse watering, fish farming and poultry raising, industrial and mining, water supply and drainage of enterprises and high-rise buildings, central air conditioner and centralized heating circulation system, etc.

**Pump**

- AISI 304 pump body
- AISI 304 shaft
- Max. liquid temperature: +85°C
- Altitude: up to 1000 m

**Motor**

- C&U bearing
- Motor with copper winding
- Built-in thermal protector for single phase motor
- Insulation class: F
- Protection class: IPX4
- Max. temperature: +40°C

**Identification Codes**

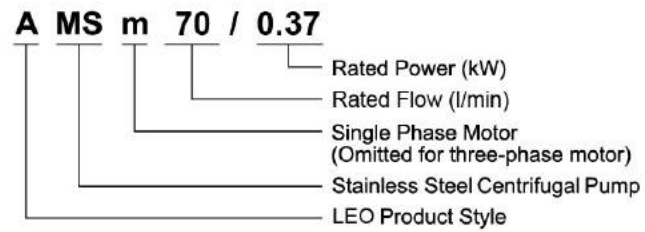

**Hydraulic Performance Curves**

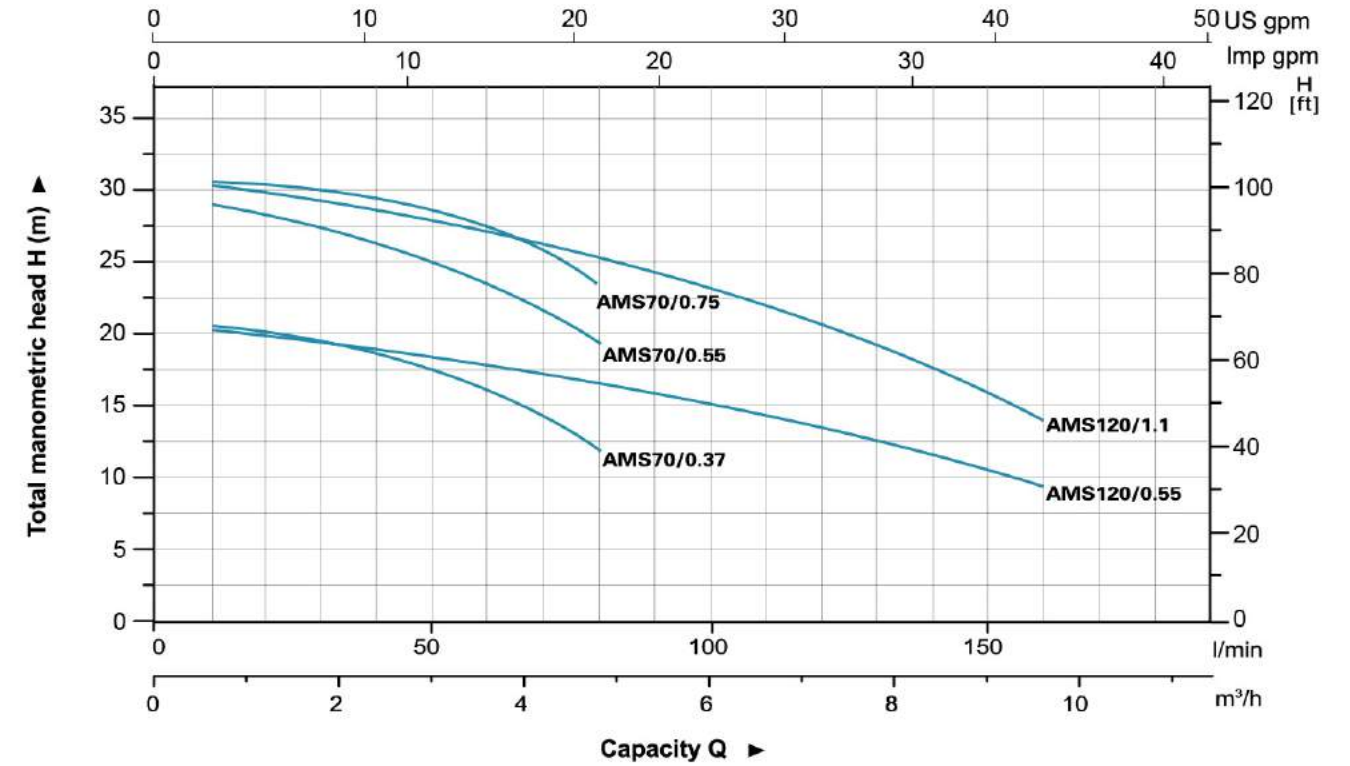

**Technical Data**

MODEL		POWER		Q (m³/h)		0	1.8	2.4	3.6	4.8	6	7.2	8.4	9.6	10.8
Single Phase	Three Phase	kW	HP	Q (l/min)	H (m)	0	30	40	60	80	100	120	140	160	180
AMSm70/0.37	AMS70/0.37	0.37	0.5			20.9	19.0	18.1	15.7	12.1	-	-	-	-	-
AMSm70/0.55	AMS70/0.55	0.55	0.75			29.5	27.3	26.3	23.4	19.1	-	-	-	-	-
AMSm70/0.75	AMS70/0.75	0.75	1.0			30.4	28.5	27.8	26.0	23.0	-	-	-	-	-
AMSm120/0.55	AMS120/0.55	0.55	0.75			20.2	-	-	17.9	16.6	15.1	13.3	11.2	8.7	-
AMSm120/1.1	AMS120/1.1	1.1	1.5			30.2	-	-	26.7	25.1	23.3	21.2	19.0	16.4	-

**Materials Table**

No.	Part	Material
1	Bottom support	Steel
2	Pump body	AISI 304
3	Diffuser	AISI 304
4	Impeller	AISI 304
5	O-ring	NBR
6	Airproof plate	AISI 304
7	Support	ZL102
8	Mechanical seal	Silicon/Carbon
9	Ball bearing	
10	Rotor	
11	Stator	
12	Fan	PP
13	Rear housing	ZL102
14	Fan cover	PP
15	Terminal box	ABS

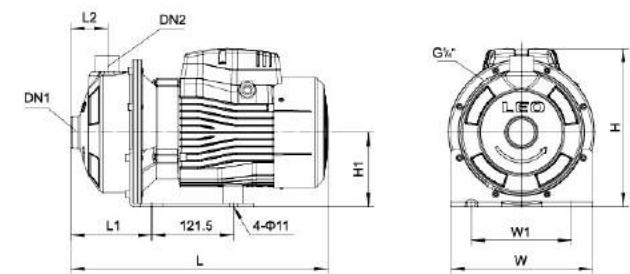
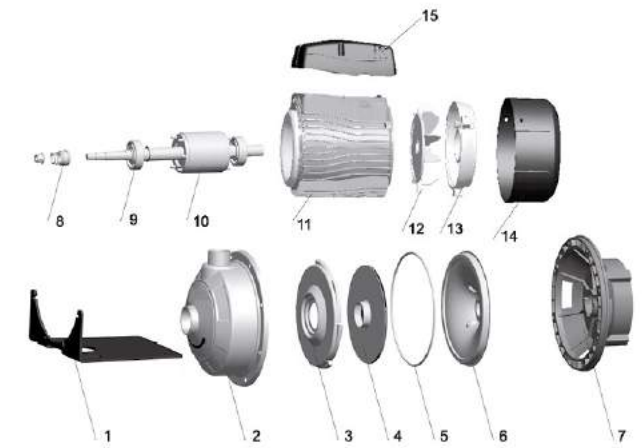

**Dimension**

Model	Ports		L (mm)	W (mm)	H (mm)	L <sub>1</sub> (mm)	L <sub>2</sub> (mm)	W <sub>1</sub> (mm)	H <sub>1</sub> (mm)
	DN1	DN2							
AMS70/0.37	1 1/4"	1"	332	210	224	119	55	149	110
AMS70/0.55	1 1/4"	1"	332	210	224	119	55	149	110
AMS70/0.75	1 1/4"	1"	381	210	234	119	55	149	110
AMS120/0.55	1 1/4"	1"	332	210	224	119	55	149	110
AMS120/1.1	1 1/4"	1"	381	210	234	119	55	149	110

**Package Information**

Model	GW (Kgs)	L (mm)	W (mm)	H (mm)	Quantity (PCS/20 TEU)
AMS70/0.37	10	380	240	270	1200
AMS70/0.55	11	380	240	270	1200
AMS70/0.75	14	410	240	270	1104
AMS120/0.55	11	380	240	270	1200
AMS120/1.1	15	410	240	270	1104







**Application**

- It is applicable to household water supply, equipment support, pipeline pressurization, garden watering, vegetable greenhouse watering, fish farming and poultry raising, industrial and mining, water supply and drainage of enterprises and high-rise buildings, central air conditioner and centralized heating circulation system, etc.

**Pump**

- AISI 304 pump body
- AISI 304 shaft
- Max. liquid temperature: +85°C
- Altitude: up to 1000 m

**Motor**

- C&U bearing
- Motor with copper winding
- Built-in thermal protector for single phase motor
- Insulation class: F
- Protection class: IPX4
- Max. temperature: +40°C

**Identification Codes**

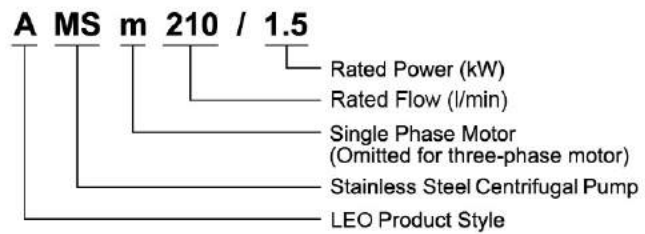

**Technical Data**

MODEL		POWER		Q (m³/h)																
Single Phase	Three Phase	kW	HP	0	1.8	3.6	6	7.2	8.4	9.6	10.8	12	15	18	21	24	26	29	31	
				H (m)																
				0	30	60	100	120	140	160	180	200	250	300	350	400	430	480	520	
AMSm210/0.75	AMS210/0.75	0.75	1.0	16.8	-	-	-	15.6	15.2	14.8	14.2	13.6	11.9	9.8	-	-	-	-	-	
AMSm210/1.1	AMS210/1.1	1.1	1.5	19.7	-	-	-	18.7	18.3	18.0	17.5	17.1	15.6	13.6	-	-	-	-	-	
AMSm210/1.5	AMS210/1.5	1.5	2.0	24.2	-	-	-	23.5	23.2	22.8	22.4	21.8	20.2	18.0	-	-	-	-	-	
AMSm210/2.2	AMS210/2.2	2.2	3.0	27.5	-	-	-	26.7	26.5	26.1	25.7	25.2	23.8	21.9	-	-	-	-	-	
AMSm370/1.1	AMS370/1.1	1.1	1.5	15.4	-	-	-	-	-	-	14.7	14.4	13.5	12.3	10.8	8.9	7.6	-	-	
AMSm370/1.5	AMS370/1.5	1.5	2.0	19.3	-	-	-	-	-	-	18.1	17.3	16.3	15.0	13.3	12.3	10.2	-	-	
AMSm370/2.2	AMS370/2.2	2.2	3.0	23.1	-	-	-	-	-	-	21.7	20.9	20.0	18.8	17.2	16.2	14.2	12.3	-	

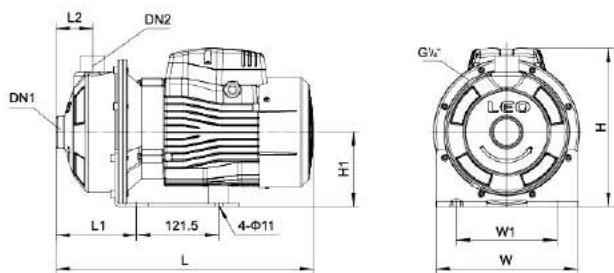

**Dimension**

Model	Ports		L (mm)	W (mm)	H (mm)	L <sub>1</sub> (mm)	L <sub>2</sub> (mm)	W <sub>1</sub> (mm)	H <sub>1</sub> (mm)
	DN1	DN2							
AMS210/0.75	1 1/2"	1 1/4"	392	210	234	129	55	149	110
AMS210/1.1	1 1/2"	1 1/4"	392	210	234	129	55	149	110
AMS210/1.5	1 1/2"	1 1/4"	440	210	250	129	55	149	110
AMS210/2.2	1 1/2"	1 1/4"	440	210	250	129	55	149	110
AMS370/1.1	2"	1 1/4"	392	210	234	129	55	149	110
AMS370/1.5	2"	1 1/4"	440	210	250	129	55	149	110
AMS370/2.2	2"	1 1/4"	440	210	250	129	55	149	110

**Hydraulic Performance Curves**

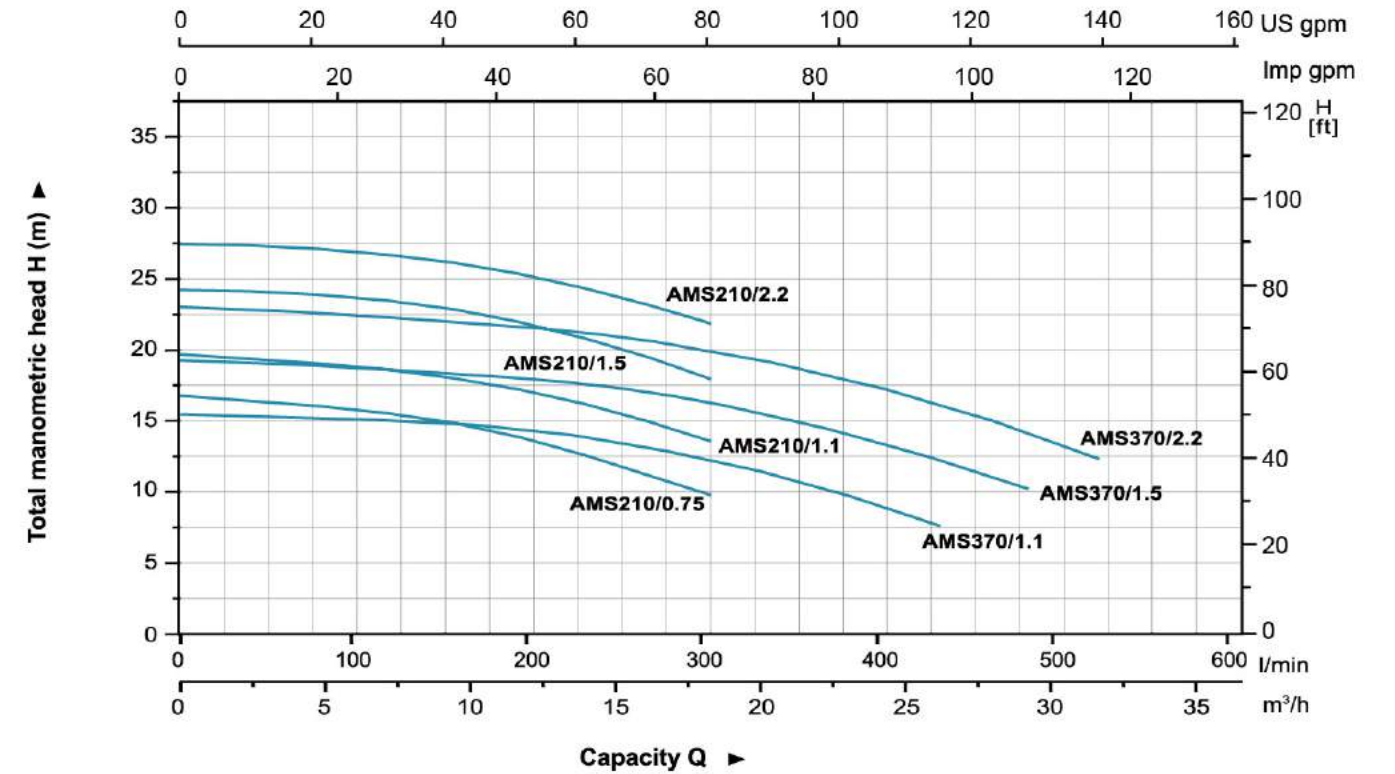

**Materials Table**

No.	Part	Material
1	Bottom support	Steel
2	Pump body	AISI 304
3	Diffuser	AISI 304
4	Impeller	AISI 304
5	O-ring	NBR
6	Airproof plate	AISI 304
7	Support	ZL102
8	Mechanical seal	Silicon/Carbon
9	Ball bearing	
10	Rotor	
11	Stator	
12	Fan	PP
13	Rear housing	ZL102
14	Fan cover	PP
15	Terminal box	ABS

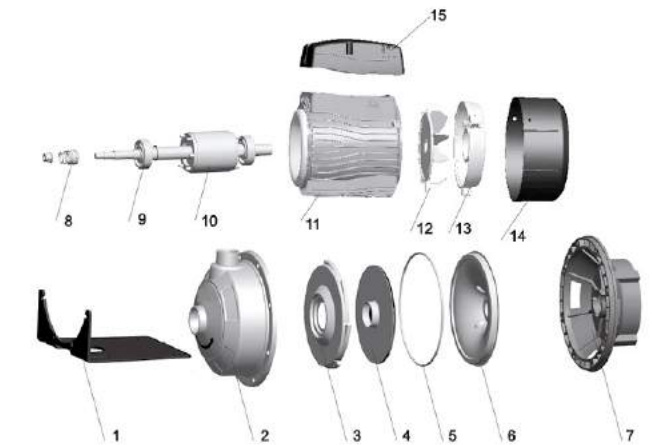

**Package Information**

Model	GW (Kgs)	L (mm)	W (mm)	H (mm)	Quantity (PCS/20 TEU)
AMS210/0.75	14	410	240	270	1104
AMS210/1.1	15	410	240	270	1104
AMS210/1.5	18	465	240	270	968
AMS210/2.2	20	465	240	270	968
AMS370/1.1	15	410	240	270	1104
AMS370/1.5	18	465	240	270	968
AMS370/2.2	20	465	240	270	968







## Application

- Small electrical irrigation and drainage equipments
- Particularly applied in urban well water pumping, field irrigation and drainage, garden irrigation and household water supply, as well as drainage of industrial accumulated water, water supply and drainage for construction, livestock breeding, etc.

## Pump

- Cast iron pump body under special anti-rust treatment
- Max. immersion depth: 5 m
- Max. liquid temperature: +40°C
- Liquid pH value: 6.5 – 8

## Motor

- Copper winding
- Built-in thermal protector
- Stainless steel welded shaft
- Insulation class: B
- Protection class: IP68

## Identification Codes

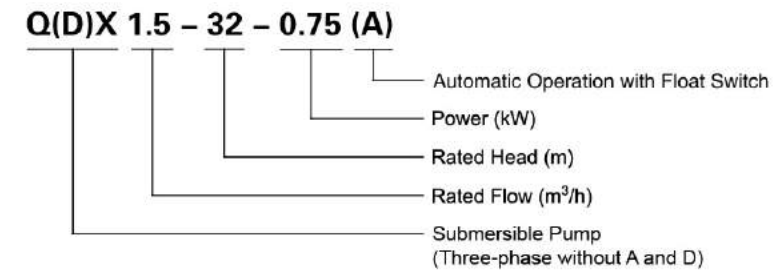

## Technical Data

Model	Q (m <sup>3</sup> /h)																
	0	1.5	3	4.5	6	7.5	9	10.5	12	13.5	15	16.5	18	19.5	21	22.5	24
*QDX1.5-12-0.25A	13	12	11	9	5.5	-	-	-	-	-	-	-	-	-	-	-	-
*QDX1.5-15-0.37A	16	15.6	14.2	12.3	9.8	-	-	-	-	-	-	-	-	-	-	-	-
*QDX1.5-25-0.55A	26.5	25	22.5	18	14	-	-	-	-	-	-	-	-	-	-	-	-
*QDX3-18-0.55A	19.2	19.1	18.5	17.5	15.5	13.2	10	7	3.7	-	-	-	-	-	-	-	-
*QDX10-10-0.55A	13.2	13.2	13.2	13	12.7	12	11	10	9.2	7.5	6	-	-	-	-	-	-
*QDX15-7-0.55A	8.6	8.5	8.5	8.4	8.3	8.3	8.3	8.2	7.8	7.4	7	6.3	5.8	4.9	4.1	3.2	2.2
Q(D)X1.5-32-0.75(A)	32.5	31.5	28.5	24.5	20	15.5	8.5	-	-	-	-	-	-	-	-	-	-
Q(D)X6-18-0.75(A)	19.5	19.2	19	18.6	18	17	16.3	15.6	13.7	11.8	9	7.5	-	-	-	-	-
Q(D)X10-16-0.75(A)	19.5	19.2	19	18.6	18	17	16.3	15.6	13.7	11.8	9	7.5	-	-	-	-	-

\* single phase only

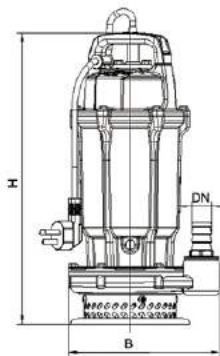

## Dimension

Model	DN	H (mm)	B (mm)
QDX1.5-12-0.25A	25	195	145
QDX1.5-15-0.37A	25	195	145
QDX1.5-25-0.55A	25	245	195
QDX3-18-0.55A	25	205	160
QDX10-10-0.55A	50	215	150
QDX15-7-0.55A	50	240	170
Q(D)X1.5-32-0.75(A)	25	245	195
Q(D)X6-18-0.75(A)	40	220	160
Q(D)X10-16-0.75(A)	40	220	160

## Hydraulic Performance Curves

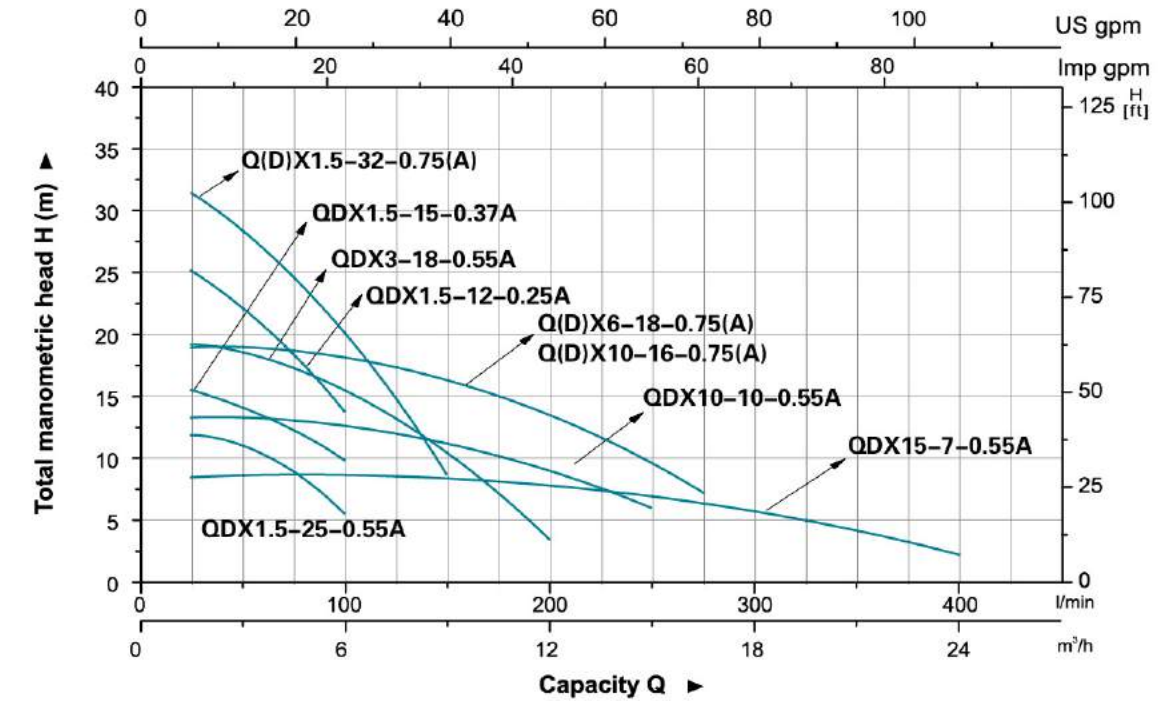

## Materials Table

No.	Part	Material
1	Handle	PP
2	Cable	
3	Top cover	HT200
4	Capacitor	
5	O-ring	NBR
6	Upper cover	HT200
7	Bearing	
8	Rotor	
9	Stator	
10	Oil injection screw	
11	Mechanical seal	Upper: Ceramic/Carbon Lower: SiC/Carbon
12	O-ring	NBR
13	Cover of oil cylinder	HT200
14	Oil seal	
15	O-ring	NBR
16	Impeller	PPD
17	Pump body	HT200
18	Filter screen	Stainless steel
19	Outlet connector	HT200

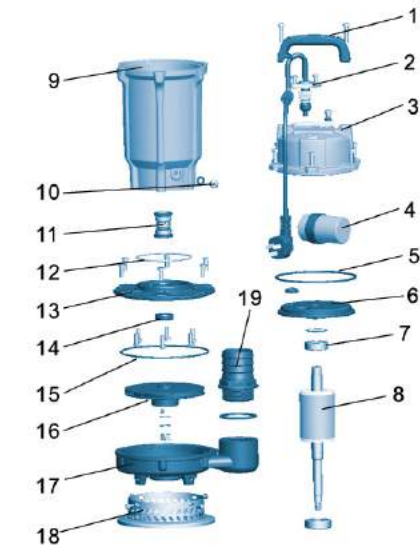

## Package Information

Model	CW (Kgs)	L (mm)	W (mm)	H (mm)	Quantity (PCS/20 TEU)
QDX1.5-12-0.25A	11.5	392	224	180	1788
QDX1.5-15-0.37A	11.5	392	224	180	1788
QDX1.5-25-0.55A	16	435	280	235	1062
QDX3-18-0.55A	14.5	415	230	205	1388
QDX10-10-0.55A	14.5	415	230	205	1388
QDX15-7-0.55A	15.5	420	280	215	1132
Q(D)X1.5-32-0.75(A)	16.5	435	250	235	1062
Q(D)X6-18-0.75(A)	15.5	415	230	205	1388
Q(D)X10-16-0.75(A)	15.5	415	230	205	1388







## Application

- Small electrical irrigation and drainage equipments
- Particularly applied in urban well water pumping, field irrigation and drainage, garden irrigation and household water supply, as well as drainage of industrial accumulated water, water supply and drainage for construction, livestock breeding, etc.

## Pump

- Cast iron pump body under special anti-rust treatment
- Max. immersion depth: 5 m
- Max. liquid temperature: +40°C
- Liquid pH value: 6.5 – 8

## Motor

- Copper winding
- Built-in thermal protector
- Stainless steel welded shaft
- Insulation class: B
- Protection class: IP68

## Identification Codes

Q(D)X 15 - 10 - 0.75 (A)

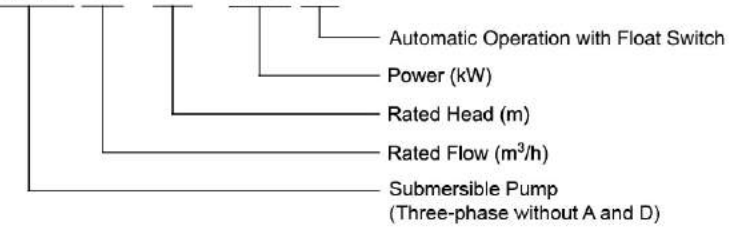

## Technical Data

Model	Q (m³/h)		Q (l/min)		H (m)																												
	0	1.5	3	4.5	6	7.5	9	10.5	12	13.5	15	16.5	18	19.5	21	22.5	24	25.5	27	28.5	30	31.5	33	34.5	36	37.5	39	40.5	42	43.5	45		
Q(D)X15-10-0.75(A)	12.1	12.1	12	11.9	11.8	11.7	11.6	11.4	11.2	10.9	10.6	10	9.5	8.9	8.2	7.7	7.2	5.7	4.9	4.2	3.4	-	-	-	-	-	-	-	-	-	-	-	-
Q(D)X25-6-0.75(A)	10.6	10.6	10.5	10.4	10.4	10.3	10.1	9.9	9.7	9.5	9.3	9	8.6	8.2	7.2	6.7	6.1	5.5	4.3	3.2	-	-	-	-	-	-	-	-	-	-	-	-	-
Q(D)X10-18-1.1(A)	25	25	25	24.6	24	22.8	22.2	18.5	16	13.2	10	-	-	-	-	-	-	-	-	-	-	-	-	-	-	-	-	-	-	-	-	-	-
Q(D)X15-14-1.1(A)	16.6	16.6	16.5	16.4	16.3	16.2	16.1	15.7	15.4	14.8	14.2	13.5	12.8	12.1	11.5	10.9	9.9	8.9	7.8	6.8	5.5	4.3	-	-	-	-	-	-	-	-	-	-	-
Q(D)X40-5.5-1.1(A)	9.5	9.5	9.5	9.5	9.5	9.5	9.5	9.5	9.5	9.5	9.5	9.5	9.4	9.3	9.2	9	8.9	8.7	8.3	8	7.7	7.3	6.9	6.5	6	5.5	5	4.5	4	3.5	3	-	

## Hydraulic Performance Curves

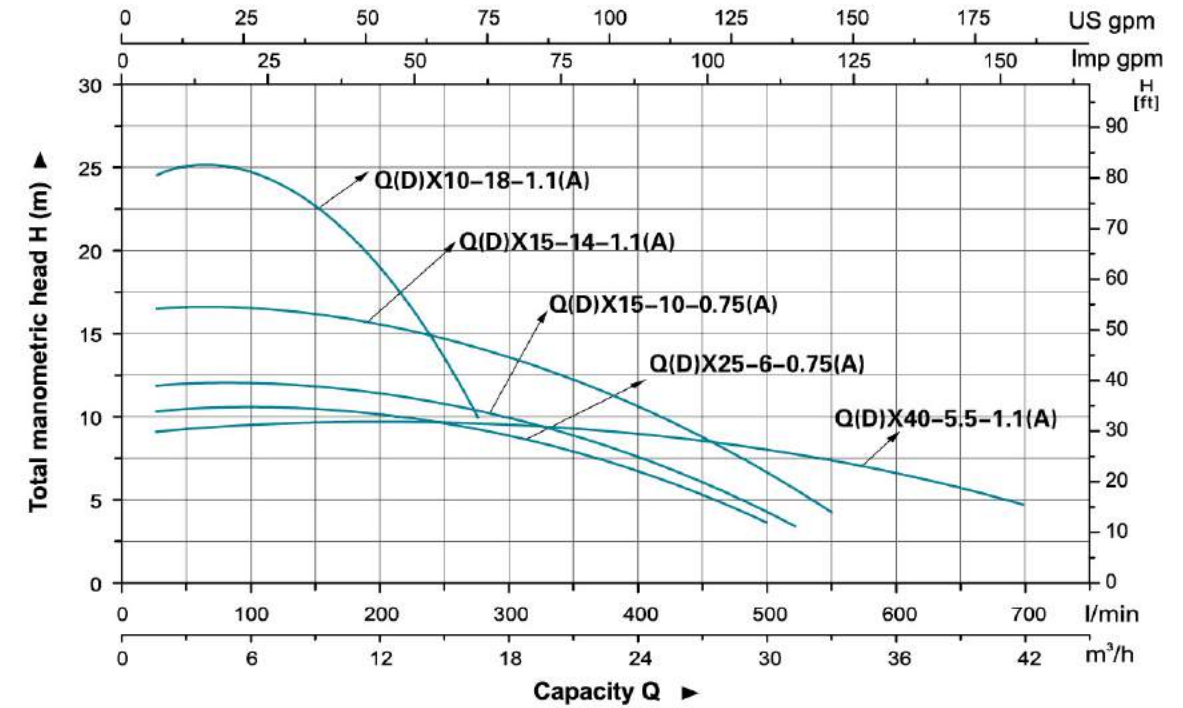

## Materials Table

No.	Part	Material
1	Handle	PP
2	Cable	
3	Top cover	HT200
4	Capacitor	
5	O-ring	NBR
6	Upper cover	HT200
7	Bearing	
8	Rotor	
9	Stator	
10	Oil injection screw	
11	Mechanical seal	Upper: Ceramic/Carbon Lower: SiC/Carbon
12	O-ring	NBR
13	Cover of oil cylinder	HT200
14	Oil seal	
15	O-ring	NBR
*16	Impeller	PPD HT200
17	Pump body	HT200
18	Filter screen	Stainless steel
19	Outlet connector	HT200

\*HT200 for QDX25-6-0.75A and QDX40-5.5-1.1A

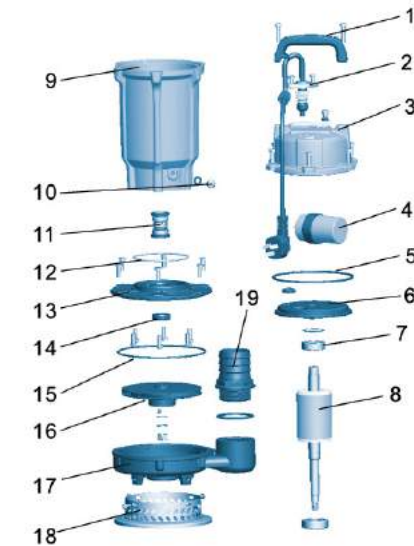

## Dimension

Model	DN	H (mm)	B (mm)
Q(D)X15-10-0.75(A)	50	240	170
Q(D)X25-6-0.75(A)	65	250	160
Q(D)X10-18-1.1(A)	50	270	190
Q(D)X15-14-1.1(A)	65	270	180
Q(D)X40-5.5-1.1(A)	80	270	195

## Package Information

Model	GW (Kgs)	L (mm)	W (mm)	H (mm)	Quantity (PCS/20' TEU)
Q(D)X15-10-0.75(A)	16.5	420	280	215	1132
Q(D)X25-6-0.75(A)	17.5	420	280	215	1132
Q(D)X10-18-1.1(A)	22	452	300	240	855
Q(D)X15-14-1.1(A)	22	452	300	240	855
Q(D)X40-5.5-1.1(A)	22.5	490	295	235	792





## Application

- Small electrical irrigation and drainage equipments
- Particularly applied in urban well water pumping, field irrigation and drainage, garden irrigation and household water supply, as well as drainage of industrial accumulated water, water supply and drainage for construction, livestock breeding, etc.

## Pump

- Stainless steel pump body
- Max. immersion depth: 5 m
- Max. liquid temperature: +40°C
- Liquid pH value: 4 – 10
- Max. liquid density: 1.03x10<sup>3</sup>kg/m<sup>3</sup>

## Motor

- Copper winding
- Built-in thermal protector
- Stainless steel welded shaft
- Insulation class: B
- Protection class: IP68

## Identification Codes

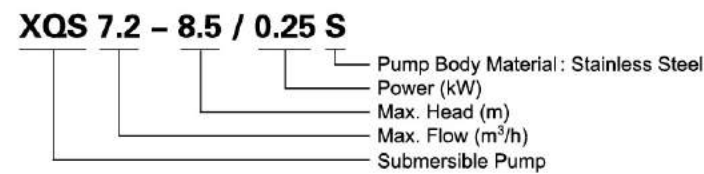

## Hydraulic Performance Curves

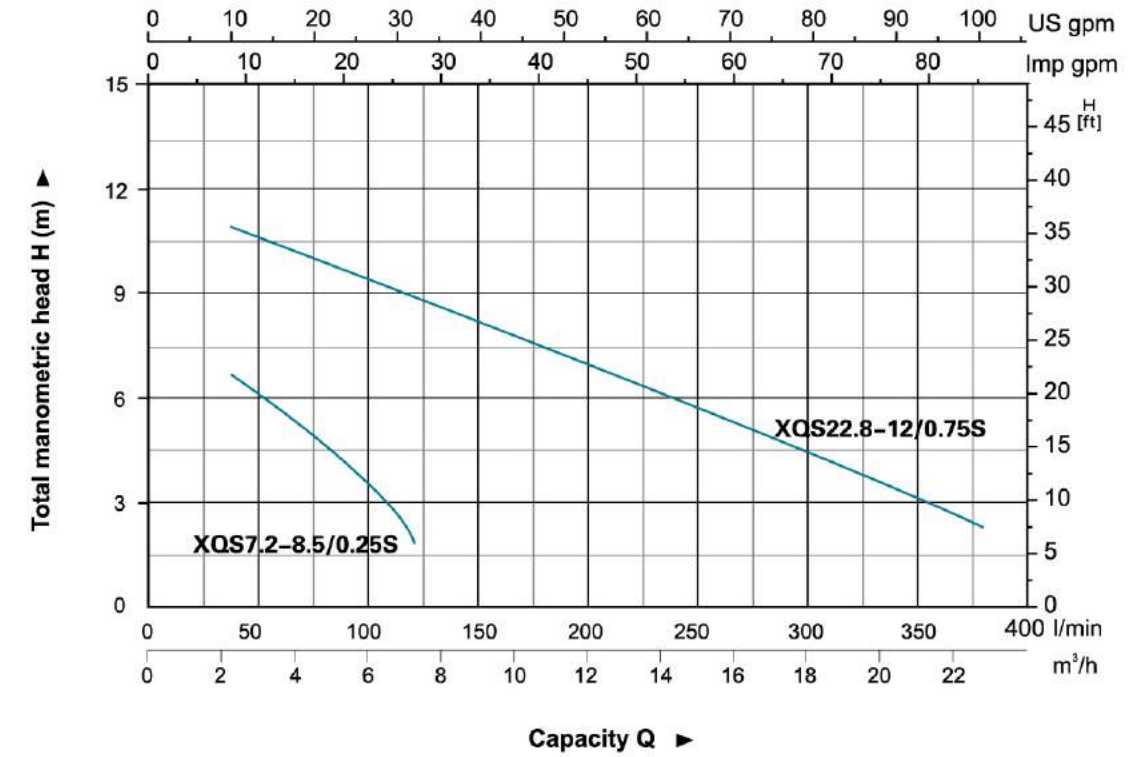

## Technical Data

Model	Power		Outlet diameter (mm)	Voltage (V/Hz)	Max. flow (l/min)	Max. head (m)	GW (kgs)	Packing size (mm)	Quantity (PCS/20 TEU)
	(kW)	HP							
XQS7.2-8.5/0.25S	0.25	0.33	40,32,25	220/50	120	8.5	10.2	175x175x360	2131
XQS22.8-12/0.75S	0.75	1.0	50	220/50	380	12	19.2	220x220x440	1132

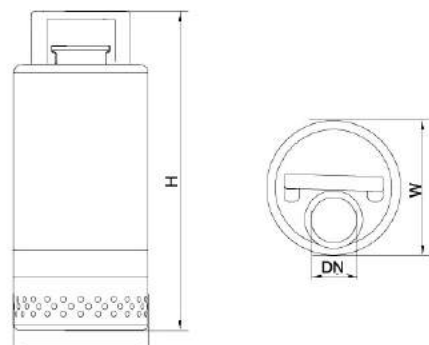

## Dimension

Model	DN	L (mm)	W (mm)	H (mm)
XQS7.2-8.5/0.25S	1 1/4"	142	142	300
XQS22.8-12/0.75S	2"	170	170	380

## Materials Table

No.	Part	Material	No.	Part	Material
1	Handle	Stainless steel	27	Stretching washer	65Mn
2	Screw	Stainless steel	28	Washer	CuZn40
3	Nut	Stainless steel	29	Motor cover	Stainless steel
4	Protector	FKM	30	Thermal protector	
5	Cable presser	Stainless steel	31	O-ring	FKM
6	Screw	Stainless steel	32	Stator	
7	Flange	Stainless steel	33	Wave washer	65Mn
8	Cable		34	Ball bearing	
9	Cable protector	CR	35	Rotor	
10	Connector	ABS	36	Connection part	Stainless steel
11	O-ring	FKM	37	O-ring	FKM
12	Motor shell	Stainless steel	38	O-ring	FKM
13	Rubber washer	FKM	39	Oil chamber cover	Stainless steel
14	Washer	Steel	40	Mechanical seal	SiC/SiC
15	Stretching washer	Stainless steel	41	O-ring	FKM
16	Washer	Stainless steel	42	Pump body	Stainless steel
17	Screw	Stainless steel	43	Screw	Stainless steel
18	O-ring	FKM	44	Oil seal	
19	Rubber washer	FKM	45	Impeller	Stainless steel
20	Capacitor cover	Stainless steel	46	Screw	Stainless steel
21	Bolt	Stainless steel	47	Nut	Stainless steel
22	Capacitor		48	Rubber washer	FKM
23	Screw	Stainless steel	49	Screw	Stainless steel
24	O-ring	FKM	50	Screw	Stainless steel
25	Cable holder	NBR	51	Filter mesh	Stainless steel
26	Screw	CuZn40			

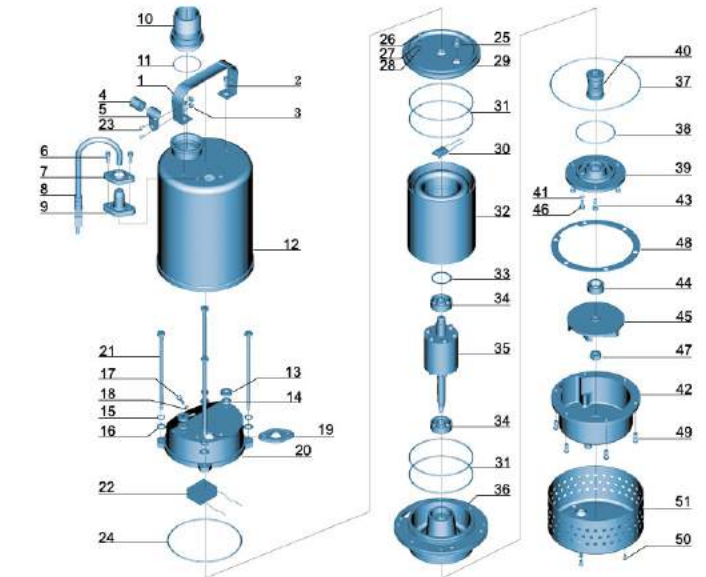





### Application

- Small electrical irrigation and drainage equipments
- Particularly applied in urban well water pumping, field irrigation and drainage, garden irrigation and household water supply, as well as drainage of industrial accumulated water, water supply and drainage for construction, livestock breeding, etc.

### Pump

- Max. immersion depth: 5 m
- Max. liquid temperature: +40°C
- Liquid pH value: 6.5 – 8

### Motor

- Copper winding
- Built-in thermal protector
- Stainless steel welded shaft
- Insulation class: B
- Protection class: IP68

### Identification Codes

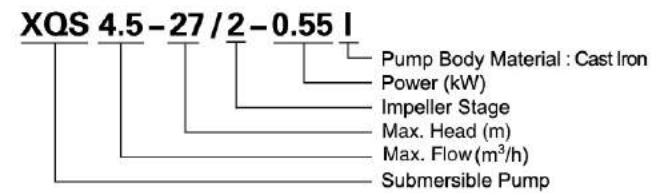

### Hydraulic Performance Curves

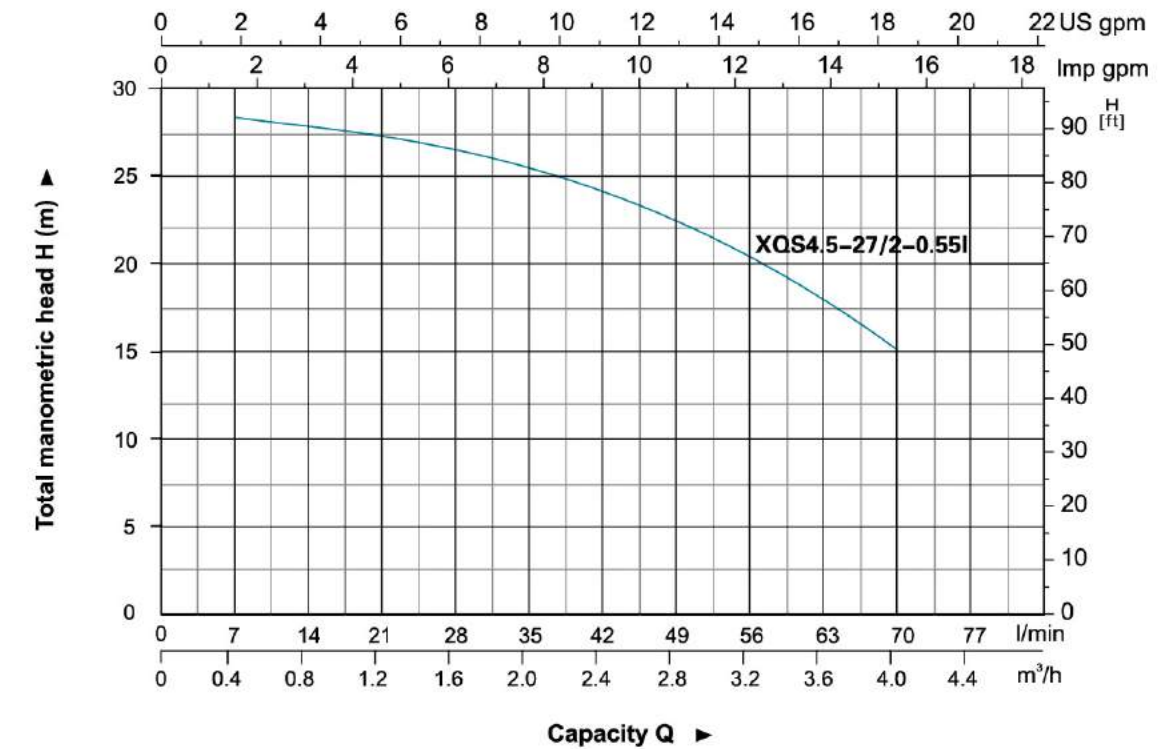

### Technical Data

Model	Power		Outlet diameter (mm)	Voltage (V/Hz)	Max.flow (l/min)	Max.head (m)	GW (kgs)	Packing size (mm)	Quantity (PCS/20 TEU)
	(kW)	HP							
XQS4.5-27/2-0.55I	0.55	0.75	25	220/50	75	27	21.8	500x270x235	980

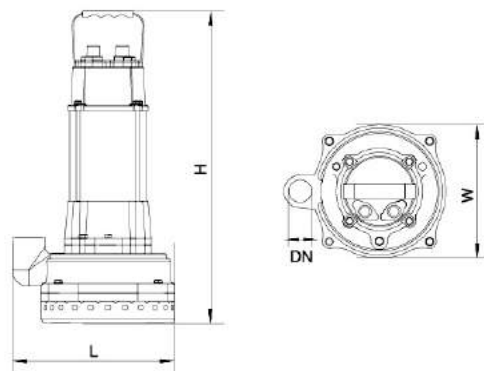

### Dimension

Model	DN	L (mm)	W (mm)	H (mm)
XQS4.5-27/2-0.55I	1"	235	198	462

### Materials Table

No.	Part	Material	No.	Part	Material
1	Bolt	Stainless steel	33	Ball bearing	
2	Stretching washer	Stainless steel	34	Bolt	Stainless steel
3	Washer	Stainless steel	35	Washer	Stainless steel
4	Bolt	Stainless steel	36	Connection part	HT200
5	Washer	Stainless steel	37	Mechanical seal	Carbon/Ceramic
6	Handle	Stainless steel	38	O-ring	NBR
7	Nut	Stainless steel	39	Oil chamber cover	HT200
8	Protector	NR	40	Screw	Stainless steel
9	Cable presser	Stainless steel	41	Washer	Stainless steel
10	Washer	Stainless steel	42	O-ring	Stainless steel
11	Screw	Stainless steel	43	Screw	Stainless steel
12	Bolt	Stainless steel	44	Bolt	Stainless steel
13	O-ring	NBR	45	Washer	Stainless steel
14	Bolt	Stainless steel	46	Connector	ABS
15	Flange	Stainless steel	47	O-ring	NBR
16	Cable		48	Pump body	HT200
17	Cable protector	CR	49	Mechanical seal	Ceramic/Carbon
18	Capacitor cover	HT200	50	Impeller	PPO
19	Capacitor		51	Guidleaf cover	PPO
20	O-ring	NBR	52	Guidleaf	PPO
21	O-ring	NBR	53	Sleeve	PPO
22	Screw	CuZn40	54	O-ring	NBR
23	Stretching washer	65Mn	55	Washer	Stainless steel
24	Washer	CuZn40	56	Stretching washer	Stainless steel
25	Cable holder	NBR	57	Nut	Stainless steel
26	Motor cover	HT200	58	O-ring	NBR
27	Thermal protector		59	Pump cover	HT200
28	Stator		60	Nut	
29	O-ring	NBR	61	Bilateral bolt	Stainless steel
30	Wave washer	65Mn	62	Filter mesh	Stainless steel
31	Ball bearing		63	Float switch	
32	Rotor				

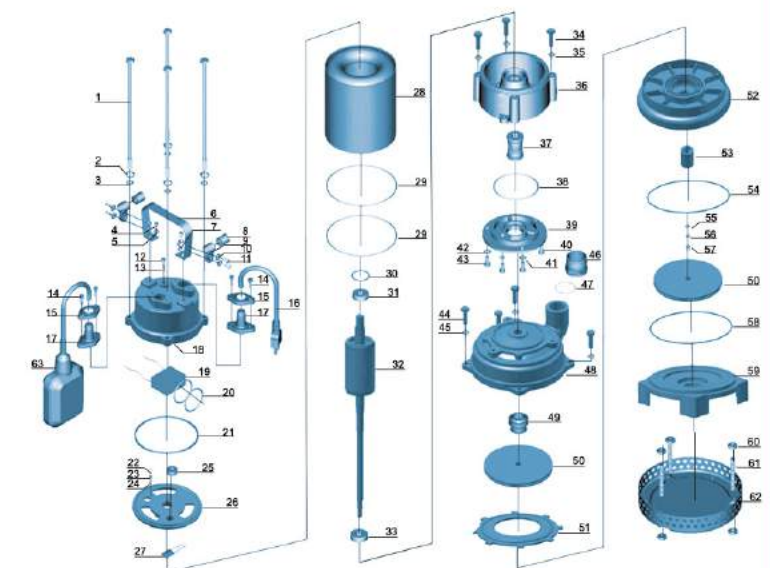





## Application

- Small electrical irrigation and drainage equipments
- Particularly applied in urban well water pumping, field irrigation and drainage, garden irrigation and household water supply, as well as drainage of industrial accumulated water, water supply and drainage for construction, livestock breeding, etc.

## Pump

- Max. immersion depth: 5 m
- Max. liquid temperature: +40°C
- Liquid pH value: 6.5 – 8

## Motor

- Copper winding
- Built-in thermal protector
- Stainless steel welded shaft
- Insulation class: B
- Protection class: IP68

## Identification Codes

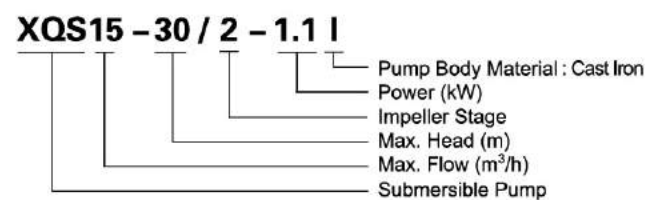

## Hydraulic Performance Curves

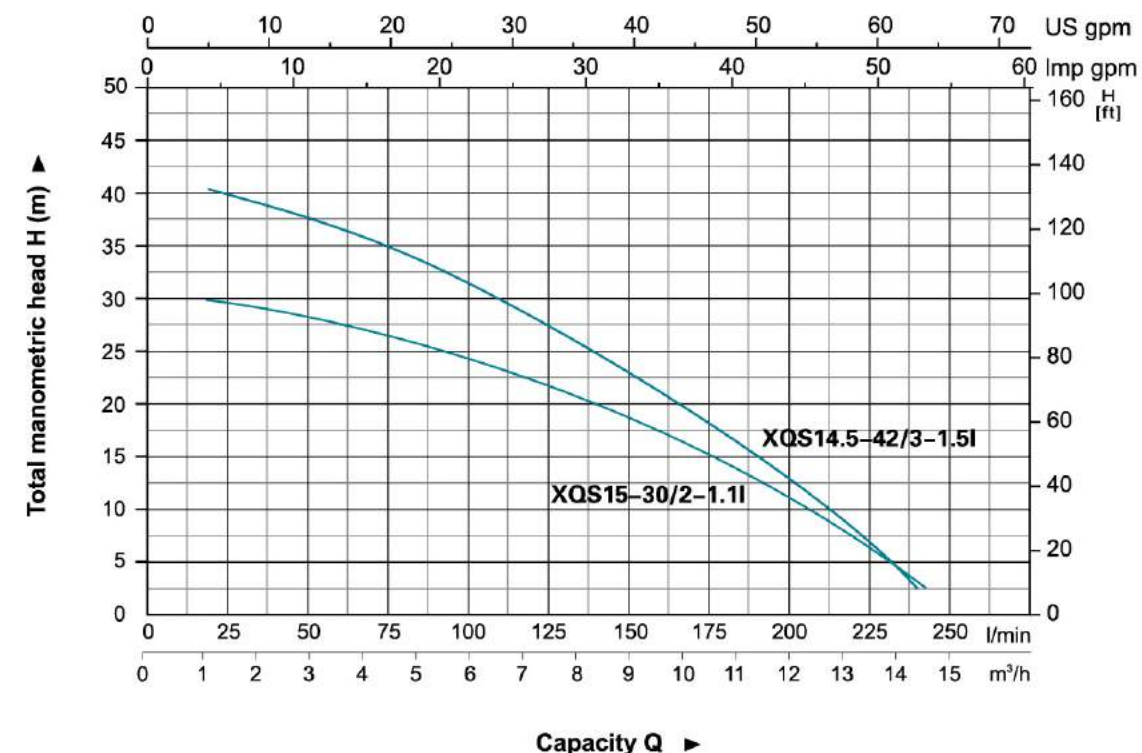

## Technical Data

Model	Power		Outlet diameter (mm)	Voltage (V/Hz)	Max. flow (l/min)	Max. head (m)	GW (kgs)	Packing size (mm)	Quantity (PCS/20 TEU)
	(kW)	HP							
XQS15-30/2-1.1I	1.1	1.5	50	220/50	250	30	23.3	555x290x220	840
XQS14.5-42/3-1.5I	1.5	2.0	50	220/50	240	42	26.8	625x285x205	614

## Materials Table

No.	Part	Material	No.	Part	Material
1	Bolt	Stainless steel	29	Stator	
2	Stretching washer	Stainless steel	30	Wave washer	65Mn
3	Washer	Stainless steel	31	Ball bearing	
4	Bolt	Stainless steel	32	Rotor	
5	Washer	Stainless steel	33	Ball bearing	
6	Handle	Stainless steel	34	Connection part	HT200
7	Nut	Stainless steel	35	Mechanical seal	Ceramic/Carbon
8	Protector	NBR	36	O-ring	NBR
9	Cable presser	Stainless steel	37	Connector	ABS
10	Washer	Stainless steel	38	O-ring	NBR
11	Screw	Stainless steel	39	Pump body	HT200
12	Bolt	Stainless steel	40	Screw	Stainless steel
13	O-ring	NBR	41	Oil seal	
14	Screw	Stainless steel	42	Rubber washer	NBR
15	Flange	Stainless steel	43	Impeller	HT200
16	Cable		44	Ring	Steel
17	Cable protector	CR	45	O-ring	NBR
18	Capacitor cover	HT200	46	Diffuser	HT200
19	Capacitor		47	Stretching washer	Stainless steel
20	O-ring	NBR	48	Screw	Stainless steel
21	Rubber washer	NBR	49	Nut	Stainless steel
22	Screw	CuZn40	50	Pump cover	HT200
23	Stretching washer	65Mn	51	Washer	Stainless steel
24	Washer	CuZn40	52	Screw	Stainless steel
25	Cable holder	NBR	53	Filter mesh	Steel
26	Motor cover	HT200	54	Float switch	
27	Thermal protector		55	Key	Steel
28	O-ring	NBR			

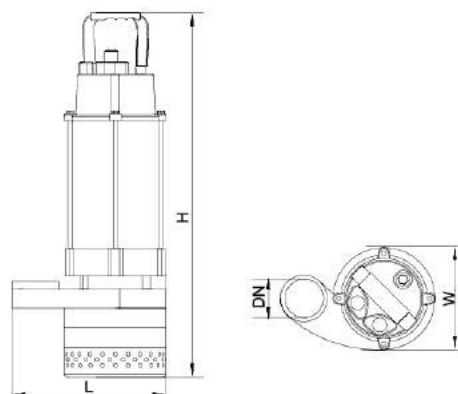
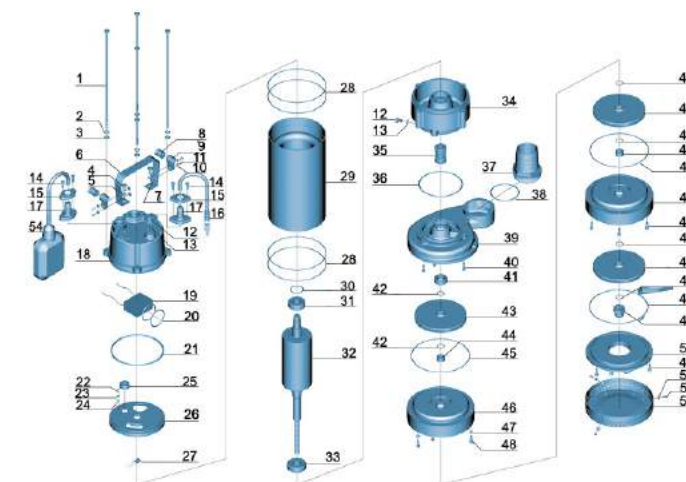

## Dimension

Model	DN	L (mm)	W (mm)	H (mm)
XQS15-30/2-1.1I	2"	232	152	508
XQS14.5-42/3-1.5I		232	152	567





### Application

- Small electrical irrigation and drainage equipments
- Particularly applied in urban well water pumping, field irrigation and drainage, garden irrigation and household water supply, as well as drainage of industrial accumulated water, water supply and drainage for construction, livestock breeding, etc.

### Pump

- Max. immersion depth: 5 m
- Max. liquid temperature: +40°C
- Liquid pH value: 6.5 – 8

### Motor

- Copper winding
- Built-in thermal protector
- Stainless steel welded shaft
- Insulation class: B
- Protection class: IP68

### Identification Codes

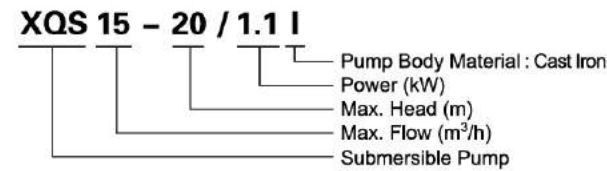

### Hydraulic Performance Curves

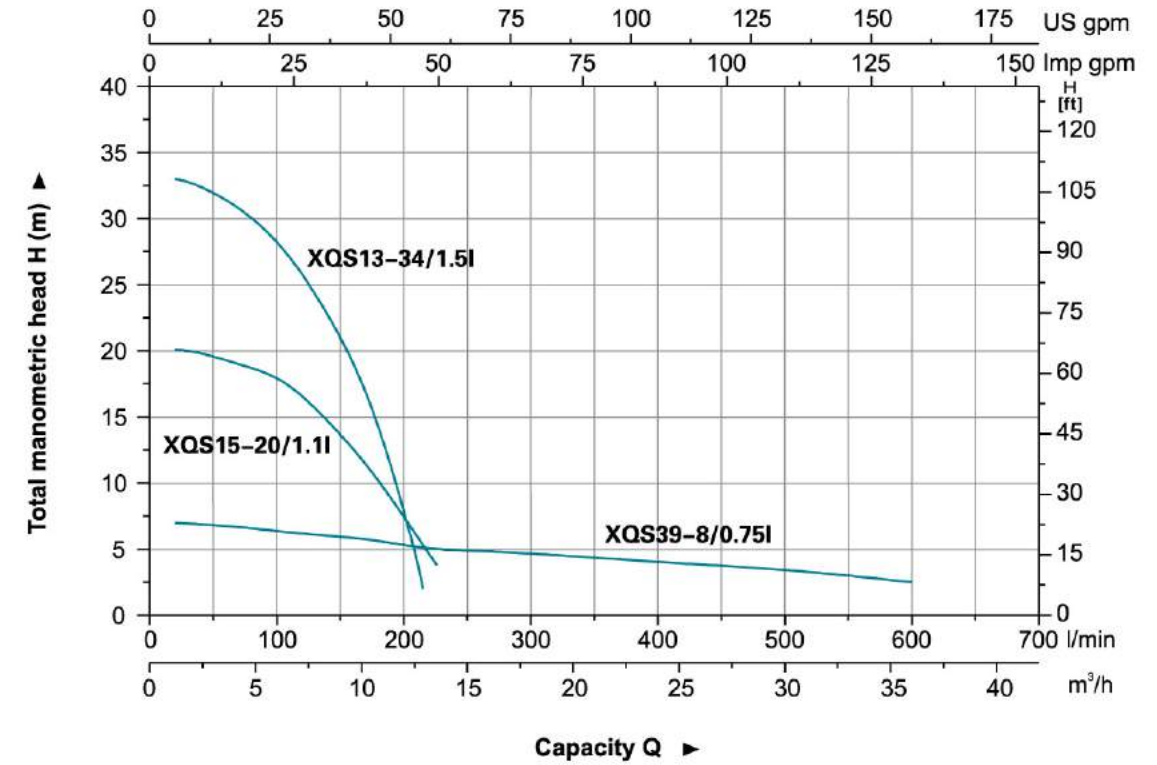

### Technical Data

Model	Power		Outlet diameter (mm)	Voltage (V/Hz)	Max. flow (l/min)	Max. head (m)	GW (kgs)	Packing size (mm)	Quantity (PCS/20 TEU)
	(kW)	HP							
XQS39-8/0.75I	0.75	1.0	75	220/50	650	8	21.6	580x320x250	684
XQS15-20/1.1I	1.1	1.5	40,32,25	220/50	250	20	21.5	510x290x220	880
XQS13-34/1.5I	1.5	2.0	40,32,25	220/50	216	34	25.3	580x320x250	648

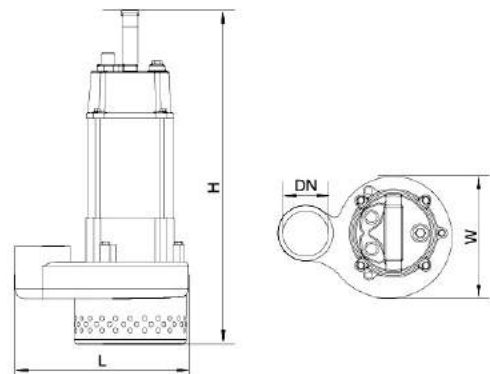

### Dimension

Model	DN	L (mm)	W (mm)	H (mm)
XQS39-8/0.75I	2 1/2"	207	109	500
XQS15-20/1.1I	1 1/4"	238	177	460
XQS13-34/1.5I		250	205	512

### Materials Table

No.	Part	Material	No.	Part	Material
1	Bolt	Stainless steel	26	Thermal protector	
2	Stretching washer	Stainless steel	27	O-ring	NBR
3	Washer	Stainless steel	28	Stator	
4	Bolt	Stainless steel	29	Wave washer	65Mn
5	Washer	Stainless steel	30	Ball bearing	
6	Handle	Stainless steel	31	Rotor	
7	Nut	Stainless steel	32	Ball bearing	
8	Protector	NR	33	Lower cover	HT200
9	Cable presser	Stainless steel	34	Oil seal	
10	Washer	Stainless steel	35	Connector	ABS
11	Screw	Stainless steel	36	O-ring	NBR
12	Bolt	Stainless steel	37	Pump body	HT200
13	O-ring	NBR	38	Mechanical seal	Ceramic/Carbon
14	Screw	Stainless steel	39	Impeller	HT200
15	Flange	Stainless steel	40	Nut	Stainless steel
16	Cable		41	O-ring	NBR
17	Cable protector	CR	42	Pump body	HT200
18	Capacitor cover	HT200	43	Washer	Stainless steel
19	Capacitor		44	Screw	Stainless steel
20	O-ring	NBR	45	Filter mesh	Steel
21	Cable holder	NBR	46	Washer	Stainless steel
22	Screw	CuZn40	47	Screw	Stainless steel
23	Stretching washer	65Mn	48	Stretching washer	Stainless steel
24	Washer	CuZn40	49	Float switch	
25	Upper cover	HT200			

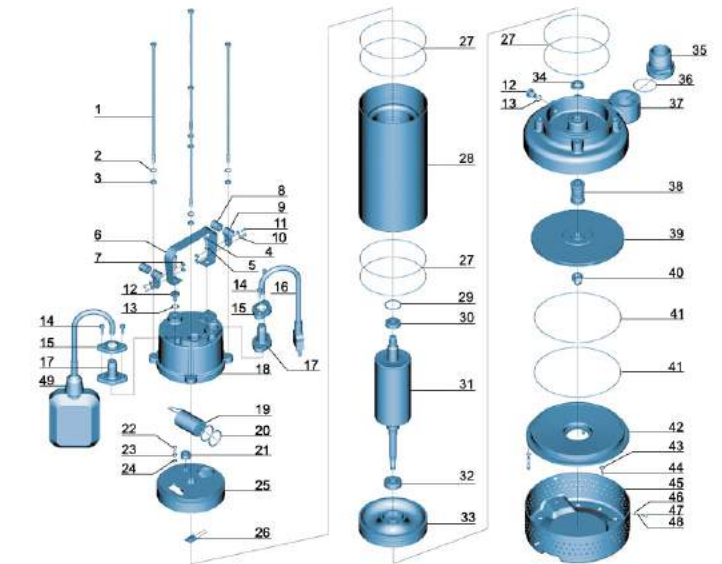





### Application

- Wastewater drainage in factories, construction sites and commercial facilities
- Drainage system in municipal sewage treatment plants
- Drainage station in residential quarters
- Municipal projects
- Methane pools and field irrigation in countryside

### Pump

- Max. immersion depth: 5 m
- Max. liquid temperature: +40°C
- Liquid pH value: 4 – 10
- Liquid kinematic viscosity:  $7 \times 10^{-7} - 23 \times 10^{-6} \text{ m}^2/\text{s}$
- Max. liquid density:  $1.2 \times 10^3 \text{ kg/m}^3$

### Motor

- Copper winding
- Built-in thermal protector
- Stainless steel welded shaft
- Insulation class: B
- Protection class: IP68

### Identification Codes

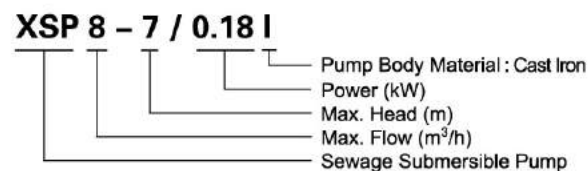

### Hydraulic Performance Curves

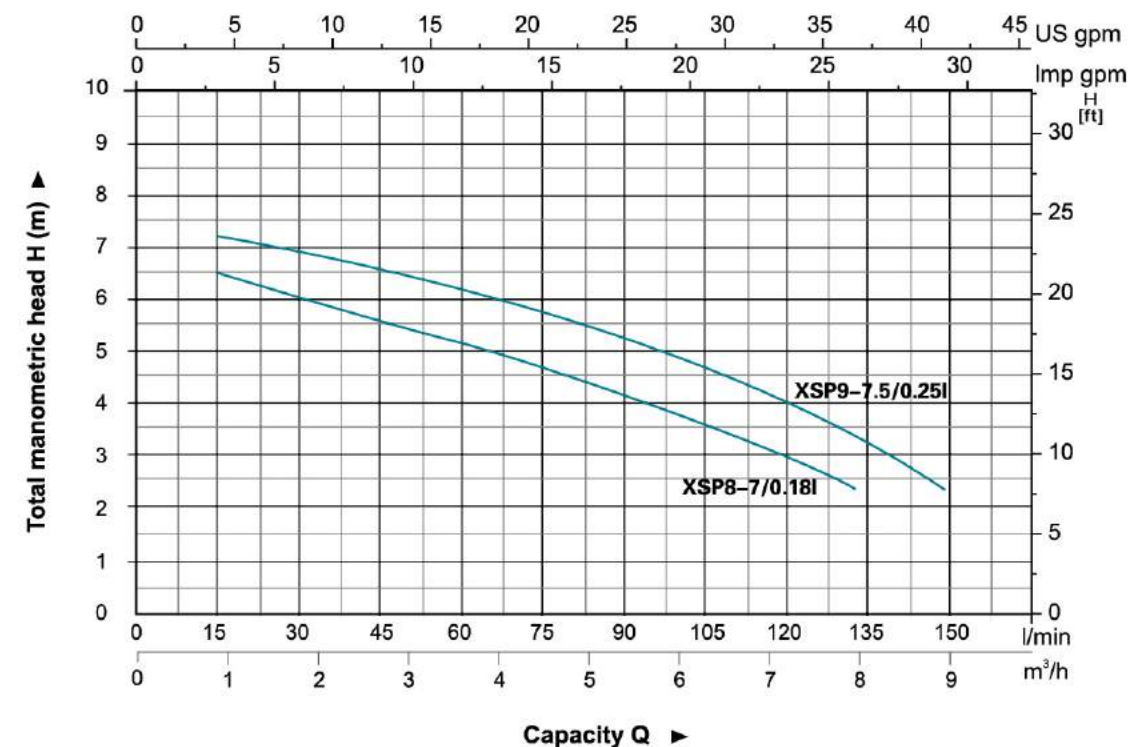

### Technical Data

Model	Power		Outlet diameter (mm)	Voltage (V/Hz)	Max. flow (l/min)	Max. head (m)	Max. dia. of particle (mm)	GW (kgs)	Packing size (mm)	Quantity (PCS/20' TEU)
	(kW)	HP								
XSP8-7/0.18I	0.18	0.25	40,32,25	220/50	133	7	15	9	185x180x360	2322
XSP9-7.5/0.25I	0.25	0.33	40,32,25	220/50	150	7.5	15	10	185x180x380	2174

### Materials Table

No.	Part	Material	No.	Part	Material
1	Bolt	Stainless steel	25	Stator	
2	Stretching washer	Stainless steel	26	Screw	Stainless steel
3	Washer	Stainless steel	27	Stretching washer	Stainless steel
4	Handle	Stainless steel	28	Thermal protector	
5	Screw	Stainless steel	29	Wave washer	65Mn
6	Cable		30	Ball bearing	
7	Flange	Stainless steel	31	Rotor	
8	Cable protector	CR	32	Ball bearing	
9	Capacitor cover	HT200	33	Rubber washer	NBR
10	Screw	Stainless steel	34	Screw	Stainless steel
11	Cable presser	Stainless steel	35	O-ring	NBR
12	Protector	NR	36	Connection part	HT200
13	O-ring	NBR	37	Mechanical seal	Ceramic/Carbon
14	Capacitor		38	O-ring	NBR
15	Rubber washer	NBR	39	Oil chamber cover	HT200
16	Screw	Steel	40	Washer	Stainless steel
17	Stretching washer	65Mn	41	Screw	Stainless steel
18	Washer	Steel	42	Oil seal	
19	Press plate	Steel	43	Impeller	PA66
20	Cable holder	NBR	44	Nut	Stainless steel
21	Screw	CuZn40	45	Connector	ABS
22	Stretching washer	65Mn	46	O-ring	NBR
23	Washer	CuZn40	47	Pump body	HT200
24	Nut	Stainless steel	48	Float switch	

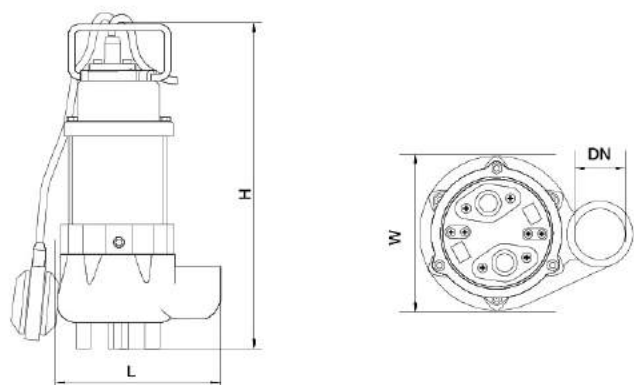
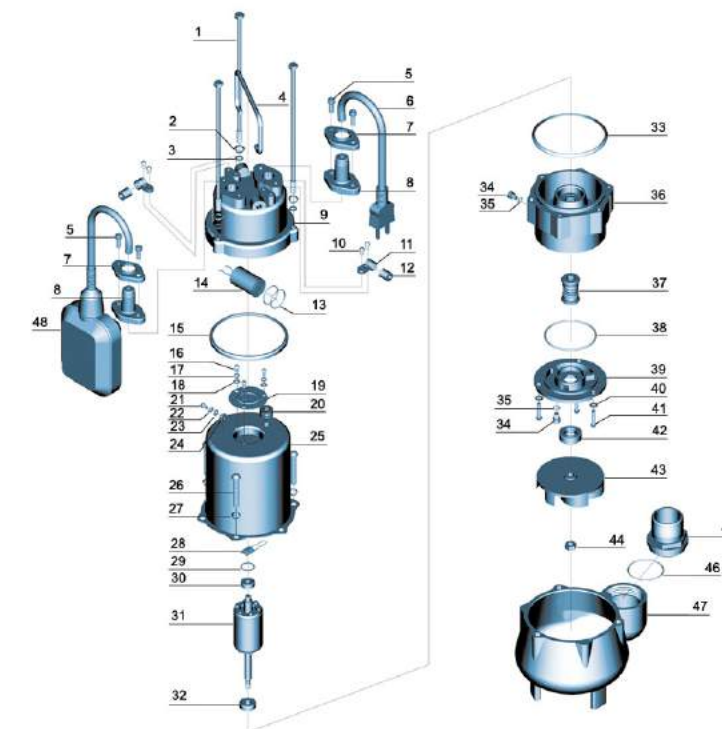

### Dimension

Model	DN	L (mm)	W (mm)	H (mm)
XSP8-7/0.18I	1 1/4"	166	121	335
XSP9-7.5/0.25I		166	121	355





### Application

- Wastewater drainage in factories, construction sites and commercial facilities
- Drainage system in municipal sewage treatment plants
- Drainage station in residential quarters
- Municipal projects
- Methane pools and field irrigation in countryside

### Pump

- Max. immersion depth: 5 m
- Max. liquid temperature: +40°C
- Liquid pH value: 4 – 10
- Liquid kinematic viscosity:  $7 \times 10^{-7} \sim 23 \times 10^{-6} \text{ m}^2/\text{s}$
- Max. liquid density:  $1.2 \times 10^3 \text{ kg/m}^3$

### Motor

- Copper winding
- Built-in thermal protector
- Stainless steel welded shaft
- Insulation class: B
- Protection class: IP68

### Identification Codes

**XSP 32 - 17 / 1.5 I**

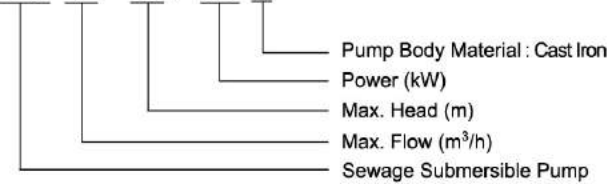

### Technical Data

Model	Power		Outlet diameter (mm)	Voltage (V/Hz)	Max. flow (l/min)	Max. head (m)	Max. dia. of particle (mm)	GW (kgs)	Packing size (mm)
	(kW)	HP							
XSP32-17/1.5I	1.5	2	50	220/50	530	17	25	29	610x315x255

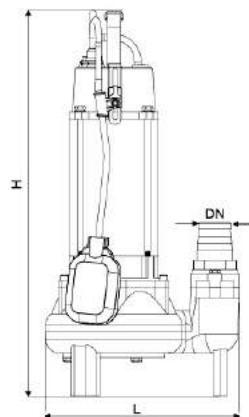

### Dimension

Model	DN	L (mm)	H (mm)
XSP32-17/1.5I	2	288	571

### Hydraulic Performance Curves

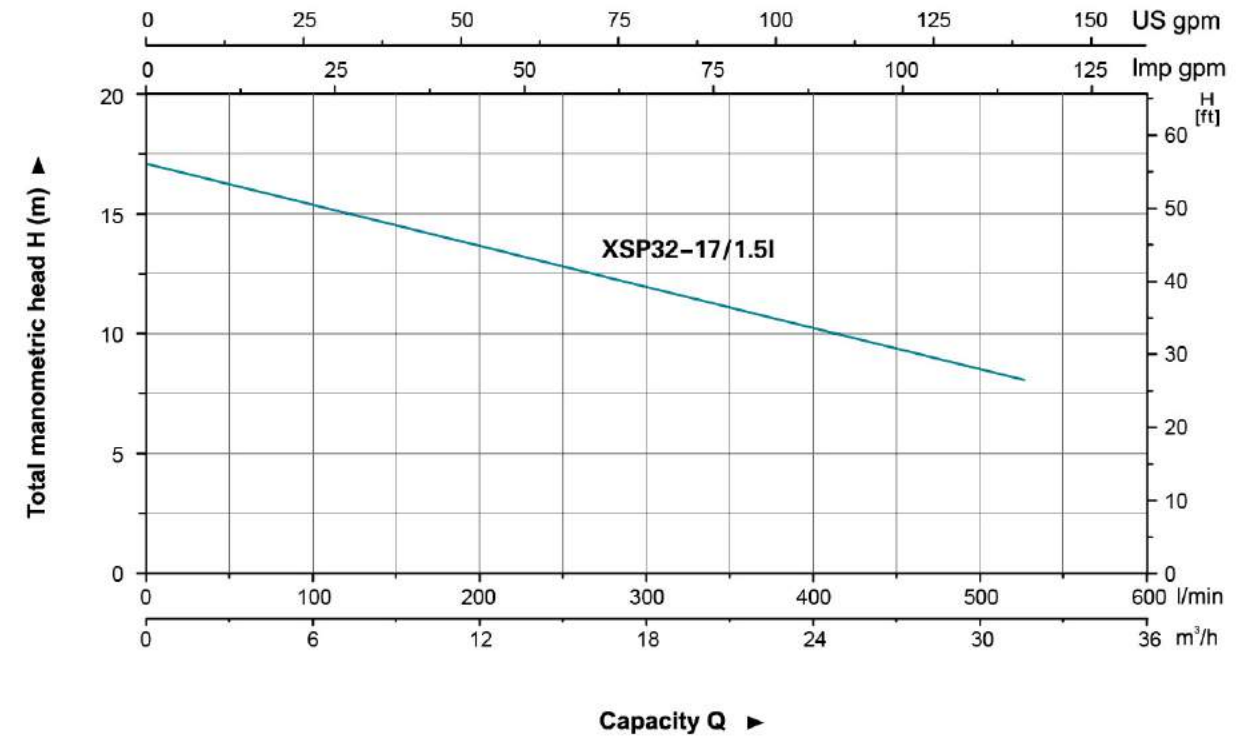

### Materials Table

No.	Part	Material	No.	Part	Material
1	Handle	Stainless steel	29	Screw	CuZn40
2	Bolt	Stainless steel	30	Serrated lock washer	Stainless steel
3	Washer	Stainless steel	31	Washer	Stainless steel
4	Boit	Stainless steel	32	Motor cover	HT200
5	Spring washer	Stainless steel	33	Motor protector	
6	Washer	2Cr13 (Stabdar) AISI304/AISI316 ASTM1045	34	Motor	
7	Screw	Stainless steel	35	Motor casing	Stainless steel
8	O-ring	NBR	36	Undulated washer	
9	Float switch		37	Upper bearing	
10	Screw	Stainless steel	38	Rotor	
11	Flange	2Cr13 (Stabdar) AISI304/AISI316 ASTM1045	39	Circlip	
12	Cable protector	CR	40	Lower bearing	
13	Guide support	Stainless steel	41	Key	Stainless steel
14	Screw	Stainless steel	42	Screw	Stainless steel
15	Washer	Stainless steel	43	Connection part	HT200
16	Clamp	PA66+GF	44	O-ring	NBR
17	Adjustable bracket	PA66+GF	45	Mechanical seal	Graphite/Ceramic
18	Cable		46	O-ring	NBR
19	Cable presser	Stainless steel	47	Oil chamber cover	HT200
20	Protector	NR	48	Oil seal	
21	Screw	Stainless steel	49	Impeller	Cast Iron
22	Nut	Stainless steel	50	Washer	Stainless steel
23	Capacitor cover	HT200	51	Spring washer	Stainless steel
24	O-ring	NBR	52	Nut	Stainless steel
25	O-ring	NBR	53	Pump body	HT200
26	Capacitor		54	Pump cover	Cast Iron
27	Gasket	NBR	55	Bolt	Stainless steel
28	Line protector	NBR	56	Discharge	ABS
			57	O-ring	NBR
			58	Bolt	Stainless steel
			59	Connection nut	HT200
			60	Gasket	NBR

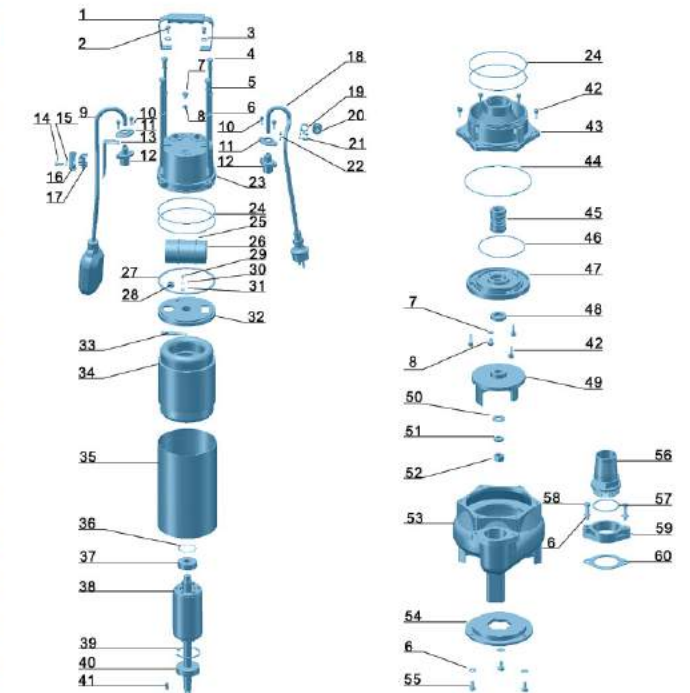





### Application

- Wastewater drainage in factories, construction sites and commercial facilities
- Drainage system in municipal sewage treatment plants
- Drainage station in residential quarters
- Municipal projects
- Methane pools and field irrigation in countryside

### Pump

- Max. immersion depth: 5 m
- Max. liquid temperature: +40°C
- Liquid pH value: 4 – 10
- Liquid kinematic viscosity:  $7 \times 10^{-7} \sim 23 \times 10^{-6} \text{ m}^2/\text{s}$
- Max. liquid density:  $1.2 \times 10^3 \text{ kg/m}^3$

### Motor

- Copper winding
- Built-in thermal protector
- Stainless steel welded shaft
- Insulation class: B
- Protection class: IP68

### Identification Codes

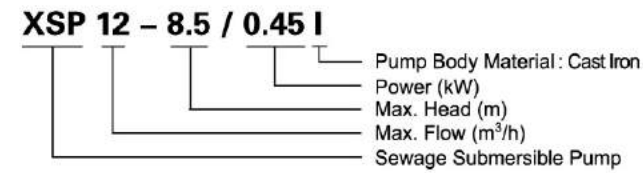

### Hydraulic Performance Curves

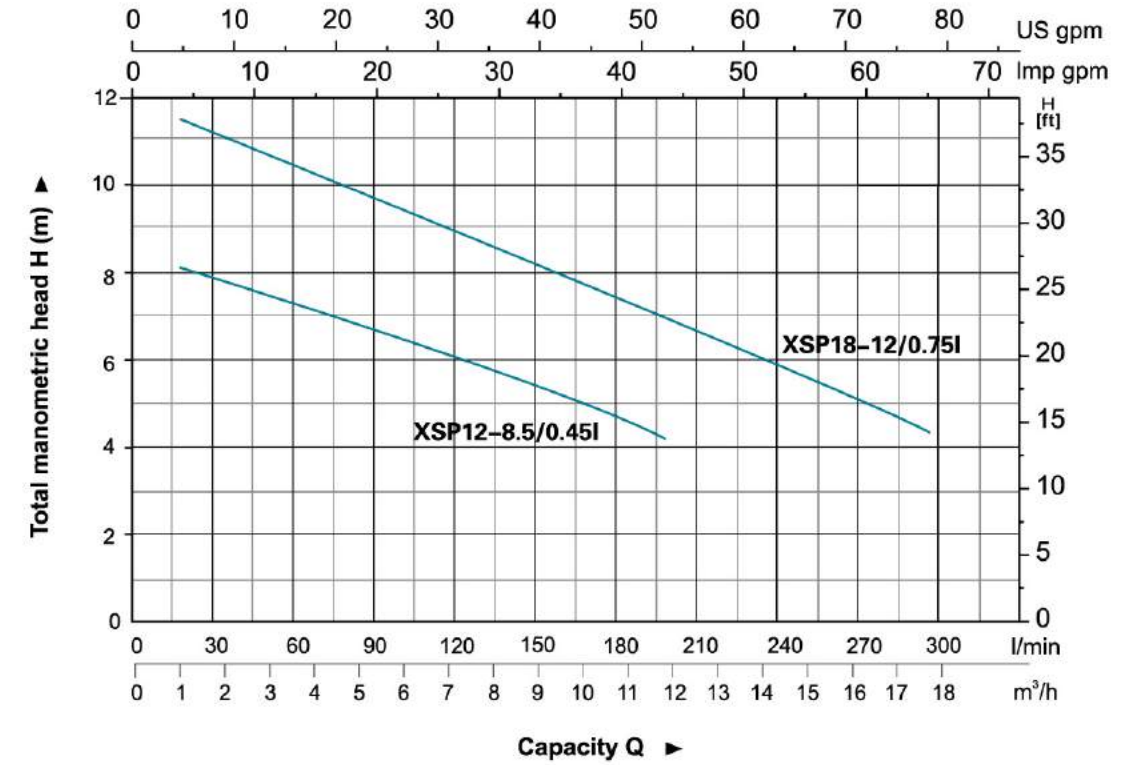

### Technical Data

Model	Power		Outlet diameter (mm)	Voltage (V/Hz)	Max. flow (l/min)	Max. head (m)	Max. dia. of particle (mm)	GW (kgs)	Packing size (mm)	Quantity (PCS/20 TEU)
	(kW)	HP								
XSP12-8.5/0.45I	0.45	0.6	50	220/50	200	8.5	25	18.2	495x263x222	1010
XSP18-12/0.75I	0.75	1.0	50	220/50	300	12	25	20.2	540x265x195	1056

### Materials Table

No.	Part	Material	No.	Part	Material
1	Bolt	Stainless steel	30	Wave washer	65Mn
2	Stretching washer	Stainless steel	31	Ball bearing	
3	Washer	Stainless steel	32	Rotor	
4	Bolt	Stainless steel	33	Ball bearing	
5	Washer	Stainless steel	34	Screw	Stainless steel
6	Handle	Stainless steel	35	Washer	Stainless steel
7	Nut	Stainless steel	36	Connection part	HT200
8	Protector	NR	37	Mechanical seal	Ceramic/Carbon
9	Cable presser	Stainless steel	38	O-ring	NBR
10	Washer	Stainless steel	39	Oil chamber cover	HT200
11	Screw	Stainless steel	40	Screw	Stainless steel
12	Bolt	Stainless steel	41	Washer	Stainless steel
13	O-ring	NBR	42	O-ring	NBR
14	Screw	Stainless steel	43	Screw	Stainless steel
15	Flange	Stainless steel	44	Oil seal	
16	Cable		45	Impeller	HT200
17	Cable protector	CR	46	Nut	Stainless steel
18	Capacitor cover	HT200	47	Bolt	Stainless steel
19	Capacitor		48	Washer	Stainless steel
20	O-ring	NBR	49	Connector	ABS
21	Rubber washer	NBR	50	O-ring	NBR
22	Screw	CuZn40	51	Connector nut	HT200
23	Stretching washer	65Mn	52	Rubber washer	NBR
24	Washer	CuZn40	53	Pump body	HT200
25	Cable holder	NBR	54	Base plate	HT200
26	Motor cover	HT200	55	Washer	Stainless steel
27	Thermal protector		56	Screw	Stainless steel
28	O-ring	NBR	57	Float switch	
29	Stator				

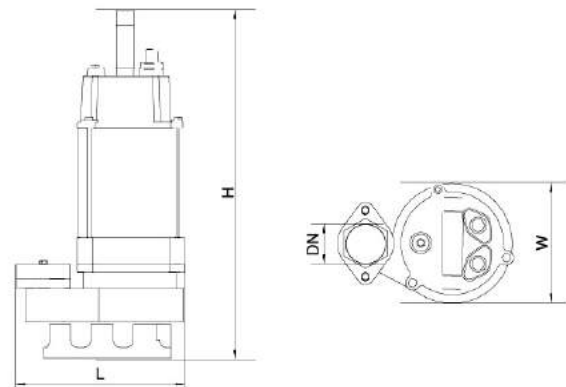
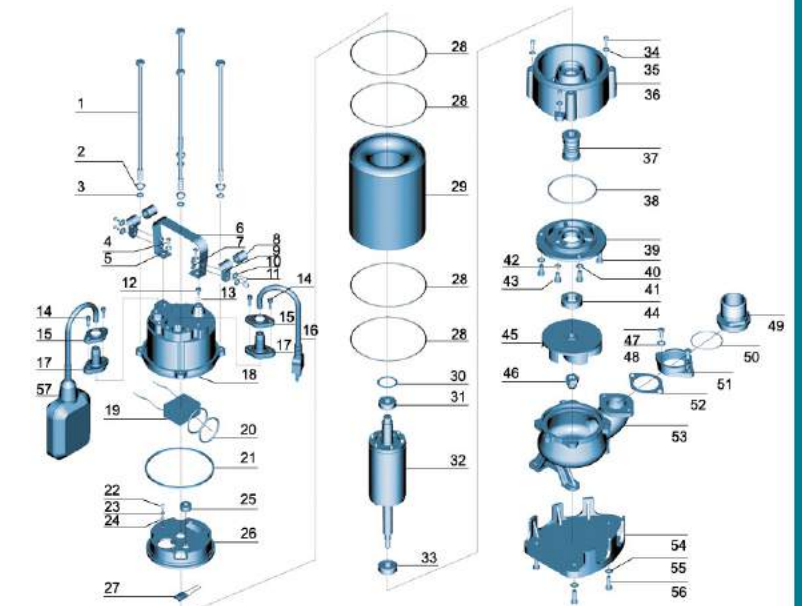

### Dimension

Model	DN	L (mm)	W (mm)	H (mm)
XSP12-8.5/0.45I	2"	225	150	450
XSP18-12/0.75I	2"	226	159	500





### Application

- Wastewater drainage in factories, construction sites and commercial facilities
- Drainage system in municipal sewage treatment plants
- Drainage station in residential quarters
- Municipal projects
- Methane pools and field irrigation in countryside

### Pump

- Max. immersion depth: 5 m
- Max. liquid temperature: +40°C
- Liquid pH value: 4 – 10
- Liquid kinematic viscosity:  $7 \times 10^{-7} \sim 23 \times 10^{-6} \text{ m}^2/\text{s}$
- Max. liquid density:  $1.2 \times 10^3 \text{ kg/m}^3$

### Motor

- Copper winding
- Built-in thermal protector
- Stainless steel welded shaft
- Insulation class: B
- Protection class: IP68

### Identification Codes

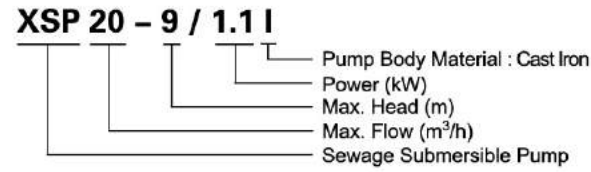

### Hydraulic Performance Curves

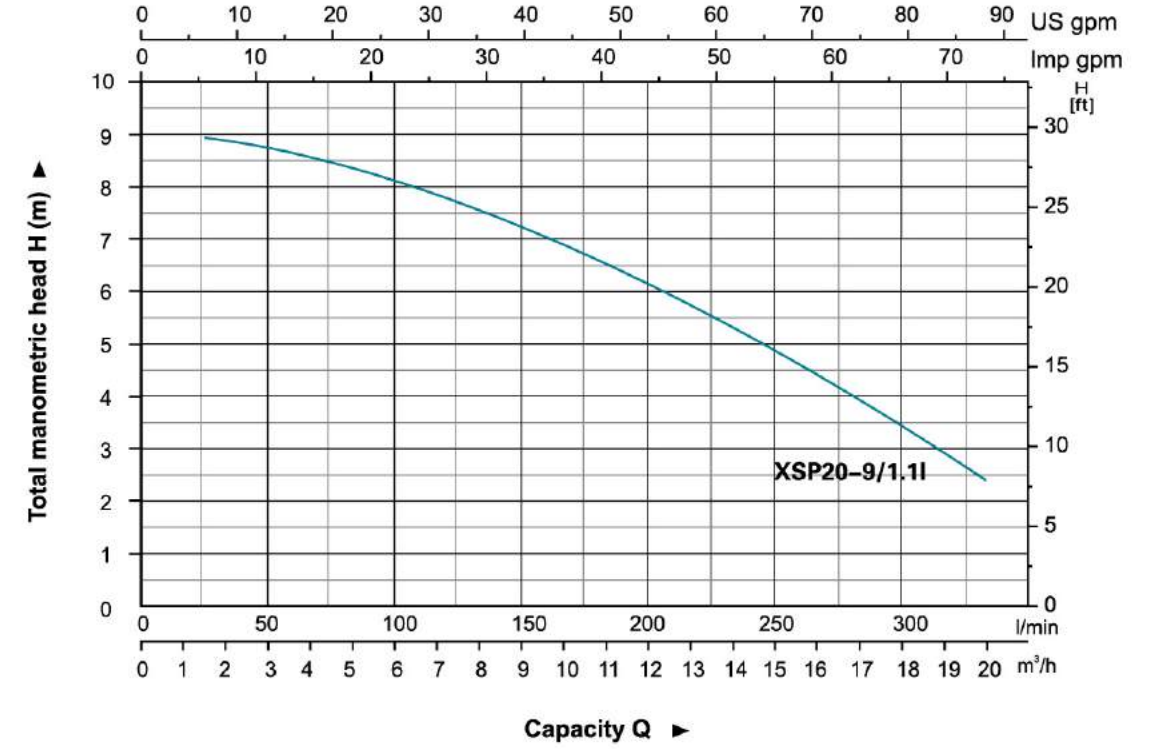

### Technical Data

Model	Power		Outlet diameter (mm)	Voltage (V/Hz)	Max. flow (l/min)	Max. head (m)	Max. dia. of particle (mm)	GW (kgs)	Packing size (mm)	Quantity (PCS/20' TEU)
	(kW)	HP								
XSP20-9/1.1I	1.1	1.5	50	220/50	333	9	35	20.9	580x320x250	681

### Materials Table

No.	Part	Material	No.	Part	Material
1	Bolt	Stainless steel	24	Washer	CuZn40
2	Stretching washer	Stainless steel	25	Cable holder	NBR
3	Washer	Stainless steel	26	Upper cover	HT200
4	Bolt	Stainless steel	27	Thermal protector	
5	Washer	Stainless steel	28	O-ring	NBR
6	Handle	Stainless steel	29	Stator	
7	Nut	Stainless steel	30	Wave washer	65Mn
8	Protector	NR	31	Ball bearing	
9	Cable presser	Stainless steel	32	Rotor	
10	Washer	Stainless steel	33	Ball bearing	
11	Screw	Stainless steel	34	Lower cover	HT200
12	Bolt	Stainless steel	35	Mechanical seal	Ceramic/Carbon
13	O-ring	NBR	36	Connector	ABS
14	Screw	Stainless steel	37	O-ring	NBR
15	Flange	Stainless steel	38	Pump body	HT200
16	Cable		39	Oil seal	
17	Cable protector	CR	40	Impeller	HT200
18	Capacitor cover	HT200	41	Nut	Stainless steel
19	Capacitor		42	Pump cover	Stainless steel
20	O-ring	NBR	43	Base plate	Stainless steel
21	Rubber washer	NBR	44	Washer	Stainless steel
22	Screw	CuZn40	45	Bolt	Stainless steel
23	Stretching washer	65Mn	46	Float switch	

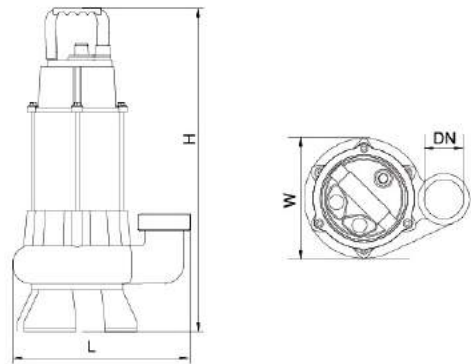
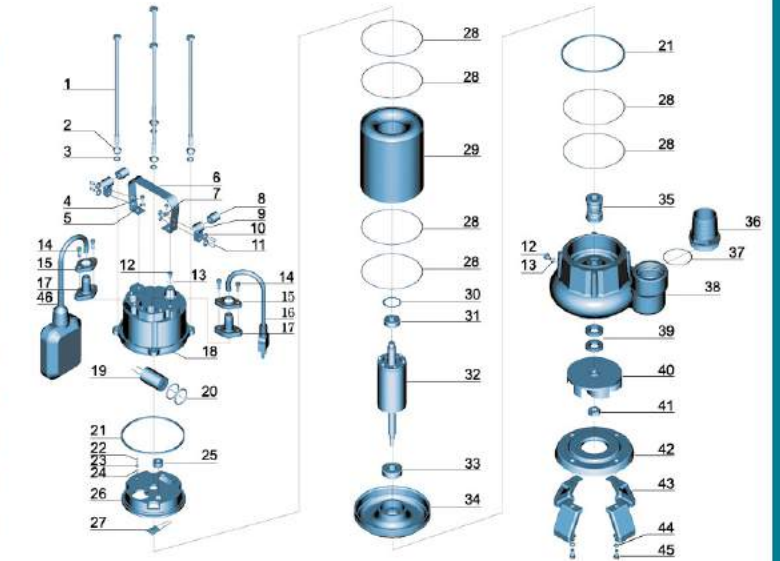

### Dimension

Model	DN	L (mm)	W (mm)	H (mm)
XSP20-9/1.1I	2"	280	200	530





### Application

- Wastewater drainage in factories, construction sites and commercial facilities
- Drainage system in municipal sewage treatment plants
- Drainage station in residential quarters
- Municipal projects
- Methane pools and field irrigation in countryside

### Pump

- Max. immersion depth: 5 m
- Max. liquid temperature: +40°C
- Liquid pH value: 4 – 10
- Liquid kinematic viscosity:  $7 \times 10^{-7} \sim 23 \times 10^{-6} \text{ m}^2/\text{s}$
- Max. liquid density:  $1.2 \times 10^3 \text{ kg/m}^3$

### Motor

- Copper winding
- Built-in thermal protector
- Stainless steel welded shaft
- Insulation class: B
- Protection class: IP68

### Identification Codes

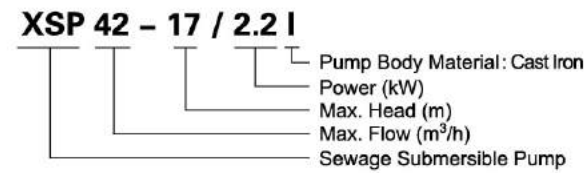

### Hydraulic Performance Curves

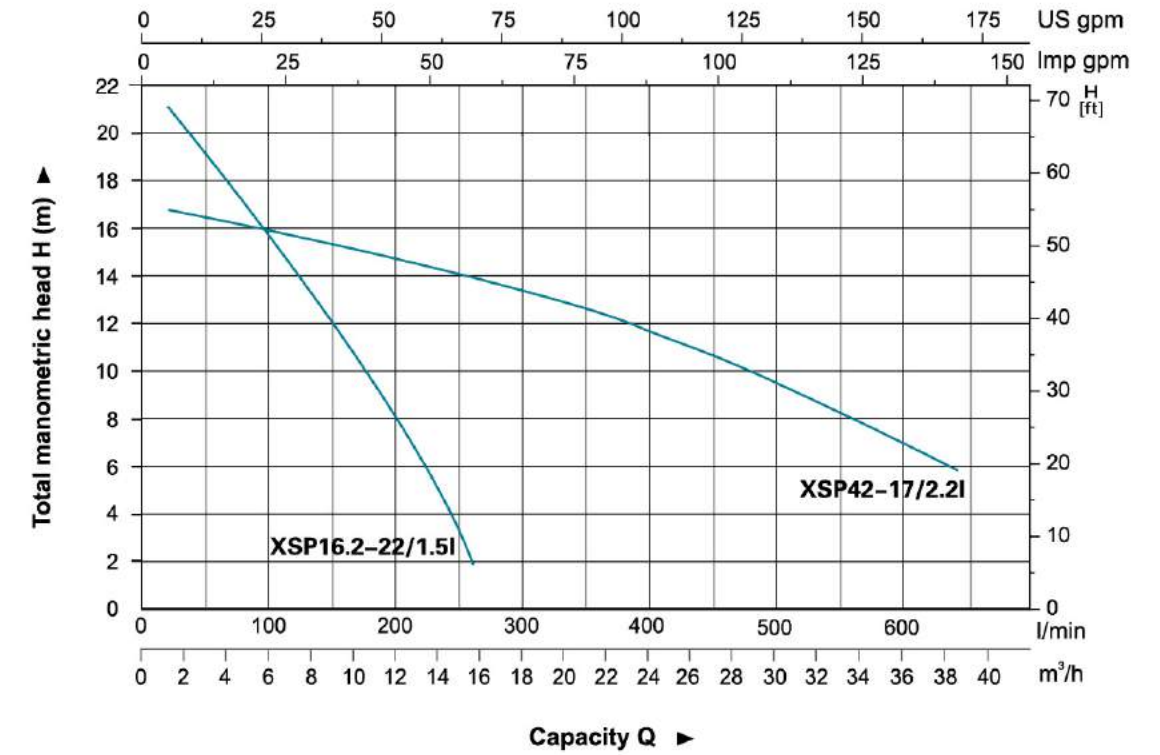

### Technical Data

Model	Power		Outlet diameter (mm)	Voltage (V/Hz)	Max. flow (l/min)	Max. head (m)	Max. dia. of particle (mm)	GW (kgs)	Packing size (mm)	Quantity (PCS/20 TEU)
	(kW)	HP								
XSP16.2-22/1.5I	1.5	2.0	40	220/50	270	22	10	27.6	585x350x245	540
XSP42-17/2.2I	2.2	3.0	75	220/50	700	17	20	29.7	585x350x245	540

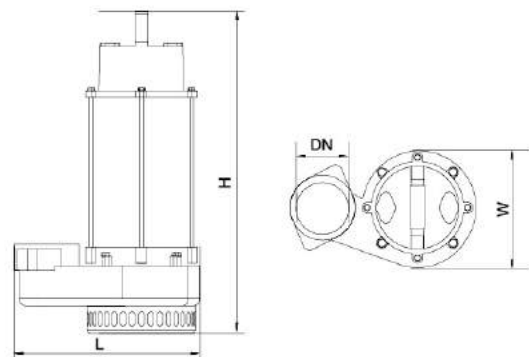

### Dimension

Model	DN	L (mm)	W (mm)	H (mm)
XSP16.2-22/1.5I	1 1/2"	308	198	530
XSP42-17/2.2I	3"	302	190	535

### Materials Table

No.	Part	Material	No.	Part	Material
1	Bolt	Stainless steel	31	Ball bearing	
2	Stretching washer	Stainless steel	32	Rotor	
3	Washer	Stainless steel	33	Ball bearing	
4	Bolt	Stainless steel	34	Screw	Stainless steel
5	Washer	Stainless steel	35	Washer	Stainless steel
6	Handle	Stainless steel	36	Connection part	HT 200
7	Nut	Stainless steel	37	Mechanical seal	Ceramic/Carbon
8	Protector	NR	38	O-ring	NBR
9	Cable presser	Stainless steel	39	Oil chamber cover	HT 200
10	Washer	Stainless steel	40	Screw	Stainless steel
11	Screw	Stainless steel	41	Washer	Stainless steel
12	Bolt	Stainless steel	42	O-ring	NBR
13	O-ring	NBR	43	Screw	Stainless steel
14	Screw	Stainless steel	44	Oil seal	
15	Flange	Stainless steel	45	Impeller	HT 200
16	Cable		46	Nut	Stainless steel
17	Cable protector	CR	47	Bolt	Stainless steel
18	Capacitor cover	HT 200	48	Washer	Stainless steel
19	Capacitor		49	Out-let connector	ABS
20	O-ring	NBR	50	O-ring	NBR
21	Rubber washer	NBR	51	Connection nut	HT 200
22	Screw	CuZn40	52	Rubber washer	NBR
23	Stretching washer	65Mn	53	Pump body	HT 200
24	Washer	CuZn40	54	Base plate	HT 200
25	Line protector	NBR	55	Washer	Stainless steel
26	Motor cover	HT 200	56	Screw	Stainless steel
27	Thermal protector		57	Key	
28	O-ring	NBR	58	Float switch	
29	Motor stator	Stainless steel			
30	Undulated washer	65Mn			

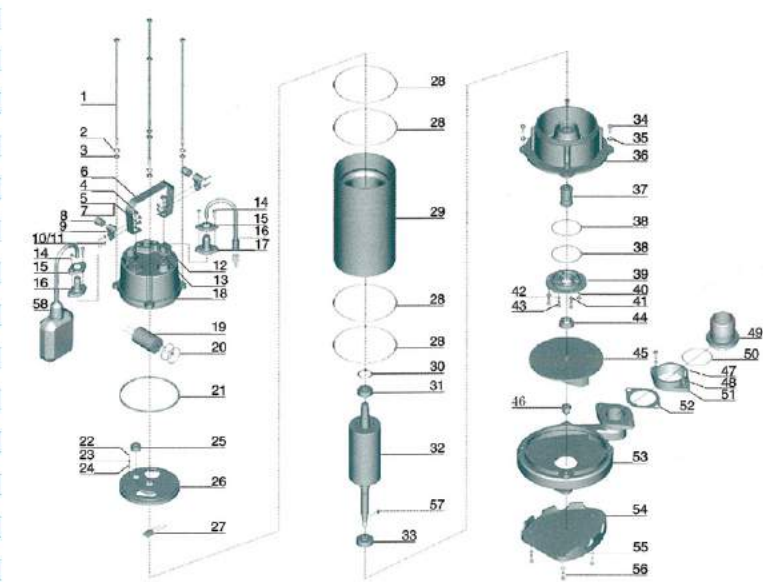





### Application

- Wastewater drainage in factories, construction sites and commercial facilities
- Drainage system in municipal sewage treatment plants
- Drainage station in residential quarters
- Municipal projects
- Methane pools and field irrigation in countryside

### Pump

- Max. immersion depth: 5 m
- Max. liquid temperature: +40°C
- Liquid pH value: 4 – 10
- Liquid kinematic viscosity:  $7 \times 10^{-7} \sim 23 \times 10^{-6} \text{ m}^2/\text{s}$
- Max. liquid density:  $1.2 \times 10^3 \text{ kg/m}^3$

### Motor

- Copper winding
- Built-in thermal protector
- Stainless steel welded shaft
- Insulation class: B
- Protection class: IP68

### Identification Codes

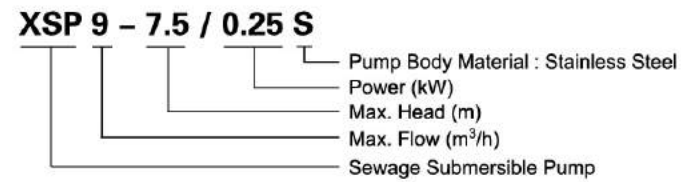

### Hydraulic Performance Curves

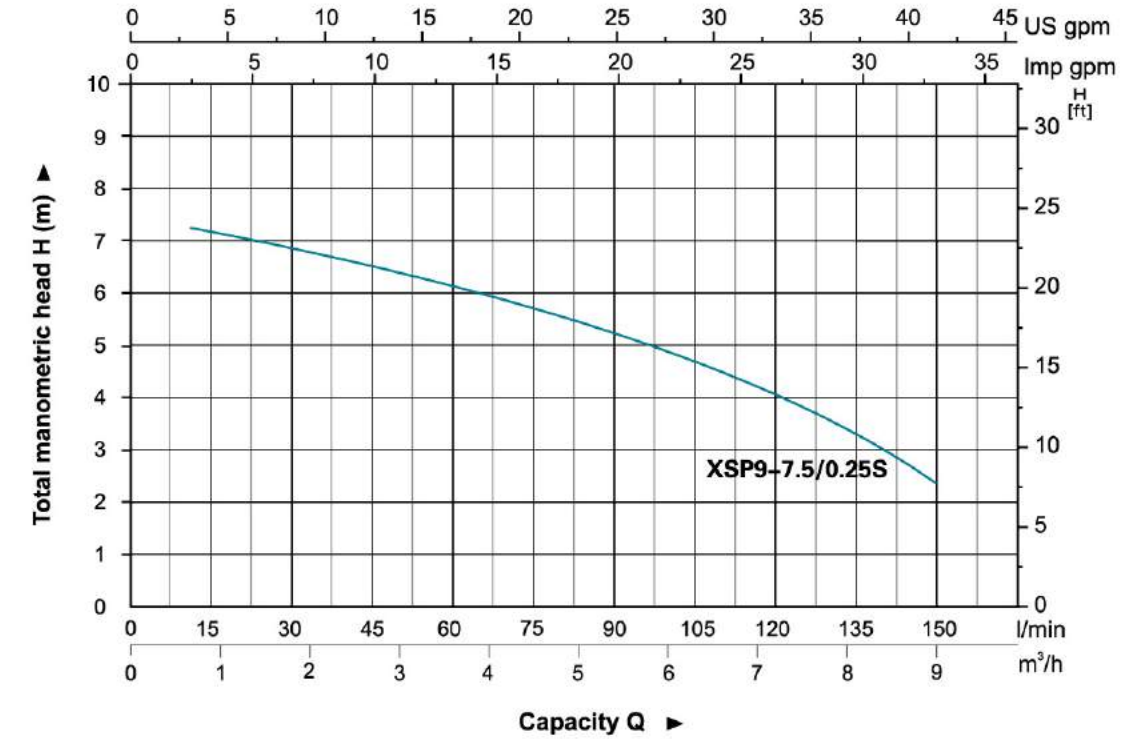

### Technical Data

Model	Power		Outlet diameter (mm)	Voltage (V/Hz)	Max. flow (l/min)	Max. head (m)	Max. dia. of particle (mm)	GW (kgs)	Packing size (mm)	Quantity (PCS/20' TEU)
	(kW)	HP								
XSP9-7.5/0.25S	0.25	0.33	40,32,25	220/50	150	7.5	15	10.5	185x180x380	2110

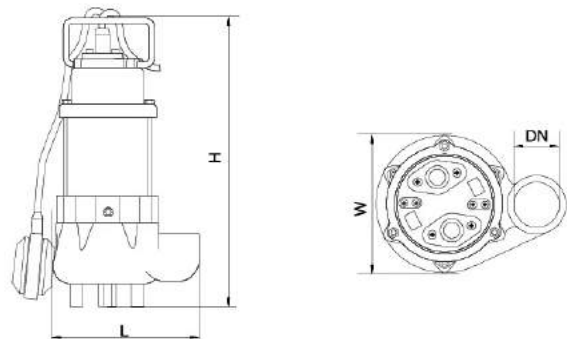

### Dimension

Model	DN	L (mm)	W (mm)	H (mm)
XSP9-7.5/0.25S	1 1/4"	165	120	360

### Materials Table

No.	Part	Material	No.	Part	Material
1	Bolt	Stainless steel	25	Stator	Stainless steel
2	Stretching washer	Stainless steel	26	Screw	Stainless steel
3	Washer	Stainless steel	27	Stretching washer	Stainless steel
4	Handle	Stainless steel	28	Thermal protector	65Mn
5	Screw	Stainless steel	29	Wave washer	65Mn
6	Cable		30	Ball bearing	
7	Flange	Stainless steel	31	Rotor	
8	Cable protector	CR	32	Ball bearing	
9	Capacitor cover	Stainless steel	33	Rubber washer	FKM
10	Screw	Stainless steel	34	Screw	Stainless steel
11	Cable presser	Stainless steel	35	O-ring	FKM
12	Protector	FKM	36	Connection part	Stainless steel
13	O-ring	NBR	37	Mechanical seal	Ceramic/Carbon
14	Capacitor		38	O-ring	FKM
15	Rubber washer	FKM	39	Oil chamber cover	Stainless steel
16	Screw	Steel	40	Washer	Stainless steel
17	Stretching washer	65Mn	41	Screw	Stainless steel
18	Washer	Steel	42	Oil seal	
19	Press plate	Steel	43	Impeller	Stainless steel
20	Cable holder	NBR	44	Nut	Stainless steel
21	Screw	CuZn40	45	Connector	ABS
22	Stretching washer	65Mn	46	O-ring	FKM
23	Washer	CuZn40	47	Pump body	Stainless steel
24	Nut	Stainless steel			

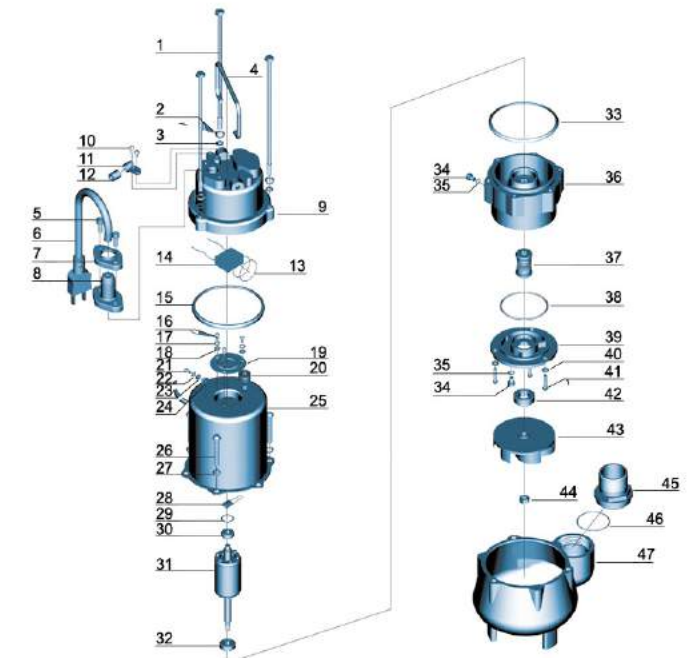



### Application

- Wastewater drainage in factories, construction sites and commercial facilities
- Drainage system in municipal sewage treatment plants
- Drainage station in residential quarters
- Municipal projects
- Methane pools and field irrigation in countryside

### Pump

- Max. immersion depth: 5 m
- Max. liquid temperature: +40°C
- Liquid pH value: 4 – 10
- Liquid kinematic viscosity:  $7 \times 10^{-7} \sim 23 \times 10^{-6} \text{ m}^2/\text{s}$
- Max. liquid density:  $1.2 \times 10^3 \text{ kg/m}^3$

### Motor

- Copper winding
- Built-in thermal protector
- Stainless steel welded shaft
- Insulation class: B
- Protection class: IP68

### Identification Codes

**XSP 18 - 12 / 0.75 S**

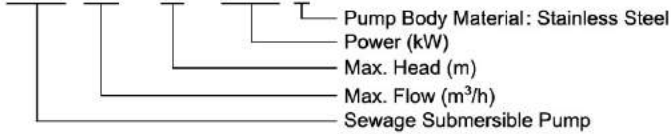

### Hydraulic Performance Curves

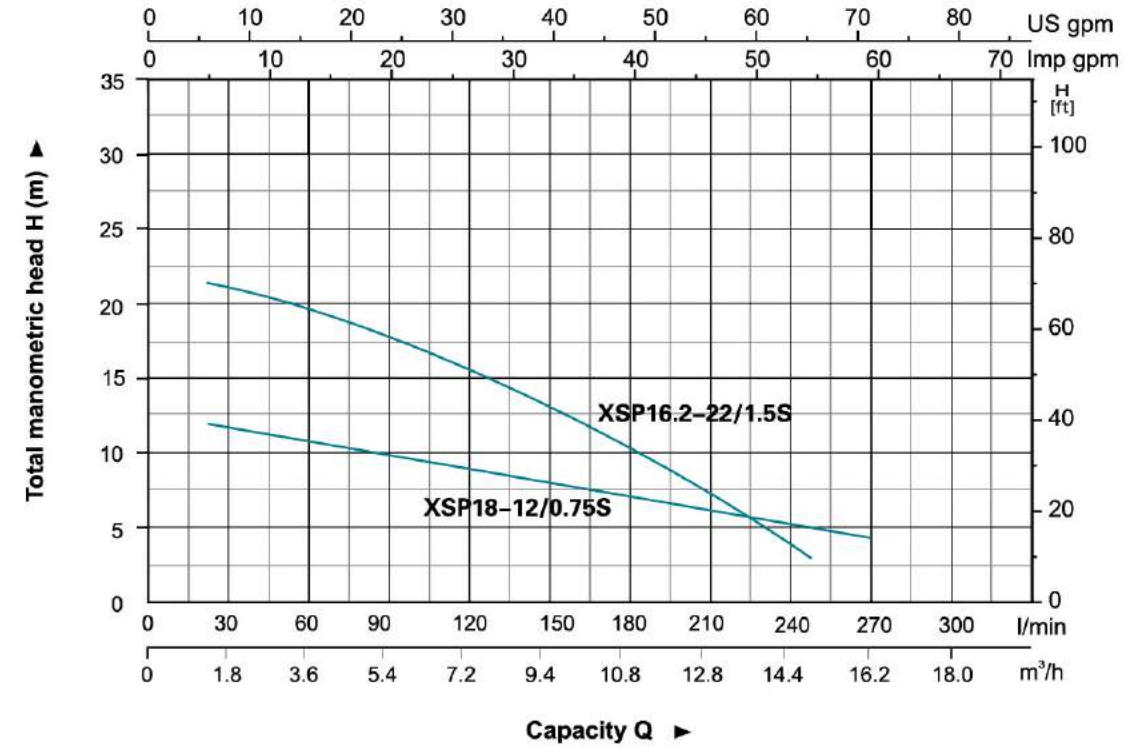

### Technical Data

Model	Power		Outlet diameter (mm)	Voltage (V/Hz)	Max. flow (l/min)	Max. head (m)	Max. dia. of particle (mm)	GW (kgs)	Packing size (mm)	Quantity (PCS/20 TEU)
	(kW)	HP								
XSP18-12/0.75S	0.75	1.0	50	220/50	300	12	25	22.2	540x265x195	1056
XSP16.2-22/1.5S	1.5	2.0	40	220/50	270	22	10	27.5	585x350x245	540

### Materials Table

No.	Part	Material	No.	Part	Material
1	Bolt	Stainless steel	29	Stator	
2	Stretching washer	Stainless steel	30	Wave washer	65Mn
3	Washer	Stainless steel	31	Ball bearing	
4	Bolt	Stainless steel	32	Rotor	
5	Washer	Stainless steel	33	Ball bearing	
6	Handle	Stainless steel	34	Screw	Stainless steel
7	Nut	Stainless steel	35	Washer	Stainless steel
8	Protector	FKM	36	Connection part	Stainless steel
9	Cable presser	Stainless steel	37	Mechanical seal	Ceramic/Carbon
10	Washer	Stainless steel	38	O-ring	FKM
11	Screw	Stainless steel	39	Oil chamber cover	Stainless steel
12	Bolt	Stainless steel	40	Screw	Stainless steel
13	O-ring	FKM	41	Washer	Stainless steel
14	Bolt	Stainless steel	42	O-ring	FKM
15	Flange	Stainless steel	43	Screw	Stainless steel
16	Cable		44	Oil seal	
17	Cable protector	CR	45	Impeller	Stainless steel
18	Capacitor cover	Stainless steel	46	Nut	
19	Capacitor		47	Bolt	Stainless steel
20	O-ring	NBR	48	Washer	Stainless steel
21	Rubber washer	FKM	49	Connector	ABS
22	Screw	CuZn40	50	O-ring	FKM
23	Stretching washer	65Mn	51	Connection nut	Stainless steel
24	Washer	CuZn40	52	Rubber washer	FKM
25	Cable holder	NBR	53	Pump body	Stainless steel
26	Motor cover	HT200	54	Base plate	Stainless steel
27	Thermal protector		55	Washer	Stainless steel
28	O-ring	FKM	56	Screw	Stainless steel

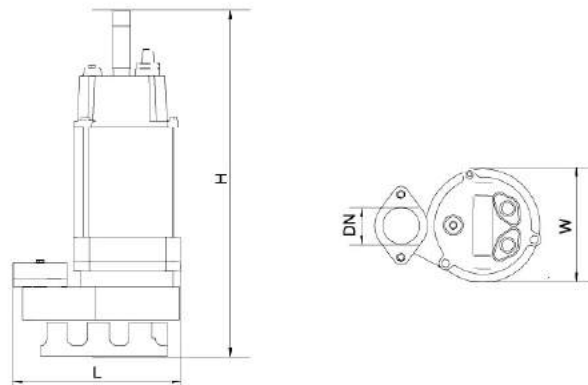
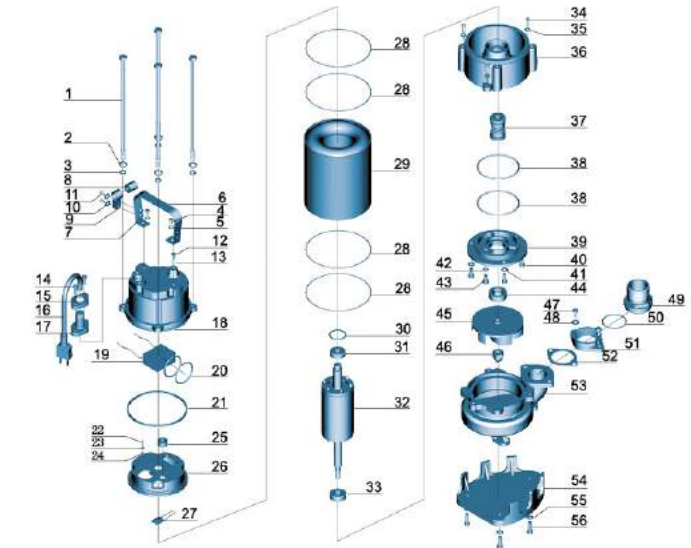

### Dimension

Model	DN	L (mm)	W (mm)	H (mm)
XSP18-12/0.75S	2"	226	159	500
XSP16.2-22/1.5S	2"	275	198	530



### Application

- Wastewater drainage in factories, construction sites and commercial facilities
- Drainage system in municipal sewage treatment plants
- Drainage station in residential quarters
- Municipal projects
- Methane pools and field irrigation in countryside

### Pump

- Max. immersion depth: 5 m
- Max. liquid temperature: +40°C
- Liquid pH value: 4 – 10
- Liquid kinematic viscosity:  $7 \times 10^{-7} \sim 23 \times 10^{-6} \text{ m}^2/\text{s}$
- Max. liquid density:  $1.2 \times 10^3 \text{ kg/m}^3$

### Motor

- Copper winding
- Built-in thermal protector
- Stainless steel welded shaft
- Insulation class: B
- Protection class: IP68

### Identification Codes

**XSP 14 - 7 / 1.1 ID**

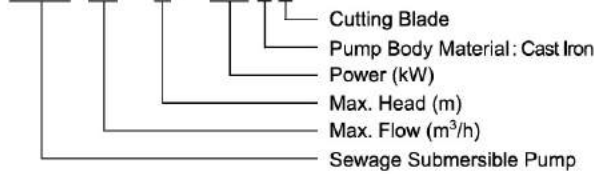

Cutting Blade

### Hydraulic Performance Curves

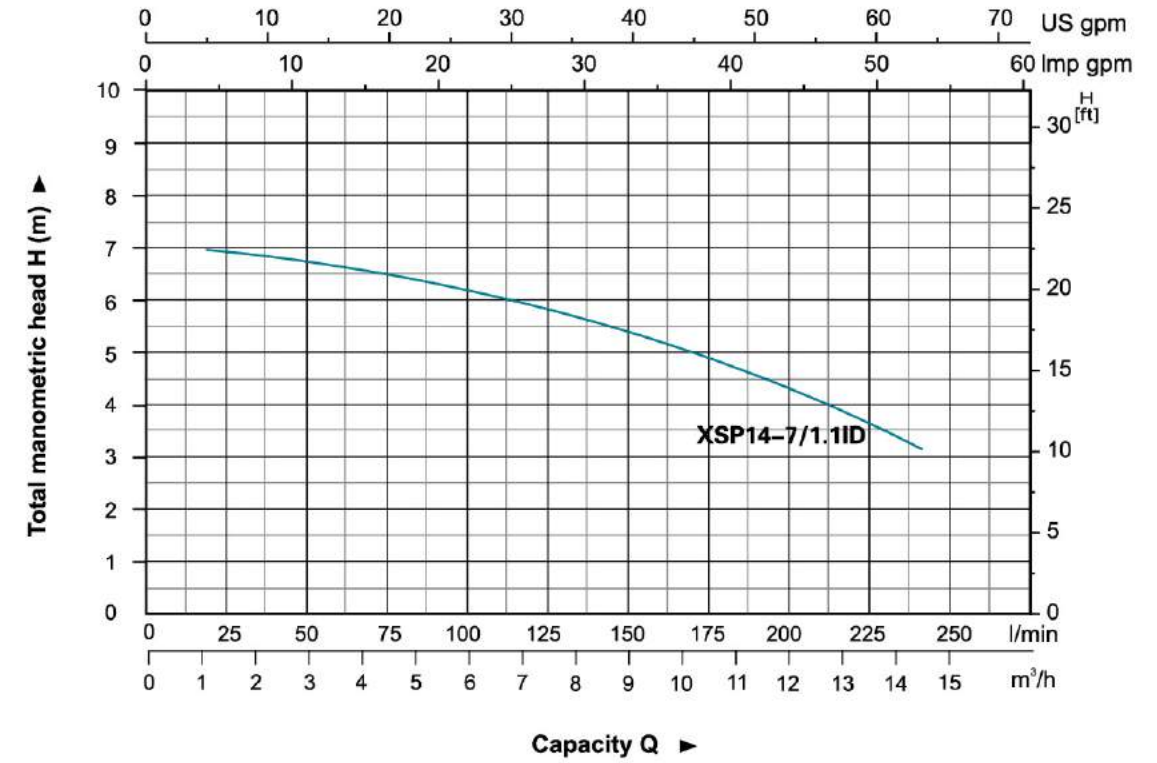

### Technical Data

Model	Power		Outlet diameter (mm)	Voltage (V/Hz)	Max.flow (l/min)	Max.head (m)	Max.dia. of particle (mm)	GW (kgs)	Packing size (mm)	Quantity (PCS/20 TEU)
	(kW)	HP								
XSP14-7/1.1ID	1.1	1.5	50	220/50	233	7	22.5	24	530x295x245	765

### Materials Table

No.	Part	Material	No.	Part	Material
1	Bolt	Stainless steel	26	Upper cover	HT200
2	Stretching washer	Stainless steel	27	Thermal protector	
3	Washer	Stainless steel	28	O-ring	NBR
4	Bolt	Stainless steel	29	Stator	
5	Washer	Stainless steel	30	Wave washer	65Mn
6	Handle	Stainless steel	31	Ball bearing	
7	Nut	Stainless steel	32	Rotor	
8	Protector	NR	33	Key	Steel
9	Cable presser	Stainless steel	34	Ball bearing	
10	Washer	Stainless steel	35	Lower cover	HT200
11	Screw	Stainless steel	36	Mechanical seal	Ceramic/Carbon
12	Bolt	Stainless steel	37	Pump body	HT200
13	O-ring	NBR	38	Oil seal	
14	Screw	Stainless steel	39	Impeller	HT200
15	Flange	Stainless steel	40	Shredding ring	40Cr
16	Cable		41	Washer	Stainless steel
17	Cable protector	CR	42	Screw	Stainless steel
18	Capacitor cover	HT200	43	Radial cutter	40Cr
19	Capacitor		44	Washer	40Cr
20	O-ring	NBR	45	Screw	Stainless steel
21	Rubber washer	NBR	46	Float switch	
22	Screw	CuZn40	47	O-ring	NBR
23	Stretching washer	65Mn	48	Connection nut	ABS
24	Washer	CuZn40	49	Connector	ABS
25	Cable holder	NBR			

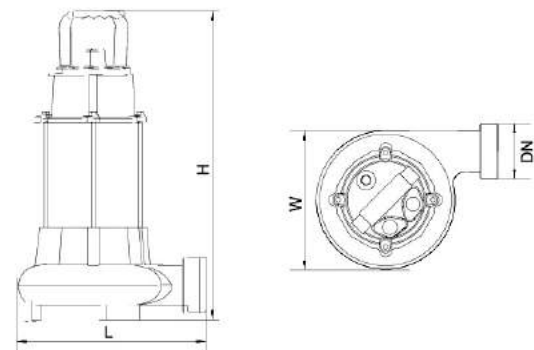
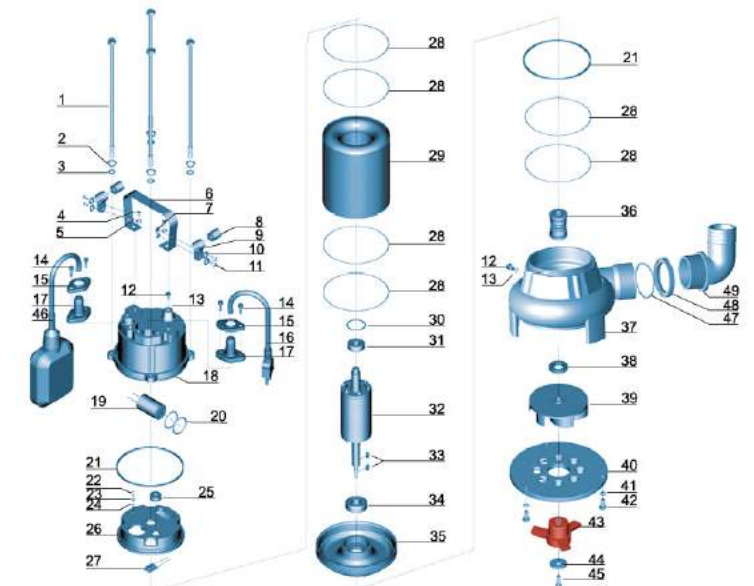

### Dimension

Model	DN	L (mm)	W (mm)	H (mm)
XSP14-7/1.1ID	2"	255	202	478





### Application

- Wastewater drainage in factories, construction sites and commercial facilities
- Drainage system in municipal sewage treatment plants
- Drainage station in residential quarters
- Municipal projects
- Methane pools and field irrigation in countryside

### Pump

- Max. immersion depth: 5 m
- Max. liquid temperature: +40°C
- Liquid pH value: 4 – 10
- Liquid kinematic viscosity:  $7 \times 10^{-7} \sim 23 \times 10^{-6} \text{ m}^2/\text{s}$
- Max. liquid density:  $1.2 \times 10^3 \text{ kg/m}^3$

### Motor

- Copper winding
- Built-in thermal protector
- Stainless steel welded shaft
- Insulation class: B
- Protection class: IP68

### Identificati

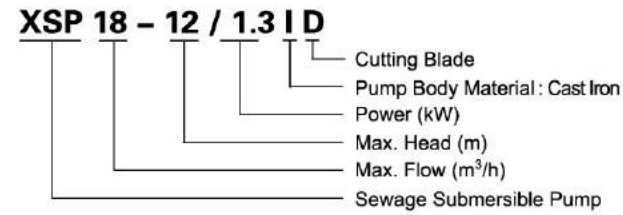

### Technical Data

Model	Power		Outlet diameter (mm)	Voltage (V/Hz)	Max. flow (l/min)	Max. head (m)	GW (kgs)	Packing size (mm)	Quantity (PCS/20 TEU)
	(kW)	HP							
XSP18-12/1.3ID	1.3	1.75	50	220/50	300	12	22.8	570x310x245	675
XSP26.4-10/1.8ID	1.8	2.4	75	220/50	440	10	30	585x350x245	540

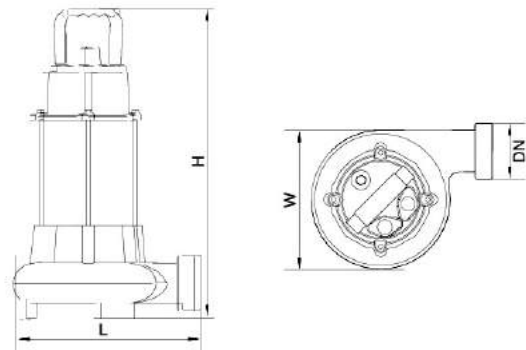

### Dimension

Model	DN	L (mm)	W (mm)	H (mm)
XSP18-12/1.3ID	2"	252	191	510
XSP26.4-10/1.8ID	2 1/2"	290	196	520

### Hydraulic Performance Curves

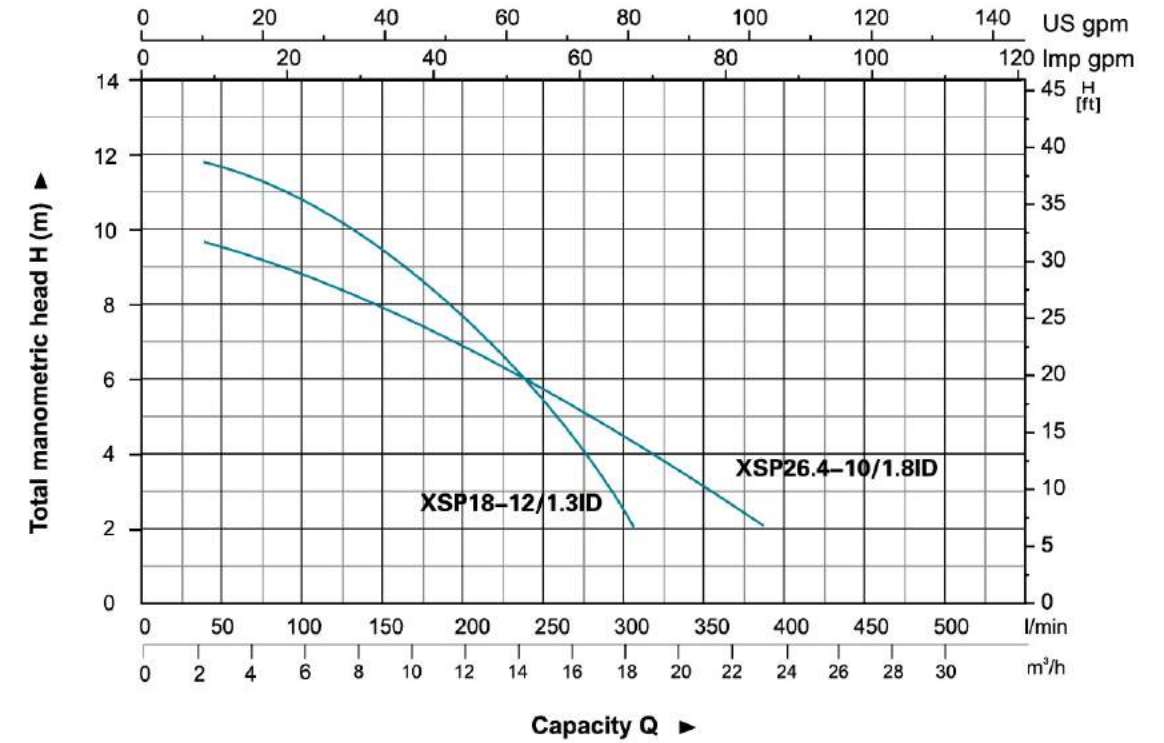

### Materials Table

No.	Part	Material	No.	Part	Material
1	Bolt	Stainless steel	30	Undulsted washer	65Mn
2	Stretching washer	Stainless steel	31	Ball bearing	
3	Washer	Stainless steel	32	Rotor	
4	Bolt	Stainless steel	33	Ball bearing	
5	Washer	Stainless steel	34	Screw	Stainless steel
6	Handle	Stainless steel	35	Washer	Stainless steel
7	Nut	Stainless steel	36	Connection part	HT200
8	Protector	NR	37	Mechanical seal	Ceramic/Carbon
9	Cable presser	Stainless steel	38	O-ring	NBR
10	Washer	Stainless steel	39	Oil chamber cover	HT200
11	Screw	Stainless steel	40	Screw	Stainless steel
12	Bolt	Stainless steel	41	Washer	Stainless steel
13	O-ring	NBR	42	O-ring	NBR
14	Screw	Stainless steel	43	Screw	Stainless steel
15	Flange	Stainless steel	44	Oil seal	
16	Cable		45	Pump body	HT200
17	Cable Protector	CR	46	Impeller	HT200
18	Capacitor cover	HT200	47	Shredding ring	40Cr
19	Capacitor		48	Washer	Stainless steel
20	O-ring	NBR	49	Bolt	Stainless steel
21	Rubber washer	NBR	50	Radial cutter	40Cr
22	Screw	CuZn40	51	Washer	40Cr
23	Stretching washer	65Mn	52	Screw	Stainless steel
24	Washer	CuZn40	53	Key	Steel
25	Line protector	NBR	54	Float switch	
26	Motor cover	HT200	55	O-ring	NBR
27	Thermal protector		56	Connection nut	ABS
28	O-ring	NBR	57	Out-let connector	ABS
29	Motor stator	Stainless steel			

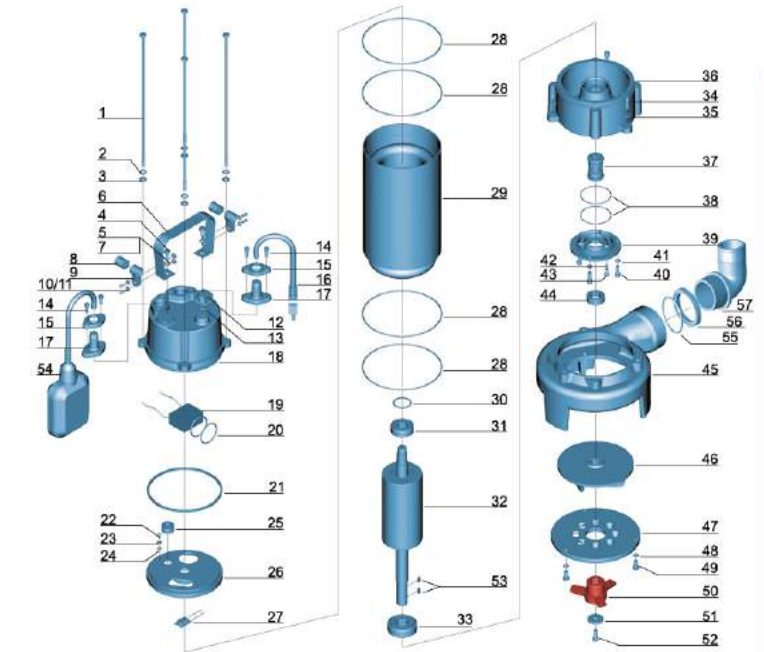





### Product Feature

- The pump body is located in the bottom of the pump. The pump suction is equal to the length of the pipe, can replace other surface pumps and solve the problem of failing to pump water up due to the decline of water level.
- Max diameter of pump is 42mm. The water pump can be used in well whose diameter is more than 50mm
- This pump is provided with excellent anti freezing function; when the pump is powered off, there is no water inside the pump body and the pipe, so pump body or pipe shall be free of any crack when used in cold winter.

### Application

- Flexible shaft pump is suitable for household water, Cultivation, such as irrigation occasion which water consumption is not big
- Apply to water solid content (Quality estimation)  $\leq 1\%$
- Water PH 6.5~8.5
- Chlorine ion content in water  $\leq 400\text{mg/L}$
- Max.ambient Temperature:  $+40^{\circ}\text{C}$

### Configuration

- Copper wire motor with protector
- High quality stator
- IP54

### Identification Codes

**FSP 750 - 25**

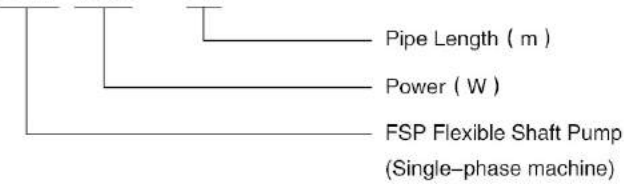

### Technical Data

Model	Power			Q(m <sup>3</sup> /h)	0.3	0.7	0.95	1.3	1.5
	kW	HP	Hz						
FSP750-25	0.75	1	50/60	H(m)	81.3	50.1	31.2	10	5

(Note: The FSP length does not affect the performance)

### Installation Drawing

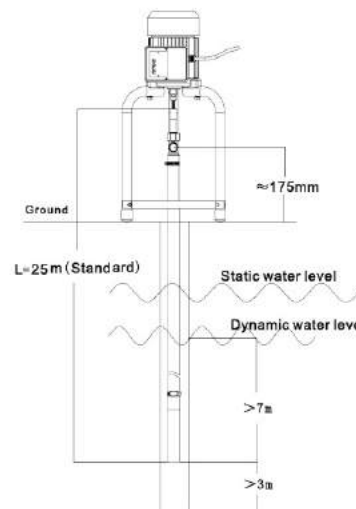
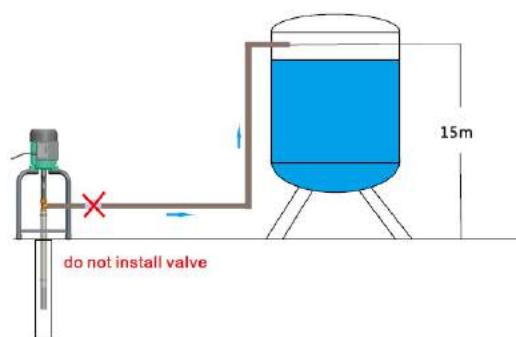

### Mounting Dimension

(Flexible shaft pump length L,  
According to water depth matching, pipe  
standard length 25m)

### Hydraulic Performance Curves

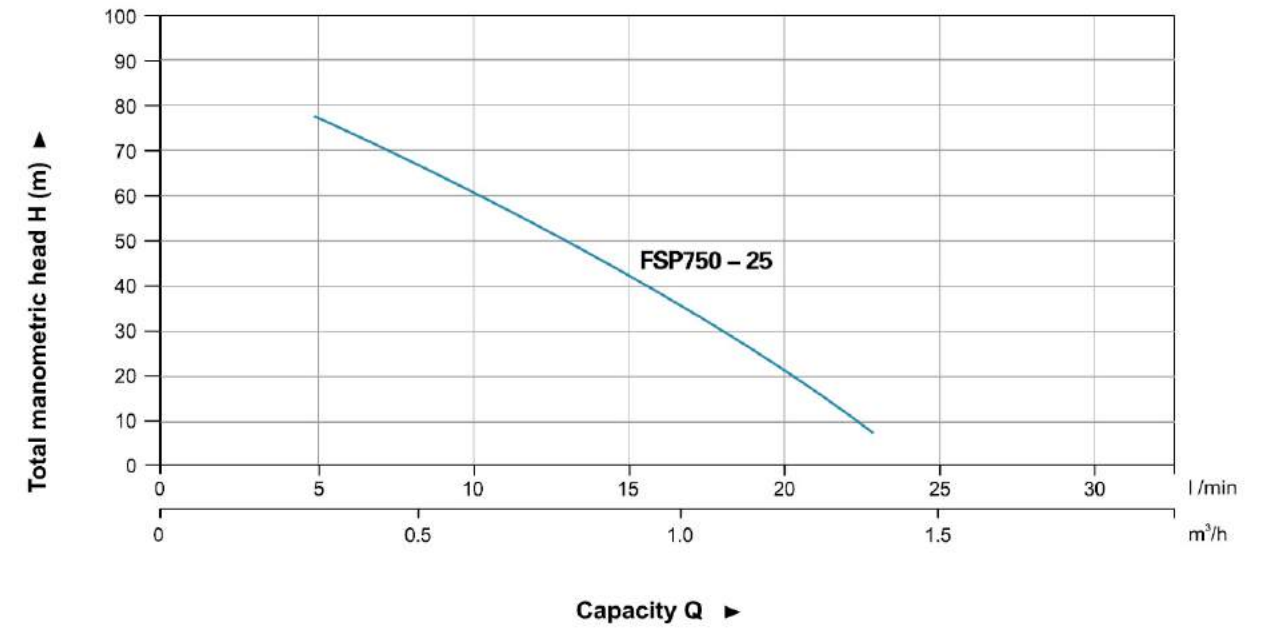

### Materials Table

No.	Part	Material	No.	Part	Material
1	Front end cover	HT200	15	External pipe	PP
2	Oil seal	NBR	16	Hose clamp	304
3	Bearing	GCr15	17	Hose clamp	304
4	Rotor		18	Bearing sheath	Q235
5	Cover box	ABS	19	Component of soft shaft	
6	Capacitor		20	Internal pipe	PP
7	Cover lid	ABS	21	Component of pump head	
8	Stator		22	Support	Q235
9	Outgoing line		23	Rail	Q235
10	Rear end cover	HT200			
11	VD type sealing ring				
12	Fan	PP			
13	Fan cover	Q235			
14	Tee	Brass			

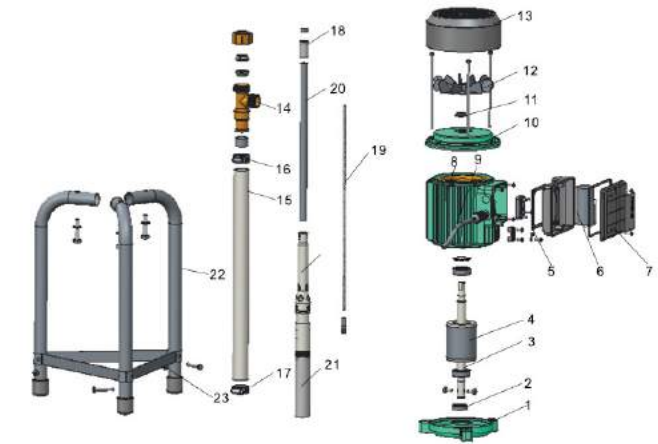

### Package Information

Model	Packaging	NO.	GW (Kg)	H (mm)	W (mm)	L (mm)
FSP750-40	FSP	1	21.5	230	1115	1120
	Motor & Parts	1	8.5	405	200	250
FSP750-35	FSP	1	17.5	115	1115	1120
	Motor & Parts	1	8.5	405	200	250
FSP750-30	FSP	1	14.5	115	1115	1120
	Motor & Parts	1	8.5	405	200	250
FSP750-25	FSP	1	12	115	1115	1120
	Motor & Parts	1	8.5	405	200	250
FSP750-20	FSP	1	10	115	1115	1120
	Motor & Parts	1	8.5	405	200	250
FSP750-15	FSP	1	8.5	115	1115	1120
	Motor & Parts	1	8.5	405	200	250

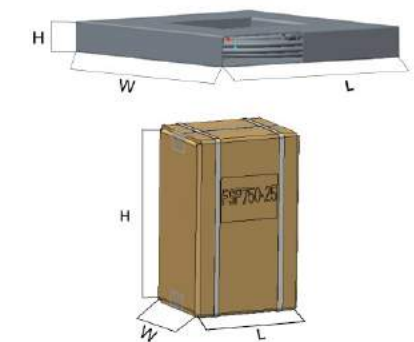





### Application

- The lifting station is suitable for pumping of wastewater off places in private dwellings and basements where wastewater cannot be led directly to the sewer by means of a natural downward slope.
- It is typically used for:
  - Renovation of offices or other commercial buildings
  - Wall-mounted toilets in basements below sewer level
  - Washing machines & dish washers
  - Toilets, wash basins, bathtubs and cabinet showers in the bathrooms where the location may be remote from the main soil pipe so that a natural slope cannot be established

### Features

- Compact and slim for easy installation
- Automatic start and stop
- Top quality air switch and carbon filter from Germany
- Circuit board with time delay function and low voltage protection
- Low noise
- New blade and support with better cutting performance
- Suitable for sewage water containing toilet paper and faeces with cutting blade

### Operating Conditions

- Max. liquid temperature: 50°C
- Max. ambient temperature: 35°C
- PH value: 4 - 10
- The pump must not be used for strong chemicals or solvents

### Identification Codes

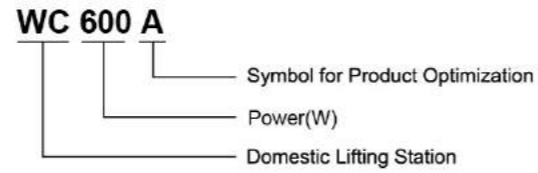

### Technical Data

MODEL	POWER (P1)	Q (m³/h)	0	2.4	3.0	3.6	4.5	4.8	5.1
Single Phase	W	Q (l/min)	0	40	50	60	75	80	85
WC600A	600	H (m)	8.7	7.5	6.5	6	4.5	4	3.3

### Dimension

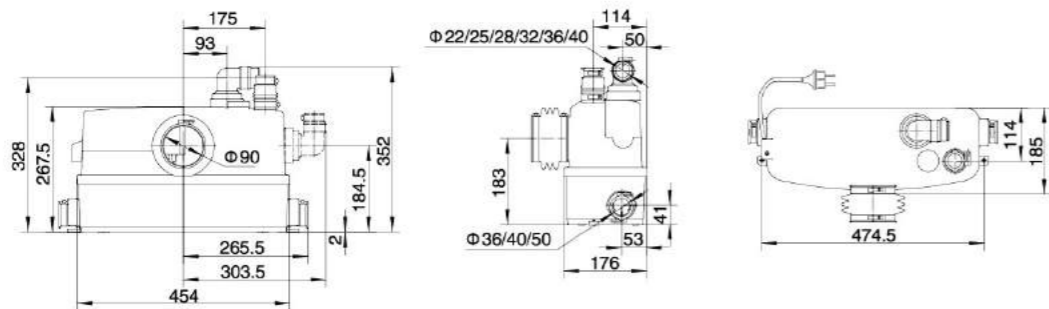

### Hydraulic Performance Curves

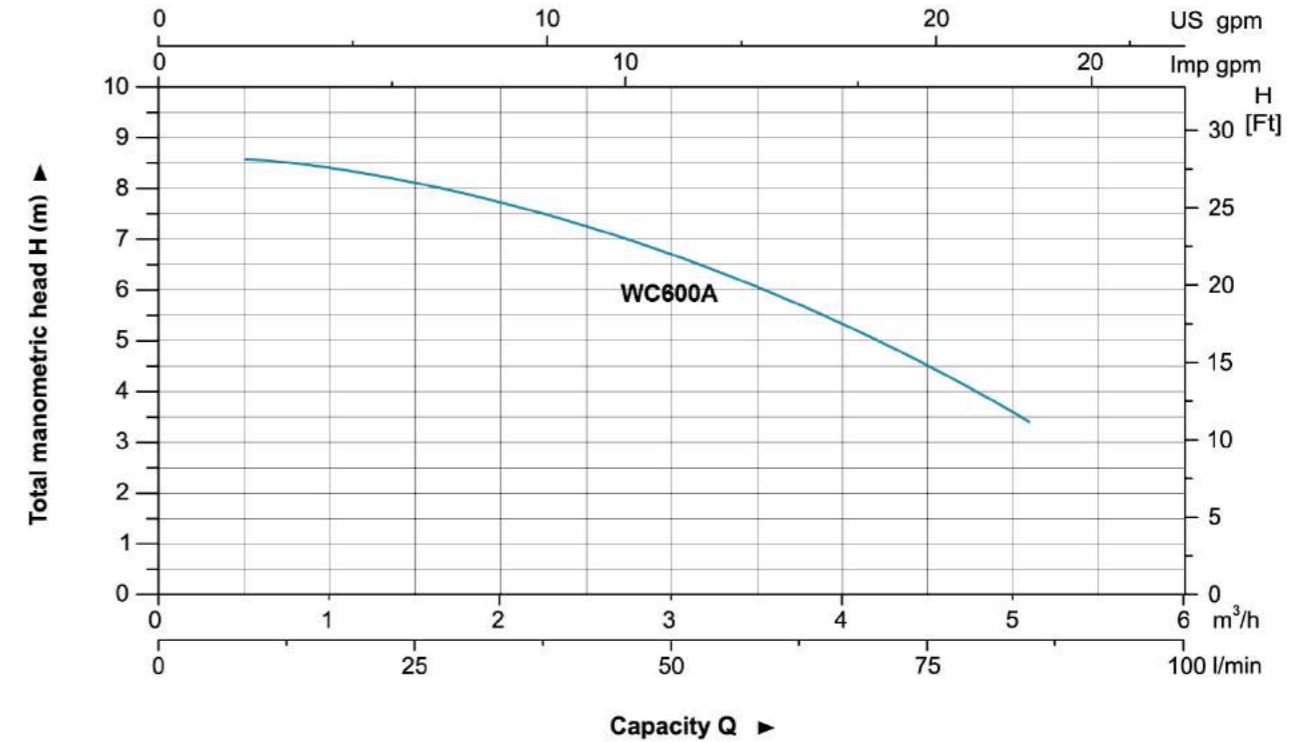

### Materials Table

No.	Part	Material	No.	Part	Material
1	Outlet	EPDM	18	Impeller	PPO
2	Connector	PP	19	Cutting blade	AISI 304
3	3-Way	PP	20	Stirrer	PPO
4	Cover	PP	21	Water tank	ABS
5	Outlet cover	ABS	22	Outlet	NBR
6	Motor cover	ABS	23	Feed pipe	EPDM
7	Air switch				
8	Capacitor				
9	Tank cover	ABS			
10	Pump body	PP			
11	Cutting ring	AISI 304			
12	Circuit board				
13	Upper cover	ZL 102			
14	Rotor				
15	Stator				
16	Bearing seat	ZL102			
17	Stator shield	ZG 304			

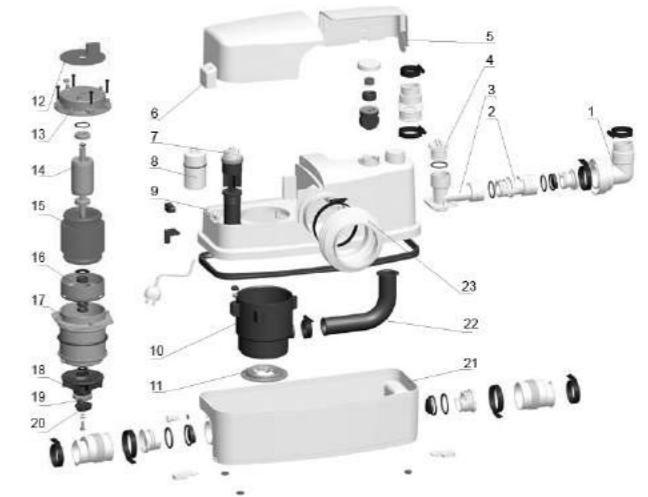

### Package Information

Model	GW (Kgs)	L (mm)	W (mm)	H (mm)	Quantity (PCS/20 TEU)
WC600A	9.6	495	215	370	720







### Application

- It is used for water circulation in all kinds of small domestic swimming pools. Slightly dirty water with solids in suspension can be perfectly filtered.

### Pump

- Engineering plastic pump body
- Max. liquid temperature: +35°C

### Motor

- Motor with copper or aluminum winding
- Built-in thermal protector for single phase motor
- Insulation class: F
- Protection class: IPX5

### Identification Codes

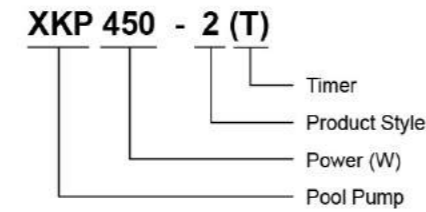

### Technical Data

MODEL	POWER (P <sub>1</sub> ) W	Q (m <sup>3</sup> /h) Q (l/min)	H (m)									
			1	2	3	4	5	6	7	8	9	10
XKP250-2(T)	250	17	6.9	6.3	5.5	4.6	3.6	2.4	1.0	-	-	-
XKP300-2(T)	300	20	7.7	7.2	6.4	5.5	4.5	3.0	1.0	-	-	-
XKP350-2(T)	350	23	8.4	7.7	7.0	6.2	5.0	3.8	2.3	0.8	-	-
XKP450-2(T)	450	26	9.6	9.1	8.5	8.0	7.3	6.4	5.2	4.0	2.4	-

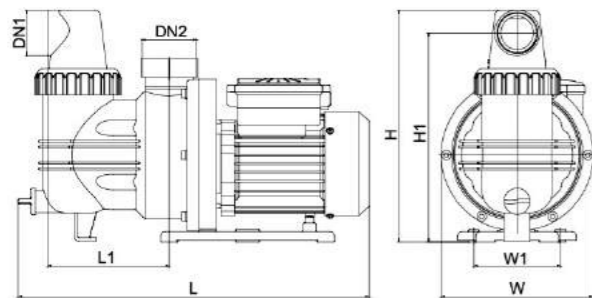

### Dimension

Model	DN1	DN2	L (mm)	W (mm)	H (mm)	L1 (mm)	W1 (mm)	H1 (mm)
XKP250-2(T)	40	40	416	175	265	140	100	239
XKP300-2(T)	40	40	416	175	265	140	100	239
XKP350-2(T)	40	40	416	175	265	140	100	239
XKP450-2(T)	40	40	416	175	265	140	100	239

### Hydraulic Performance Curves

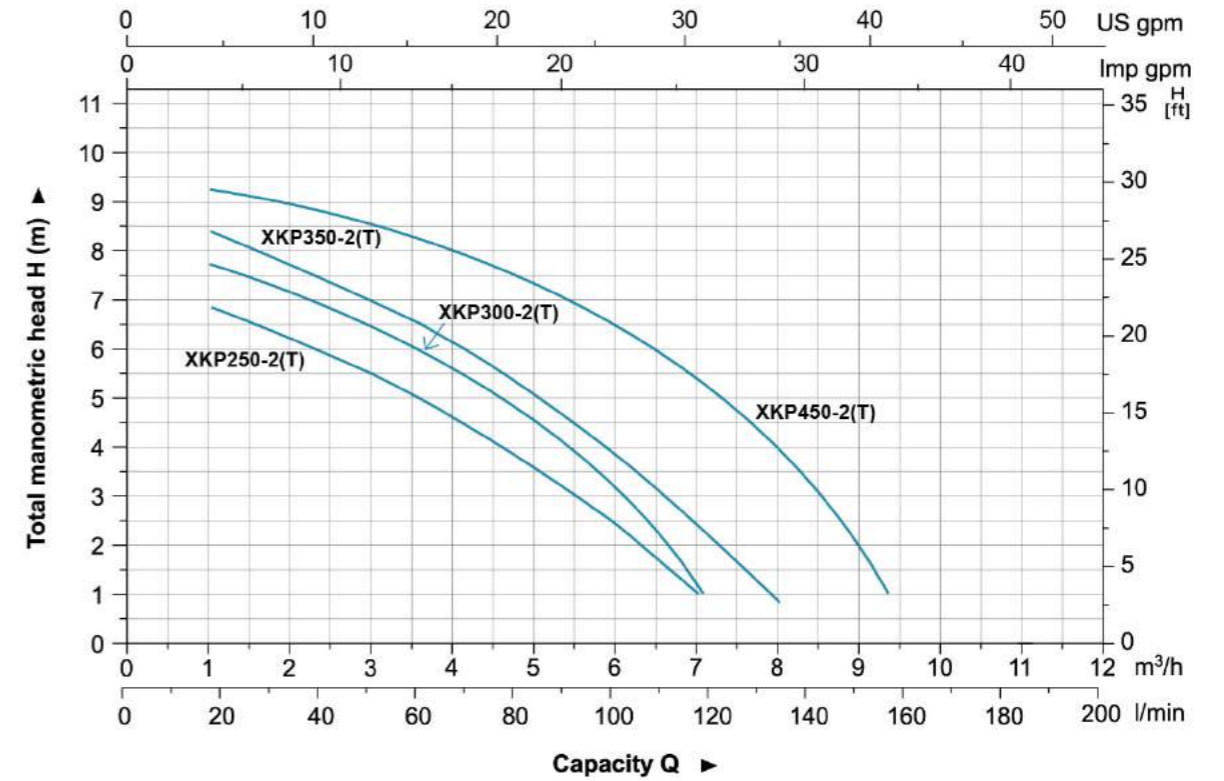

### Materials Table

No.	Part	Material	No.	Part	Material
1	Filling plug	PP	14	Terminal box	ABS
2	Pump body	PP	15	Terminal board	PC
3	Water proof cover	PPO	16	Terminal box cover	ABS
4	Diffuser	PPO	17	Capacitor	
5	Ball bearing		18	Front plate	ZL102
6	Rotor		19	Support	PP
7	Base	PA	20	O-ring	NBR
8	Stator		21	Mechanical seal	Graphite/Ceramics
9	Fan cover	08F	22	Impeller	PPO
10	Fan	PP	23	Sieve	PP
11	Rear cover	ZL102	24	O-ring	NBR
12	Motor housing	ZL102	25	Nut	ABS
13	Cable		26	Connector	PC

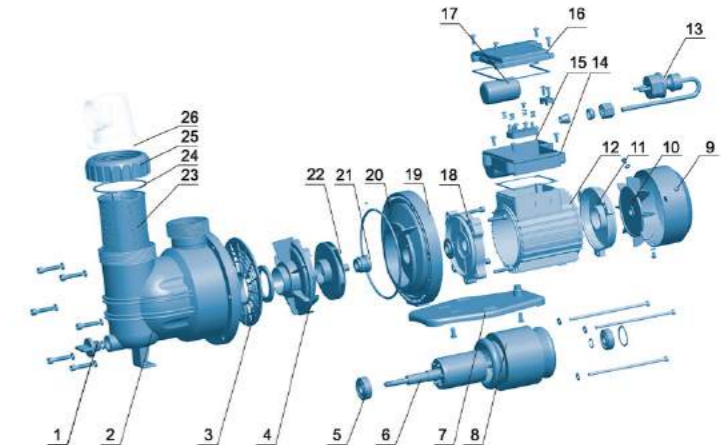

### Package Information

Model	GW (Kgs)	L (mm)	W (mm)	H (mm)	Quantity (PCS/20 TEU)
XKP250-2(T)	5.6	450	203	238	1341
XKP300-2(T)	6.0	450	203	238	1341
XKP350-2(T)	6.2	450	203	238	1341
XKP450-2(T)	6.4	450	203	238	1341







### Application

- It is used for water circulation in small and medium-sized swimming pools. Slightly dirty water with solids in suspension can be perfectly filtered.

### Pump

- Engineering plastic pump body
- Max. liquid temperature: +35°C
- Max. suction: 3.5 m

### Motor

- Motor with copper or aluminum winding
- Built-in thermal protector for single phase motor
- Insulation class: F
- Protection class: IPX5

### Identification Codes

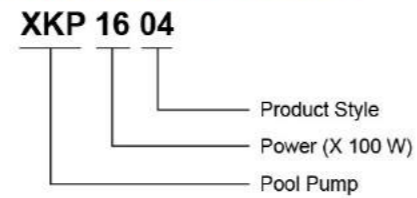

### Technical Data

MODEL	POWER (P <sub>1</sub> ) W	Q (m <sup>3</sup> /h) Q (l/min)	H (m)													
			3	6	9	12	15	18	21	24	27	30				
XKP554	600		9.7	9	8	6	3.2	0.5	-	-	-	-	-	-	-	-
XKP804	800		10.8	10.3	8.8	7	4.5	1.5	-	-	-	-	-	-	-	-
XKP904	900		13.2	12.3	11.1	9.2	6.5	3.4	0.2	-	-	-	-	-	-	-
XKP1104	1100		14.8	14.2	13.2	12	10.3	8	4.8	-	-	-	-	-	-	-
XKP1604	1600		16.8	16.3	15.5	14.5	13.5	12	9.6	7	3.5	-	-	-	-	-
XKP2204	2200		17.8	17.3	16.5	16	14.8	13.4	11.7	9.5	6.5	3.3	-	-	-	-

### Hydraulic Performance Curves

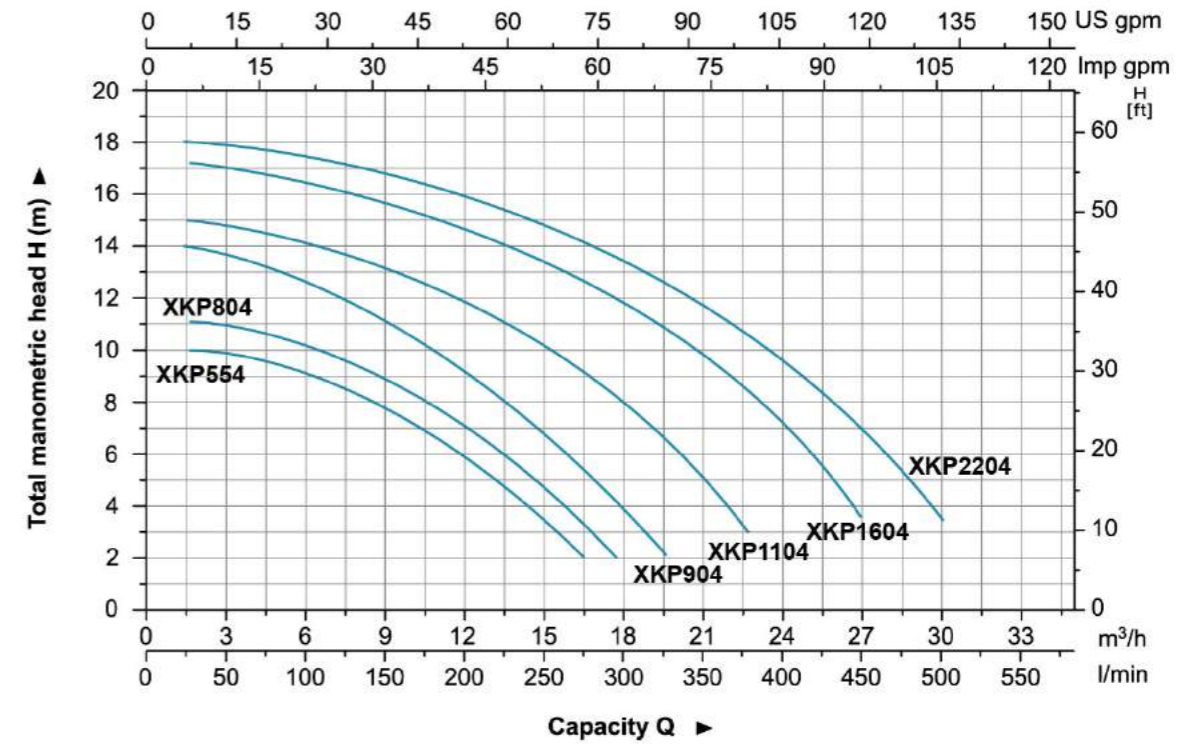

### Materials Table

No.	Part	Material	No.	Part	Material
1	Drain plug	PP	16	Rear cover	ZL102
2	O-ring	NBR	17	Capacitor cover	ABS
3	Valve body	PP	18	Capacitor	
4	Pump body	PP	19	Terminal box	ABS
5	Diffuser seal washer	NBR	20	Stator	
6	Diffuser	PP	21	Bearing	
7	Impeller	PPO	22	Rotor	
8	Mechanical seal	Graphite/Ceramics	23	O-ring	NBR
9	O-ring	NBR	24	Connector	PVC
10	Bottom board	PP	25	Nut	ABS
11	Plastic support	PP	26	O-ring	EPDM
12	Pump support	ZL102	27	Sieve	PP
13	Fan cover	PP	28	Pump cover	PC
14	Fan	PP	29	Pump cover nut	PA6
15	Cable		30	Wrench	PP

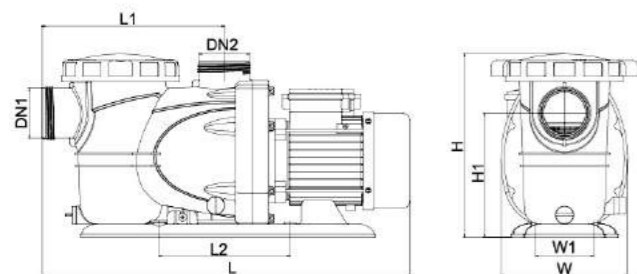
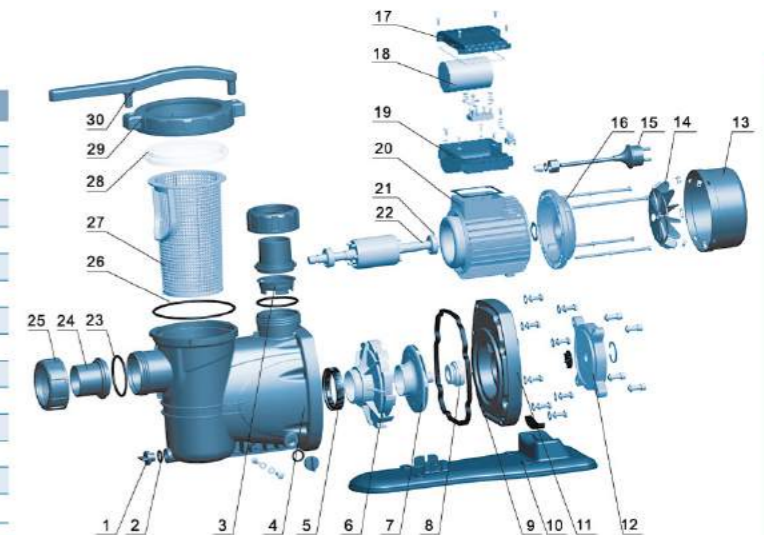

### Dimension

Model	DN1	DN2	L (mm)	W (mm)	H (mm)	L1 (mm)	L2 (mm)	H1 (mm)
XKP554			554	190	276	274	197	187
XKP804			554	190	276	274	197	187
XKP904			554	190	276	274	197	187
XKP1104			554	190	276	274	197	187
XKP1604			584	190	276	274	197	187
XKP2204			584	190	276	274	197	187

### Package Information

Model	GW (Kgs)	L (mm)	W (mm)	H (mm)	Quantity (PCS/20 TEU)
XKP554	10.4	585	220	290	816
XKP804	11.1	585	220	290	816
XKP904	12.1	585	220	290	816
XKP1104	12.8	585	220	290	816
XKP1604	16.1	615	230	290	744
XKP2204	17.7	615	230	290	744







### Application

- Can be used to transfer clean or slightly dirty water or other liquids similar to water in physical and chemical properties
- Suitable to be immersed in water for lifting water from the well or the pool, and draining water from the basement

### Pump

- Engineering plastic pump body
- Extensive use with two outlets
- Float switch ensures automatic cut-in and cut-out
- Max. liquid temperature: +35°C
- Max. immersion depth: 7 m
- Max. diameter of particle: 5 mm

### Motor

- Motor with aluminum winding
- Built-in thermal protector
- Insulation class: F
- Protection class: IPX8

### Identification Codes

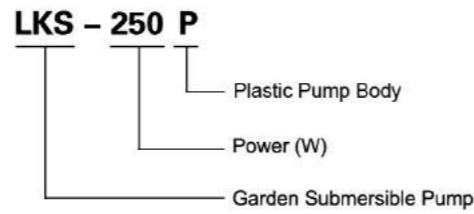

### Technical Data

MODEL	POWER		Q (m³/h)	H (m)											
	W	HP		Q (l/min)	0.9	1.5	3	4.5	6	7.5	9	10.5	12	12.6	
LKS-250P	250	0.3	15	5.8	5.3	4.1	3	1.7	-	-	-	-	-	-	
LKS-400P	400	0.5	25	6.5	6.1	5.1	4	3	1.8	-	-	-	-	-	
LKS-500P	500	0.7	50	7.6	7.4	6.8	6	5.2	4.3	3	1.5	-	-	-	
LKS-750P	750	1	75	8.7	8.5	8	7.4	6.7	5.8	4.8	3.5	2.2	-	-	
LKS-1000P	1000	1.3	100	11.6	11.3	10.5	9.7	8.8	7.6	6.3	4.6	2.9	2	-	

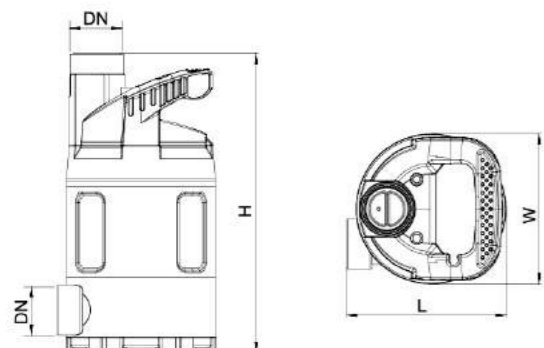

### Dimension

Model	DN	L (mm)	W (mm)	H (mm)
LKS-250P	32	157	148	295
LKS-400P		157	148	295
LKS-500P		157	148	316
LKS-750P		157	148	316
LKS-1000P		157	148	353

### Hydraulic Performance Curves

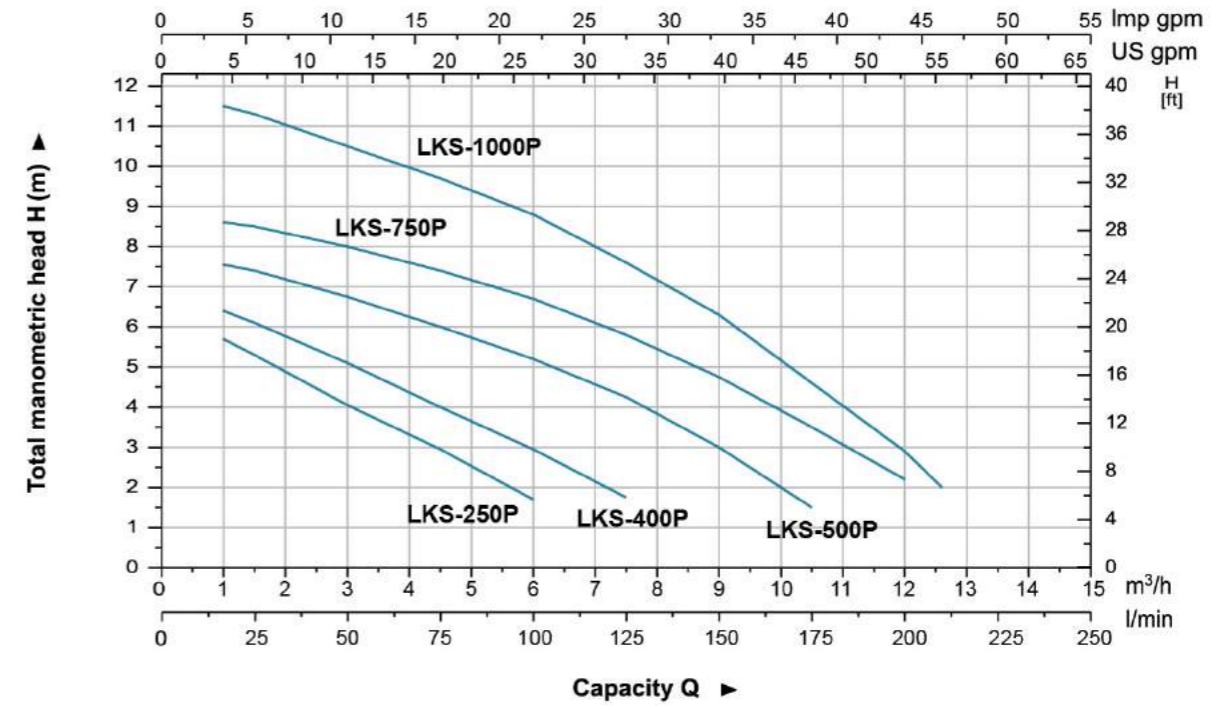

### Materials Table

No.	Part	Material	No.	Part	Material
1	Handle	PP	14	Wire jacket	NBR
2	Cable	Rubber	15	Upper cover	
3	Plug	PP	16	Bearing	
4	Nut	PP	17	Rotor	
5	Cable jacket	EPDM	18	Stator	
6	Roof	PP	19	Lip seal	
7	Capacitor clip	PC/ABS	20	Bearing seat	ZL102
8	Capacitor		21	O-ring	NBR
9	Retainer ring	PP	22	Stator cover	Steel
10	Pump body	PP	23	Lip seal	
11	Base plate	PP	24	O-ring	NBR
12	Base	PP	25	Impeller	PA6
13	Float switch	PP	26	Nut	Stainless steel

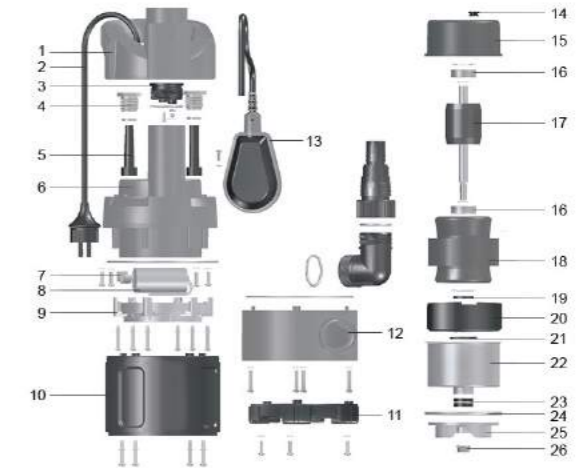

### Package Information

Model	GW (Kgs)	L (mm)	W (mm)	H (mm)	Quantity (PCS/20 TEU)
LKS-250P	4.4	210	160	330	2064
LKS-400P	4.6	210	160	330	2064
LKS-500P	5.2	210	160	330	2064
LKS-750P	6	210	160	330	2064
LKS-1000P	6.4	210	160	370	1720







### Application

- Can be used to transfer clean or slightly dirty water or other liquids similar to water in physical and chemical properties
- Suitable to be immersed in water for lifting water from the well or the pool, and draining water from the basement

### Pump

- Engineering plastic pump body
- Extensive use with two outlets
- Max. liquid temperature: +35°C
- Float switch ensures automatic cut-in and cut-out
- Max. immersion depth: 7 m
- Max. diameter of particle: 25 mm

### Motor

- Motor with aluminum winding
- Built-in thermal protector
- Insulation class: F
- Protection class: IPX8

### Identification Codes

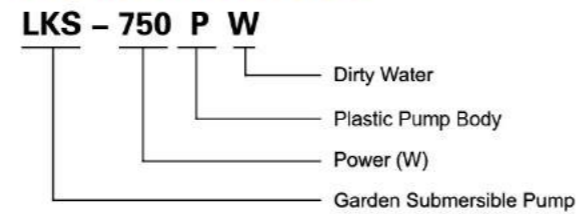

### Technical Data

MODEL	POWER		Q (m <sup>3</sup> /h)	H (m)											
	W	HP		Q (l/min)	0.9	1.5	3	4.5	6	7.5	9	10.5	12	12.6	
LKS-250PW	250	0.3		4.1	3.8	3	2.2	1.4	-	-	-	-	-	-	
LKS-400PW	400	0.5		4.7	4.5	3.8	3.1	2.3	1.3	-	-	-	-	-	
LKS-500PW	500	0.7		6.8	6.7	6.1	5.5	4.6	3.7	2.6	1.4	-	-	-	
LKS-750PW	750	1		7.9	7.7	7.2	6.6	5.8	5.1	4.2	3.2	2	-	-	
LKS-1000PW	1000	1.3		10.6	10.3	9.4	8.4	7.5	6.5	5.4	4.1	2.6	1.9	-	

### Hydraulic Performance Curves

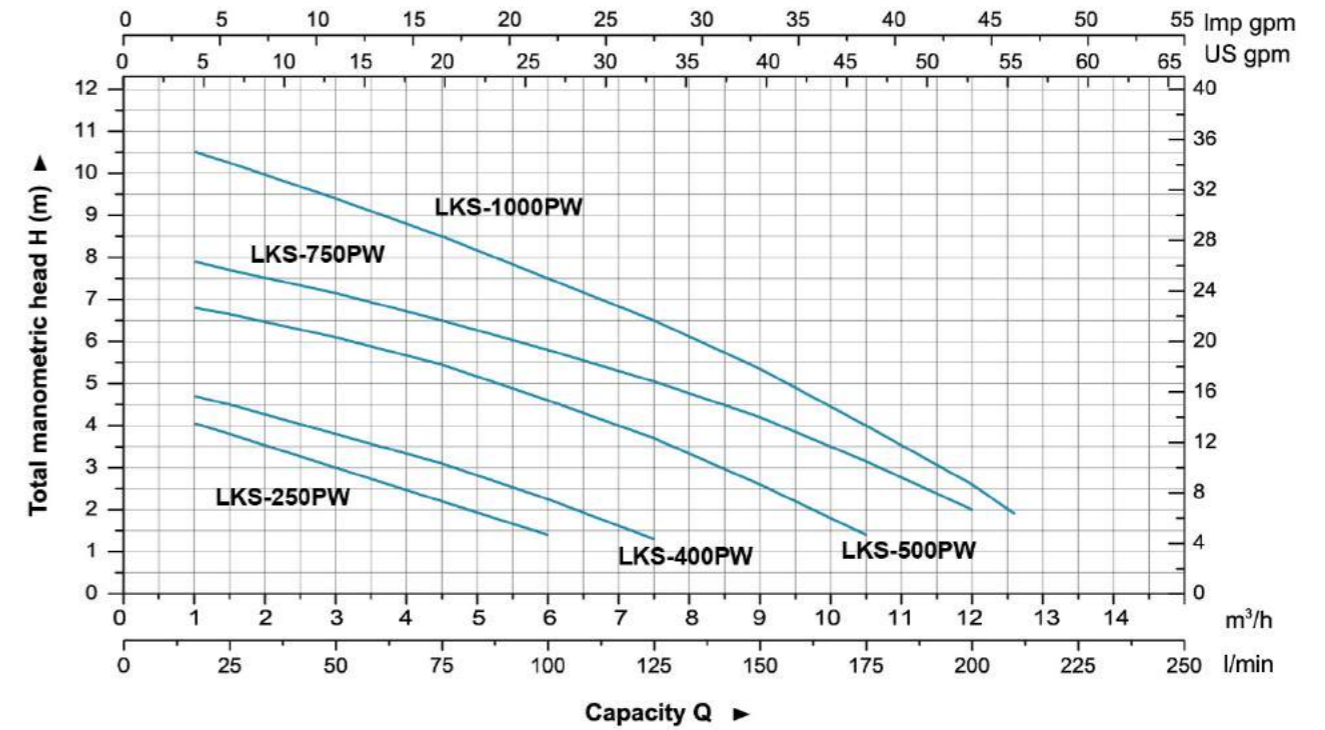

### Materials Table

No.	Part	Material	No.	Part	Material
1	Handle	PP	14	Wire jacket	NBR
2	Cable	Rubber	15	Upper cover	
3	Plug	PP	16	Bearing	
4	Nut	PP	17	Rotor	
5	Cable jacket	EPDM	18	Stator	
6	Roof	PP	19	Lip seal	
7	Capacitor clip	PC/ABS	20	Bearing seat	ZL102
8	Capacitor		21	O-ring	NBR
9	Retainer ring	PP	22	Stator cover	Steel
10	Pump body	PP	23	Lip seal	
11	Base plate	PP	24	O-ring	NBR
12	Base	PP	25	Impeller	PA6
13	Float switch	PP	26	Nut	Stainless steel

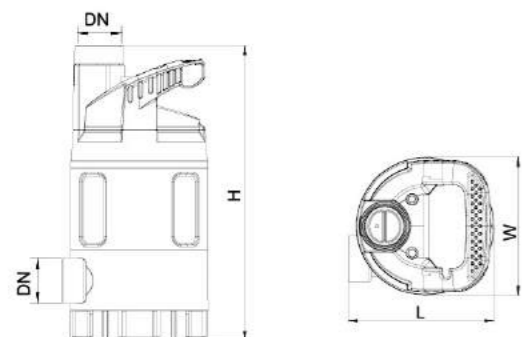
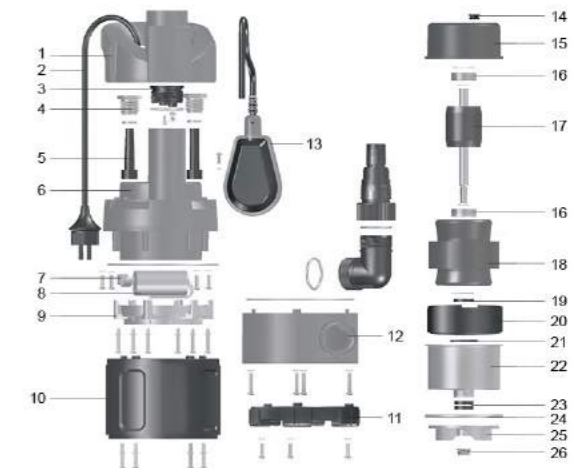

### Dimension

Model	DN	L (mm)	W (mm)	H (mm)
LKS-250PW	32	157	148	318
LKS-400PW		157	148	318
LKS-500PW		157	148	339
LKS-750PW		157	148	339
LKS-1000PW		157	148	371

### Package Information

Model	GW (Kgs)	L (mm)	W (mm)	H (mm)	Quantity (PCS/20 TEU)
LKS-250PW	4.5	210	160	370	2064
LKS-400PW	4.8	210	160	370	2064
LKS-500PW	5.0	210	160	370	2064
LKS-750PW	6.1	210	160	350	2064
LKS-1000PW	7.7	210	160	380	1720







### Application

- Can be used to transfer dirty water or other liquids similar to water in physical and chemical properties
- Suitable to be immersed in water for lifting water from the well or the pool, and draining water from the basement.
- Specially applicable for small space where water needs to be pumped.

### Pump

- Engineering plastic pump body
- Extensive use with two outlets
- Max.liquid temperature: +35°C
- Innovative electronic water sensor switch ensures automatic cut-in and cut-out
- Max. immersion depth: 7 m
- Max. diameter of particle: 5 mm

### Motor

- Motor with aluminum winding
- Built-in thermal protector
- Insulation class: F
- Protection class: IPX8

### Identification Codes

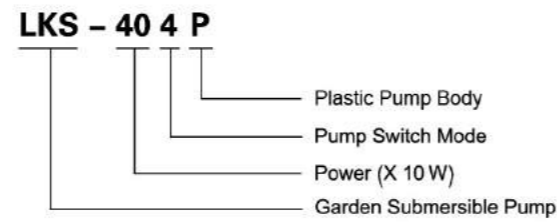

### Technical Data

MODEL	POWER		Q (m³/h)	0.9	1.5	3	4.5	6	7.5	9	10.5	12	12.6
	W	HP		Q (l/min)	15	25	50	75	100	125	150	175	200
LKS-404P	400	0.5	<b>H (m)</b>	6.5	6.1	5.1	4	3	1.8	-	-	-	-
LKS-504P	500	0.7		7.6	7.4	6.8	6	5.2	4.3	3	1.5	-	-
LKS-754P	750	1		8.7	8.5	8	7.4	6.7	5.8	4.8	3.5	2.2	-
LKS-1004P	1000	1.3		11.6	11.3	10.5	9.7	8.8	7.6	6.3	4.6	2.9	2

### Hydraulic Performance Curves

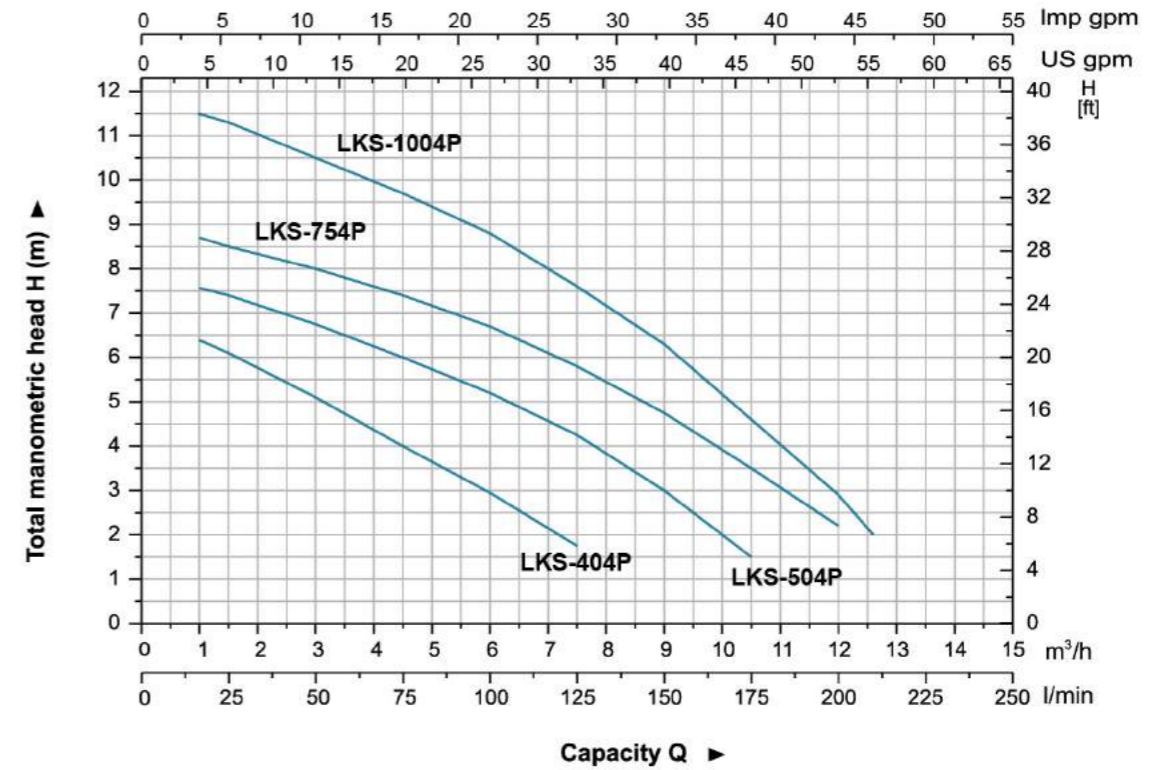

### Materials Table

No.	Part	Material	No.	Part	Material
1	Handle	PP	14	Inductor	
2	Cable	Rubber	15	Controller	
3	Plug	PP	16	Upper cover	
4	Nut	PP	17	Bearing	
5	Cable jacket	EPDM	18	Rotor	
6	Roof	PP	19	Stator	
7	Capacitor clip	PC/ABS	20	Lip seal	
8	Capacitor		21	Bearing seal	ZL102
9	Retainer ring	PP	22	O-ring	NBR
10	Pump body	PP	23	Stator cover	Steel
11	Base plate	PP	24	Lip seal	
12	Base	PP	25	O-ring	NBR
13	Inductor cover	PP	26	Impeller	PA6
			27	Nut	Stainless steel

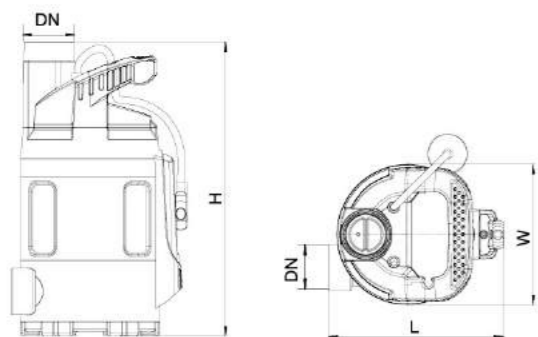
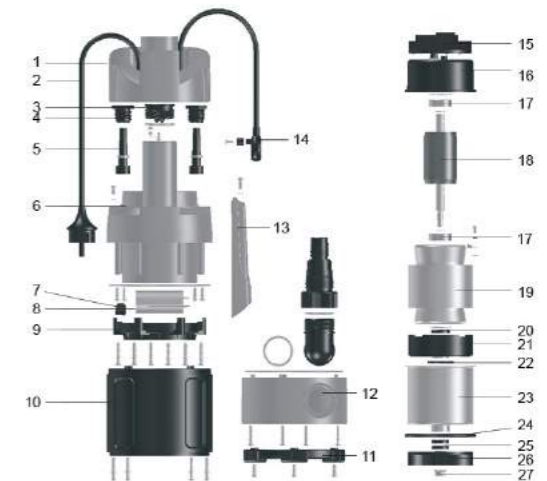

### Dimension

Model	DN	L (mm)	W (mm)	H (mm)
LKS-404P	32	157	148	311
LKS-504P		157	148	332
LKS-754P		157	148	332
LKS-1004P		187	148	364

### Package Information

Model	GW (Kgs)	L (mm)	W (mm)	H (mm)	Quantity (PCS/20 TEU)
LKS-404P	4.8	210	160	340	2064
LKS-504P	5.4	210	160	340	2064
LKS-754P	6.2	210	160	340	2064
LKS-1004P	7	210	160	370	1720







### Application

- This pump is mainly used for use in traditional wells, water deposits and collection tanks. Also suitable for small scale irrigation systems.

### Pump

- AISI 304 pump body
- Very high head with multistage-impeller design
- Max. liquid temperature: +35°C
- Max. immersion depth: 7 m
- Max. diameter of particle: 1 mm

### Motor

- Motor with aluminum winding
- Built-in thermal protector
- Insulation class: F
- Protection class: IPX8

### Identification Codes

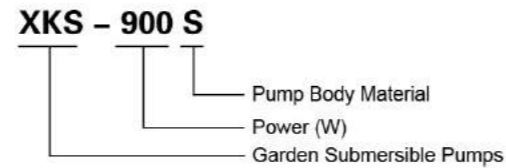

### Technical Data

MODEL	POWER (P <sub>2</sub> )		Q (m <sup>3</sup> /h)	Q (l/min)														
	W	HP		0.5	1	1.5	2	2.5	3	3.5	4	4.5	5	5.5	6	6.5		
XKS-900S	900	1.2	H (m)	8.3	16.7	25	33.3	41.7	50	58.3	66.7	75	83.3	91.7	100	108.3		
XKS-1100S	1100	1.5		34	32	31	29	27.5	26.6	23.5	21	18	15	12	8	3.5		
				45	43	42	39	37	35	32	29	25	21	16.1	12	7		

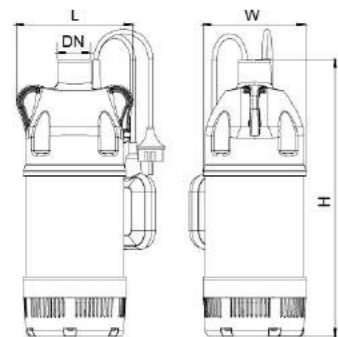

### Dimension

Model	DN	L (mm)	W (mm)	H (mm)
XKS-900S	25	170	150	404
XKS-1100S		170	150	428

### Hydraulic Performance Curve

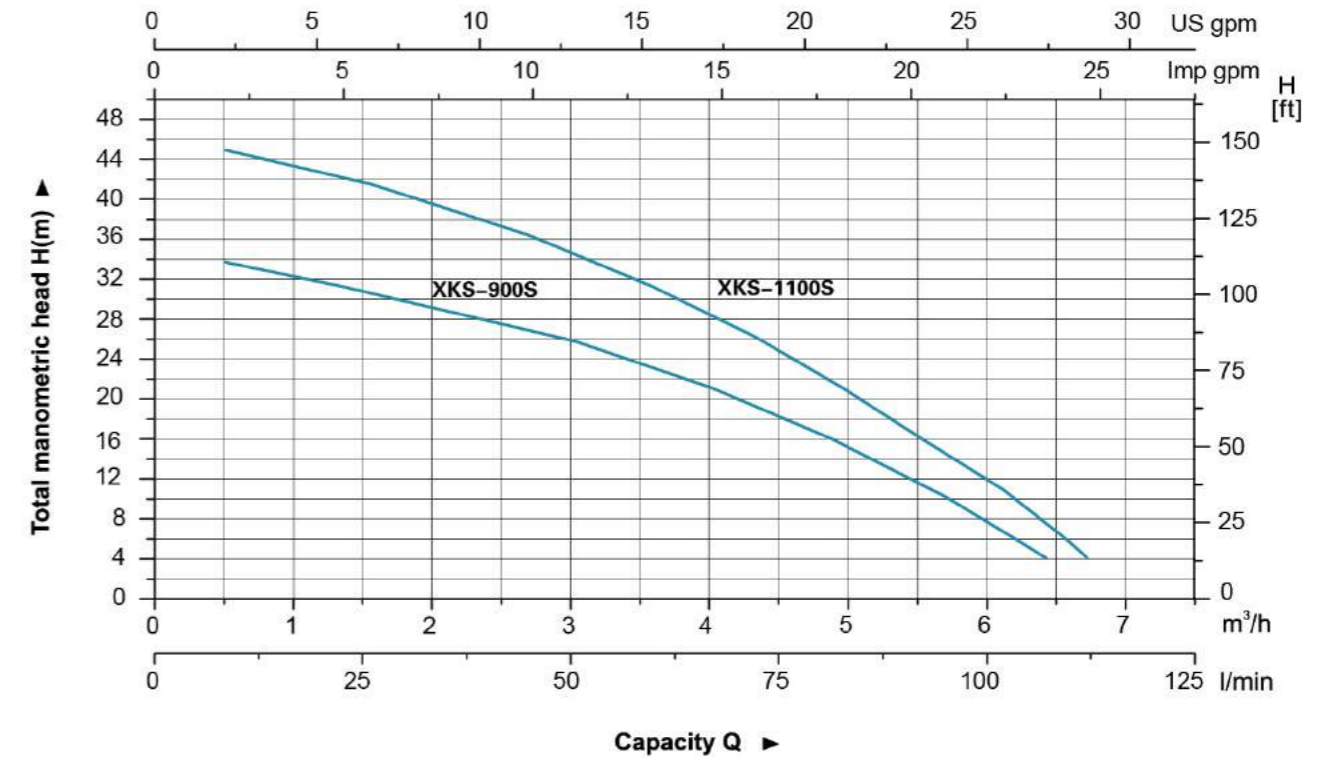

### Materials Table

No.	Part	Material
1	Pump cover	PP
2	Float switch	
3	Cover	PP
4	Capacitor	
5	Upper plate	ZL102
6	O-ring	NBR
7	Bearing	
8	Rotor	
9	Oil seal	
10	Stator	
11	Mechanical seal	Carbon/ceramic
12	Base	PA66
13	Filter screen	AISI 304
14	Impeller	PPO
15	Discharge cover	PPO
16	Diffuser	PPO
17	Seal ring	NBR
18	Pump body	AISI 304

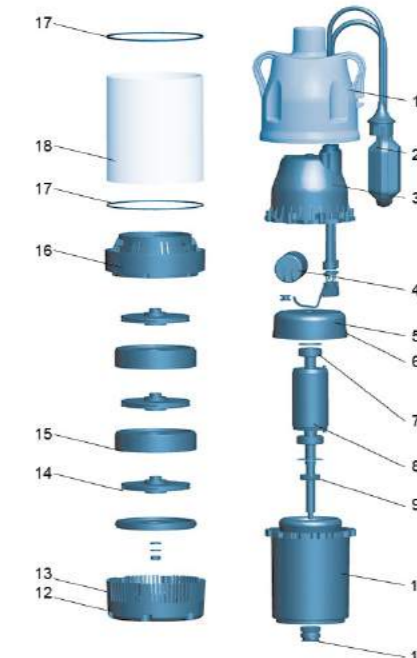

### Package Information

Model	GW (Kgs)	L (mm)	W (mm)	H (mm)	Quantity (PCS/20 TEU)
XKS-900S	9.9	245	190	455	1380
XKS-1100S	11	245	190	480	1104





### Application

- Can be used to transfer clean or slightly dirty water or other liquids similar to water in physical and chemical properties
- Suitable to be immersed in water for lifting water from the well or the pool, and draining water from the basement

### Pump

- Engineering plastic pump body
- Float switch ensures automatic cut-in and cut-out
- Max. liquid temperature: +35°C
- Max. immersion depth: 7 m
- Max. diameter of particle: 5 mm

### Motor

- Motor with aluminum winding
- Built-in thermal protector
- Insulation class: F
- Protection class: IPX8

### Identification Codes

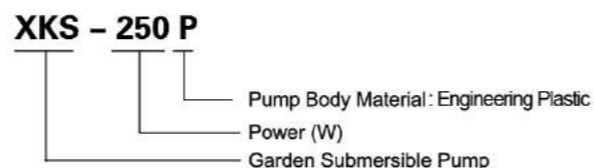

### Technical Data

MODEL	POWER		Q (m <sup>3</sup> /h)	H (m)										
	W	HP		0	1.5	3	4.5	6	7.5	9	10.5			
XKS-250P	250	0.3	0	5.8	5	3.8	2.4	-	-	-	-	-	-	-
XKS-400P	400	0.5	0	6.5	5.8	4.7	3.7	2.6	1.5	-	-	-	-	-
XKS-500P	500	0.7	0	7.6	7.6	6.8	5.7	4.7	3.6	2.3	-	-	-	-
XKS-750P	750	1	0	8.7	8.5	7.7	7.2	6.2	5.5	4.5	3.2	-	-	-

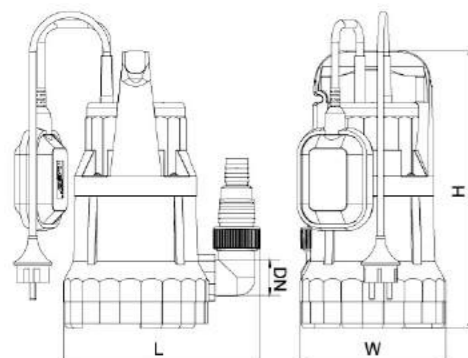

### Dimension

Model	DN	L (mm)	W (mm)	H (mm)
XKS-250P	32	213	158	300.5
XKS-400P		213	158	300.5
XKS-500P		213	158	300.5
XKS-750P	40	213	158	317.5

### Hydraulic Performance Curves

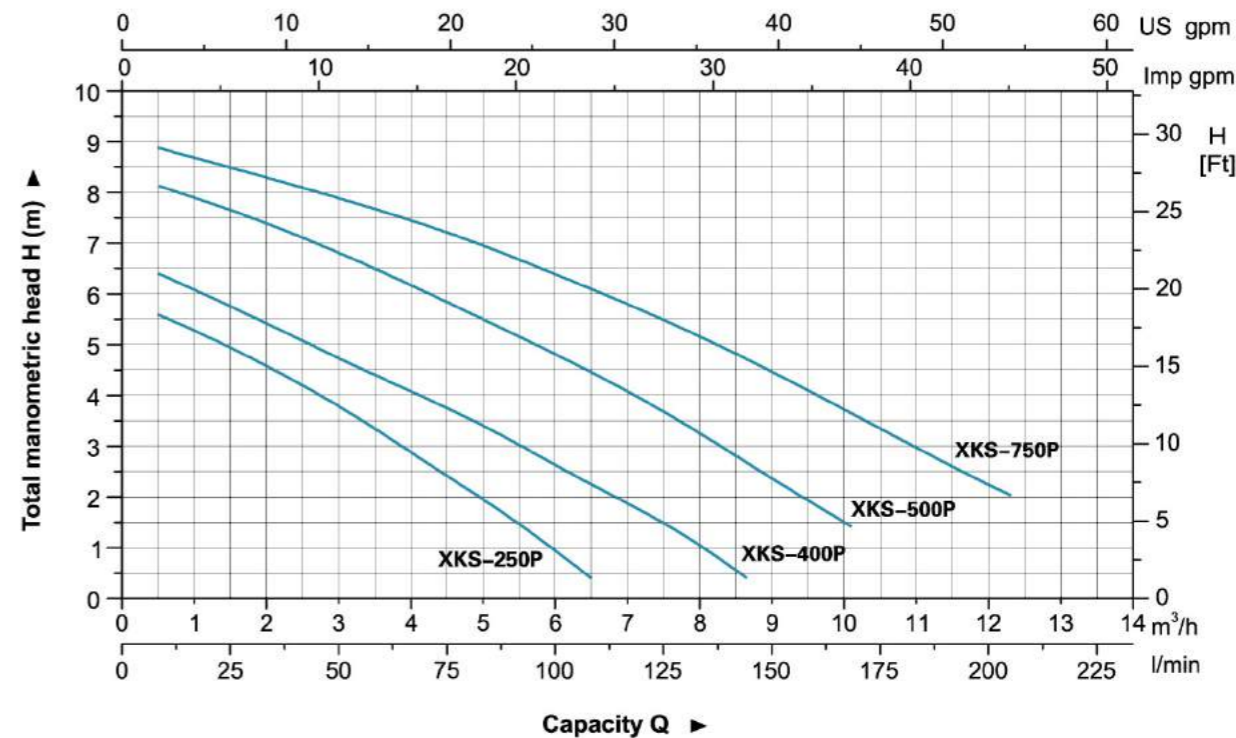

### Materials Table

Pos.	Part	Material
1	Pump base	PP
2	Pump body	PP
3	Capactor	
4	Cable	
5	Roof	PP
6	Float switch	
7	Upper cover	
8	Stator	
9	Bearing	
10	Rotor	
11	Lip seal	
12	Bearing seat	DMC
13	O-ring	NBR
14	Stator shield	Steel
15	O-ring	NBR
16	Lip seal	
17	Impeller	PA6
18	Nut	AISI 304

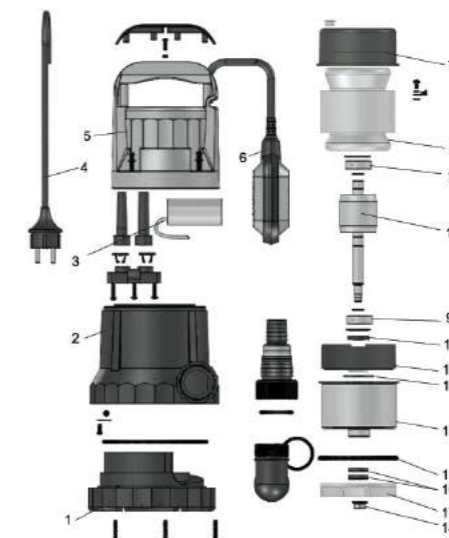

### Package Information

Model	GW (Kgs)	L (mm)	W (mm)	H (mm)	Quantity (PCS/20 TEU)
XKS-250P	4.8	210	160	340	2064
XKS-400P	5.1	210	160	330	2064
XKS-500P	5.5	210	160	340	2064
XKS-750P	6.0	210	160	340	2064







### Application

- Can be used to transfer clean or slightly dirty water or other liquids similar to water in physical and chemical properties
- Suitable to be immersed in water for lifting water from the well or the pool, and draining water from the basement

### Pump

- Stainless steel pump body
- Float switch ensures automatic cut-in and cut-out
- Max. liquid temperature: +35°C
- Max. immersion depth: 7 m
- Max. diameter of particle: 5 mm

### Motor

- Motor with aluminum winding
- Built-in thermal protector
- Insulation class: F
- Protection class: IPX8

### Identification Codes

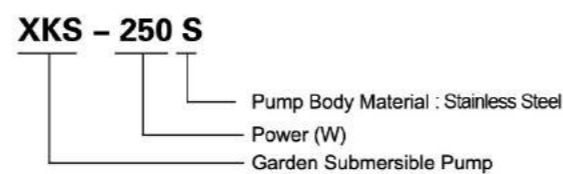

### Technical Data

MODEL	POWER		Q (m <sup>3</sup> /h)	Q (l/min)	H (m)											
	W	HP			0	2	4	6	8	10	12					
XKS-250S	250	0.3	H (m)	0	33	67	100	133	167	200						
XKS-400S	400	0.5		5.5	3.8	2.3	-	-	-	-	-					
XKS-500S	500	0.7		6.3	5.5	4.5	3	2	-	-	-					
XKS-750S	750	1		7.5	6.5	5.3	4	2.5	-	-	-					
XKS-1000S	1000	1.3		8.5	7.8	6.8	5.5	4	2.3	-	-					
				11.5	10.6	9.5	8	6	4	1.9						

### Hydraulic Performance Curves

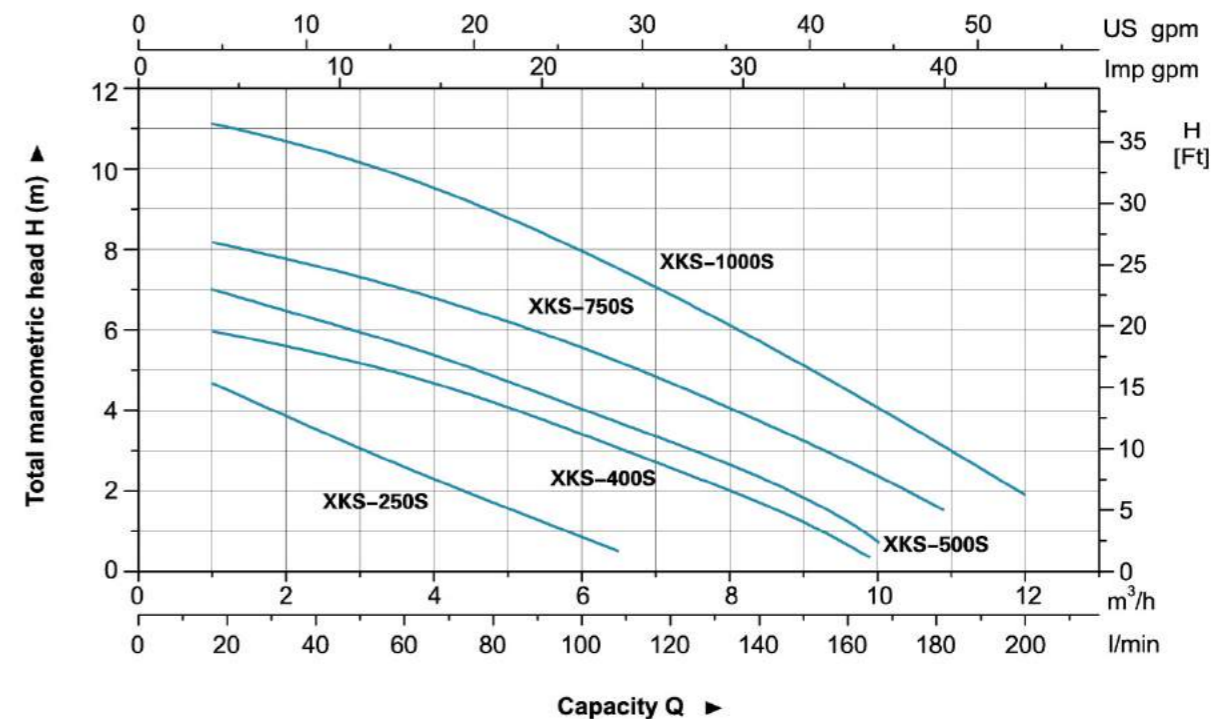

### Materials Table

No.	Part	Material
1	Pump cover	AISI 304
2	Float switch	
3	Upper cover	PP
4	Capacitor	
5	Upper plate	ZL102
6	Pump base	AISI 304
7	Diffuser	PP
8	Impeller	PPO
9	Mechanical seal	Carbon/Ceramic
10	Pump support	ABS
11	Stator	
12	Ball bearing	
13	Rotor	
14	Connector	PP
15	Connector	PP

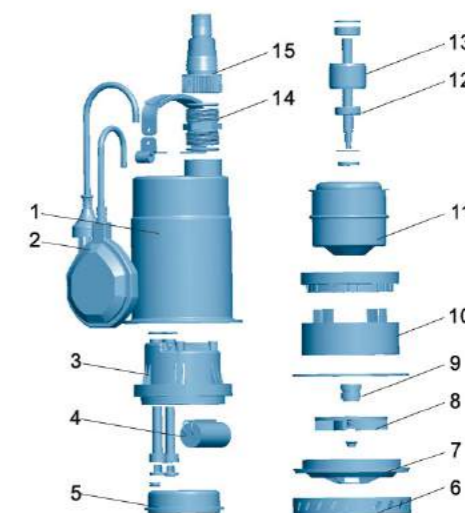

### Package Information

Model	GW (Kgs)	L (mm)	W (mm)	H (mm)	Quantity (PCS/20 TEU)
XKS-250S	4.8	200	150	300	2632
XKS-400S	5.2	200	150	300	2632
XKS-500S	6.2	200	150	300	2632
XKS-750S	7.8	205	155	345	2160
XKS-1000S	7	205	155	345	2256

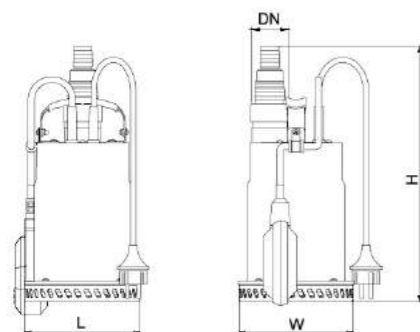

### Dimension

Model	DN	L (mm)	W (mm)	H (mm)
XKS-250S	32	151	151	323
XKS-400S		151	151	323
XKS-500S		151	151	331
XKS-750S		151	151	347
XKS-1000S		151	151	326





### Application

- Can be used to transfer clean or slightly dirty water or other liquids similar to water in physical and chemical properties
- Suitable to be immersed in water for lifting water from the well or the pool, and draining water from the basement

### Pump

- Engineering plastic pump body
- Max. liquid temperature: +35°C
- Float switch ensures automatic cut-in and cut-out
- Max. immersion depth: 7 m
- Max. diameter of particle: 35 mm

### Motor

- Motor with aluminum winding
- Built-in thermal protector
- Insulation class: F
- Protection class: IPX8

### Identification Codes

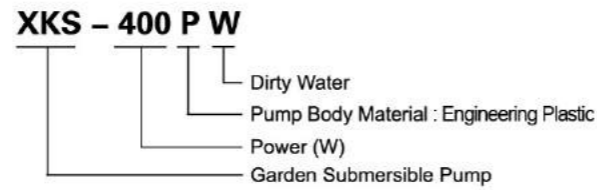

### Technical Data

MODEL	POWER		Q (m³/h)	H (m)												
	W	HP		0	1.5	3	4.5	6	7.5	9	10.5	12	13.5			
XKS-400PW	400	0.5	4.8	4.3	3.5	2.8	2	1.3	-	-	-	-	-	-		
XKS-550PW	550	0.7	7	6.4	5.7	5.2	4.6	3.5	2.5	1.5	-	-	-	-		
XKS-750PW	750	1	8.2	7.5	7	6.5	5.6	4.8	3.8	2.8	1.5	-	-	-		
XKS-1000PW	1000	1.3	10.5	9.7	9	8.3	7.5	6.7	5.8	5	4	3	-	-		

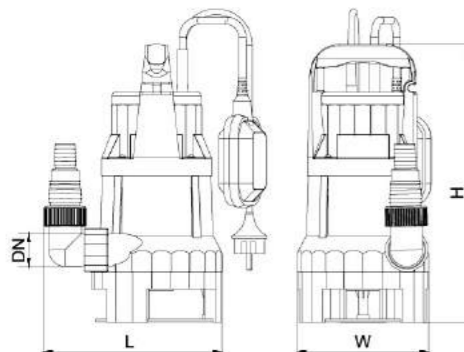

### Dimension

Model	DN	L (mm)	W (mm)	H (mm)
XKS-400PW	32	213	158	332
XKS-550PW	32	213	158	349
XKS-750PW	40	213	158	349
XKS-1000PW		217	153	376

### Hydraulic Performance Curves

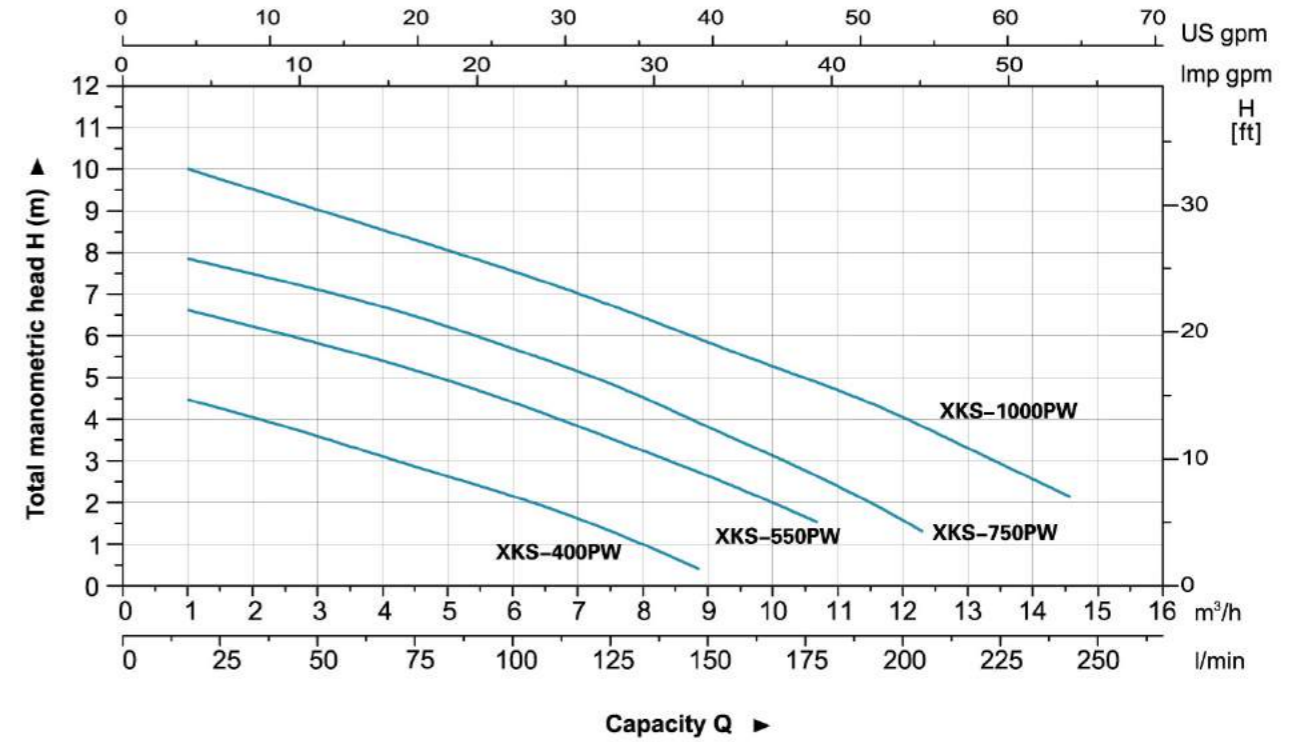

### Materials Table

Pos.	Part	Material
1	Base plate	PP
2	Pump base	PP
3	Pump body	PP
4	Capacitor	
5	Cable	
6	Roof	PP
7	Float switch	
8	Upper cover	
9	Stator	
10	Bearing	
11	Rotor	
12	Lip seal	
13	Bearing seat	DMC
14	O-ring	NBR
15	Stator shield	Steel
16	O-ring	NBR
17	Lip seal	
18	Impeller	PA6
19	Nut	AISI 304

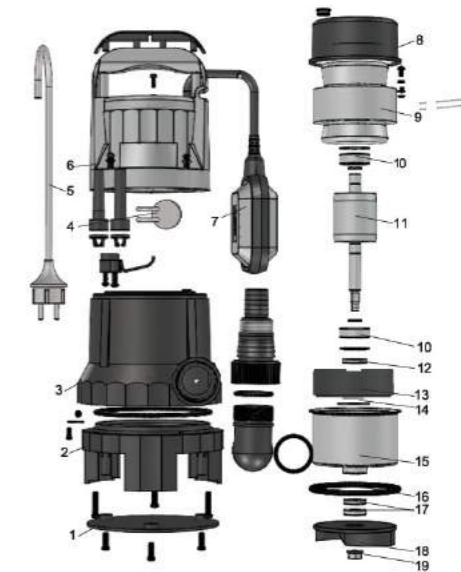

### Package Information

Model	GW (Kgs)	L (mm)	W (mm)	H (mm)	Quantity (PCS/20 TEU)
XKS-400PW	4.8	210	160	340	2632
XKS-550PW	5.2	210	160	360	2632
XKS-750PW	6.2	210	160	360	2632
XKS-1000PW	7.8	210	160	390	2160







### Application

- Can be used to transfer clean or slightly dirty water or other liquids similar to water in physical and chemical properties
- Suitable to be immersed in water for lifting water from the well or the pool, and draining water from the basement

### Pump

- Stainless steel pump body
- Float switch ensures automatic cut-in and cut-out
- Max. liquid temperature: +35°C
- Max. immersion depth: 7 m
- Max. diameter of particle: 35 mm

### Motor

- Motor with aluminum winding
- Built-in thermal protector
- Insulation class: F
- Protection class: IPX8

### Identification Codes

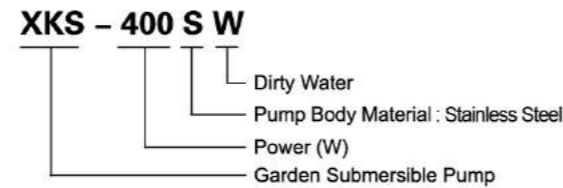

### Technical Data

MODEL	POWER		Q (m <sup>3</sup> /h)	0	2	4	6	8	10	12
	W	HP								
XKS-400SW	400	0.5	H (m)	4.7	3.5	2.5	1.5	-	-	-
XKS-550SW	550	0.7		7	6.2	5.1	3.8	2.5	-	-
XKS-750SW	750	1		8.3	7.3	6.3	5.2	4.2	2.5	-
XKS-1000SW	1000	1.3		10.3	9.3	8.2	7	5.8	4.5	2.8

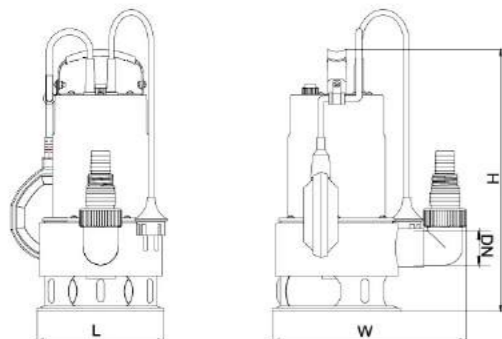

### Dimension

Model	DN	L (mm)	W (mm)	H (mm)
XKS-400SW	40	165	248	340
XKS-550SW		165	248	340
XKS-750SW		165	248	351
XKS-1000SW		165	248	370

### Hydraulic Performance Curves

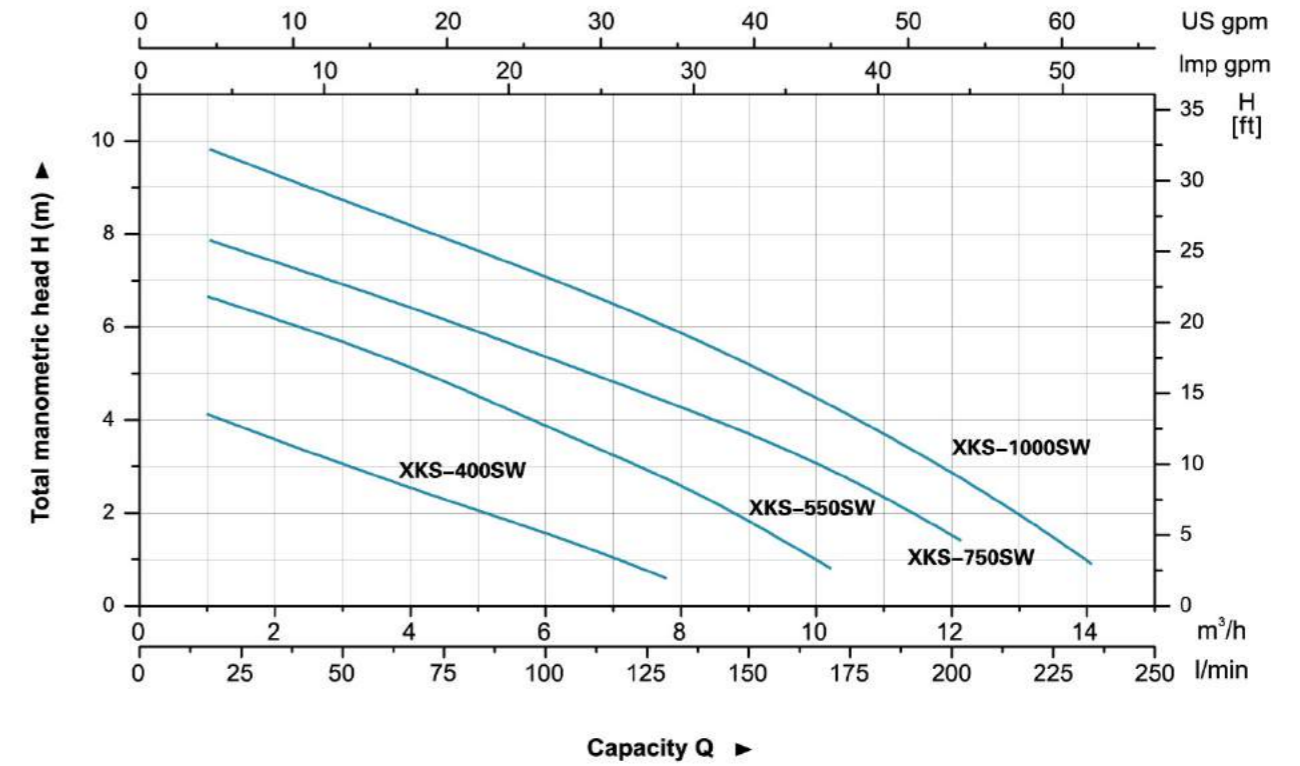

### Materials Table

Pos.	Part	Material
1	Handle	AISI 304
2	Cable	Rubber
3	Pump body	AISI 304
4	Roof	PP
5	Jacket	NBR
6	O-ring	NBR
7	Pump body	AISI 304
8	Capacitor	
9	Float switch	PP
10	Upper cover	
11	Stator	
12	Bearing	
13	Rotor	
14	Lip seal	
15	Bearing base	MPPO
16	O-ring	NBR
17	Canister	Stainless
18	Lip seal	
19	Retainer ring	PP
20	Pump support	ABS
21	Impeller	PA6
22	Nut	AISI 304

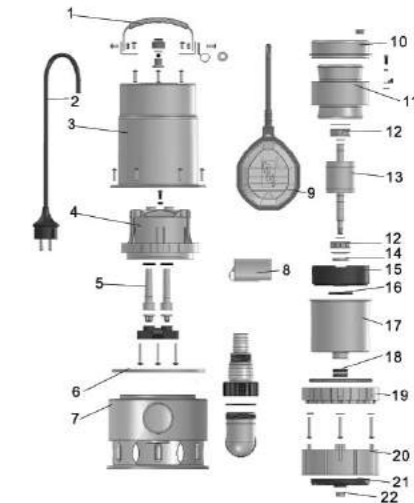

### Package Information

Model	GW (Kgs)	L (mm)	W (mm)	H (mm)	Quantity (PCS/20 TEU)
XKS-400SW	5.7	210	165	350	1968
XKS-550SW	6.4	210	165	350	1968
XKS-750SW	7	210	165	350	1968
XKS-1000SW	8.6	215	170	355	1888







### Application

- Can be used to transfer clean water or other liquids similar to water in physical and chemical properties
- Suitable for water supply and drainage in garden irrigation, greenhouses, fish breeding and poultry raising. The pump also can be used for domestic automatic water supply places, such as lifting water from a deep well, pressure boosting of running water, etc.

### Pump

- Unique ergonomic design
- Max. fluid temperature: +35°C
- Max. suction: +8 m

### Motor

- C&U bearing
- Built-in thermal protector
- Aluminum winding
- Insulation class: F
- Protection class: IPX4
- Max. ambient temperature: +40°C

### Identification Codes

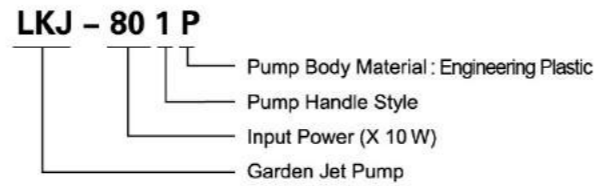

### Technical Data

MODEL	POWER (P <sub>2</sub> )		Q (m <sup>3</sup> /h)	Q (l/min)											
	W	HP		0	0.6	1.2	1.8	2.4	3	3.6	4.2	4.8	5.4	6	
LKJ-601P	600	0.8	<b>H (m)</b>	30	28	25.5	20	14	8	-	-	-	-	-	
LKJ-801P	800	1.1		39	34.5	29	23	16.5	9.5	-	-	-	-	-	

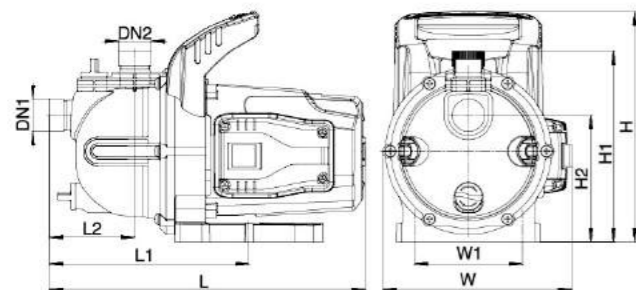

### Dimension

Model	DN1	DN2	L (mm)	W (mm)	H (mm)	L1 (mm)	L2 (mm)	W1 (mm)	H1 (mm)	H2 (mm)
LKJ-601P	1"	1"	350	210	255.5	221.5	94.5	120	211	140.5
LKJ-801P	1"	1"	350	210	255.5	221.5	94.5	120	211	140.5

### Hydraulic Performance Curves

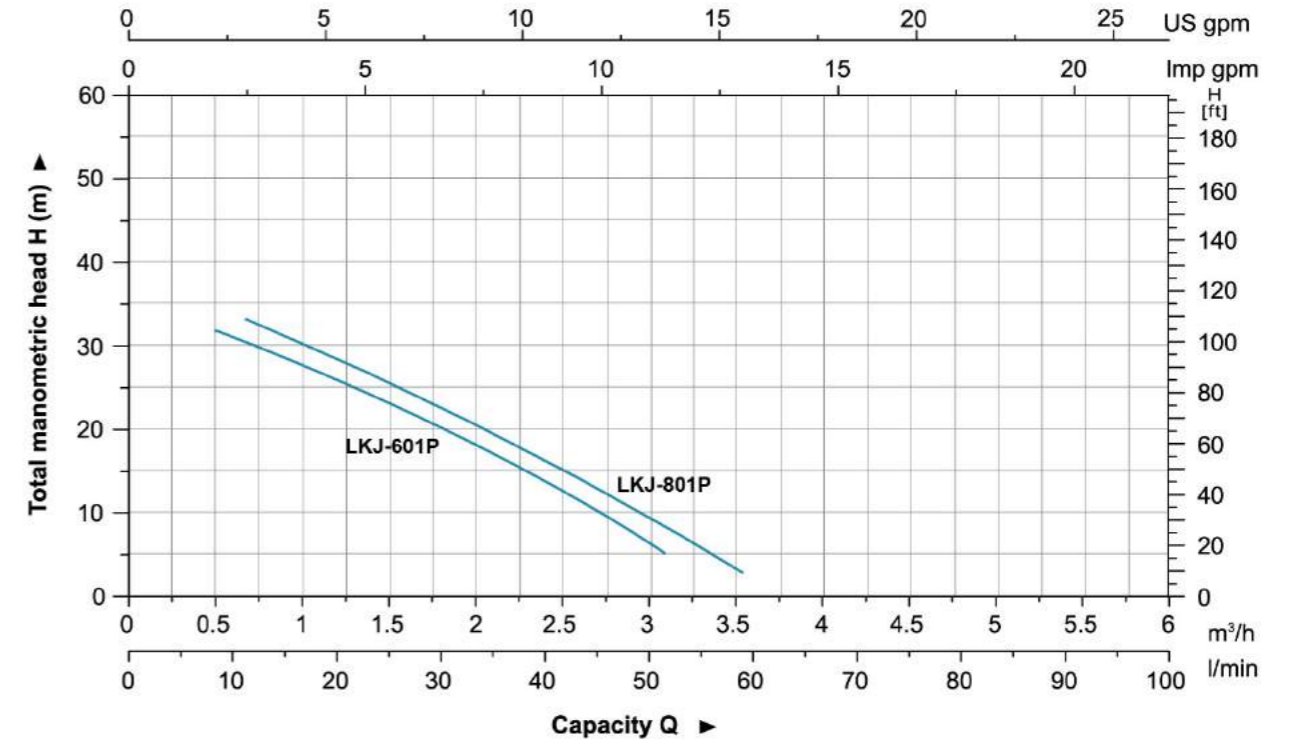

### Materials Table

No.	Part	Material
1	Drain plug	PP
2	Pump body	PP
3	Enjector	PPO
4	Diffuser	PPO
5	Impeller	PPO
6	O-ring	NBR
7	Mechanical seal	Carbon/Ceramic
8	Bracket cover	AISI 304
9	Terminal board	ABS
10	Capacitor	
11	Switch cover	ABS
12	Rotor	
13	Motor flange	PP
14	Front plate	ZL102
15	Stator	
16	Rear cover	ZL102
17	Handle	PP
18	Fan	PP
19	Fan cover	ABS

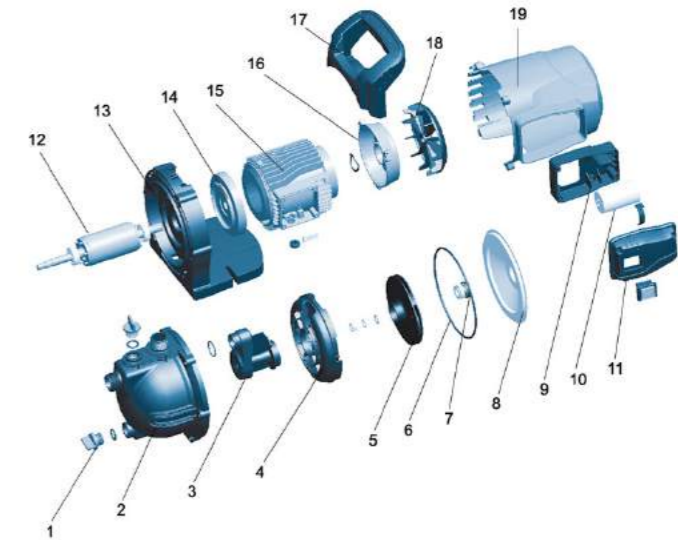

### Package Information

Model	GW (Kgs)	L (mm)	W (mm)	H (mm)	Quantity		
					20'/pcs	40'/pcs	40H'/pcs
LKJ-601P	6.8	375	230	280	1232	2512	2826
LKJ-801P	7.5	375	230	280	1232	2512	2826







### Application

- Can be used to transfer clean water or other liquids similar to water in physical and chemical properties
- Suitable for water supply and drainage in garden irrigation, greenhouses, fish breeding and poultry raising. The pump also can be used for domestic automatic water supply places, such as lifting water from a deep well, pressure boosting of running water, etc.

### Pump

- Unique ergonomic design
- Max. fluid temperature: +35°C
- Max. suction: +8 m

### Motor

- C&U bearing
- Built-in thermal protector
- Aluminum winding
- Insulation class: F
- Protection class: IPX4
- Max. ambient temperature: +40°C

### Identification Codes

**LKJ - 80 1 S**

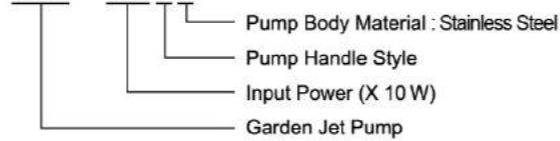

### Technical Data

MODEL	POWER (P <sub>2</sub> )		Q (m <sup>3</sup> /h)	H (m)											
	W	HP		0	0.6	1.2	1.8	2.4	3	3.6	4.2	4.8	5.4	6	
LKJ-601S	600	0.8	30	28	25.5	20	14	8	-	-	-	-	-	-	
LKJ-801S	800	1.1	39	34.5	29	23	16.5	9.5	-	-	-	-	-	-	
LKJ-901S	900	1.2	43	39	34	28	21	12.5	3	-	-	-	-	-	
LKJ-1101S	1100	1.5	46	43	39	35	30	24	17	8	-	-	-	-	
LKJ-1301S	1300	1.75	48	45	41	36.5	31.5	26.5	21	14	8	-	-	-	

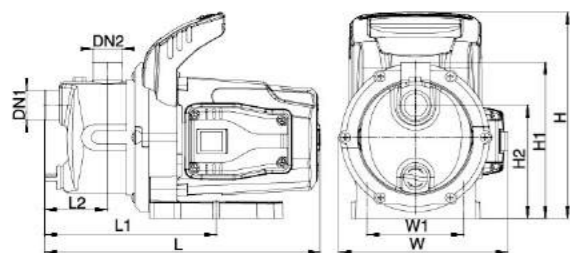

### Dimension

Model	DN1	DN2	L (mm)	W (mm)	H (mm)	L1 (mm)	L2 (mm)	W1 (mm)	H1 (mm)	H2 (mm)
LKJ-601S	1"	1"	342.5	210	255.5	221.5	78.5	120	193.5	140.5
LKJ-801S	1"	1"	342.5	210	255.5	221.5	78.5	120	193.5	140.5
LKJ-901S	1"	1"	369.5	243.5	284	233.5	87.5	120	215	165
LKJ-1101S	1"	1"	369.5	243.5	284	233.5	87.5	120	215	165
LKJ-1301S	1"	1"	369.5	243.5	284	233.5	87.5	120	215	165

### Hydraulic Performance Curves

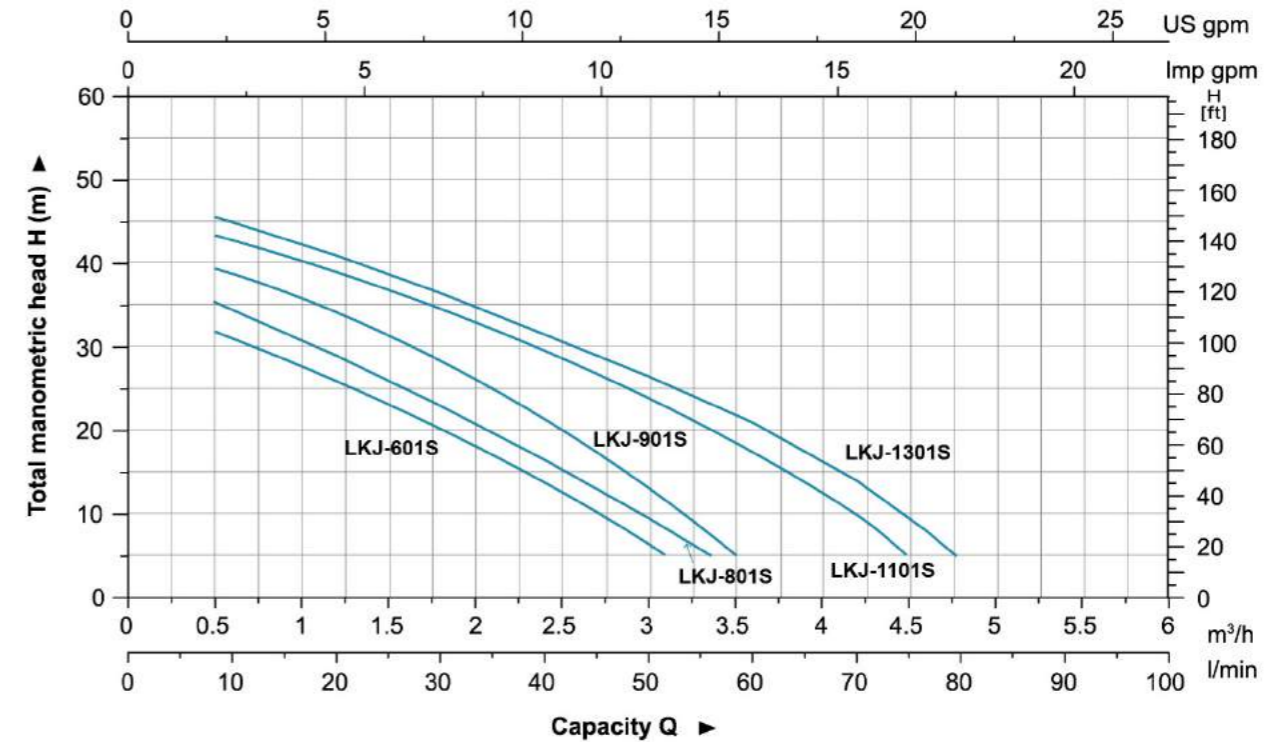

### Materials Table

No.	Part	Material
1	Drain plug	PP
2	Pump body	AISI 304
3	Holder	PP
4	Enjector	PPO
5	Diffuser	PPO
6	Impeller	PPO
7	O-ring	NBR
8	Mechanical seal	Carbon/Ceramic
9	Bracket cover	AISI 304
10	Terminal board	ABS
11	Capacitor	
12	Switch cover	ABS
13	Rotor	
14	Motor flange	PP
15	Front plate	ZL102
16	Stator	
17	Rear cover	ZL102
18	Handle	PP
19	Fan	PP
20	Fan cover	ABS

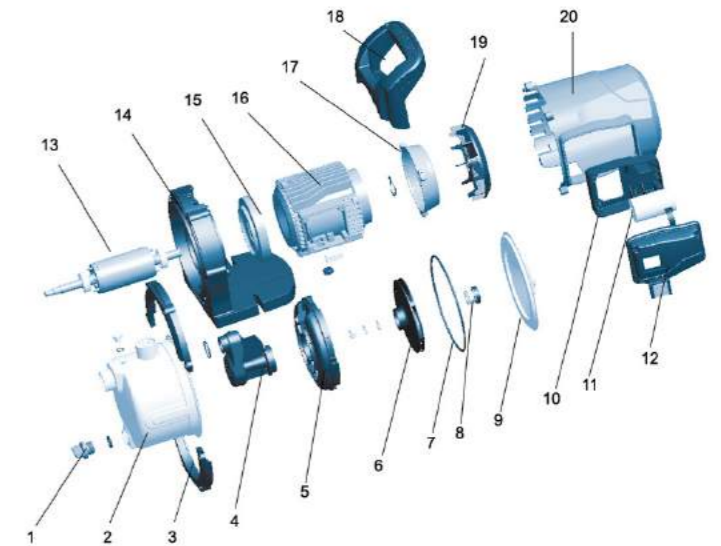

### Package Information

Model	GW (Kgs)	L (mm)	W (mm)	H (mm)	Quantity		
					20'/pcs	40'/pcs	40H'/pcs
LKJ-601S	6.9	375	230	280	1232	2512	2826
LKJ-801S	7.7	375	230	280	1232	2512	2826
LKJ-901S	9.2	395	260	320	868	1778	2032
LKJ-1101S	10.2	395	260	320	868	1778	2032
LKJ-1301S	10.6	395	260	320	868	1778	2032







### Application

- Can be used to transfer clean water or other liquids similar to water in physical and chemical properties
- Fully automatic water supply in house and garden

### Pump

- Unique ergonomic design
- Max. fluid temperature: +35°C
- Max. suction: +8 m

### Motor

- C&U bearing
- Built-in thermal protector
- Aluminum winding
- Insulation class: F
- Protection class: IPX4
- Max. ambient temperature: +40°C

### Identification Codes

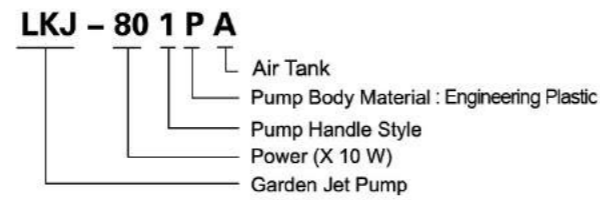

### Technical Data

MODEL	POWER (P <sub>2</sub> )		Q (m <sup>3</sup> /h)	H (m)											
	W	HP		Q (l/min)	0	0.6	1.2	1.8	2.4	3	3.6	4.2	4.8	5.4	6
LKJ-601PA	600	0.8	30	28	25.5	20	14	8	-	-	-	-	-	-	-
LKJ-801PA	800	1.1	39	34.5	29	23	16.5	9.5	-	-	-	-	-	-	-
LKJ-901PA	900	1.2	43	39	34	28	21	12.5	3	-	-	-	-	-	-
LKJ-1101PA	1100	1.5	46	43	39	35	30	24	17	8	-	-	-	-	-
LKJ-1301PA	1300	1.75	48	45	41	36.5	31.5	26.5	21	14	8	-	-	-	-

### Hydraulic Performance Curves

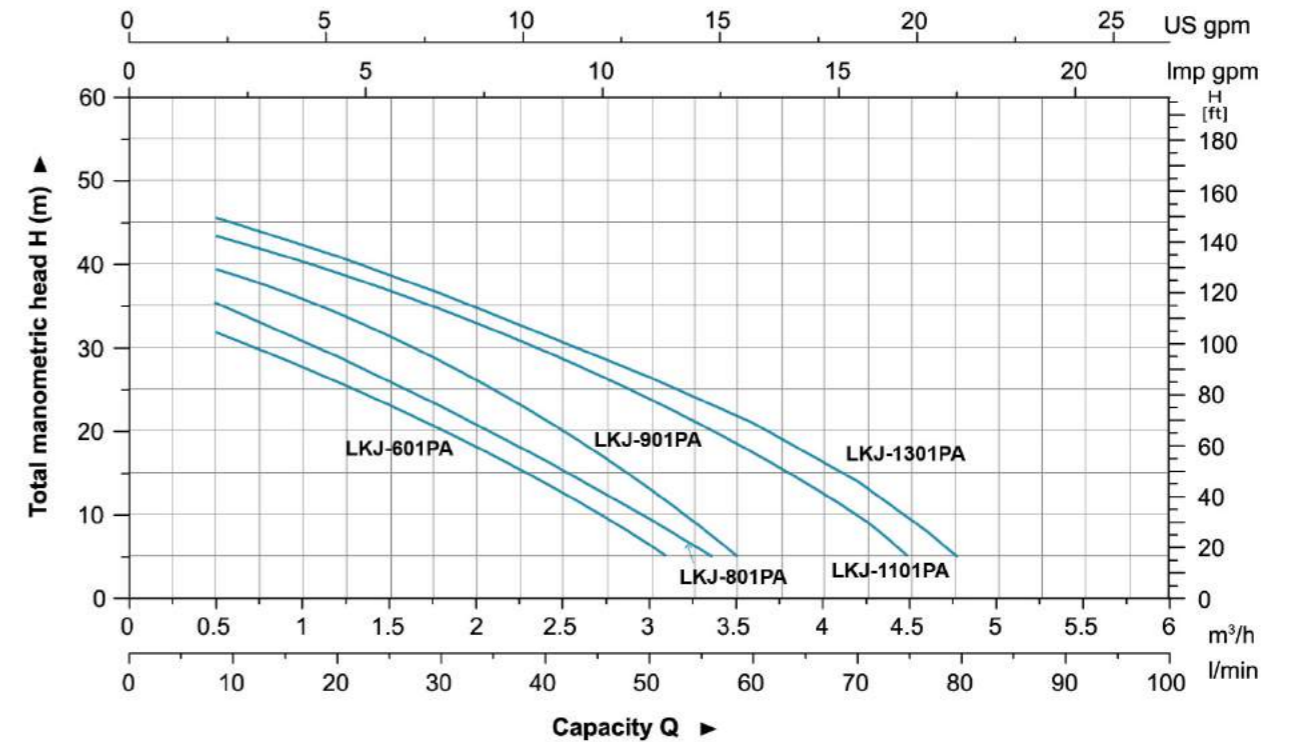

### Materials Table

No.	Part	Material	No.	Part	Material
1	Pressure switch		14	Mechanical seal	Carbon/Ceramic
2	Pressure gauge		15	Bracket cover	AISI 304
3	Tank cover	PA6	16	Terminal board	ABS
4	Drain plug	PP	17	Switch cover	ABS
5	Tank	08F	18	Capacitor	
6	Flexible hose		19	Plug	PP
7	Seal washer	NBR	20	Rotor	
8	Elbow connector	ABS	21	Motor flange	PP
9	Pump body	PP	22	Front plate	ZL102
10	Injector	PPO	23	Stator	
11	Diffuser	PPO	24	Rear cover	ZL102
12	Impeller	PPO	25	Fan	PP
13	O-ring	NBR	26	Motor cover	ABS

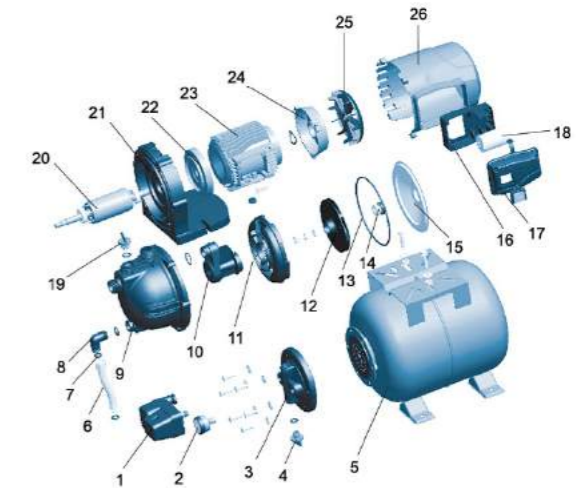

### Package Information

Model	GW (Kgs)	L (mm)	W (mm)	H (mm)	Quantity		
					20'/pcs	40'/pcs	40H'/pcs
LKJ-601PA	13.2	565	303	540	260	524	524
LKJ-801PA	14.1	565	303	540	260	524	524
LKJ-901PA	15.1	565	303	555	252	509	509
LKJ-1101PA	16.1	565	303	555	252	509	509
LKJ-1301PA	16.4	565	303	555	252	509	509

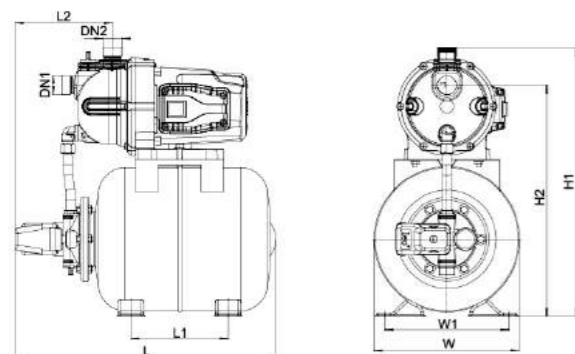

### Dimension

Model	DN1	DN2	L (mm)	W (mm)	L1 (mm)	L2 (mm)	W1 (mm)	H1 (mm)	H2 (mm)
LKJ-601PA	1"	1"	488	275	183	186	233	506	435.5
LKJ-801PA			488	275	183	186	233	506	435.5
LKJ-901PA			488	275	183	186	233	526.5	460
LKJ-1101PA			488	275	183	186	233	526.5	460
LKJ-1301PA			488	275	183	186	233	526.5	460





### Application

- Can be used to transfer clean water or other liquids similar to water in physical and chemical properties
- Fully automatic water supply in house and garden

### Pump

- Unique ergonomic design
- Max. fluid temperature: +35°C
- Max. suction: +8 m

### Motor

- C&U bearing
- Built-in thermal protector
- Aluminum winding
- Insulation class: F
- Protection class: IPX4
- Max. ambient temperature: +40°C

### Identification Codes

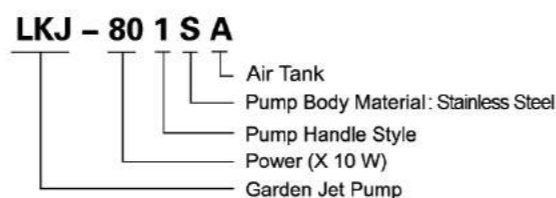

### Technical Data

MODEL	POWER (P <sub>2</sub> )		Q (m <sup>3</sup> /h)																																																																																			
	W	HP	0	0.6	1.2	1.8	2.4	3	3.6	4.2	4.8	5.4	6	0	10	20	30	40	50	60	70	80	90	100																																																														
LKJ-601SA	600	0.8	<div style="display: flex; align-items: center; justify-content: center;"> <div style="writing-mode: vertical-rl; transform: rotate(180deg); margin-right: 5px;">H (m)</div> <table border="1" style="border-collapse: collapse;"> <tr><td>30</td><td>28</td><td>25.5</td><td>20</td><td>14</td><td>8</td><td>-</td><td>-</td><td>-</td><td>-</td><td>-</td><td>-</td><td>-</td><td>-</td></tr> <tr><td>39</td><td>34.5</td><td>29</td><td>23</td><td>16.5</td><td>9.5</td><td>-</td><td>-</td><td>-</td><td>-</td><td>-</td><td>-</td><td>-</td><td>-</td></tr> <tr><td>43</td><td>39</td><td>34</td><td>28</td><td>21</td><td>12.5</td><td>3</td><td>-</td><td>-</td><td>-</td><td>-</td><td>-</td><td>-</td><td>-</td></tr> <tr><td>46</td><td>43</td><td>39</td><td>35</td><td>30</td><td>24</td><td>17</td><td>8</td><td>-</td><td>-</td><td>-</td><td>-</td><td>-</td><td>-</td></tr> <tr><td>48</td><td>45</td><td>41</td><td>36.5</td><td>31.5</td><td>26.5</td><td>21</td><td>14</td><td>8</td><td>-</td><td>-</td><td>-</td><td>-</td><td>-</td></tr> </table> </div>														30	28	25.5	20	14	8	-	-	-	-	-	-	-	-	39	34.5	29	23	16.5	9.5	-	-	-	-	-	-	-	-	43	39	34	28	21	12.5	3	-	-	-	-	-	-	-	46	43	39	35	30	24	17	8	-	-	-	-	-	-	48	45	41	36.5	31.5	26.5	21	14	8	-	-	-	-	-
30	28	25.5															20	14	8	-	-	-	-	-	-	-	-																																																											
39	34.5	29															23	16.5	9.5	-	-	-	-	-	-	-	-																																																											
43	39	34															28	21	12.5	3	-	-	-	-	-	-	-																																																											
46	43	39															35	30	24	17	8	-	-	-	-	-	-																																																											
48	45	41	36.5	31.5	26.5	21	14	8	-	-	-	-	-																																																																									
LKJ-801SA	800	1.1																																																																																				
LKJ-901SA	900	1.2																																																																																				
LKJ-1101SA	1100	1.5																																																																																				
LKJ-1301SA	1300	1.75																																																																																				

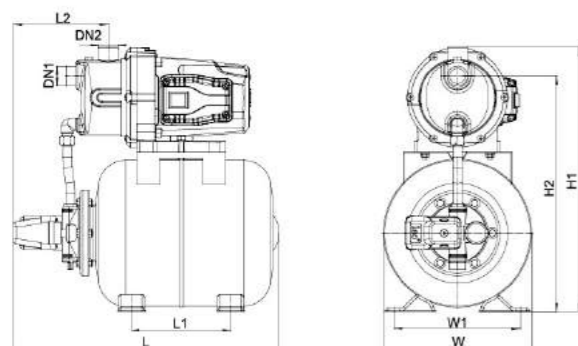

### Dimension

Model	DN1	DN2	L (mm)	W (mm)	L1 (mm)	L2 (mm)	W1 (mm)	H1 (mm)	H2 (mm)
LKJ-601SA	1"	1"	488	275	183	178	233	488.5	435.5
LKJ-801SA			488	275	183	178	233	488.5	435.5
LKJ-901SA			488	275	183	178	233	510	460
LKJ-1101SA			488	275	183	178	233	510	460
LKJ-1301SA			488	275	183	178	233	510	460

### Hydraulic Performance Curves

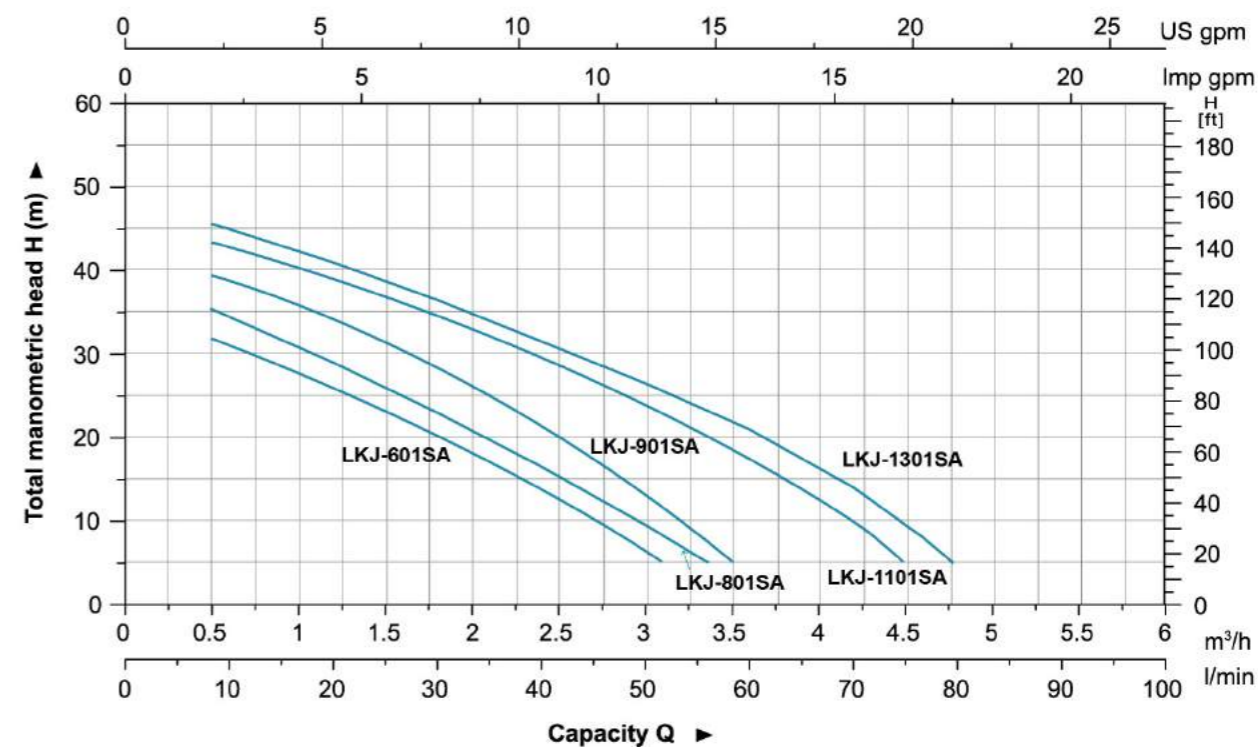

### Materials Table

No.	Part	Material	No.	Part	Material
1	Pressure switch		15	Mechanical seal	Carbon/Ceramic
2	Pressure gauge		16	Bracket cover	AISI 304
3	Tank cover	PA6	17	Terminal board	ABS
4	Drain plug	PP	18	Switch cover	ABS
5	Tank	08F	19	Capacitor	
6	Flexible hose		20	Plug	PP
7	Seal washer	NBR	21	Rotor	
8	Elbow connector	ABS	22	Motor flange	PP
9	Pump body	AISI 304	23	Front plate	ZL102
10	Frisket	PP	24	Stator	
11	Enjector	PPO	25	Rear cover	ZL102
12	Diffuser	PPO	26	Fan	PP
13	Impeller	PPO	27	Motor cover	ABS
14	O-ring	NBR			

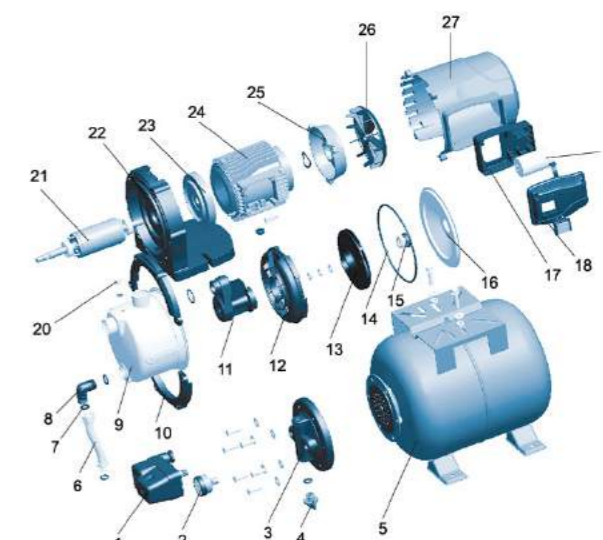

### Package Information

Model	GW (Kgs)	L (mm)	W (mm)	H (mm)	Quantity		
					20'/pcs	40'/pcs	40H'/pcs
LKJ-601SA	13.4	565	303	540	260	524	524
LKJ-801SA	14.3	565	303	540	260	524	524
LKJ-901SA	15.3	565	303	555	252	509	509
LKJ-1101SA	16.3	565	303	555	252	509	509
LKJ-1301SA	16.6	565	303	555	252	509	509







### Application

- Filter of the pond water
- Beautiful ornament for the pond
- Oxygen enrichment of the pond water

### Features

- Plastic casing
- Small, lightweight, durable and reliable
- Various nozzles available for displaying of cascade, water bell, etc.

### Identification Codes

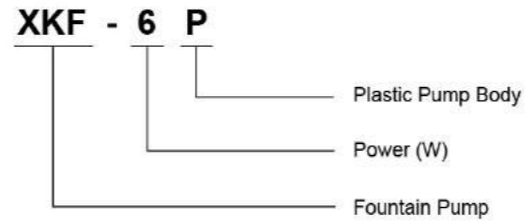

### Technical Data

Model	Voltage	Input Power (W)	Max.Head (m)	Max.Flow (L/h)	Outlet (mm)	Cable
XKF-6P	220V-240V/50Hz	6	0.7	380	13	H05RN-F 10m
XKF-15P	220V-240V/50Hz	15	1.0	850	13	H05RN-F 10m
XKF-20P	220V-240V/50Hz	20	1.1	1100	13	H05RN-F 10m

**Operating Limits:** Fluid temperature up to 35°C; Ambient temperature up to 40°C.

### Application

- Filter of the pond water
- Beautiful ornament for the pond
- Oxygen enrichment of the pond water

### Features

- Plastic casing
- Small, lightweight, durable and reliable
- Various nozzles available for displaying of cascade, water bell, etc.

### Identification Codes

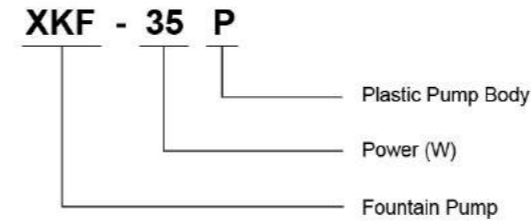

### Technical Data

Model	Voltage	Input Power (W)	Max.Head (m)	Max.Flow (L/h)	Outlet (mm)	Cable
XKF-35P	220V-240V/50Hz	35	1.4	1600	19	H05RN-F 10m
XKF-55P	220V-240V/50Hz	55	2.3	2300	19	H05RN-F 10m
XKF-75P	220V-240V/50Hz	75	2.7	2650	19	H05RN-F 10m
XKF-95P	220V-240V/50Hz	95	3.0	3500	19	H05RN-F 10m
XKF-110P	220V-240V/50Hz	110	3.7	3750	19	H05RN-F 10m

**Operating Limits:** Fluid temperature up to 35°C; Ambient temperature up to 40°C.

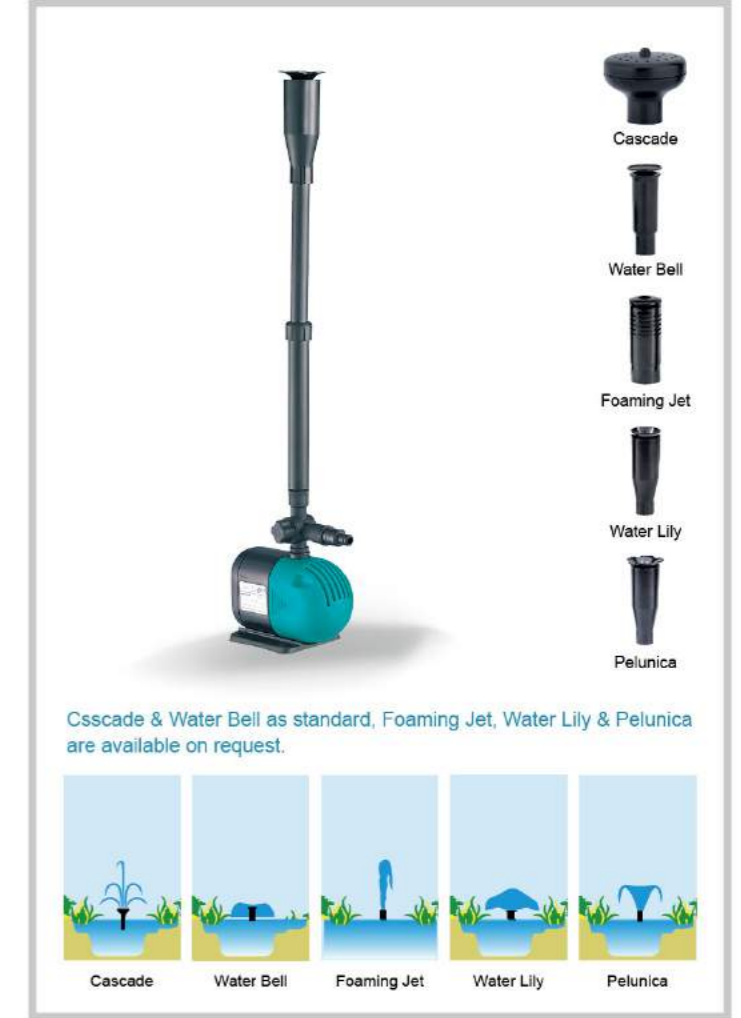

Cascade & Water Bell as standard, Foaming Jet, Water Lily & Pelunica are available on request.

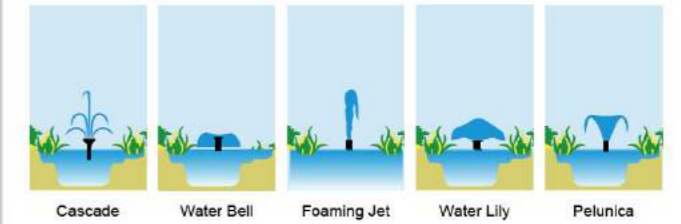





0.75kw~7.5kw



9.2kw~55kw

### Application

- Circulation and transfer of clean, chemically non-aggressive water and other liquids
- Water supply & irrigation
- Water circulation in air conditioning systems

### Operating conditions

- Delivery: up to 220 m<sup>3</sup>/h
- Head: up to 95 m
- Liquid temperature:
- Standard: -10°C to 85°C
- Maximum operating pressure: 12 bar (PN12)
- Anti-clockwise rotation when facing pump's suction port
- Impeller: AISI304/HT200
- Mechanical seal in compliance with DIN 24960
- Lubricated by internal recirculating pumped liquid
- Counter flange available on request

### Motor

- Closed construction, external ventilation
- Insulation class: F
- Protection class: IP54
- Performance in compliance with CEI 2-3 (IEC 34.1)
- Max.ambient temperature: +40°C
- Overload protection
- For model that ≥9.2kw: Equipped with IE2 motor, IE3 motor available on request.

For model that ≤7.5kw, the following 4 models can equipped with IE3 motor.  
(XST40-160/30、XST40-160/40、XST50-160/55、XST50-160/75)

### Identification Codes

**XST m 32 – 125 K / 11**

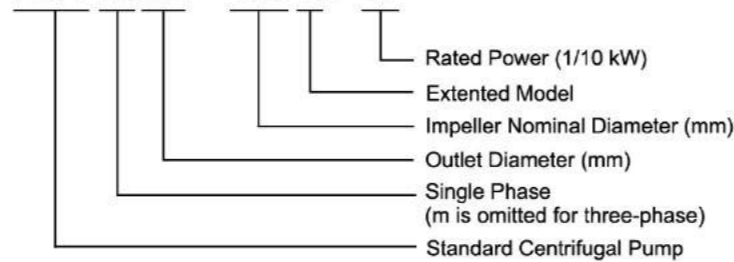

### Construction Features

- Single-impeller centrifugal pump featuring axial intake and radial discharge
- Inlet and outlet DN in compliance with EN 733 (ex DIN 24255) and UNI 7467
- Flanges in compliance with UNI 2236 and DIN 2532
- Rear entry (impeller, motor can be extracted without disconnecting the pump body from the pipes)

### Materials Table

0.75kw~7.5kw

No.	Part	Material
1	Flange	HT200
2	Pump body	HT200
3	Impeller	HT200 / AISI304
4	Mechanical seal	Carbon/Silicon carbide
5	O-ring	NBR
6	Pump support	HT200
7	Fan cover	08F
8	Fan	PP
9	Rear cover	ZL102
10	Support	HT200
11	Stator	
12	Bearing	
13	Rotor	
14	Bearing	
15	Oil seal	

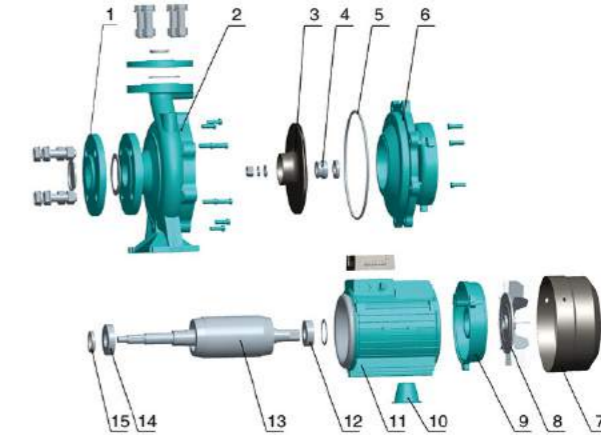

9.2kw~55kw

No.	Part	Material
1	Flange	HT200
2	Pump body	HT200
3	O-ring	NBR
4	Impeller	HT200 / AISI304
5	Mechanical seal	Carbon/Silicon carbide
6	Guarding plate	06Cr19Ni10
7	Pump support	HT200
8	Pump shaft	45/06Cr19Ni10
9	Motor	



### How to Read The Curve Charts

The thin curves indicate the duty range where long-time operation is not allowed

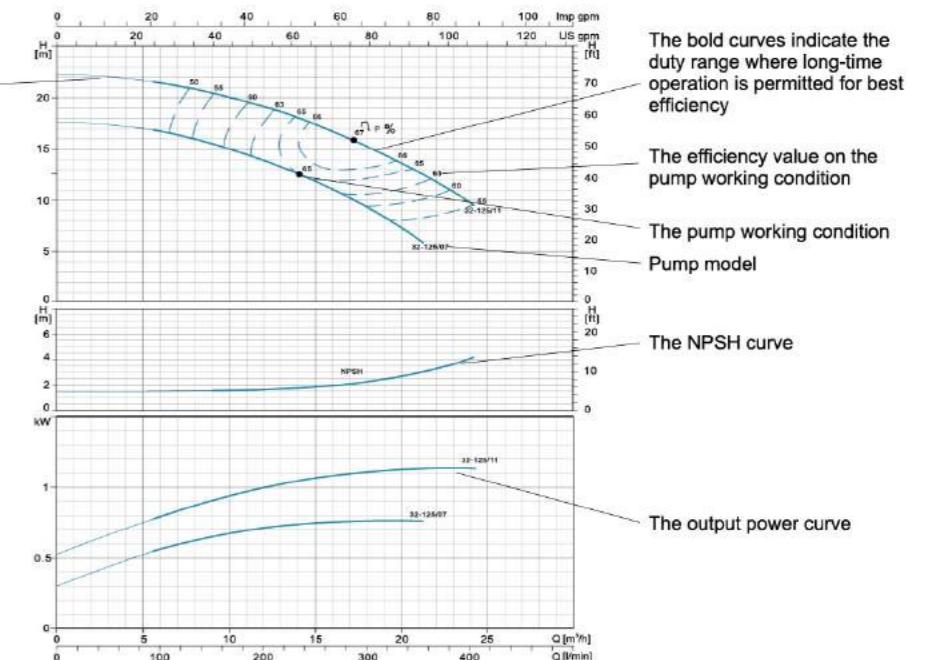

### Guidelines to Performance Curves

Tolerances to ISO 9906, Annex A. Measurements have been made with airless water at a temperature of 20°C and kinematic viscosity of 1 mm<sup>2</sup>/s. To avoid overheating of the motor, the pump should not be use against a high head for a long time.



Technical Data

PUMP TYPE	POWER		l/min m³/h	Q=DELIVERY																			
	kW	HP		0	100	150	250	300	400	450	600	700	800	900	1200	1400	1500	1800	2000	2300	3000	3500	
32-125/7*Δ	0.75	1	17.5	16.7	15	12	9																
32-125/11*Δ	1.1	1.5	22	21	20.2	17	15	9															
32-160/15*Δ	1.5	2	24	23.7	22.5	19.5	16.2																
32-160/22*Δ	2.2	3	31	29.6	29	25.5	22.5	15															
32-160/30*Δ	3	4	34.5	33.5	33	29	26.5	20	16.5														
32-200/30*	3	4	43.2	42	40.5	35.2	32.2	24.6	19.8														
32-200/40*	4	5.5	52	50.5	50	45	41.9	35	30.3														
32-250/55**	5.5	7.5	79	74.7	71.8	63	56	37.5															
32-250/75**	7.5	10	95	92	89	82	75	57.8															
40-125/11Δ	1.1	1.5	14.7				13	11.5	10.1														
40-125/15Δ	1.5	2	18.1				17	15	13.9														
40-125/22Δ	2.2	3	24.5				23.2	21.5	20.2	16	12												
40-160/30	3	4	31.8				29	27.5	26.3	21.5	17.5												
40-160/40	4	5.5	38				36	34	33	28.5	25	20.1											
40-200/55*	5.5	7.5	44				42	40	38	32	27												
40-200/75*	7.5	10	55				52	49	48	42	37	32											
40-250/92*	9.2	12.5	64				59	56.5	55	49.5	45	39.8											
40-250/110*	11	15	72				67.5	65	63.5	57.5	52.2	47											
40-250/150*	15	20	82				79	77.3	76.5	71	66	60.5											
50-125/22Δ	2.2	3	17							15.4	14	12.8	11.5										
50-125/30	3	4	20							18.8	18	17	15.6										
50-125/40	4	5.5	24							23.1	22.6	21.5	20.3	15.8									
50-160/55	5.5	7.5	32							30.6	30	28	26.6	20.5									
50-160/75	7.5	10	40							38	37	36	34.4	29									
50-200/92*	9.2	12.5	50.5							46.8	45	43	40.9	32.5									
50-200/110*	11	15	57.5							53.5	52	50	47.5	40									
50-250/150*	15	20	68.5							64	63	61.5	59	50	41								
50-250/185*	18.5	25	77							73.2	72	70	68	60.5	51.5								
50-250/220*	22	30	86.3							83	81.5	80	78	70	61								
65-125/40	4	5.5	19									17.3	16.8	14.5	13	11.8							
65-125/55	5.5	7.5	23									21.3	20.9	19	17.5	16.7	13.7						
65-125/75	7.5	10	27									26	25.6	24.5	23	22.5	20	18					
65-160/92	9.2	12.5	33										31.5	30	28	27.1	24	21.5					
65-160/110	11	15	36										34.5	33	31.5	30.8	28	25.5					
65-160/150	15	20	42										41	40	38.5	37.8	35	33					
65-200/150	15	20	45.5										46	43.5	41	39.2	33						
65-200/185	18.5	25	53										53.5	51.2	48.3	47	41.5						
65-200/220	22	30	59										59.5	57.2	54	53	47	43.5					
65-200K/185	18.5	25	41.2											42	41.2	40.6	38.2	36.5	34				
65-200K/220	22	30	48												48	47.5	46	44	41				
65-200K/300	30	40	59.5												59	58.5	58	56.2	54				
65-250/220	22	30	62												61.5	58.2	56.5	54	49	45			
65-250/300	30	40	76												75	73	70	69	64	61	54		
65-250/370	37	50	90												88	86	84	82	78	74	68		
80-160/110	11	15	27														27.3	26	24.5	22.5	16		
80-160/150	15	20	32.8														32.5	31.3	30.2	28	22.1	16.7	
80-160/185	18.5	25	39														38	36.8	35.7	33.8	28.8	23.5	
80-200/220	22	30	48														47.5	46	43.5	41	32.5		
80-200/300	30	40	60														59.5	58	57	54.5	47		
80-250/370	37	50	71.5														70.5	67.5	65.5	61.5	49.5	38	
80-250/450	45	60	82														80.5	78.5	76.5	72	62	51	
80-250/550	55	75	95														93.5	91.2	89.8	86.8	77.6	68.3	

\* =AISI304 impeller \*\* =Double AISI304 impeller  
Models marked with \* Δ \* have both single phase and three phase type, other models only have three phase type

Characteristic Curves

XST	~2900rpm	ISO 9906 Annex A
-----	----------	------------------

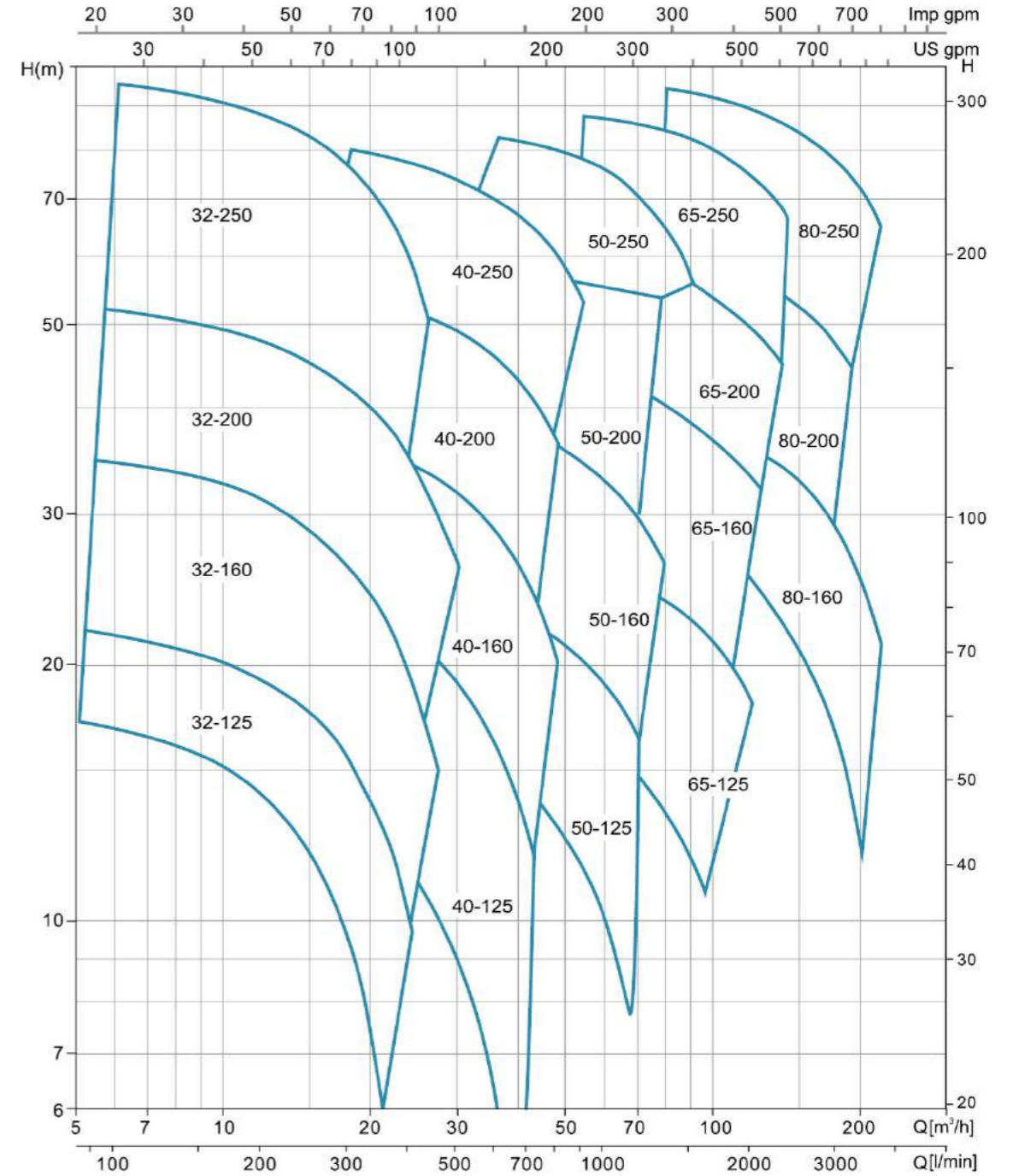



Hydraulic Performance Curves

XST(m)32-125	~2900rpm	ISO 9906 Annex A
--------------	----------	------------------

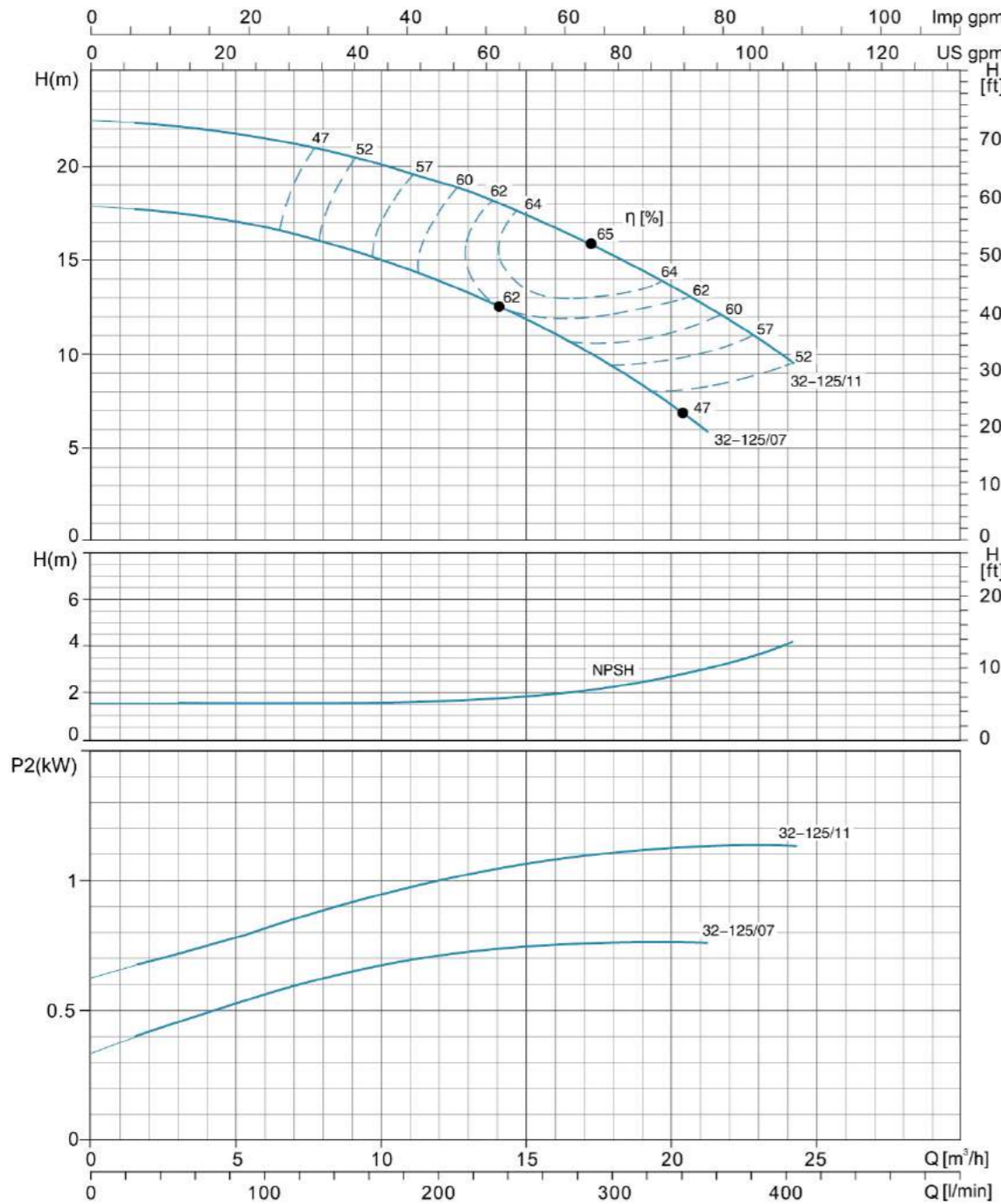

Hydraulic Performance Curves

XST(m)32-160	~2900rpm	ISO 9906 Annex A
--------------	----------	------------------

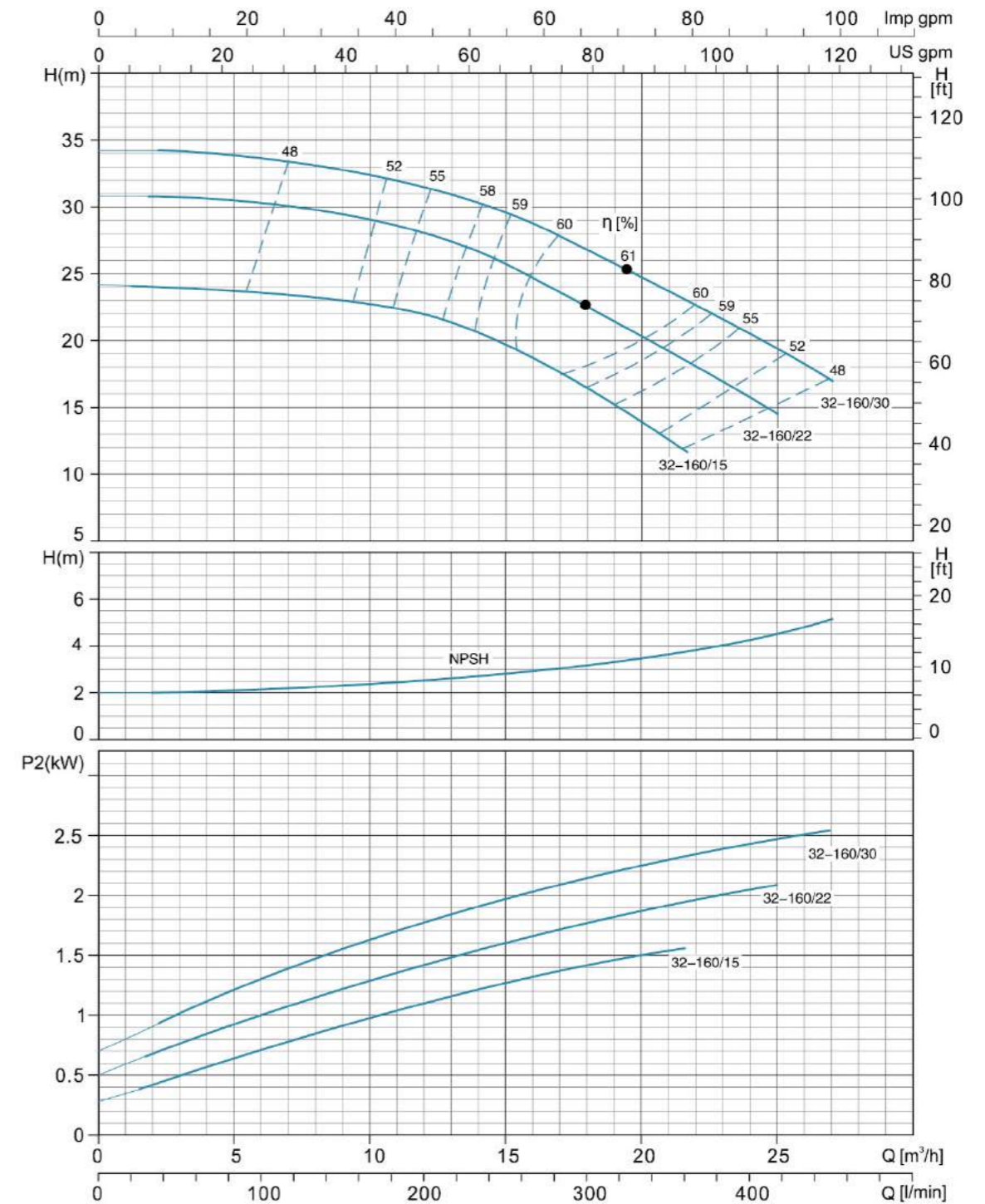



Hydraulic Performance Curves

XST32-200	~2900rpm	ISO 9906 Annex A
-----------	----------	------------------

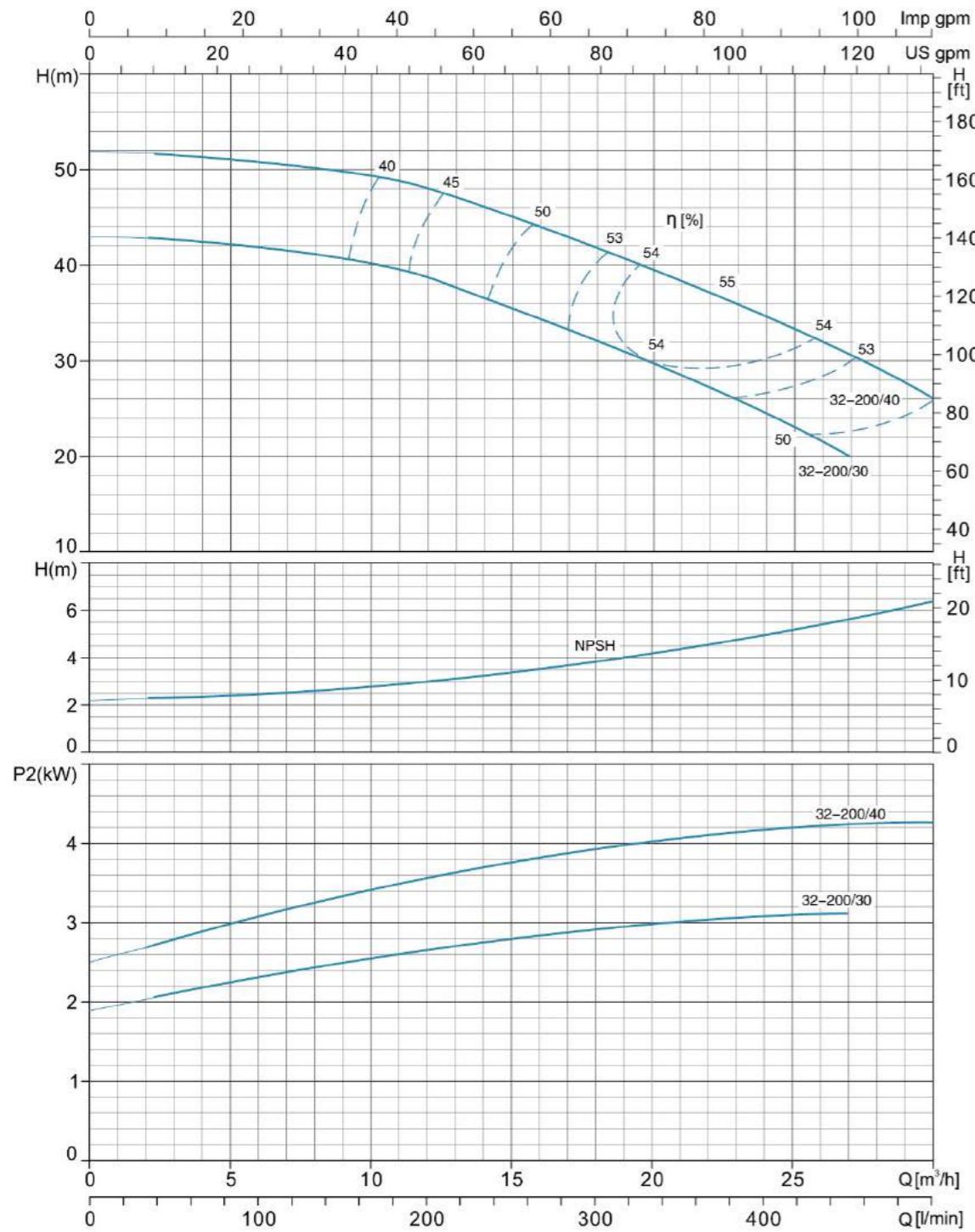

Hydraulic Performance Curves

XST32-250	~2900rpm	ISO 9906 Annex A
-----------	----------	------------------

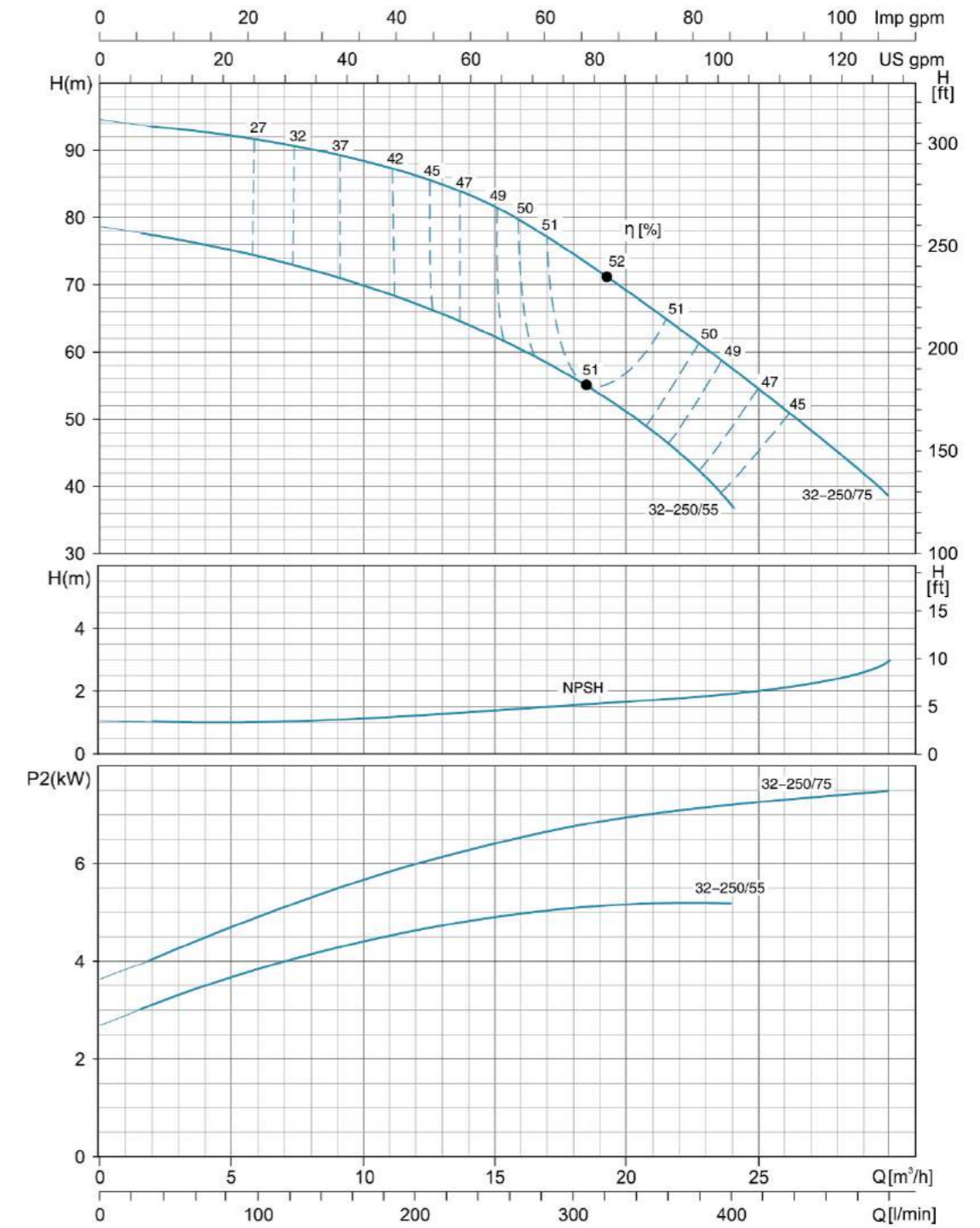



Hydraulic Performance Curves

XST(m)40-125	~2900rpm	ISO 9906 Annex A
--------------	----------	------------------

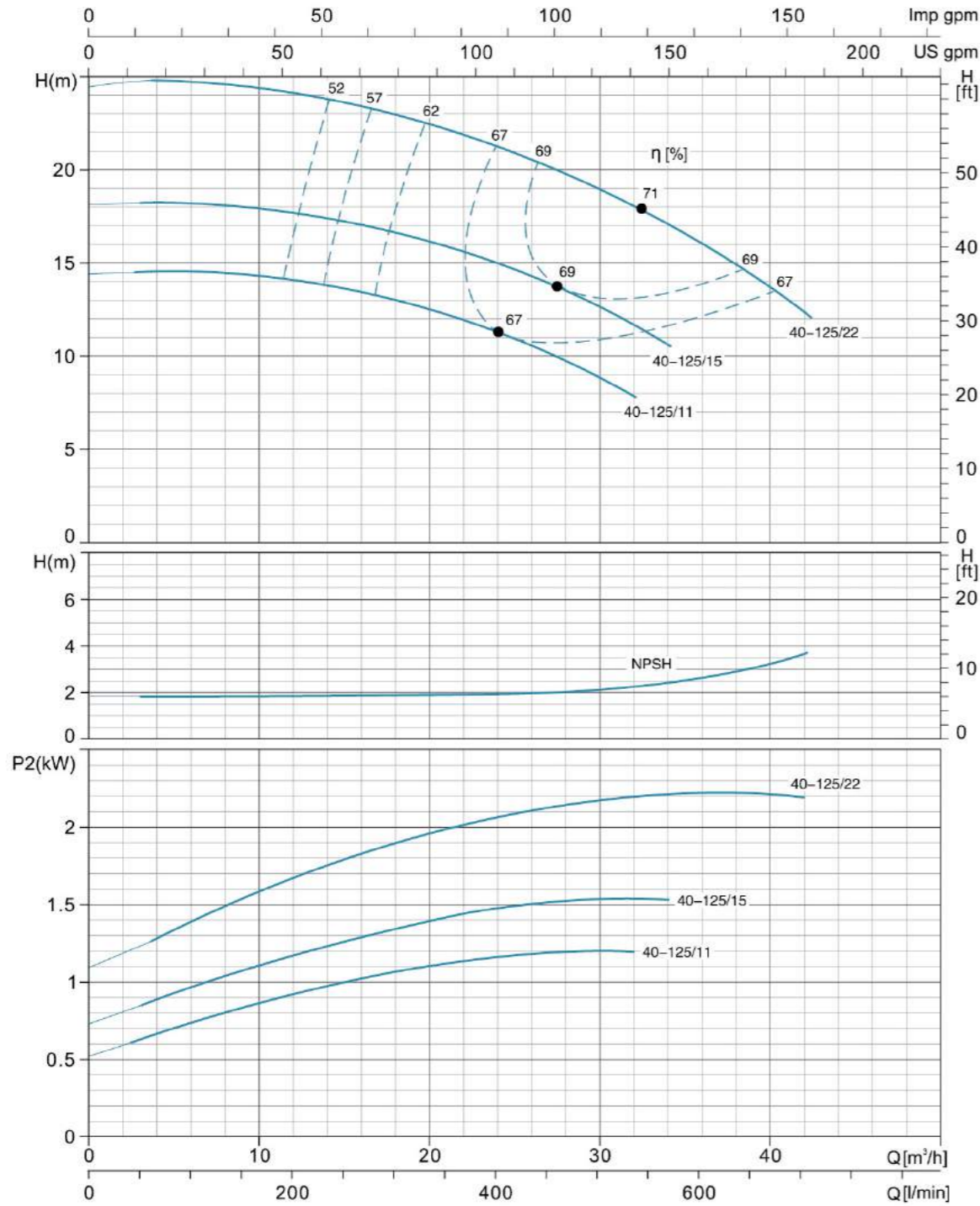

Hydraulic Performance Curves

XST40-160	~2900rpm	ISO 9906 Annex A
-----------	----------	------------------

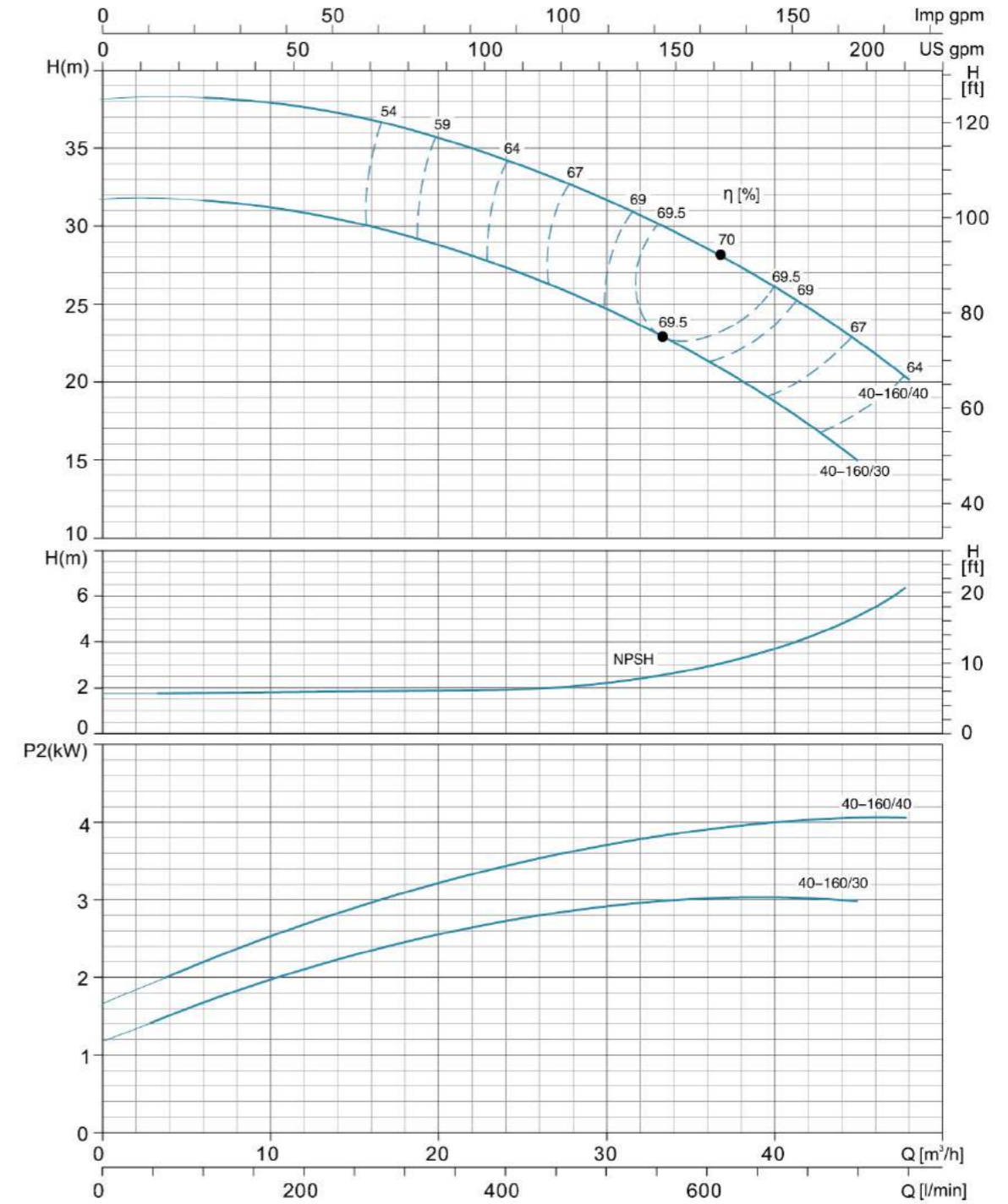



Hydraulic Performance Curves

XST40-200	~2900rpm	ISO 9906 Annex A
-----------	----------	------------------

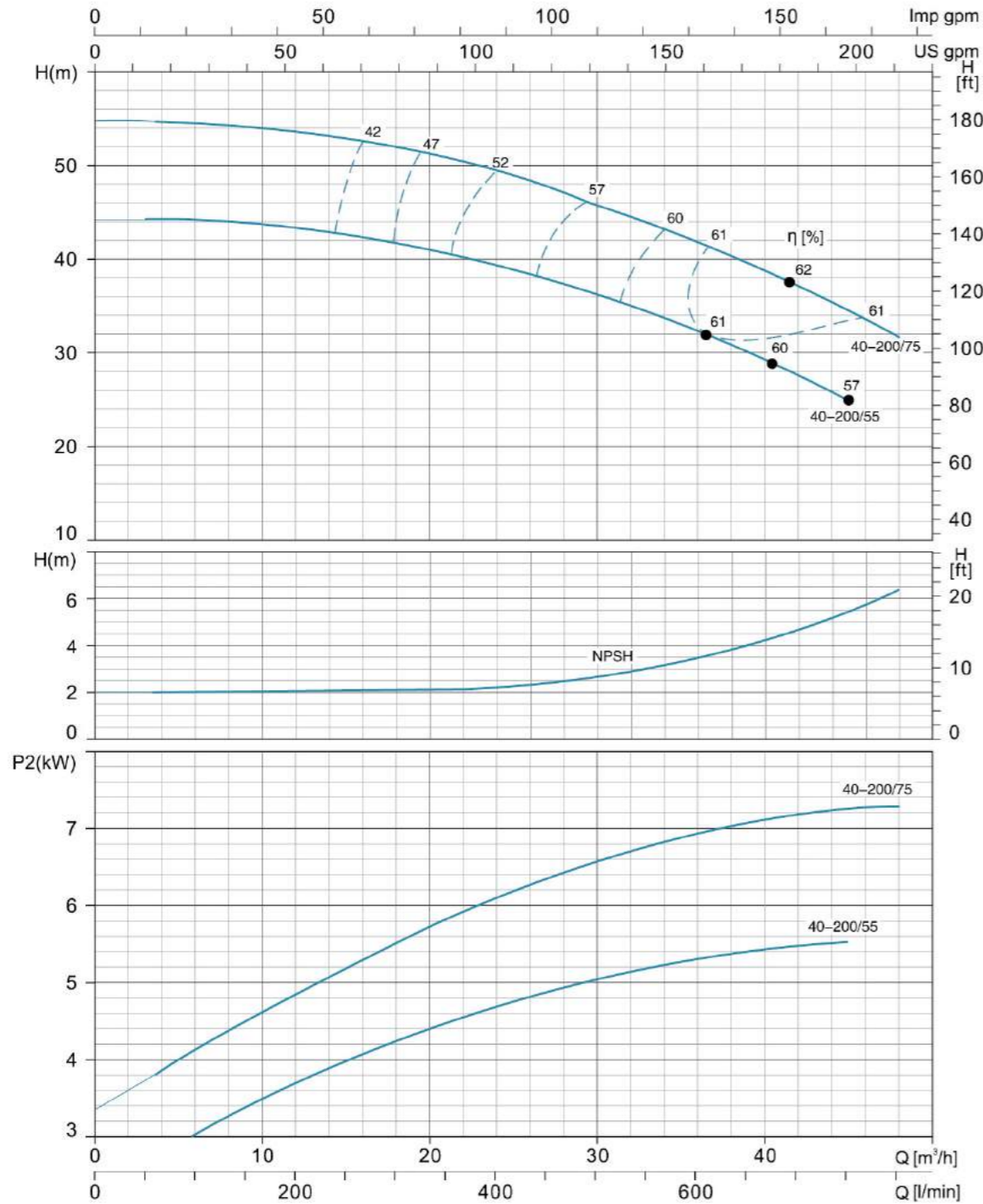

Hydraulic Performance Curves

XST40-250	~2900rpm	ISO 9906 Annex A
-----------	----------	------------------

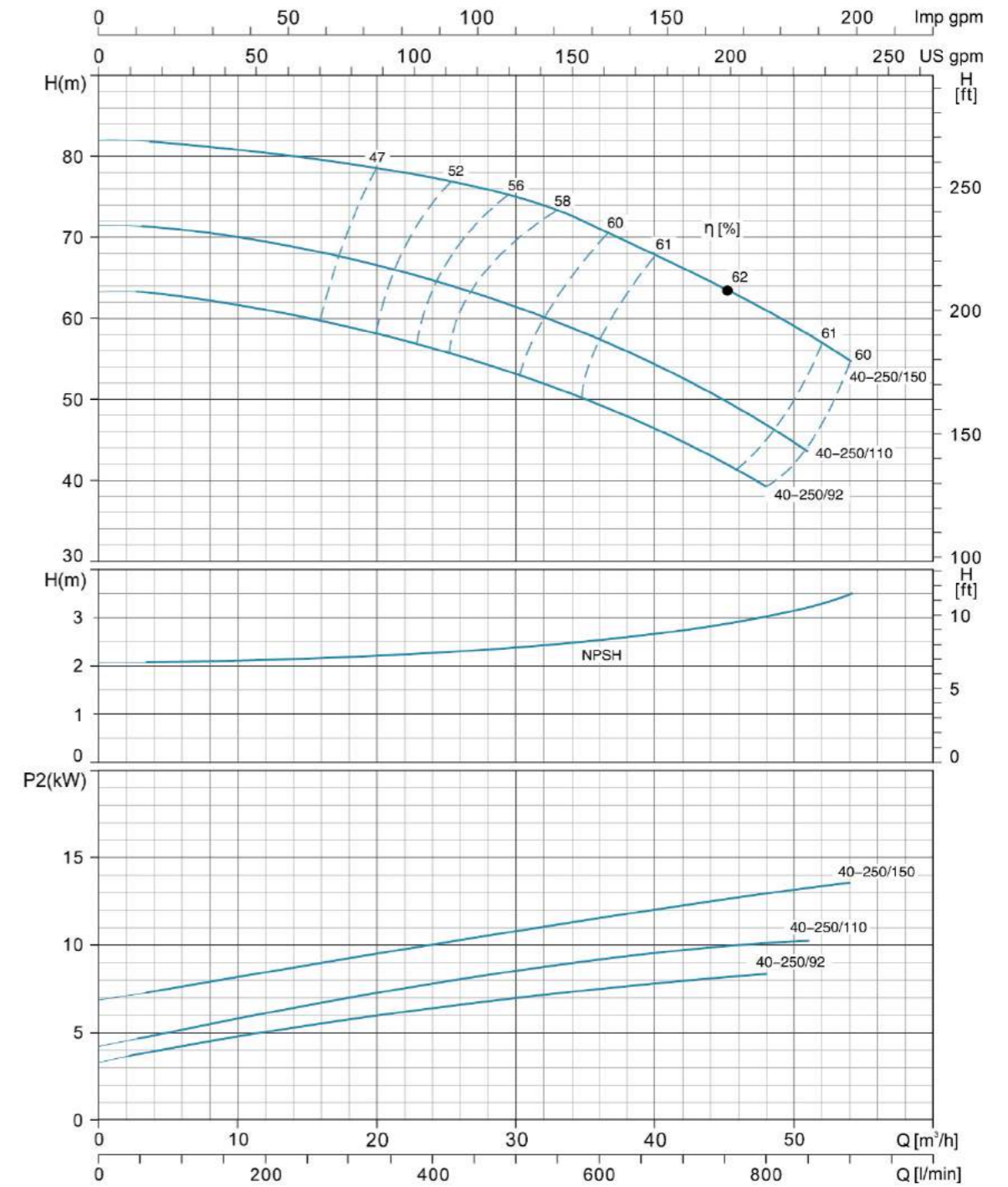



Hydraulic Performance Curves

XST(m)50-125	~2900rpm	ISO 9906 Annex A
--------------	----------	------------------

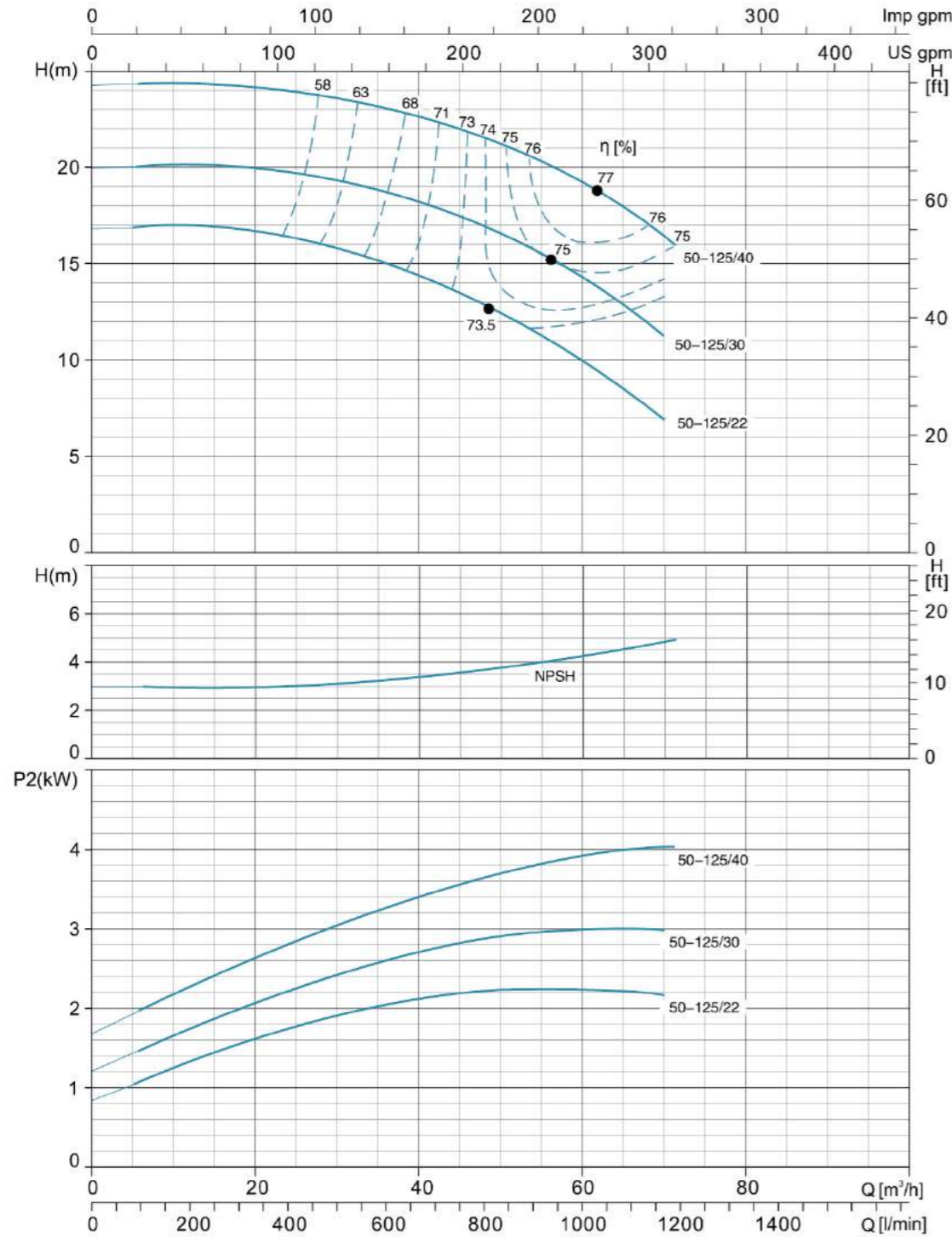

Hydraulic Performance Curves

XST50-160	~2900rpm	ISO 9906 Annex A
-----------	----------	------------------

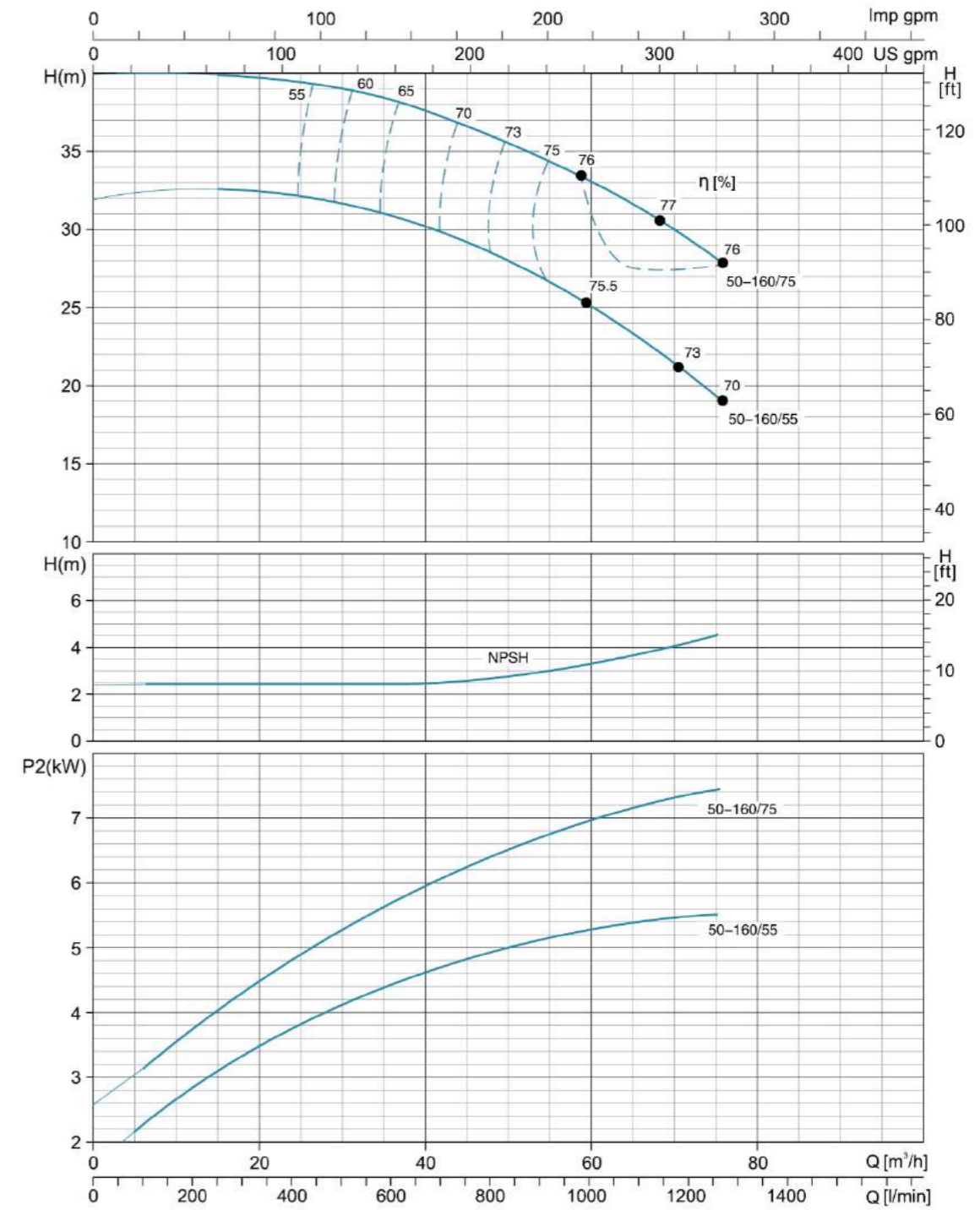



Hydraulic Performance Curves

XST50-200	~2900rpm	ISO 9906 Annex A
-----------	----------	------------------

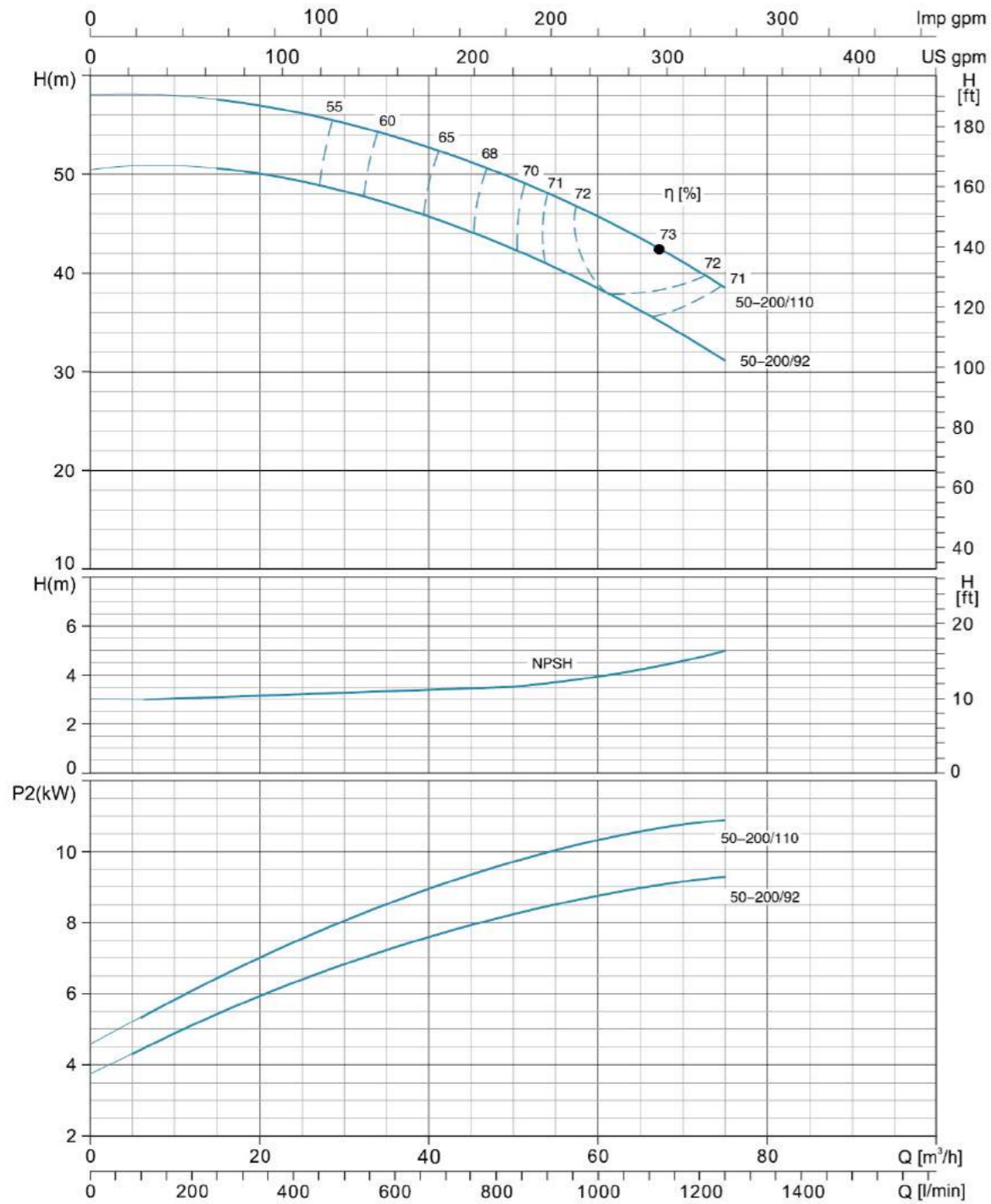

Hydraulic Performance Curves

XST50-250	~2900rpm	ISO 9906 Annex A
-----------	----------	------------------

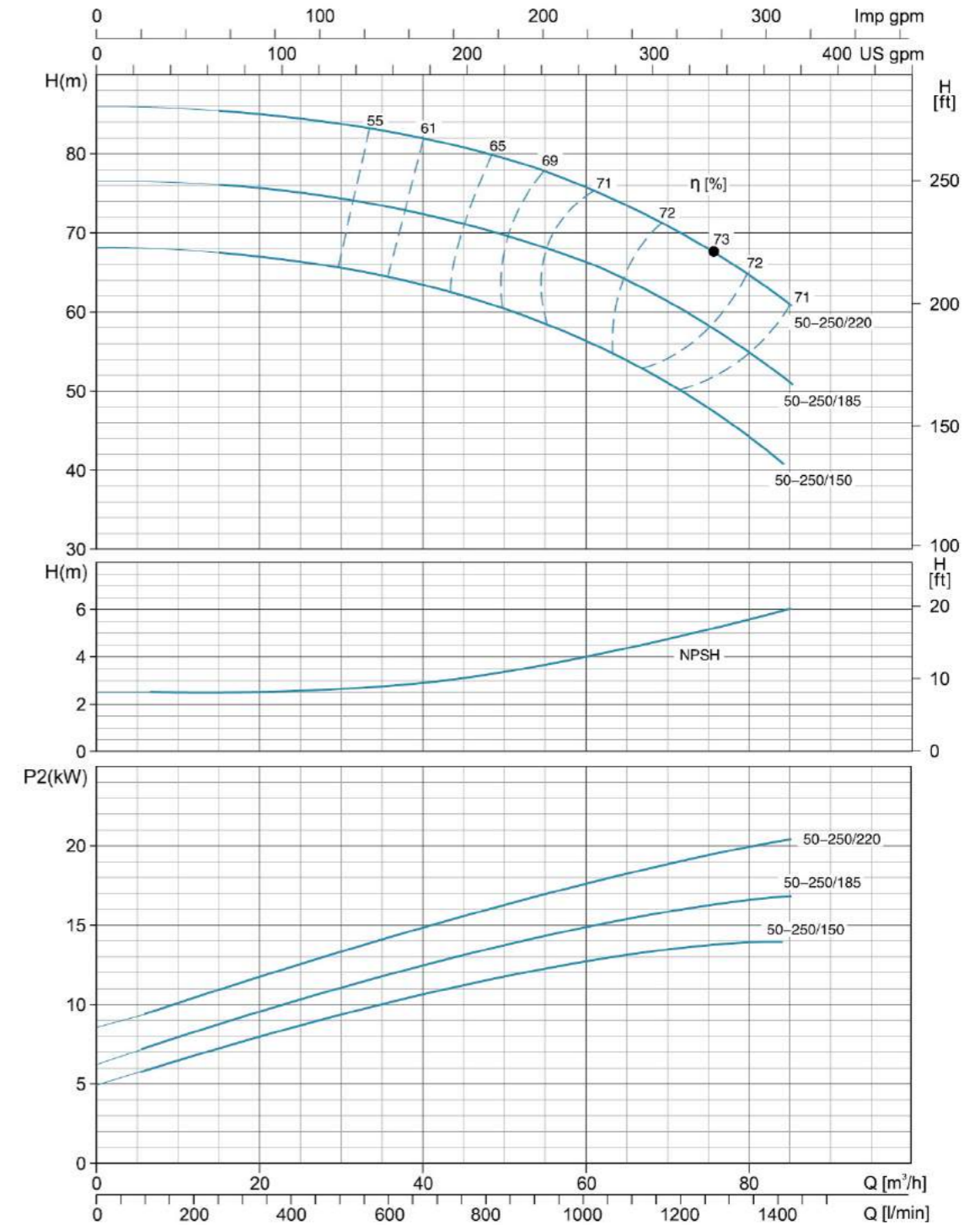



Hydraulic Performance Curves

XST65-125	~2900rpm	ISO 9906 Annex A
-----------	----------	------------------

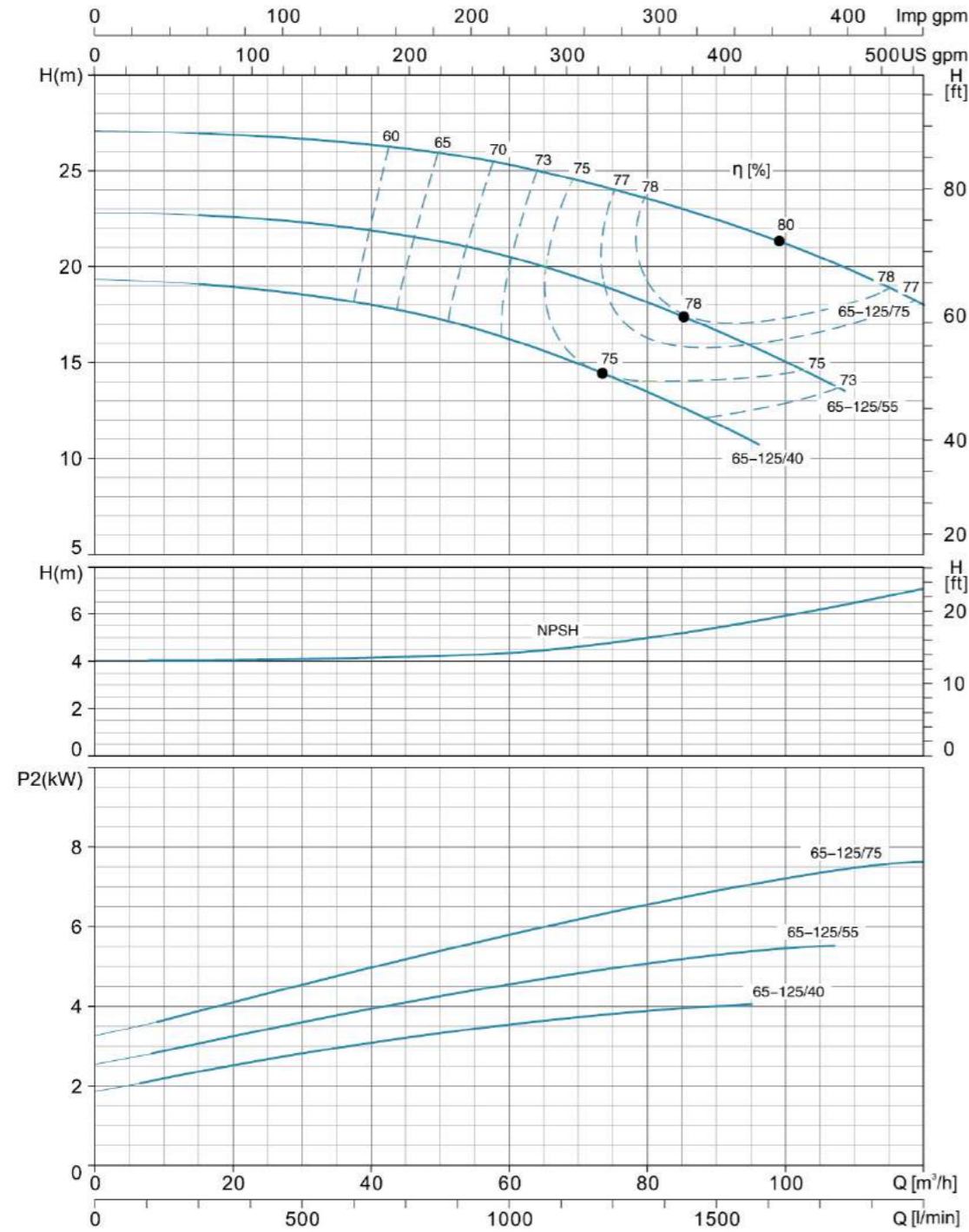

Hydraulic Performance Curves

XST65-160	~2900rpm	ISO 9906 Annex A
-----------	----------	------------------

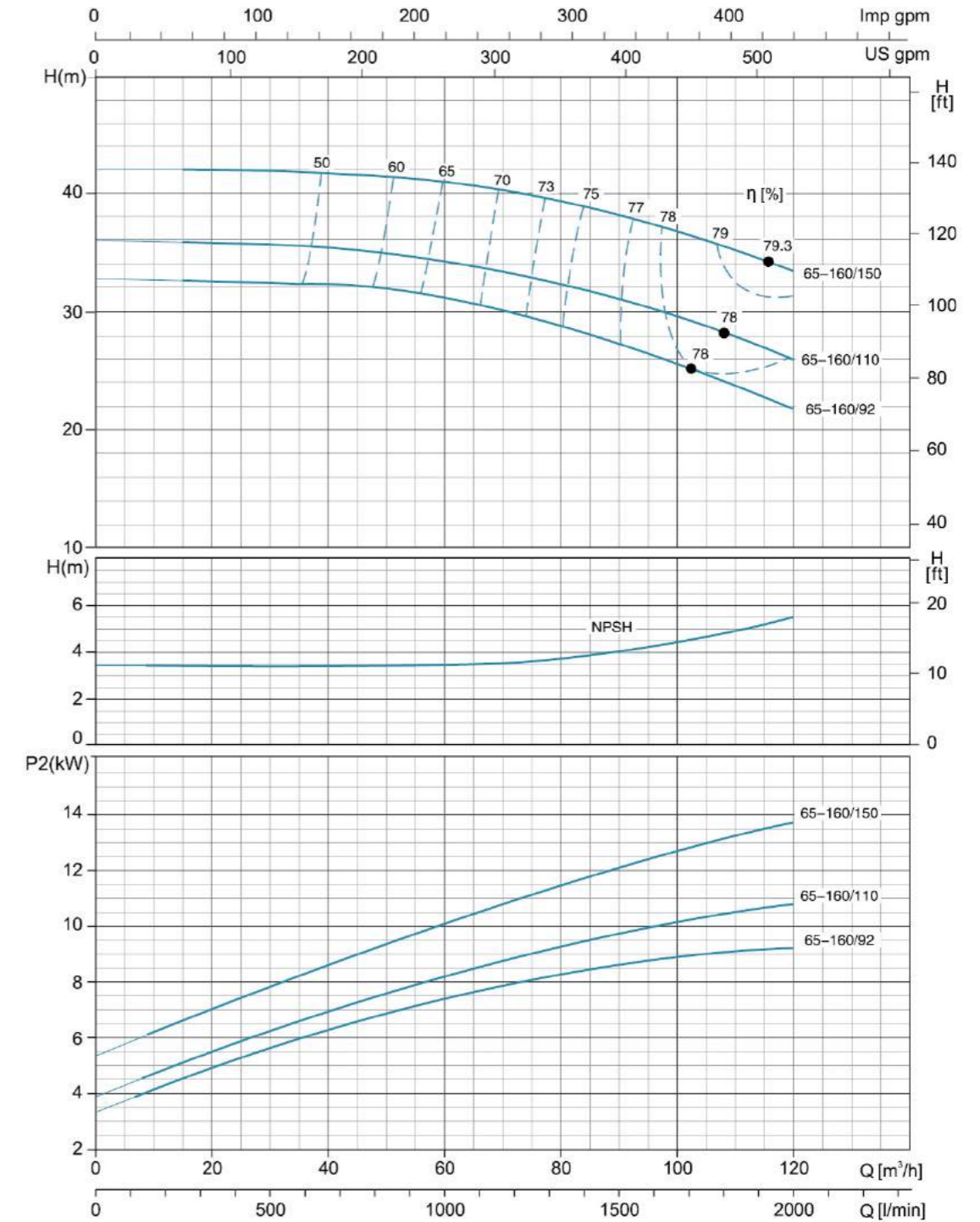



Hydraulic Performance Curves

XST65-200	~2900rpm	ISO 9906 Annex A
-----------	----------	------------------

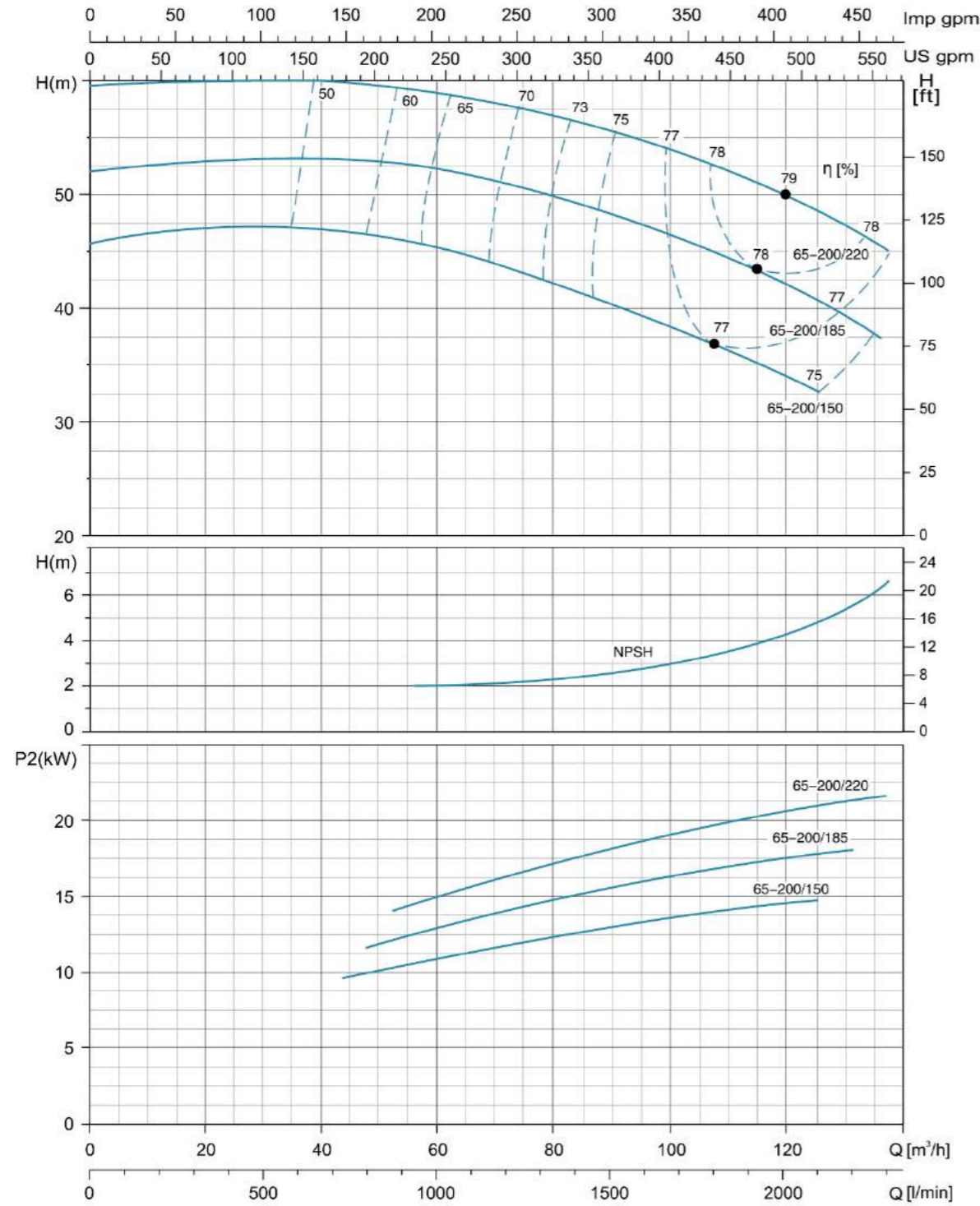

Hydraulic Performance Curves

XST65-200K	~2900rpm	ISO 9906 Annex A
------------	----------	------------------

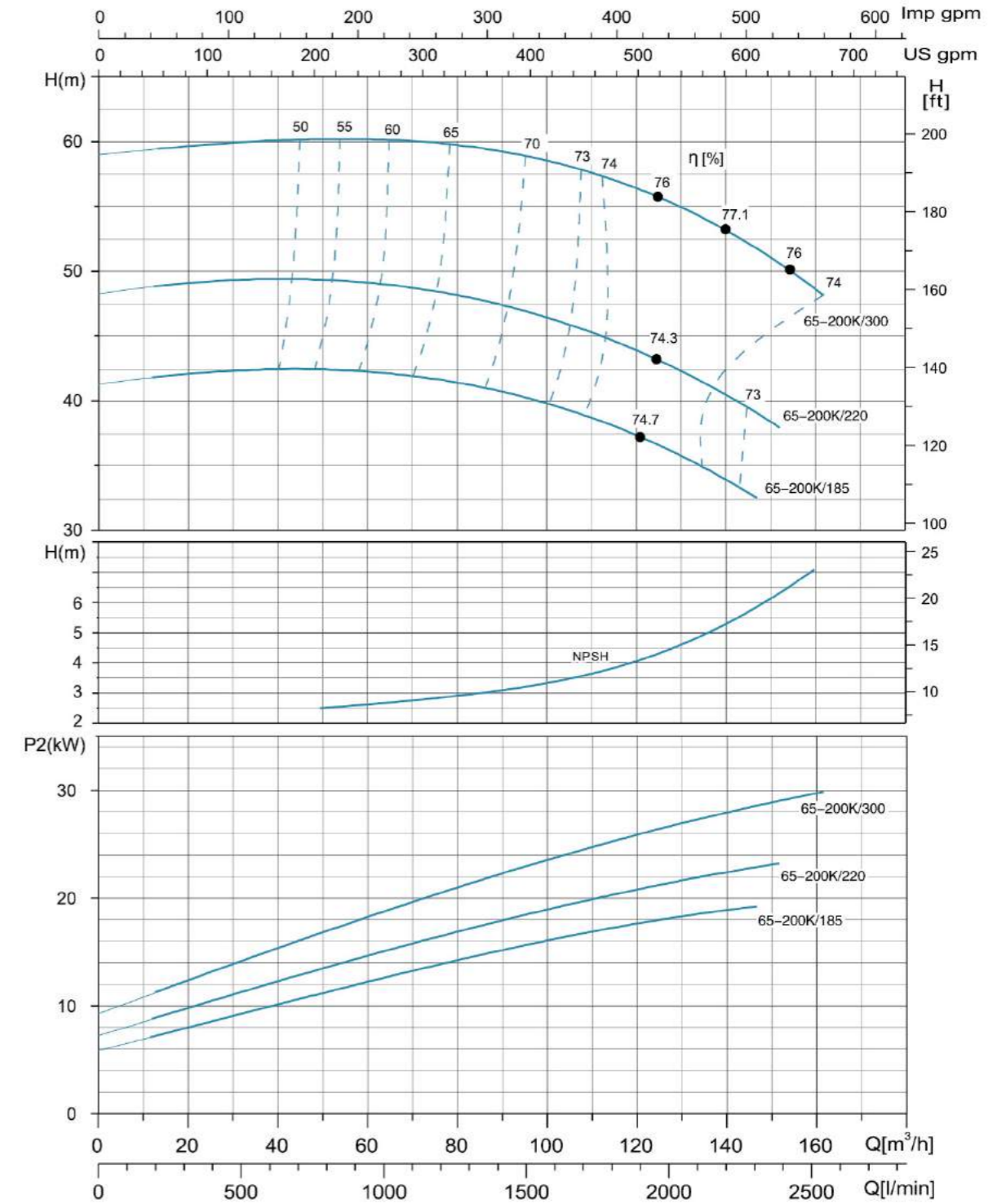



Hydraulic Performance Curves

<b>XST65-250</b>	<b>~2900rpm</b>	<b>ISO 9906 Annex A</b>
------------------	-----------------	-------------------------

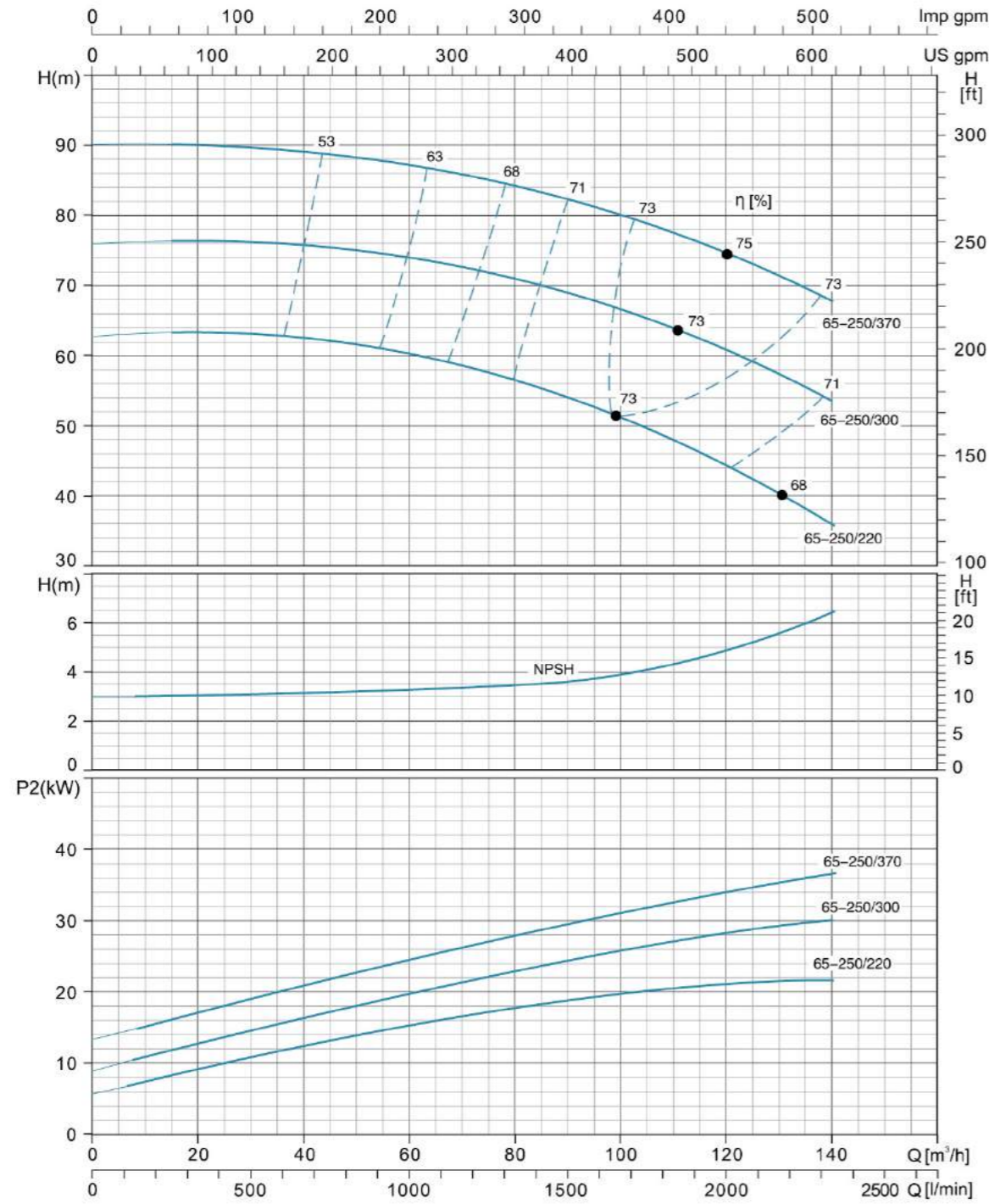

Hydraulic Performance Curves

<b>XST80-160</b>	<b>~2900rpm</b>	<b>ISO 9906 Annex A</b>
------------------	-----------------	-------------------------

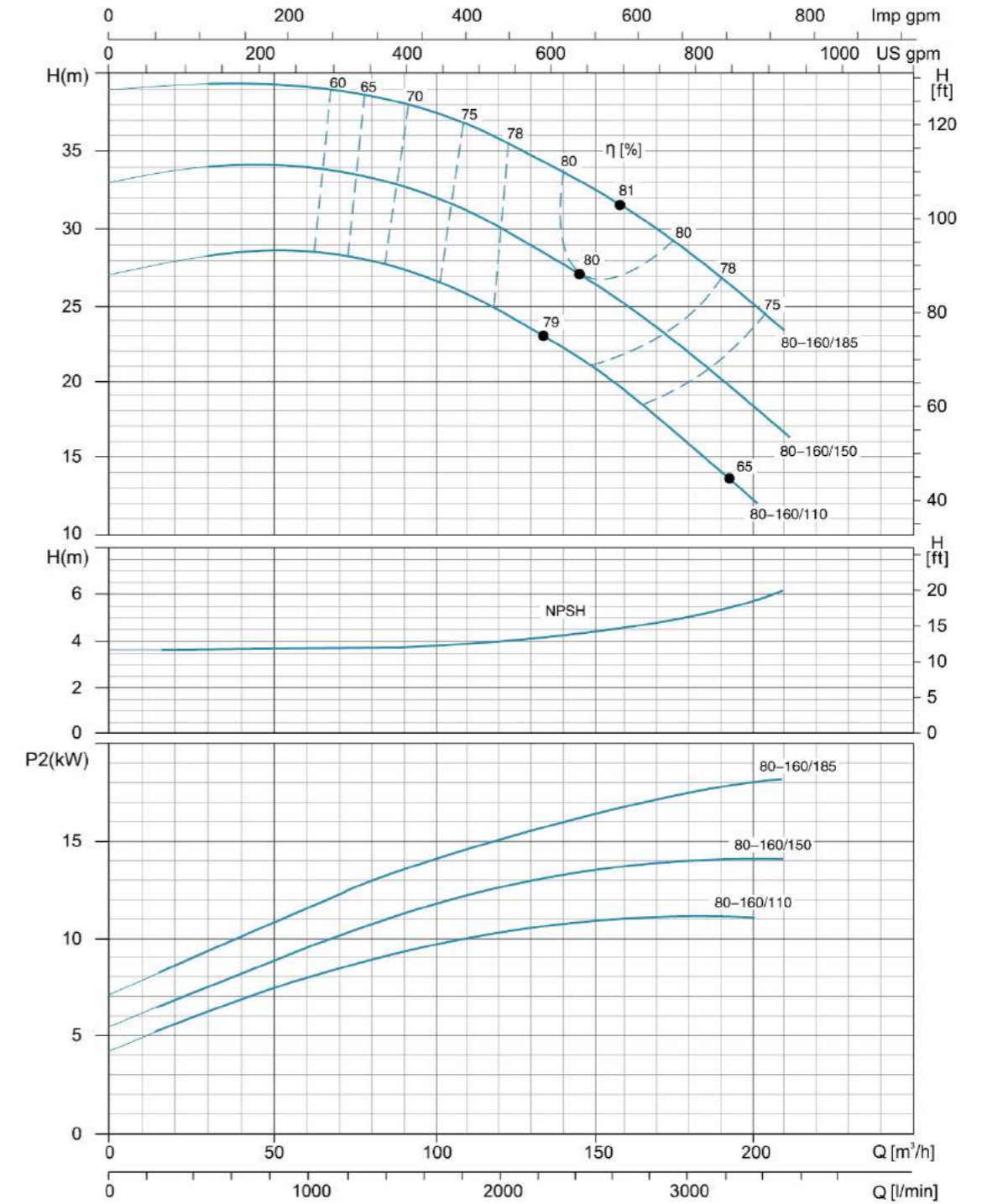



Hydraulic Performance Curves

XST80-200	~2900rpm	ISO 9906 Annex A
-----------	----------	------------------

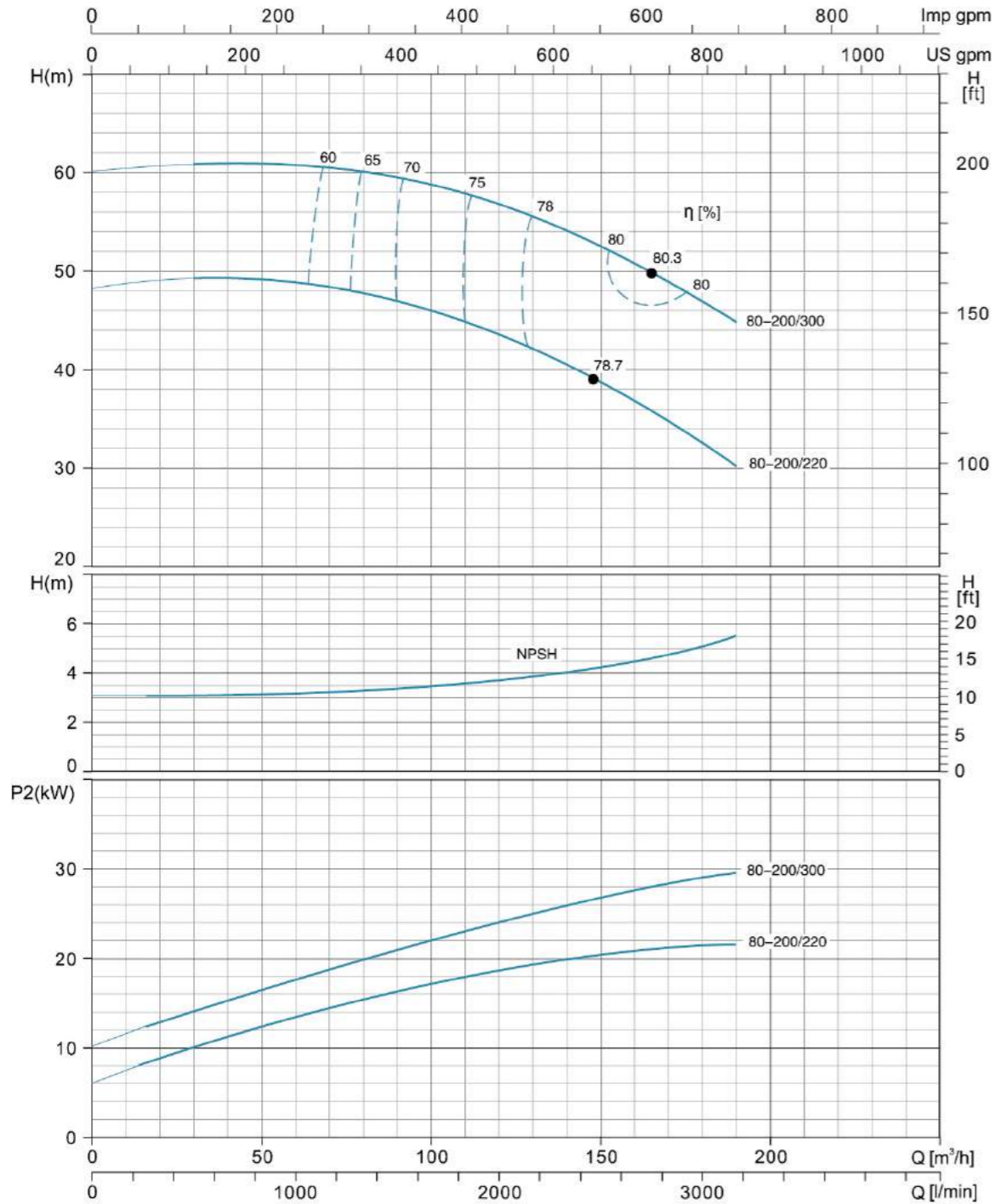

Hydraulic Performance Curves

XST80-250	~2900rpm	ISO 9906 Annex A
-----------	----------	------------------

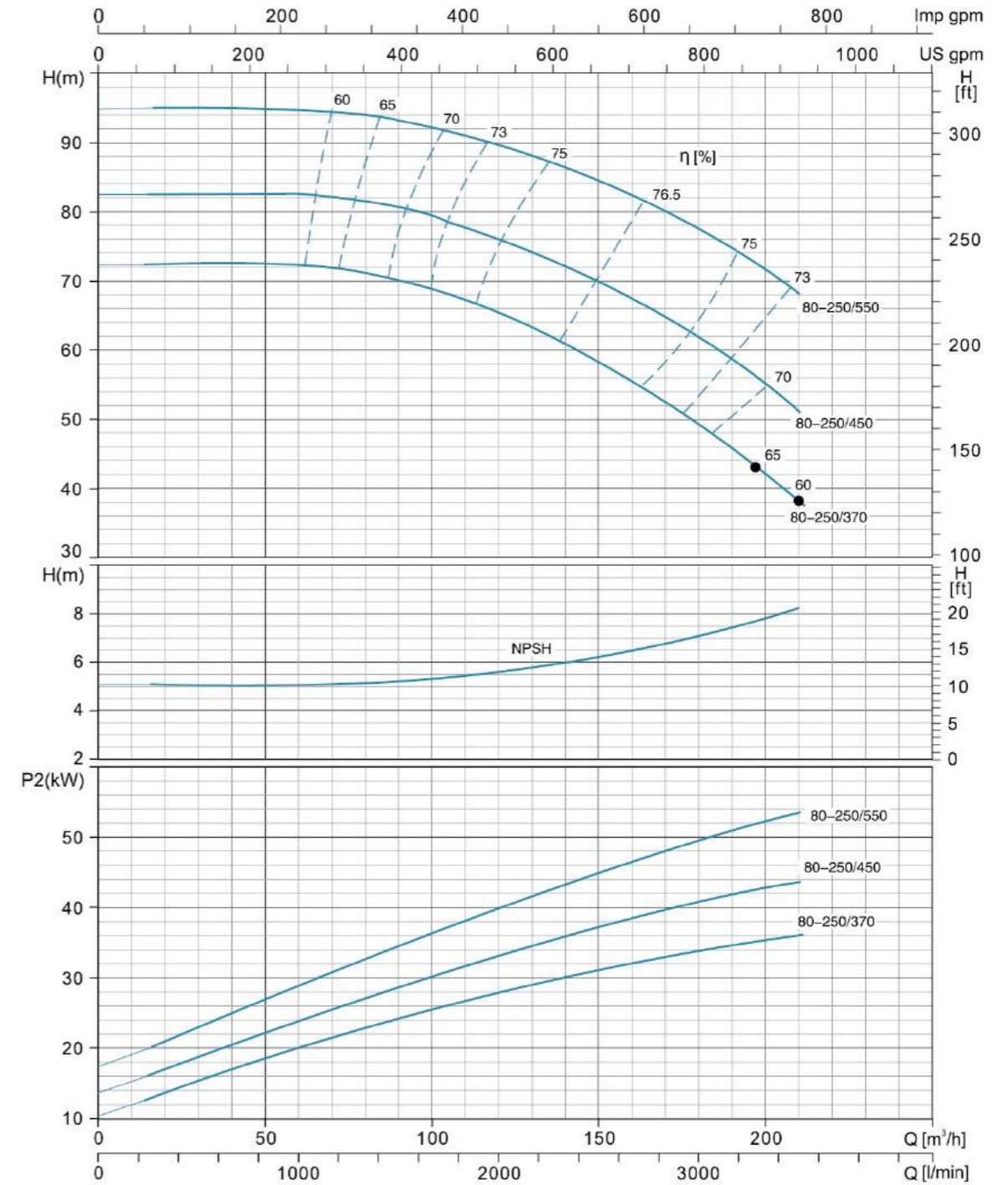



**Flange Dimensions**

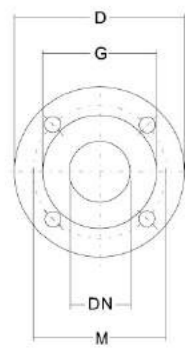

**PN16 FLANGES**

DN	D	M	G	HOLES N°	∅	MAX. THICKNESS
32	140	100	78	4	18	18
40	150	110	88	4	18	18
50	165	125	102	4	18	20
65	185	145	122	4	18	20

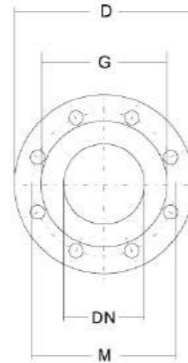

**PN16 FLANGES**

DN	D	M	G	HOLES N°	∅	MAX. THICKNESS
80	200	160	138	8	18	22
100	220	180	158	8	18	22

**Installation Sketch**  
up to 7.5 kW included

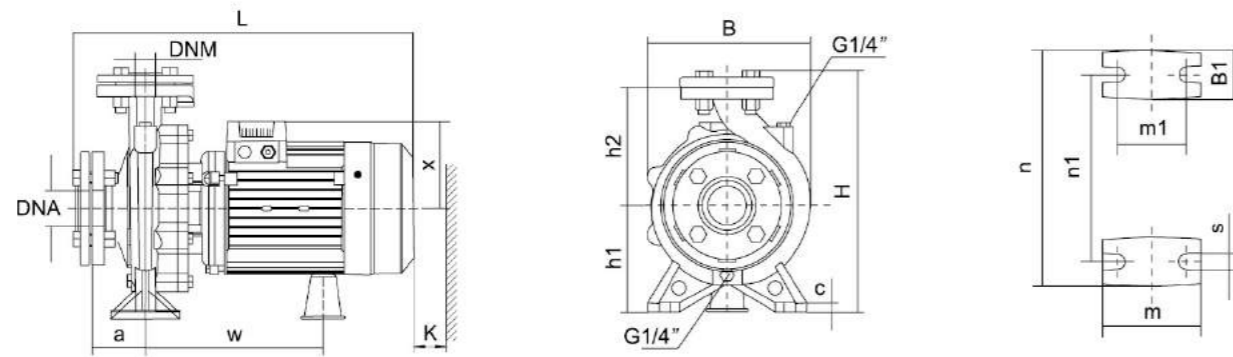

MODEL	DNM	DNA	a	w	x	h2	B1	c	h1	m	m1	n	n1	s	B	H	L	K																
32-125/7	32	50	80	223	113	140	48	12	112	100	70	190	140	15	192	281	427	85																
32-125/11																																		
32-160/15																																		
32-160/22																																		
32-160/30																																		
32-200/30			155	264	180	198	60	15	160	240	190	15	248	369	490	60																		
32-200/40																																		
32-250/55																																		
32-250/75																																		
40-125/11																	40	65	80	255	127	140	45	12	112	100	70	210	160	218	282	489	95	
40-125/15																																		
40-125/22																																		
40-160/30																																		
40-160/40																																		
40-200/55	100	259	180	180	50	160	264	212	15	275	370	553	583	105																				
40-200/75																																		
50-125/22															50	65			100	262	127	160	50	12	132	100	70	240	190	243	322	518	110	
50-125/30																																		
50-125/40																																		
50-160/55																																		
50-160/75																																		
65-125/40	65	80	100	262	180	180	52	160	264	212	272	370	556	586			110																	
65-125/55																																		
65-125/75																																		
65-125/40																		65	80	100	265	180	180	68	14	160	125	95	280	212	283	372	564	594
65-125/55																																		
65-125/75																																		

**Installation Sketch**

From 7.5 kW

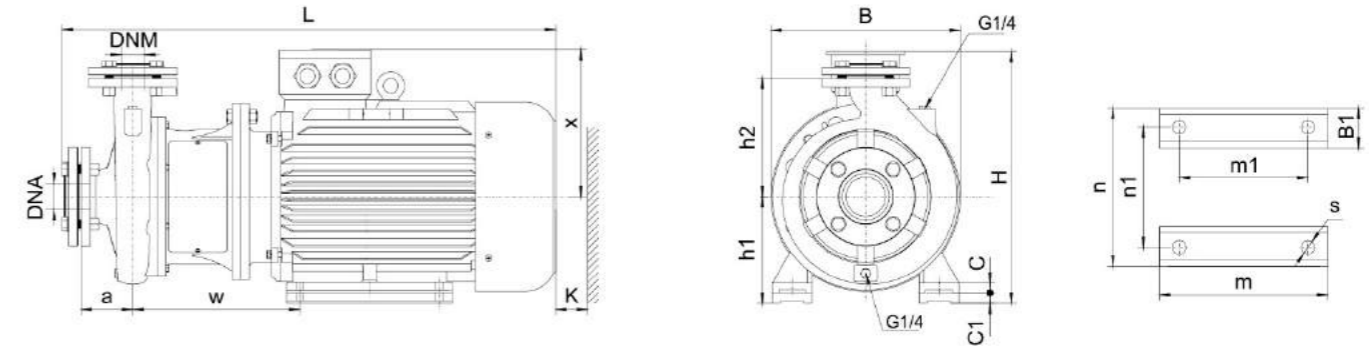

MODEL	DNM	DNA	a	w	x	h2	B1	C	C1	h1	m	m1	n	n1	s	B	H	L	K			
40-250/92	40	65	100	310	260	225	65	20	20	180	260	210	320	254	14.5	350	440	845	110			
40-250/110																						
40-250/150																						
50-200/92	50	65	100	310	260	200	65	20	-	160	260	210	320	254	14.5	350	420	845	120			
50-200/110																						
50-250/150																						
50-250/185																						
50-250/220																						
65-160/92				65	80	100	323	275	225	70	22	-	180	311	241	355	279	14.5	355	455	925	125
65-160/110																						
65-160/150																						
65-200/150																						
65-200/185																						
65-200/220																						
65-200K/185	70	25	25				304	254	320	254	355	279	18.5	311	241	355	279	14.5	400	505	1026	
65-200K/220																						
65-200K/300																						
65-250/220																						
65-250/300																						
65-250/370	80	100	125	315	260	225	65	20	-	160	260	210	320	254	14.5	350	420	870	130			
80-160/110																						
80-160/150																						
80-160/185																						
80-200/220																						
80-200/300				70	25	25	180	311	241	355	279	18.5	200	369	305	395	318	18.5	400	505	1050	
80-250/370																						
80-250/450																						
80-250/550																						
80-250/550																						



## Identification Codes

24 V T T S - G1 S

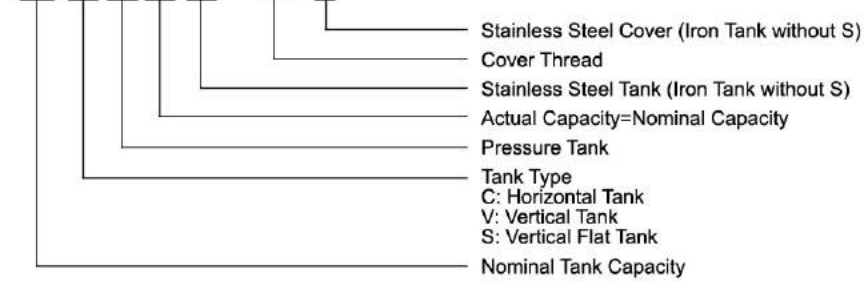

## Tank



Model	Max. Pressure (bar)	Nominal Capacity (L)	Actual Capacity (L)	Membrane	Max. Temp	Connection
5STT	6	5	5	EPDM	90°C	G1"
24ST	8	24	20	EPDM	90°C	G1"
24STT	8	24	24	EPDM	90°C	G1"

The service life of the membrane is 50,000 cycles.



Model	Max. Pressure (bar)	Nominal Capacity (L)	Actual Capacity (L)	Membrane	Max. Temp	Connection
2VT	8	2	2	EPDM	99°C	G1/2"
4VT	8	4	4	EPDM	99°C	G1"
8VT	8	8	8	N.R	99°C	G1"
19VT	8	19	18	EPDM	99°C	G1"
24VT	8	24	20	EPDM	99°C	G1"
24VTT	8	24	24	EPDM	99°C	G1"

The service life of the membrane is 50,000 cycles.



Model	Max. Pressure (bar)	Nominal Capacity (L)	Actual Capacity (L)	Membrane	Max. Temp	Connection
19CT	8	19	18	EPDM	99°C	G1"
24CT	8	24	20	EPDM	99°C	G1"
24CTT	8	24	24	EPDM	99°C	G1"
50CT	8	50	36	EPDM	99°C	G1"
50CTT	8	50	50	EPDM	99°C	G1"
60CTT	8	60	60	EPDM	99°C	G1"
100CT	8	100	80	EPDM	99°C	G1"
100CTT	8	100	100	EPDM	99°C	G1"

The service life of the membrane is 50,000 cycles.



Model	Max. Pressure (bar)	Nominal Capacity (L)	Actual Capacity (L)	Membrane	Max. Temp	Connection
50FT	8	50	36	EPDM	99°C	G1"
50FTT	8	50	50	EPDM	99°C	G1"
60FTT	8	60	60	EPDM	99°C	G1"
100FT	8	100	80	EPDM	99°C	G1"
100FTT	8	100	100	EPDM	99°C	G1"
200FTT	10	200	200	BUTLY	99°C	G1 1/2"
300FTT	10	300	300	BUTLY	99°C	G1 1/2"

The service life of the membrane is 50,000 cycles.

## 3-Way/5-Way



Model	Connection	Length
3TA	G1"	70.80
5TA	G1"	80.90
5TB	G1"	80.90

## Foot Valve



Model	Connection
FVA1	1"
FVA1.25	1 1/4"
FVA1.5	1 1/2"
FVA2	2"
FVA3	3"

- Stainless steel mesh
- Can be used as a check valve

## Flexible Hose



Model	FH12.8-01 (L=128mm)	FH44-03 (L=440mm)
Inlet	G 1/4"	G1"
Outlet	G 3/8"	G1"
Material	Stainless steel wire	Stainless steel wire
Operating Limits	Fluid temperature up to 35°C; Maximum ambient temperature 40°C.	

## Filter



Model	WF-01A	WF-02A
Inlet/Outlet	1" x 1"	1" x 1"
Capacity	1L	2L
Max. Pressure	5bar	5bar
Operating Limits	Fluid temperature up to 35°C; Maximum ambient temperature 40°C.	



## Pressure Switch



PS-02B

- High precision
- High sensitivity
- Adjustable pressure range 1.4-5.6 bar
- G1/4"



PS-02C

- High precision
- High sensitivity
- Adjustable pressure range 1.4-5.6 bar
- G1/4"

## Pressure Gauge



Axial



Radial

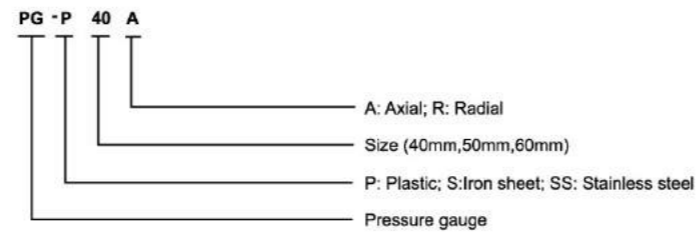

- Two connection types: (1)G1/4" (2)M10×1
- For 40mm gauge, the scale: 0-6 bar
- For 50mm gauge, the scale: 0-10 bar or 0-6 bar
- Back/bottom connection

## Electromagnetic Switch



PS-04A

RATED VOLTAGE	220V-240V/110V-120V
FREQUENCY	50/60Hz
MAX. CURRENT	10A
MAX. POWER	1.1kW/1.5kW
STARTING PRESSURE SETTING	1.2bar/1.5bar/2.2bar
MAX. OPERATING PRESSURE	10bar
CONNECTION THREAD	G1"
PROTECTION CLASS	IP65
MAX. OPERATING TEMPERATURE	60°C
CABLE REQUIREMENT	Cable diameter 7.5-9mm



PS-04B

RATED VOLTAGE	220V-240V/110V-120V
FREQUENCY	50/60Hz
MAX. CURRENT	10A
MAX. POWER	1.1kW/1.5kW
STARTING PRESSURE SETTING	1.2bar/1.5bar/2.2bar
MAX. OPERATING PRESSURE	10bar
CONNECTION THREAD	G1"
PROTECTION CLASS	IP65
MAX. OPERATING TEMPERATURE	60°C
CABLE REQUIREMENT	Cable diameter 7.5-9mm

Optional: Working pressure adjustable



PS-04C

RATED VOLTAGE	220V-240V/110V-120V
FREQUENCY	50/60Hz
MAX. CURRENT	10A
MAX. POWER	1.1kW/1.5kW
STARTING PRESSURE SETTING	1.5bar/2.2bar
MAX. OPERATING PRESSURE	10bar
CONNECTION THREAD	G1"
PROTECTION CLASS	IP54
MAX. OPERATING TEMPERATURE	60°C
CABLE REQUIREMENT	Cable diameter 7.5-9mm











## Pump Range



● Peripheral Pump



● Self-Priming Peripheral Pump



● Jet Pump



● Jet Pump for Deep Wells



● Centrifugal Pump



● Multistage Centrifugal Pump



● Self-Priming Centrifugal Pump



● Stainless Steel Multistage Centrifugal Pump



● Stainless Steel Centrifugal Pump



● Submersible Pump



● Stainless Steel Submersible Pump



● Stainless Steel Submersible Sewage Pump



● Flexible Shaft Pump



● Domestic Lifting Station



● Pool Pump



● Garden Submersible Pump



● Garden Jet Pump



● Pressure Booster System



● Fountain Pump



● Standard Centrifugal Pump

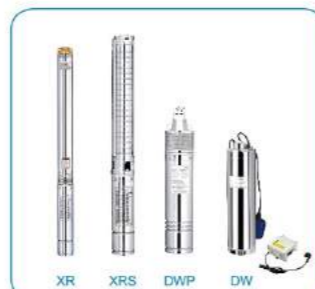

● Submersible Borehole Pump



● Gasoline/Diesel Water Pump



● Booster Pump/Circulation Pump

## Pump Range



● Submersible Sewage Pump



● Submersible Sewage Pump



● Submersible Dewatering Pump



● Submersible Slurry Pump



● Stainless Steel Vertical Multistage Pump



● Stainless Steel Horizontal Multistage Pump



● Semi-open Impeller Stainless Steel Centrifugal Pump



● Stainless Steel Standard Centrifugal Pump



● Pressure Booster System



● Vertical In-line Pump



● Bare Shaft End Suction Centrifugal Pump



● End Suction Centrifugal Pump