

# YK700XGP

Dust-proof & drip-proof type

- Arm length 700mm
- Maximum payload 18kg

## Ordering method

<b>YK700XGP</b>	<b>F</b>	<b>RCX240</b>	<b>R3</b>	<b>BB</b>							
<b>Model</b>	<b>Z axis stroke</b>	<b>Tool flange</b>	<b>Cable</b>	<b>Controller</b>	<b>Usable for CE</b>	<b>Regenerative unit</b>	<b>Expansion I/O</b> <sup>Note 1</sup>	<b>Network option</b>	<b>iVY System</b>	<b>Gripper</b>	<b>Battery</b>
	200: 200mm 400: 400mm	F: With tool flange	3L: 3.5m 5L: 5m 10L: 10m		No entry: Standard E: CE marking	R3: RGU-3	N, P: Standard I/O 16/8 N1, P1: 40/24 N2, P2: 64/40 N3, P3: 88/56 N4, P4: 112/72	No entry: None CC: CC-Link DN: DeviceNet PB: Profibus EN: EtherNet EP: EtherNet/IP YC: YC-Link <sup>Note 2</sup>	No entry: None VY: iVY (Vision) TR: iVY+Light +Tracking LC: iVY+Light	No entry: None GR: Gripper	BB: 4 pcs

Note 1. Use N to N4 when NPN is selected on the I/O board, and P to P4 when PNP is selected.  
Note 2. Available only for the master.

## Specifications

		X-axis	Y-axis	Z-axis	R-axis
<b>Axis specifications</b>	<b>Arm length (mm)</b>	300	400	200   400	-
	<b>Rotation angle (°)</b>	+/-130	+/-150	-	+/-360
<b>AC servo motor output (W)</b>		750	400	400	200
<b>Deceleration mechanism</b>	<b>Speed reducer</b>	Harmonic drive	Harmonic drive	Ball screw	Harmonic drive
	<b>Transmission method</b>	Direct-coupled			
	<b>Motor to speed reducer</b> <b>Speed reducer to output</b>	Direct-coupled			
<b>Repeatability</b> <sup>Note 1</sup> (XYZ: mm) (R: °)	+/-0.02		+/-0.01		+/-0.004
<b>Maximum speed (XYZ: m/sec) (R: °/sec)</b>		8.4		2.3   1.7	920
<b>Maximum payload (kg)</b>		18			
<b>Standard cycle time: with 2kg payload</b> <sup>Note 2</sup> (sec)		0.52			
<b>R-axis tolerable moment of inertia</b> <sup>Note 3</sup> (kgm <sup>2</sup> )		1.0			
<b>Protection class</b> <sup>Note 4</sup>		Equivalent to IP65 (IEC 60529)			
<b>User wiring (sq x wires)</b>		0.2x20			
<b>User tubing (Outer diameter)</b>		φ6x3			
<b>Travel limit</b>		1.Soft limit 2.Mechanical stopper (X,Y,Z axis)			
<b>Robot cable length (m)</b>		Standard: 3.5 Option: 5,10			
<b>Weight (kg)</b>		Z axis 200mm: 54 Z axis 400mm: 56			

Note 1. This is the value at a constant ambient temperature. (X,Y axes)  
Note 2. When reciprocating 25mm in vertical direction and 300mm in horizontal direction (rough-positioning arch motion).  
Note 3. There are limits to acceleration coefficient settings.  
Note 4. Do not use robots where the bellows section is directly exposed to water jet. Contact our distributor for information on drip-proof structure preventing liquid other than water.

## Controller

Controller	Power capacity (VA)	Operation method
RCX240-R3	2500	Programming / I/O point trace / Remote command / Operation using RS-232C communication

Note. The movement range can be limited by changing the positions of X and Y axis mechanical stoppers. (The movement range is set to the maximum at the time of shipment.)  
See our robot manuals (installation manuals) for detailed information.  
Note. To set the standard coordinates with high accuracy, use a standard coordinate setting jig (option). Refer to the user's manual (installation manual) for more details.

Our robot manuals (installation manuals) can be downloaded from our website at the address below:  
<http://www.yamaha-motor.co.jp/global/industrial/robot/>

## YK700XGP

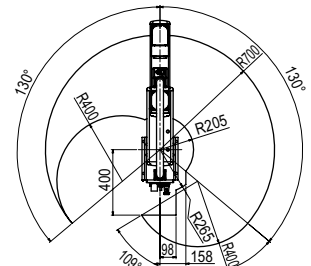
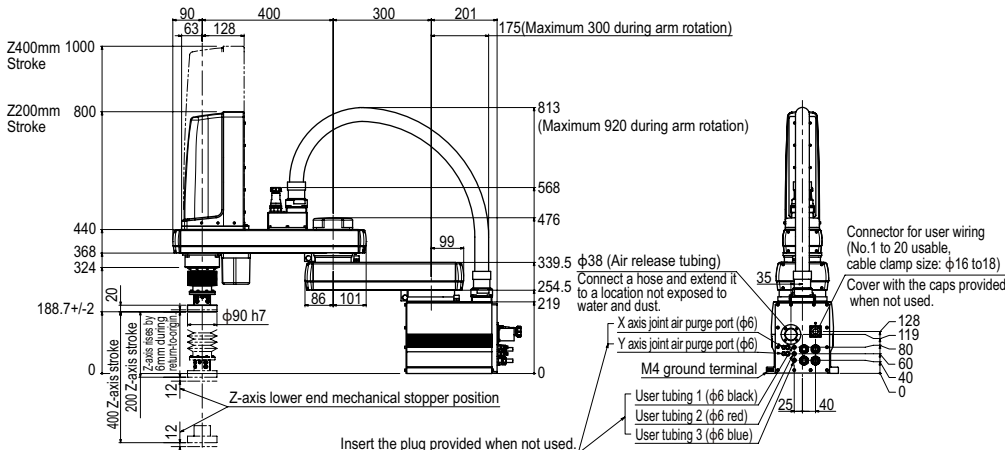
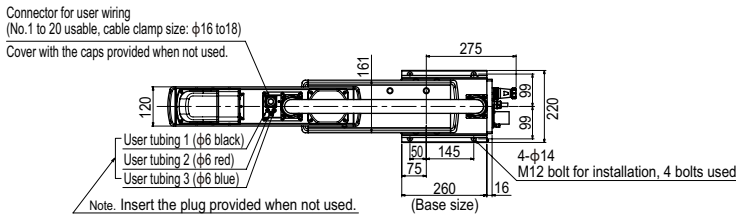

Working envelope of left-handed system

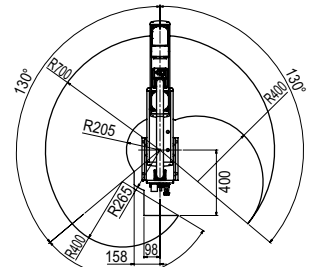

Working envelope of right-handed system

- Note that the robot cannot be used at a position where the base flange, robot cable, spline, and bellows interfere with each other in the working envelope shown above.
- X-axis mechanical stopper position : 132°
- Y-axis mechanical stopper position : 152°

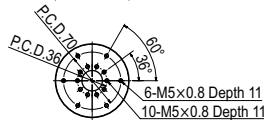
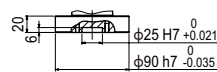

Z axis tip shape

\* There is no phase relation between each position of M5 tapped holes and R-axis origin position.

APPLICATION  
TRANSERO  
FLIP-X  
PHASER  
XY-X  
YK-XG  
YP-X  
CLEAN  
CONTROLLER INFORMATION  
Orbit type  
T-tray type  
Small type  
Medium type  
Large type  
Wall-mount / Inverse type  
Dust-proof & drip-proof type