

# YK250XGP

Dust-proof & drip-proof type

- Arm length 250mm
- Maximum payload 4kg

## Ordering method

<b>YK250XGP - 150</b>				<b>RCX240</b>					<b>BB</b>
<b>Model</b>	<b>Z axis stroke</b>	<b>Tool flange</b>	<b>Cable</b>	<b>Controller</b>	<b>Usable for CE</b>	<b>Expansion I/O</b> <small>Note 1</small>	<b>Network option</b>	<b>iVY System</b>	<b>Battery</b>
	150: 150mm	No entry: None F: With tool flange	3L: 3.5m 5L: 5m 10L: 10m		No entry: Standard E: CE marking	N, P: Standard I/O 16/8 N1, P1: 40/24 N2, P2: 64/40 N3, P3: 88/56 N4, P4: 112/72	No entry: None CC: CC-Link DN: DeviceNet PB: Profibus EN: Ethernet YC: YC-Link <small>Note 2</small>	No entry: None VY: iVY (Vision) TR: iVY+Light +Tracking LC: iVY+Light	BB: 4 pcs

Note 1. Use N to N4 when NPN is selected on the I/O board, and P to P4 when PNP is selected.  
Note 2. Available only for the master.

## Specifications

		X-axis	Y-axis	Z-axis	R-axis
<b>Axis specifications</b>	<b>Arm length (mm)</b>	100	150	150	-
	<b>Rotation angle (°)</b>	+/-129	+/-134	-	+/-360
<b>AC servo motor output (W)</b>		200	150	50	100
<b>Deceleration mechanism</b>	<b>Speed reducer</b>	Harmonic drive	Harmonic drive	Ball screw	Harmonic drive
	<b>Transmission method</b>	Direct-coupled			
	<b>Motor to speed reducer</b> <b>Speed reducer to output</b>	Direct-coupled			
<b>Repeatability</b> <small>Note 1</small> (XYZ: mm) (R: °)		+/-0.01		+/-0.01	+/-0.004
<b>Maximum speed (XYZ: m/sec) (R: °/sec)</b>		4.5		1.1	1020
<b>Maximum payload (kg)</b>		4			
<b>Standard cycle time: with 2kg payload</b> <small>Note 2</small> (sec)		0.57			
<b>R-axis tolerable moment of inertia</b> <small>Note 3</small> (kgm <sup>2</sup> )		0.05			
<b>Protection class</b> <small>Note 4</small>		Equivalent to IP65 (IEC 60529)			
<b>User wiring (sq x wires)</b>		0.2x10			
<b>User tubing (Outer diameter)</b>		φ4x4			
<b>Travel limit</b>		1.Soft limit 2.Mechanical stopper (X,Y,Z axis)			
<b>Robot cable length (m)</b>		Standard: 3.5 Option: 5,10			
<b>Weight (kg)</b>		21.5			

Note 1. This is the value at a constant ambient temperature. (X,Y axes)  
Note 2. When reciprocating 25mm in vertical direction and 300mm in horizontal direction (rough-positioning arch motion).  
Note 3. There are limits to acceleration coefficient settings.  
Note 4. Do not use robots where the bellows section is directly exposed to water jet. Contact our distributor for information on drip-proof structure preventing liquid other than water.

## Controller

Controller	Power capacity (VA)	Operation method
RCX240	1000	Programming / I/O point trace / Remote command / Operation using RS-232C communication

## YK250XGP

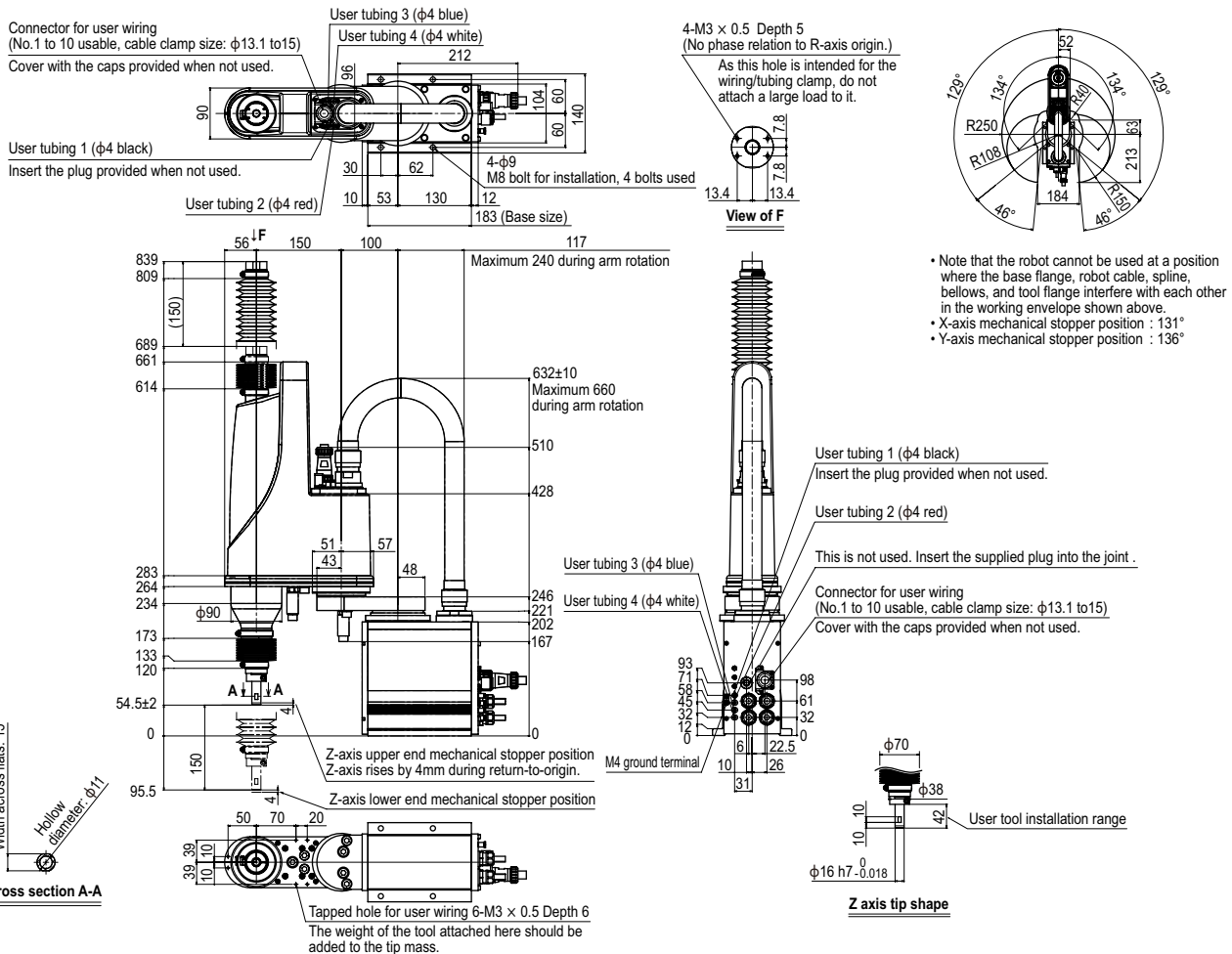

## YK250XGP Tool flange mount type

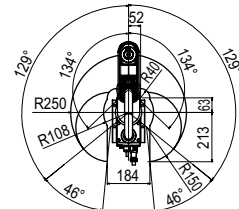
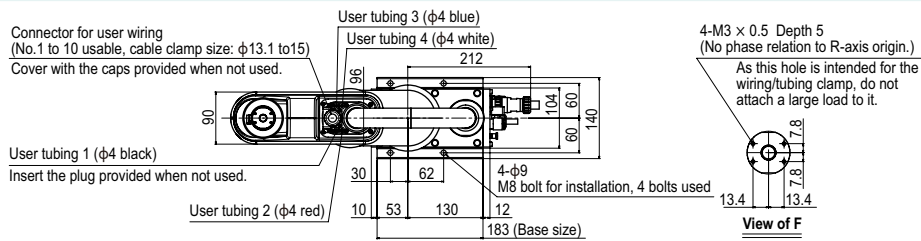

- Note that the robot cannot be used at a position where the base flange, robot cable, spline, bellows, and tool flange interfere with each other in the working envelope shown above.
- X-axis mechanical stopper position :  $131^\circ$
- Y-axis mechanical stopper position :  $136^\circ$

