

Polishing Machine for Improved Product Quality

RICE POLISHING MACHINE

KB40G

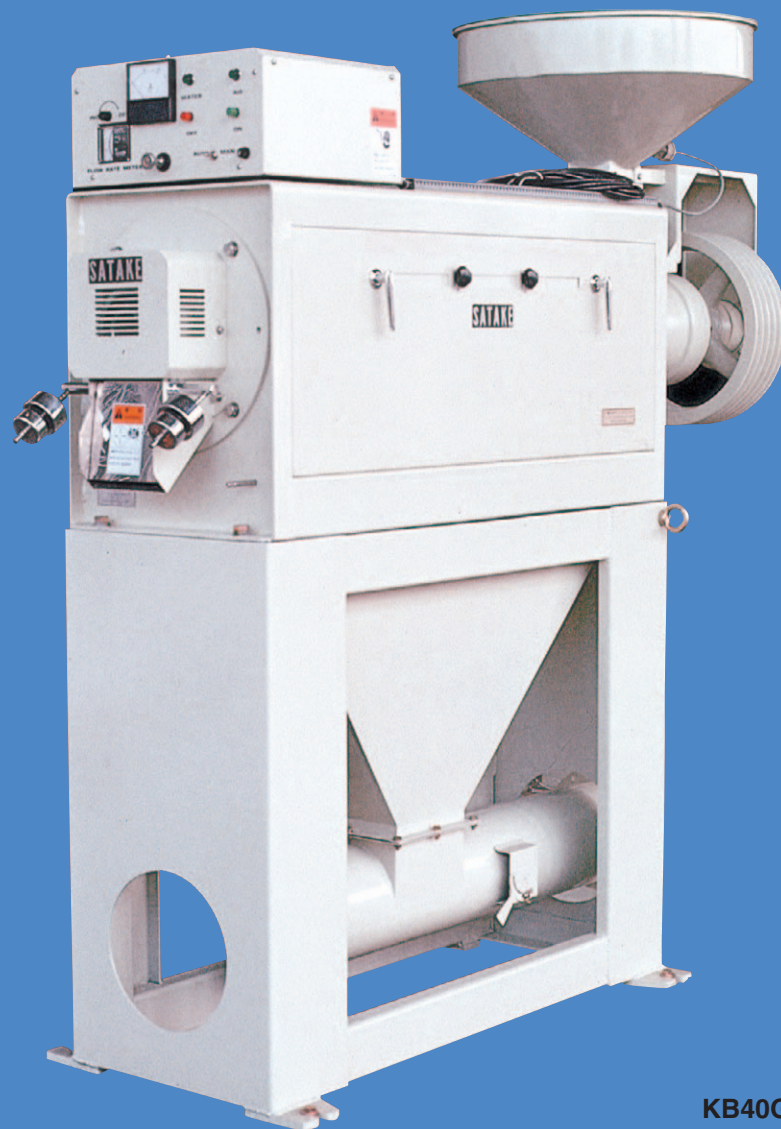

KB40G-TA

SATAKE CORPORATION

The Satake Rice Polishing Machine cleans the surface of rice, significantly enhancing the quality of finished products. The machine has achieved a high reputation in many countries for its high performance and for the innovations which have been incorporated over the past 20 years.

FEATURES:

1. Improves the appearance of rice:

The surface of milled rice becomes smooth and clean, leading to enhanced commercial value.

2. Improves the quality of rice:

The residual bran absorbs moisture and helps microorganisms to develop. By removing this residual bran, The Satake KB gives rice a longer shelf life.

3. Gentle polishing:

The Satake KB is designed to minimize breakage of rice kernels. Milling rolls and screens are chosen to best fit the material.

4. Wide applications:

Combination with other Satake Milling Equipment enables application to wide varieties of rice, and even to other grains such as maize.

RICE POLISHING MACHINE

Specifications

Model	KB40G
Required Power (kW)	22 or 30 (6P)
Input Capacity (t/hr)	3.0 ~ 4.0

Dimensions

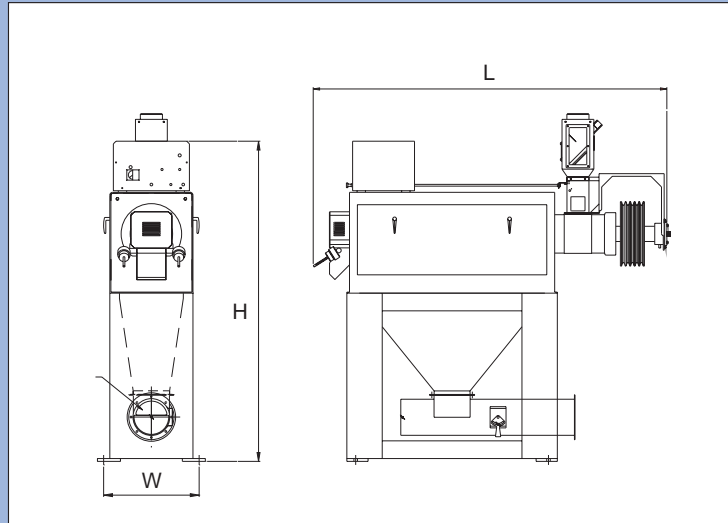

Model	W(mm)	L(mm)	H(mm)	Weight (kg)	Volume (m³)
KB40G	540	2,150	1,800	1,040 *	4.5 **

* Approximate Shipping Weight (w machine stand, w/o motor)

**Approximate Shipping Volume

Other Applications



KB placed after Satake Rice Whitener (VTA,VBF) improves the milling yield for tender grains like Basmati.

(The number and combination of machines are dependent on materials.)

All Satake products are the subject of continuous development and, as a result, their specification may change and differ in detail from those shown.

SATAKE CORPORATION is registered with ISO9001 standards for quality management systems and ISO14001 standards for environmental management systems.



ISO9001



ISO14001

SATAKE CORPORATION

Head Office
2-30, Saijo-Nishihonmachi, Higashi-Hiroshima, 739-8602, Japan
Tel : +81-824-20-8560/8539
Fax : +81-824-20-0865
e-mail: kg-hiroshima@satake-japan.co.jp
URL : www.satake-japan.co.jp

UK Division
P.O.Box 53, Bredbury, Stockport, Cheshire, SK6 2FG, England
Tel : +44-161-406-3800
Fax : +44-161-406-3801
e-mail : sales@satake.co.uk
URL : www.satake.co.uk

New Delhi Office
11th Floor, Dr. Gopal Das Bhaven, 28 Barakhamba Road, New Delhi 110001 India
Tel : +91-11-3738646
Fax : +91-11-3738647

Beijing Office
Room 203B, Chang Xin Building, No.39 An Ding Road,Chao Yang District,Beijing, P.R. China
Tel : +86-10-6443-3822
Fax : +86-10-6443-4188

Bangkok Office
133 Moo 5, Bangkadi Industrial Park Tivanon, Road, Patumthani 12000 Thailand
Tel : +66-2-501-1223
Fax : +66-2-501-1225
e-mail : sataketh@asia.com

Yangon Office
No.4 Kanthaya Street, South Okkalapa Township, Yangon Myanmar
Tel : +95-1-578303
Fax : +95-1-570610

SATAKE USA INC.
9800 Townpark, Houston, Texas 77036 U.S.A.
Tel : +1-713-772-8400
Fax : +1-713-772-8484
e-mail : rice@satake-usa.com
URL : www.satake-usa.com

SATAKE AUSTRALIA PTY. LTD.
23-25 Marigold Street, Revesby, NSW 2212 Australia
Tel : +61-2-9774-1155
Fax : +61-2-9774-1248
e-mail : sataus@ozemail.com.au
URL : www.satake.com.au

SATAKE (THAILAND) CO., LTD.
133 Moo 5, Bangkadi Industrial Park Tivanon Road, Patumthani 12000 Thailand
Tel : +66-2-501-1180
Fax : +66-2-501-1188
e-mail : sataketh@asia.com

SATAKE MANUFACTURING (SUZHOU) CO., LTD.
Jin Feng Road, Suzhou New District, Suzhou City, Jiangsu Province P.R.China
Tel : +86-512-6536-8225
Fax : +86-512-6536-3004
URL : www.satake-suzhou.com.cn

SATAKE (CANADA) INC.
2550 Argentia Road, Suite 119 Mississauga, Ontario L5N 5R1 Canada
Tel : +1-905-858-0791
Fax : +1-905-858-0957

SATAKE AMERICA LATINA LTDA.
Conjunto Empresarial Joinville Rua Xavantes, 155-Bairro Atradores 89203-210-Joinville-Santa Catarina, Brazil
Tel : +55-47-438-0413
Fax : +55-47-438-7932
e-mail : ricardo@satake.com.br