

Polishing Machine for Improved Product Quality

RICE POLISHING MACHINE

KB60GS-T



KB60GS-T

The Satake Rice Polishing Machine KB cleans the surface of rice, significantly enhancing the quality of finished products. The machine has achieved a high reputation in many countries for its high performance and for the innovations which have been incorporated over the past 25 years.

FEATURES:

1. Improves the appearance of rice:

The surface of milled rice becomes smooth and clean, leading to enhance commercial value.

2. Improves the quality of rice:

The residual bran absorbs moisture and helps microorganisms to develop. By removing this residual bran, The Satake KB gives rice a longer shelf life.

3. Gentle polishing:

The Satake KB is designed to minimize breakage of rice kernels. Milling rolls and screens are chosen to best fit the material.

4. Wide applications:

Combination with other Satake milling equipment enables application to wide varieties of rice.

5. Large Capacity

Combination of upper chamber for mixing with mist water and lower chamber for polishing, the capacity has increased almost double, compared with KB40G-TA.

RICE POLISHING MACHINE

Specifications

Model	KB60GS-T
Required Power (kW)	55(6P), 3.7(6P)
Input Capacity (t/h)	4.0~6.5
Required Air Volume (m ³ /min)	35~60
Static Pressure (kPa)	-1.3~-2.0
Net Weight (kg)	910

Dimensions

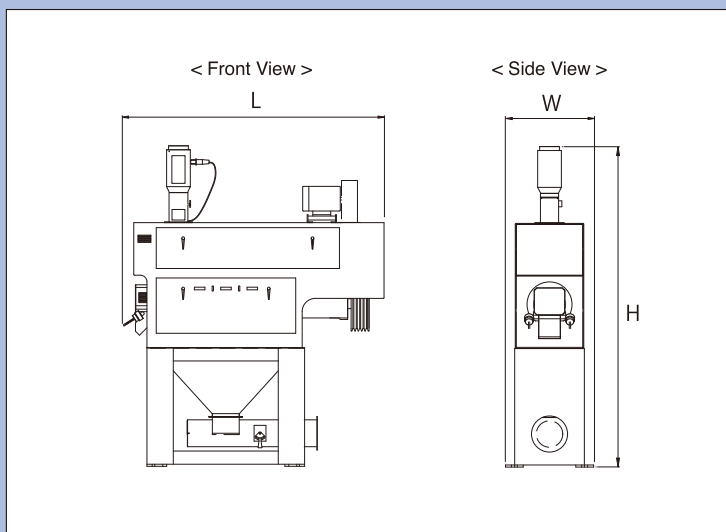

Model	W(mm)	L(mm)	H(mm)
KB60GS-T	669	1,900	1,850

* It is recommended to install a Rotary Sifter just before the machine to remove broken grains and branny material for the following cases:

- a- When processing white rice to produce the best-polished rice.
- b- When using the machine as a rice whitening machine.

All copyright and trademark rights of this catalog belong to Satake Co., unless otherwise noted. Unauthorized copying, reprinting, etc. are forbidden. All Satake products are the subject of continuous development and, as a result, their specification may change and differ in detail from those shown.

SATAKE CORPORATION

Head Office
2-30 Saijo Nishihonmachi,
Higashi-Hiroshima-shi, Hiroshima-ken,
739-8602, Japan
URL : <https://satake-group.com/>

Korea Branch
Alpha mighty Dunsan Building, 13F,
229, Daedeck-daero, Seo-gu, 35229
URL : www.satake-group.com

SATAKE USA INC.
10900 Cash Road,
Stafford, Texas, 77477, U.S.A.
URL : www.satake-usa.com

SATAKE AMERICA LATINA LTDA.
Rua Xavantes, 155-Pav. 20, Bairro
Atradores, CEP 89203-210, Joinville,
Santa Catarina, Brazil
URL : www.satake.com.br

SATAKE EUROPE LTD.
Horsfield Way, Bredbury Industrial Park,
Bredbury, Stockport, Cheshire, SK6 2SU,
U.K.
URL : www.satake-europe.com

SATAKE INDIA ENGINEERING PVT. LTD.
4th Floor, Tower-1, HB Twin Towers, A2,
3, 4, Netaji Subhash Place, Wazirpur
District Centre, New Delhi, 110034, India
URL : www.satakeindia.com

SATAKE (THAILAND) CO., LTD.
133,134 Moo 5, Bangkadi, Mueang
Pathum Thani, Pathum Thani 12000,
Thailand
URL : www.sataketh.com

SATAKE ASIA CO., LTD.
888/84 Mahatun Plaza Bld., 8th Floor,
Ploenchit Rd., Lumpini, Pathumwan,
Bangkok, 10330, Thailand
URL : www.sataketh.com

PT. SATAKE GOBEL INDONESIA
Gedung Surabaya Bumi Mandiri,
Lantai 9, Jalan Jenderal Basuki
Rachmat Nomor 129-137, Unit 905 B,
Indonesia

SATAKE MANUFACTURING (SUZHOU) CO., LTD.
229 Jin Feng Road, Suzhou New
District, Suzhou, Jiangsu Province,
215129, China
URL : www.satake.cn

SATAKE AUSTRALIA PTY. LTD.
15 Leland Street, Penrith, N.S.W.,
2750, Australia
URL : www.satake.com.au

ISO 9001 Certification
(Quality Management Systems)

ISO 14001 Certification
(Environmental Management Systems)

SATAKE CORPORATION has obtained ISO9001 and ISO14001 certification. These international standards for management systems ensure Satake will continue to provide high quality products and services.