

Super Short Hand Pallet Truck

CBY-SD

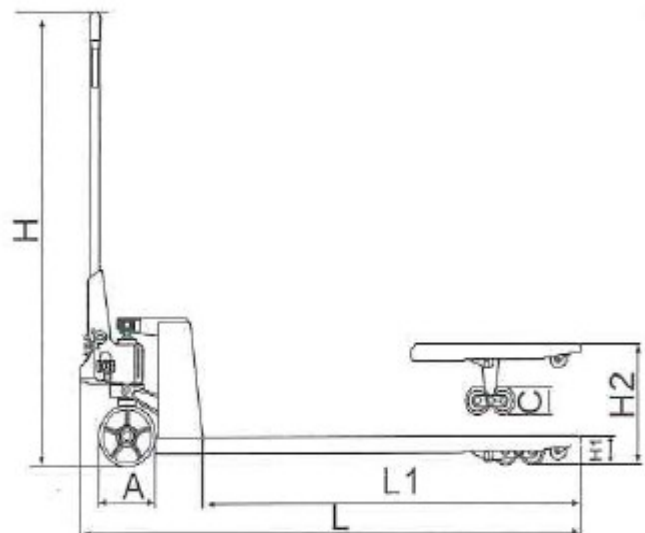

Model	CBY-SD2.0-N	CBY-SD2.0-N	CBY-SD2.0-W	CBY-SD2.5-N	CBY-SD2.5-N	CBY-SD2.5-W
Capacity(kg)	2000			2500		
Width overall forks(mm)(W)	460	550	685	460	550	685
Lifting Height(mm)	195					
Min.fork height(mm)(H1)	85					
Steering wheel(mm)	180x50					
Front Wheel(mm)	80x70					
Fork Length(mm)(L1)	800	800/900		800	800/900	
Self Weight(kg)	65-75					

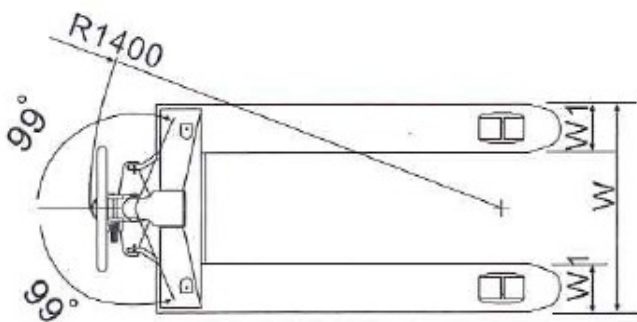

Fu Shen

www.fushenengineering.com



handle A

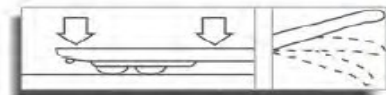

Lower Position



Neutral Position

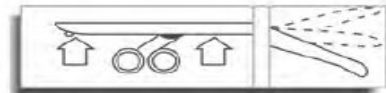

Lifting Position

Lower Position—to lower load, pull up on the finger tip control.

Neutral Position—to place finger tip control lever in this position during pulling the truck or load.

Lift Position—to raise load, push down on finger tip control, pump handle to raise the load.



Option : Single fork wheels
tandem fork wheels



- Option of different coating material for both steering wheel and fork rollers.
- Polyurethane—ideal for delicate floors with hard wearing and non-marking property, quiet and durable.
- Nylon—low drag efforts, high resistance to chemicals, non-marking, preferred in food, fishing and chemical industries with smooth level floors.