

Manual and Electric Version.

- Designed to give the user an ergonomically correct position to reach loads easily without the necessity of bending down or stretching up.
- Handle can be turned and locked in position away from the work area.
- Applies to both sitting and standing positions.
- Forks can be tilted up to 90°.
- Both are supplied as standard with parking brake and foot protectors.
- Conforms to EN1757-1 and EN1175-1.



LT10M



LT10E

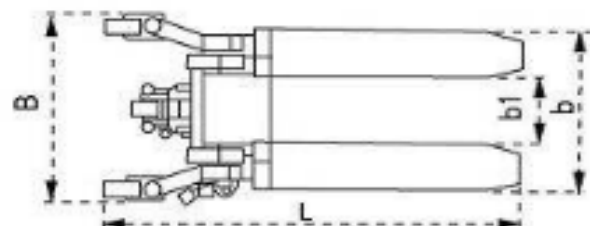
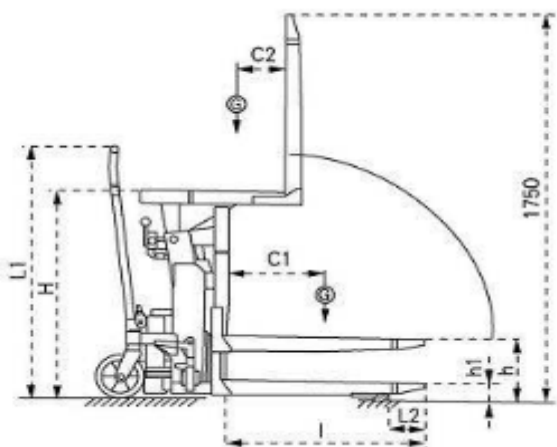

Model		LT10M	LT10E
Type		Manual	Electric
Capacity	(kg)	1000	1000
Lifting Height, Vertical	h (mm)	285	285
Min.Fork Height	h1 (mm)	85	85
Fork Length	l (mm)	800	800
Handle Height	L1 (mm)	1138	1138
Overall Fork Width	b (mm)	520	520
Width Between Forks	b1 (mm)	320	320
Fork Tip Length From Roller	L2 (mm)	135	135
Overall Width	B (mm)	638	638
Overall Length	L (mm)	1325	1410
Overall Height, Raised	H (mm)	950	950
Overall Height, Lowered	H (mm)	750	750
Load Centre Min./Max.	C1 (mm)	200/400	200/400
Load Centre Min./Max.	C2 (mm)	200/420	200/420
Power Unit	(KW/V)	—	0.8/12
Net Weight	(kg)	178	185