

# MACT400 series

## AIR UNIT (F.R.L.UNIT)



### Specification

Model	MACT400		
Components	MAF400, MAR400, MAL400		
Bore No.	8A	10A	15A
Port size	1/4	3/8	1/2
Medium	Air		
Operating pressure range (*)	0.05~1 MPa		
Proof pressure	1.5 MPa		
Effective orifice	24mm <sup>2</sup>	35mm <sup>2</sup>	40mm <sup>2</sup>
Regulated pressure range	0.05~0.85 MPa		
Ambient temperature	- 5~+60°C (No freezing)		
Filter element	Standard: 40μm, Option: 5μm		
Lubricating oil capacity	200c.c		
Min. flow for oil drip	100 ℓ/min	200 ℓ/min	400 ℓ/min
Recommended lubricating oil	Turbine oil ISO-VG32		
Attachment	Pressure gauge (PG-50), bracket		
Weight	2000 g		

### Symbol

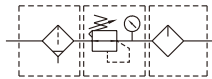

### Order example

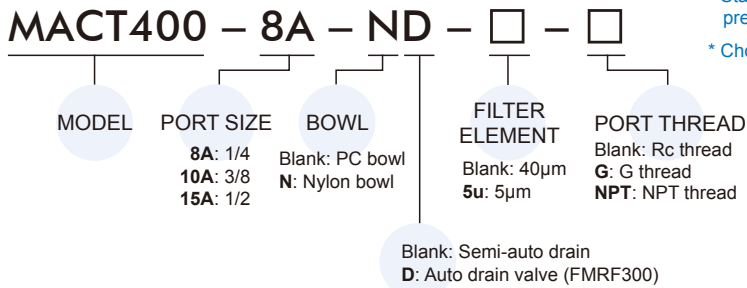

\* Standard unit contains semi-auto-drain function when operating pressure below 0.05 MPa.

\* Choose auto-drain FMRF300, the pressure range is 0.15~1 MPa.

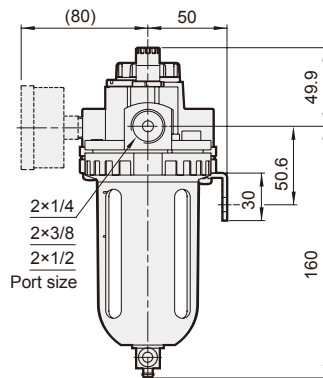
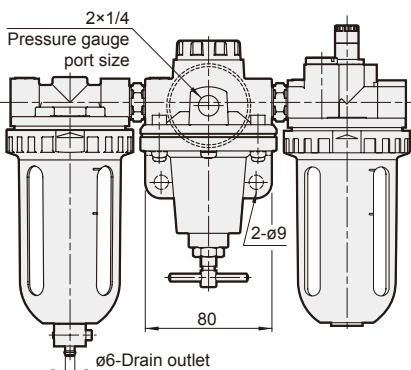
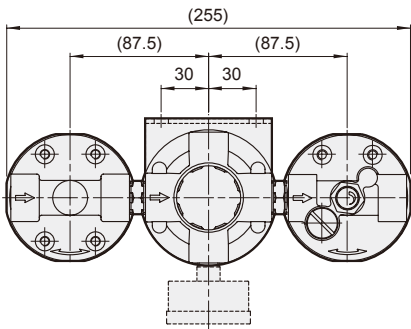

### Flow feature

