

Table for standard stroke

Tube I.D.	Stroke (mm)
ø20,25	5,10,15,20,25,30,40,50,60,80,100,200
ø32,40	5,10,15,20,25,30,40,50,60,80,100,200,300
ø50,63	10,15,20,25,30,40,50,60,80,100,200,300,400
ø80,100	15,20,25,30,40,50,60,80,100,200,300,400,500



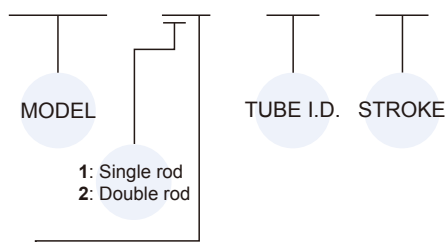

* Please consult us if stroke out of specification.

Order example

MCJI – 12 – 20 – 25



STYLE

Code	Symbol	Description
1 1		Double acting / Male thread
1 2		Double acting / Female thread
2 1		Double rod / Male thread
2 2		Double rod / Female thread

* Order example for special specification, refer to page 0-7.

Features

- ISO 21287 standard.
- Wide range of bore sizes and strokes.
- Ultra compact, light weight and space saving.
- Sensor slots on RCI sides for flush mounting of proximity sensors.
- Magnetic as standard.

Specification

Model	MCJI	
Acting type	Double acting	
Tube I.D. (mm)	20,25	32,40,50,63,80,100
Port size	M5×0.8	G1/8
Medium	Air	
Operating pressure range	0.05~1 MPa	
Proof pressure	1.5 MPa	
Cushion	Rubber bumper	
Lubricator	Without lubrication	
Stroke length tolerance (*)	+0~+1.0 mm	
Ambient temperature	-5°C~+60°C (No freezing)	
Available speed range	50~500 mm/sec	
Sensor switch	RCI (Please refer to page 8-11)	

* Stroke length tolerance does not include the amount of bumper change.

Mounting accessories

FAC – MCJI – 20

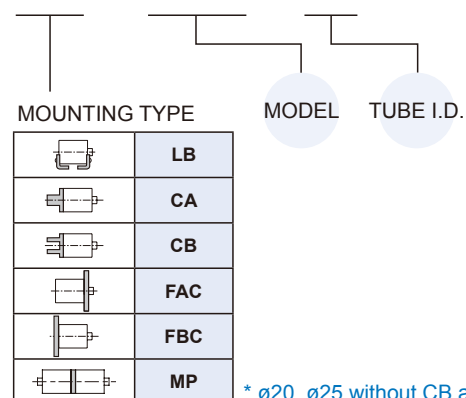

* ø20, ø25 without CB accessory.

Installation of sensor switch

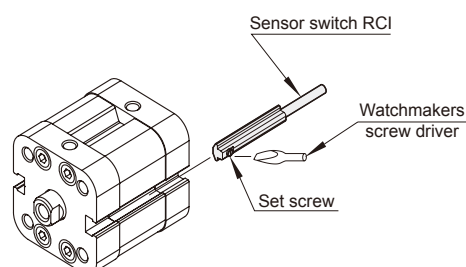

Theoretic force



Unit: N

Tube I.D.	Acting direction	Operating perssure (MPa)		
		0.3	0.5	0.7
20	IN	69	116	162
	OUT	92	154	216
25	IN	121	202	283
	OUT	144	241	337
32	IN	203	339	475
	OUT	237	394	552
40	IN	337	561	785
	OUT	370	616	863
50	IN	519	864	1210
	OUT	578	963	1348
63	IN	858	1430	2003
	OUT	917	1529	2141
80	IN	1387	2311	3236
	OUT	1479	2466	3452
100	IN	2219	3698	5178
	OUT	2311	3852	5393

Allowable Lateral Load

Please make sure to use the cylinder within allowable lateral load. Otherwise, the cylinder may be damaged or the life may be shortened.

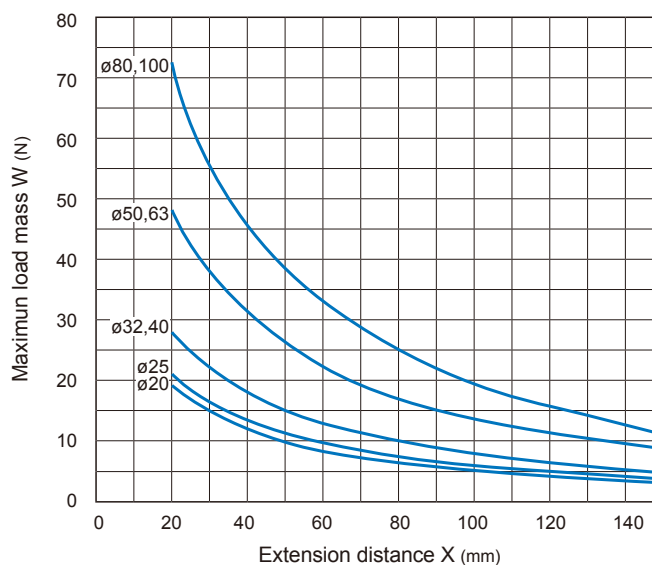
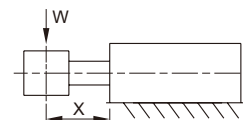

Allowable kinetic energy

Please make sure to use the cylinder within allowable kinetic energy. If it is used outside the range, it may cause excessive impact and damage the device.

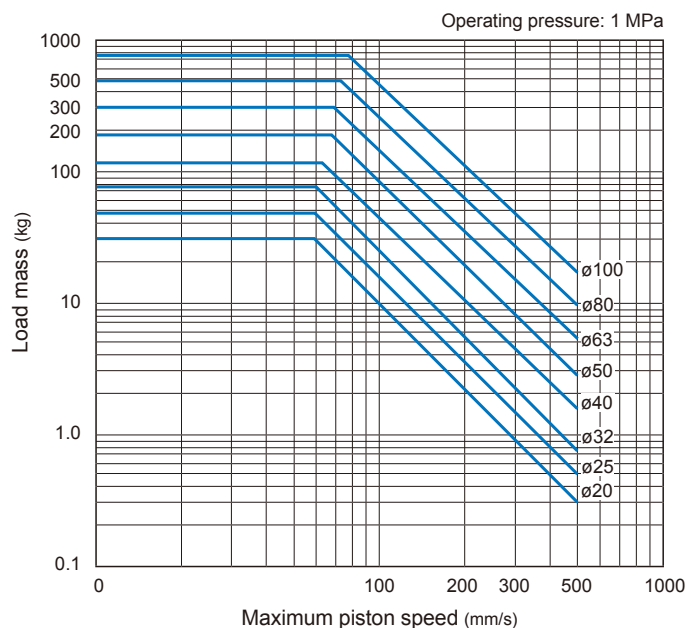

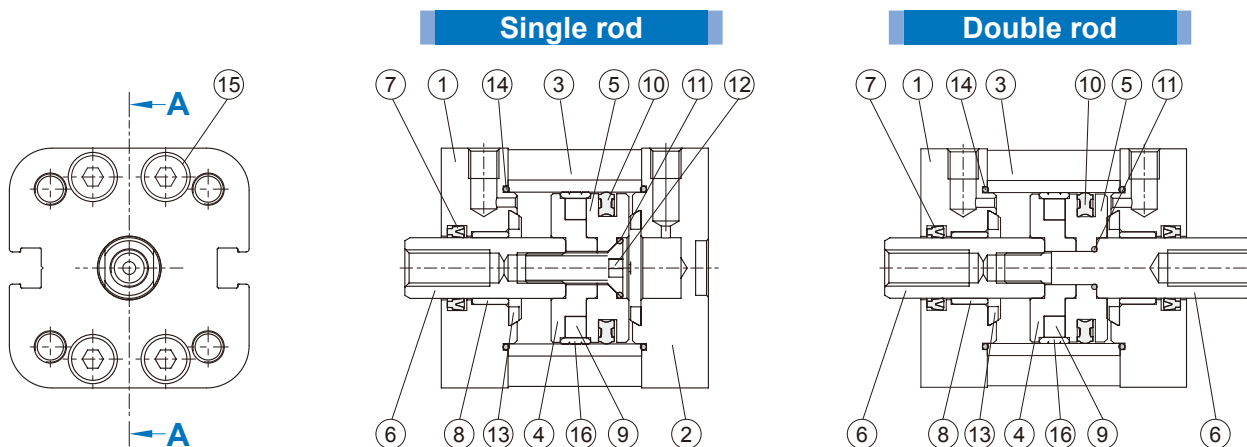

Order example Component parts / Repair kits

Material

No.	Part name	Material	Q'y		Component parts (inclusion)	Repair kits (inclusion)
			Single	Double		
1	Rod cover	Aluminum alloy	1	2	●	
2	End cover	Aluminum alloy	1	—	●	
3	Tube	Aluminum alloy	1	1		
4	Piston-R	Aluminum alloy	1	1	●	
5	Piston-H	Aluminum alloy	1	1	●	
6	Piston rod	*1	1	2		
7	Rod packing	NBR	1	1	●	●
8	Bush	Bearing alloy	1	1	●	
9	Magnet ring	Magnet material	1	1	●	
10	Piston packing	NBR	1	1	●	●
11	O-ring	NBR	1	1	●	●
12	Screw	Carbon steel	1	—	●	
13	Cushion	NBR	2	2	●	●
14	O-ring	NBR	2	2	●	●
15	Screw	Stainless steel	8	8	●	
16	Wear ring	Resin	1	1	●	

*1. Material $\phi 20, \phi 25$: Stainless steel; $\phi 32 \sim \phi 100$: Medium carbon steel.

Single rod











Tube I.D.	Component parts	Repair kits
$\phi 20$	CP-MCJI-20	PS-MCJI-20
$\phi 25$	CP-MCJI-25	PS-MCJI-25
$\phi 32$	CP-MCJI-32	PS-MCJI-32
$\phi 40$	CP-MCJI-40	PS-MCJI-40
$\phi 50$	CP-MCJI-50	PS-MCJI-50
$\phi 63$	CP-MCJI-63	PS-MCJI-63
$\phi 80$	CP-MCJI-80	PS-MCJI-80
$\phi 100$	CP-MCJI-100	PS-MCJI-100

Double rod

Tube I.D.	Component parts	Repair kits
$\phi 20$	CP-MCJI-2-20	PS-MCJI-2-20
$\phi 25$	CP-MCJI-2-25	PS-MCJI-2-25
$\phi 32$	CP-MCJI-2-32	PS-MCJI-2-32
$\phi 40$	CP-MCJI-2-40	PS-MCJI-2-40
$\phi 50$	CP-MCJI-2-50	PS-MCJI-2-50
$\phi 63$	CP-MCJI-2-63	PS-MCJI-2-63
$\phi 80$	CP-MCJI-2-80	PS-MCJI-2-80
$\phi 100$	CP-MCJI-2-100	PS-MCJI-2-100

Cylinder weight

Unit: g

Model	Basic weight MCJI-11	Stroke 10mm MCJI-11	Basic weight MCJI-12	Stroke 10mm MCJI-12	LB	FAC/FBC	MP	CA	CB	PIN (for CB)	Nut
Tube I.D.											
$\phi 20$	121	14	108	14	76	126	28	66	N/A	N/A	3
$\phi 25$	147	18	135	18	88	159	37	82	N/A	N/A	3
$\phi 32$	238	24	214	24	106	206	60	174	160	31	7
$\phi 40$	322	32	291	32	140	268	89	260	248	51	7
$\phi 50$	493	46	455	46	242	492	129	403	390	58	9
$\phi 63$	703	48	667	48	288	635	182	634	576	119	9
$\phi 80$	1260	76	1190	76	567	1457	339	1149	1085	150	18
$\phi 100$	2140	92	2060	92	766	2033	568	1550	1623	285	18

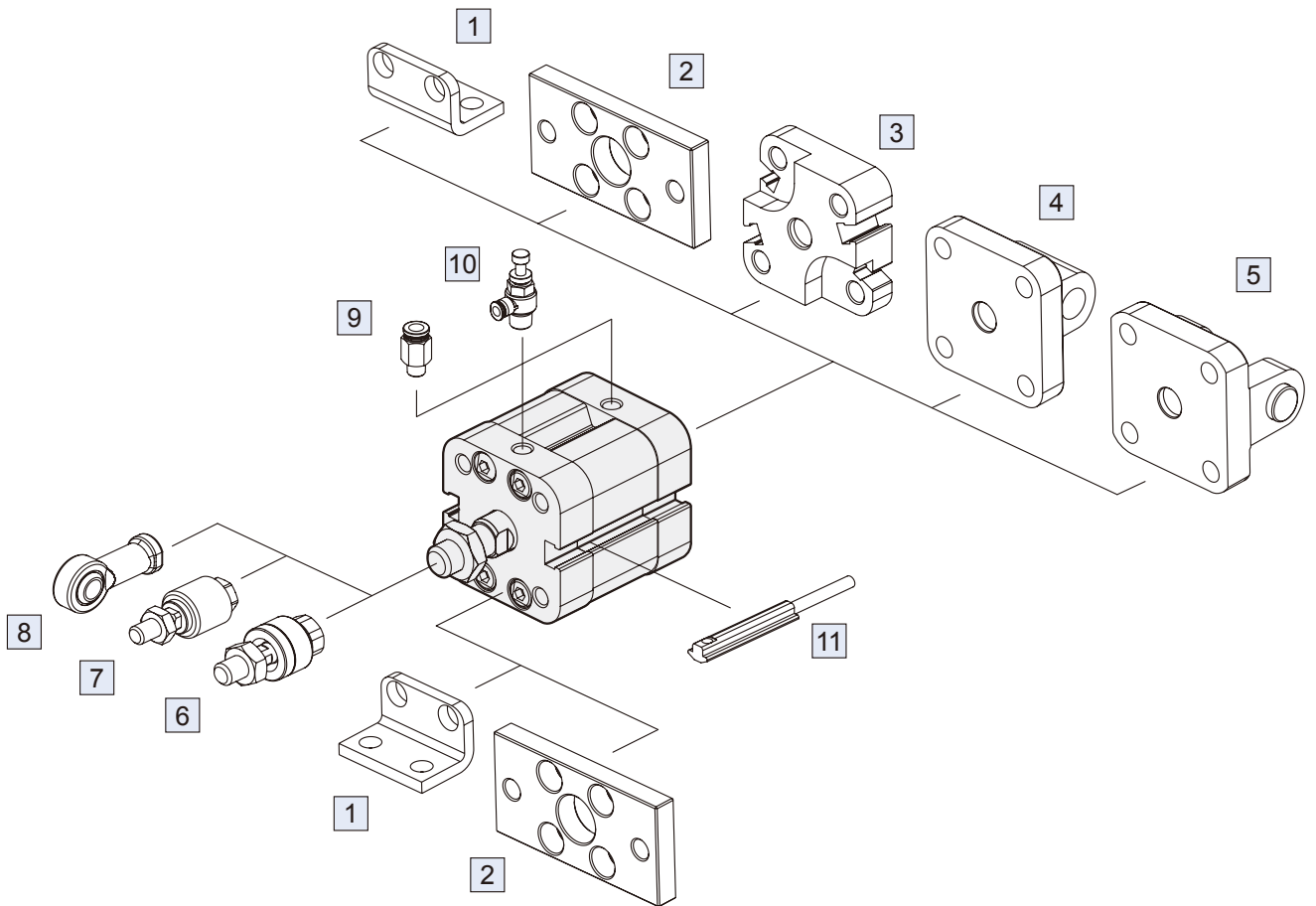

No.	Accessories	Material	Page
1	Mounting accessories LB	Carbon steel	2-56
2	Mounting accessories FAC/FBC	Carbon steel	2-57
3	Mounting accessories MP	Aluminum	2-56
4	Mounting accessories CA	Cast iron	2-58
5	Mounting accessories CB+PIN	Cast iron / *	2-58
6	Floating joint MFC	Carbon steel	8-2
7	Floating joint MFCS	Carbon steel	8-5
8	Female rod ends PHS	Carbon steel	8-6
9	Fitting PC (PISCO)	–	7-3 (Vol.1)
10	Speed controller JSC (PISCO)	–	7-15 (Vol.1)
11	Sensor switch RCI	–	8-13

* Material of PIN is carbon steel.

Single rod

Double rod

$\phi 20 \sim \phi 25$

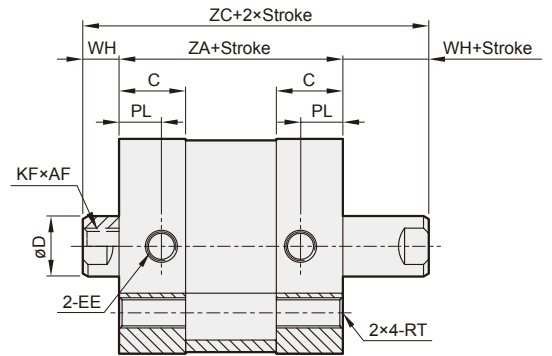
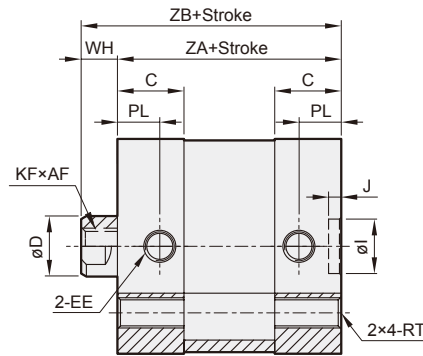
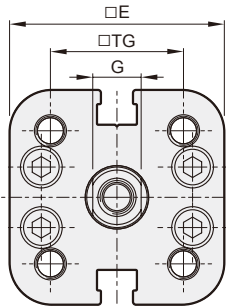

$\phi 32 \sim \phi 100$

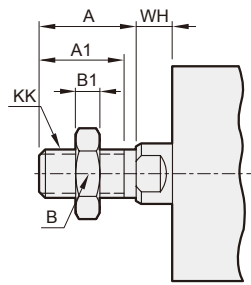
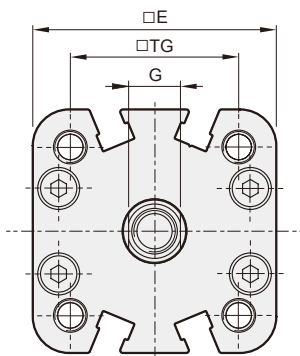

MCJI-11/21 male thread size

Code Tube I.D.	A	A1	B	B1	KK
20	16	14	13	4	M8×1.25
25	16	14	13	4	M8×1.25
32	19	17	17	5	M10×1.25
40	19	17	17	5	M10×1.25
50	22	20	19	6	M12×1.25
63	22	20	19	6	M12×1.25
80	28	26	24	8	M16×1.5
100	28	26	24	8	M16×1.5

Code Tube I.D.	AF	C	D	E	EE	G	WH	I	J	KF	PL	TG	RT	ZA	ZB	ZC
20	14	11	10	35.5	M5×0.8	8	6	9	2.1	M6×1.0	7	22	M5×0.8	37	43	49
25	14	11	10	39.5	M5×0.8	8	6	9	2.1	M6×1.0	7	26	M5×0.8	39	45	51
32	15	14	12	47.0	G1/8	10	7	9	2.1	M8×1.25	7.5	32.5	M6×1.0	44	51	58
40	15	14	12	54.5	G1/8	10	7	9	2.1	M8×1.25	7.5	38	M6×1.0	45	52	59
50	18	14	16	65.5	G1/8	14	8	12	2.6	M10×1.5	7.5	46.5	M8×1.25	45	53	61
63	18	14.5	16	75.5	G1/8	14	8	12	2.6	M10×1.5	7.5	56.5	M8×1.25	49	57	65
80	20	15.5	20	95.5	G1/8	17	10	12	2.6	M12×1.75	8	72	M10×1.5	54	64	74
100	20	18.5	20	113.5	G1/8	17	10	12	2.6	M12×1.75	9.5	89	M10×1.5	67	77	87

MP

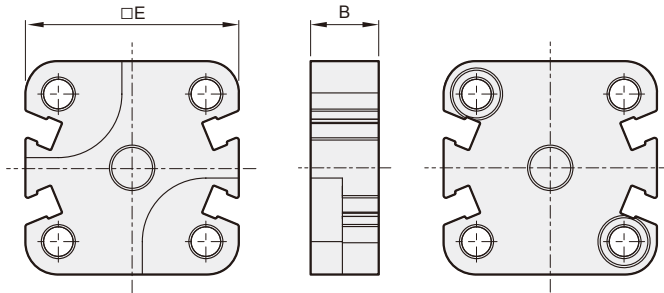

Code Tube I.D.	B	E	WH	ZA	Max. overall stroke
20	13	35.5	6	37	600 mm
25	13	39.5	6	39	600 mm
32	15	47.0	7	44	800 mm
40	15	54.5	7	45	800 mm
50	15	65.5	8	45	800 mm
63	15	75.5	8	49	800 mm
80	17	95.5	10	54	1000 mm
100	19.5	113.5	10	67	1000 mm

* The max. overall stroke length may not be exceeded when combining cylinders and multi-position kits.

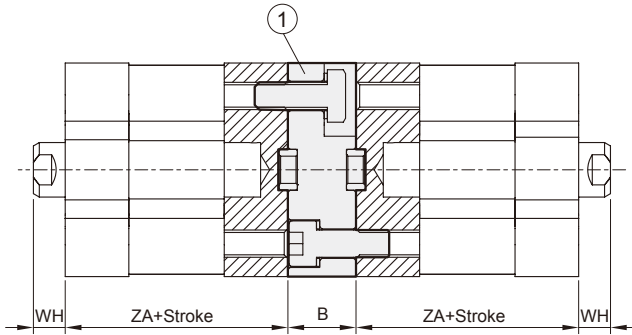

No.	Part name	Q'y
1	Connection block	1
2	Flange	2
3	Bolt	2
4	Bolt	2

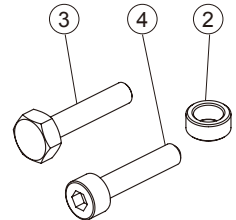

LB

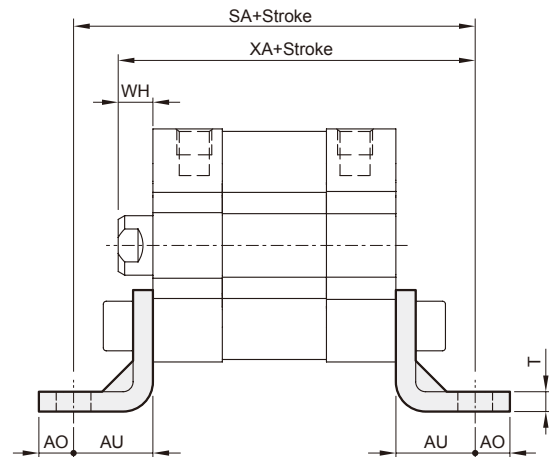
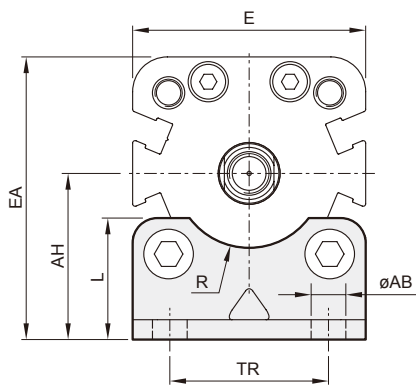

Code Tube I.D.	AB	AH	AO	AU	E	EA	L	R	SA	T	TR	WH	XA
20	7	27	7	16	35.5	44.8	21	—	69	4	22	6	59
25	7	29	7	16	39.5	48.8	22	—	71	4	26	6	61
32	7	33.5	7	16	47.0	57.0	24.5	15	76	4	32	7	67
40	10	38	9	18	54.5	65.3	26	17.5	81	4	36	7	70
50	10	45	9	21	65.5	77.8	31	20	87	5	45	8	74
63	10	50	9	21	75.5	87.8	31	22.5	91	5	50	8	78
80	12	63	11	26	95.5	110.8	40	—	106	6	63	10	90
100	14.5	74	13	27	113.5	130.8	46	—	121	6	75	10	104

FAC

$\varnothing 20 \sim \varnothing 25$

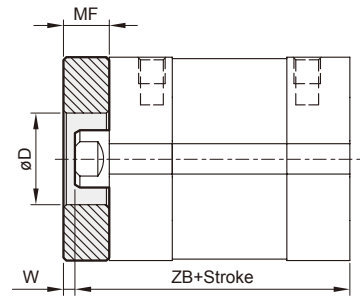
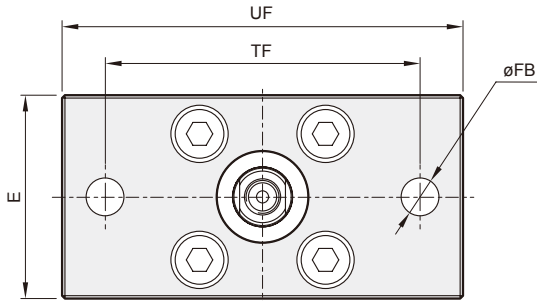

$\varnothing 32 \sim \varnothing 100$

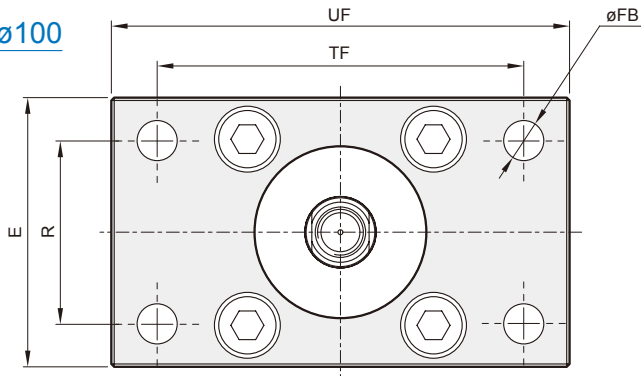

Code Tube I.D.	D	E	FB	MF	R	TF	UF	W	ZB
20	16	35.5	6.6	8	—	55	70	2	43
25	16	39.5	6.6	8	—	60	76	2	45
32	30	47.0	7	10	32	64	80	3	51
40	35	54.5	9	10	36	72	90	3	52
50	40	65.5	9	12	45	90	110	4	53
63	45	75.5	9	12	50	100	120	4	57
80	45	95.5	12	16	63	126	150	6	64
100	55	113.5	14	16	75	150	175	6	77

FBC

$\varnothing 20 \sim \varnothing 25$

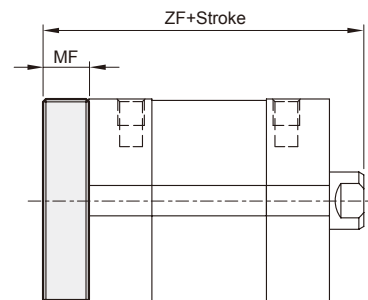
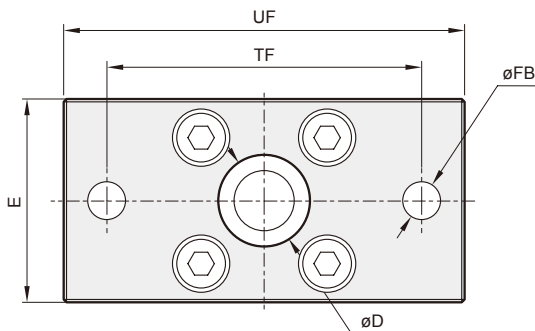

$\varnothing 32 \sim \varnothing 100$

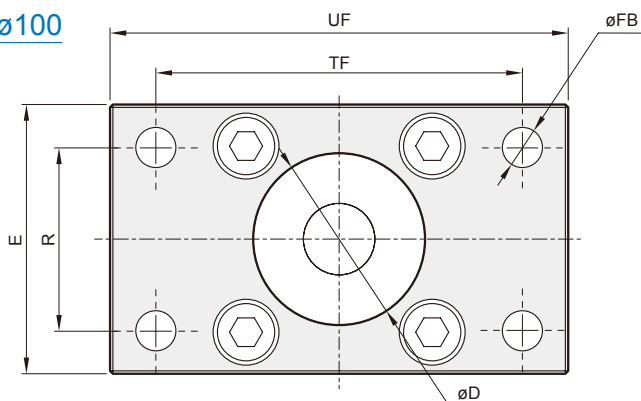

Code Tube I.D.	D	E	FB	MF	R	TF	UF	ZF
20	16	35.5	6.6	8	—	55	70	51
25	16	39.5	6.6	8	—	60	76	53
32	30	47.0	7	10	32	64	80	61
40	35	54.5	9	10	36	72	90	62
50	40	65.5	9	12	45	90	110	65
63	45	75.5	9	12	50	100	120	69
80	45	95.5	12	16	63	126	150	80
100	55	113.5	14	16	75	150	175	93

CA

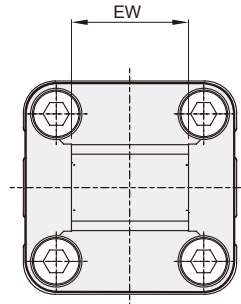
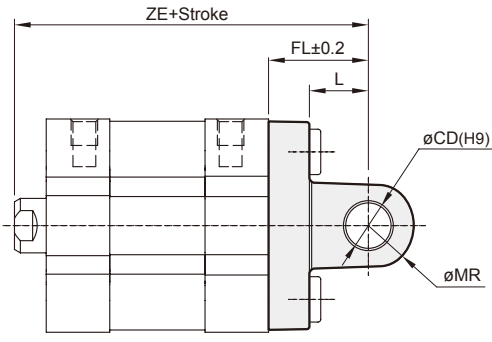

Code Tube I.D.	CD	EW	FL	L	MR	ZE
20	8	16 h12	20	14	8	63
25	8	16 h12	20	14	8	65
32	10	25.8 ⁺⁰ _{-0.4}	22	13	10	73
40	12	27.8 ⁺⁰ _{-0.4}	25	16	12	77
50	12	31.8 ⁺⁰ _{-0.4}	27	16	12	80
63	16	39.8 ⁺⁰ _{-0.4}	32	21	16	89
80	16	49.8 ⁺⁰ _{-0.4}	36	22	16	100
100	20	59.8 ⁺⁰ _{-0.4}	41	30	21	118

CB

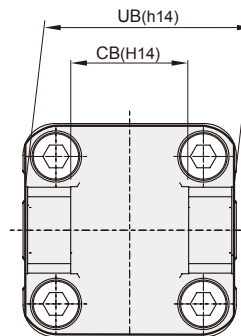
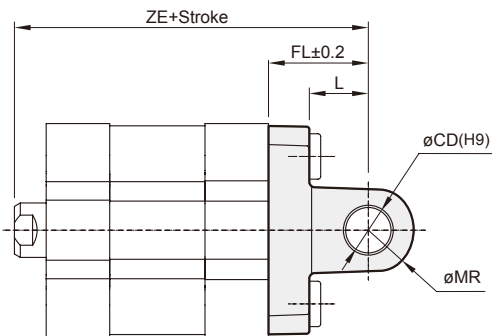

Code Tube I.D.	CB	CD	FL	L	MR	UB	ZE
32	26	10	22	13	10	45	73
40	28	12	25	16	12	52	77
50	32	12	27	16	12	60	80
63	40	16	32	21	16	70	89
80	50	16	36	22	16	90	100
100	60	20	41	29	20	110	118

* $\varnothing 20$, $\varnothing 25$ without CB accessory.

PIN

Order example

PIN — MCJI — 32 — CB — P

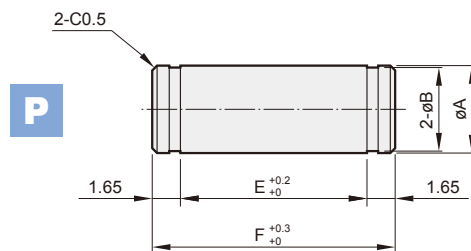
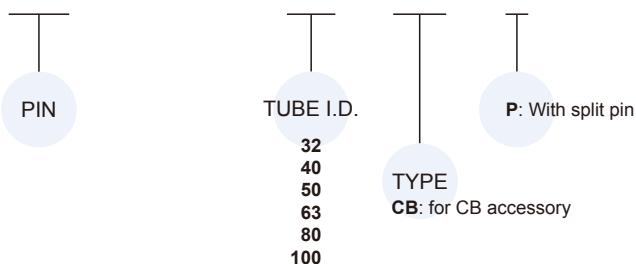

Code Tube I.D.	A(e8)	B	C	E	F	Snap ring
32	10	9.6	2.65	45.2	50.5	STW-10
40	12	11.5	2.65	52.2	57.5	STW-12
50	12	11.5	2.65	60.2	65.5	STW-12
63	16	15.2	2.65	70.2	75.5	STW-16
80	16	15.2	2.65	90.2	95.5	STW-16
100	20	19	2.85	110.3	116	STW-20